

PRESSURE IN. W.G.

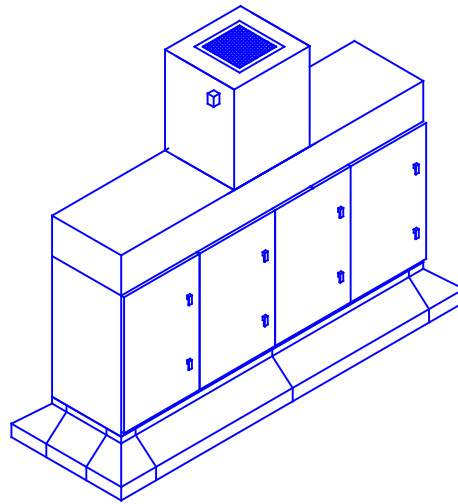

CFM X's 100



SHEET TITLE : AZTech RH36V-1X4

DRWG. NO. RH36V145-0311

DRAWN BY: TAA

DATE: 05/14/18

SCALE: NTS

SPECIFICATIONS:

DIMENSIONS: 96"H X 118" W X 38" D

MOTOR: 5 HP 230/460/3/60 TEFC, 12.4/6.2 FLA

CFM: 4500 CFM @ 3.0" W.G.

ELECTRICAL WIRED TO JCT. BOX

BLOWER: DIRECT DRIVE BI WHEEL

CONSTRUCTION 12 & 14 GA POWDER COATED STEEL FRAME. (20 16 GA STEEL DOORS. 3/16 POLYETHYLENE PANELS. ADJ. COMPRESSION HINGES AVAILABLE. 11 & 18 GA HOOD CAM DOOR AND FILTER LATCHES DUST PROOF LIGHT KIT

STD. FILTERS: (4) 2" BAFFLES (4) 4" PLEATED FILTERS (4) 95% BAG FILTERS, 108 SF EA.

OPTIONAL FILTERS: (4) 2" MIST ELIMINATORS (8) 26 LB CARBON MODULES (4) 2" ALUMINUM MESH (4) 2" POLY PADS (4) 4" MIST ELIMINATORS (4) 99.97% HEPA AFTERFILTERS

OPTIONS: ACOUSTIC LINING MAGNAHELIC PRESSURE GAUGE FLOOR STAND EYEBOLTS CUSTOM HOOD SIZES THERMAL SENSOR/ POWER CUT OFF

WEIGHT: 1490 LBS.

NOISE: 83.0 dBA

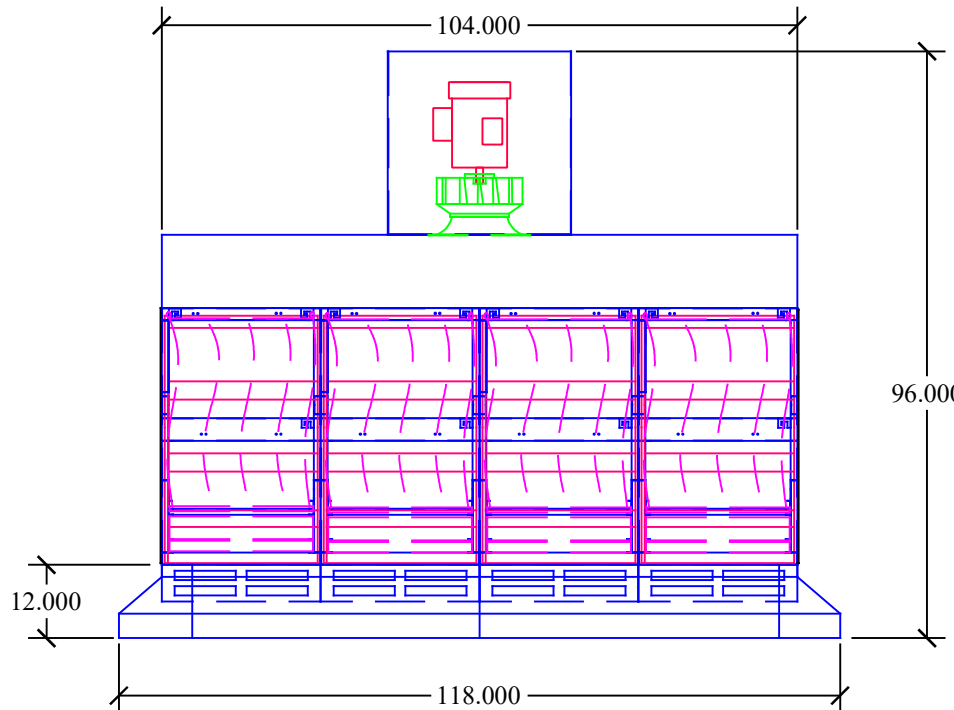
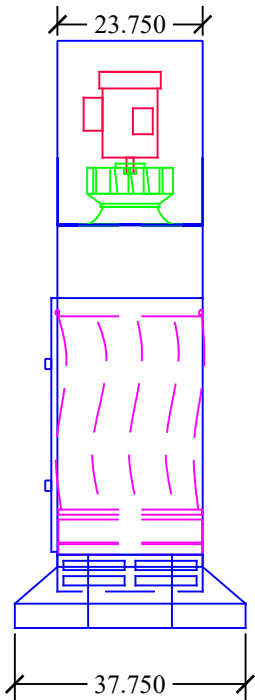

DISTRIBUTED BY:

COPYRIGHT: This document and the information contained may not be reproduced or distributed without express written consent of INDUSTRIAL MAID. Unauthorized reproduction, disclosure, or manufacturing use are prohibited by copyright law.



INDUSTRIAL MAID

MFG. BY:

INDUSTRIAL MAID LLC
351 S. 12TH RD.

CORTLAND, NE 68331

Ph. (402) 798-7116

Fax (402) 798-7117

www.industrial-maid.com