



Owners Manual

AZTech Model T3500/T4500 INDUSTRIAL AIR CLEANER



Contents

Safety/Inspection	2
Specifications.....	3
Installation.....	4
Replacement Parts	6
Electrical	7
Troubleshooting/Notes	13
Warranty	18

SAFETY

PLEASE READ THE FOLLOWING INSTRUCTIONS CAREFULLY BEFORE INSTALLING, OPERATING OR SERVICING YOUR AIR CLEANER.

Follow all building and safety codes when installing this equipment. Pertaining but not limited to, the Occupational Safety and Health Act (OSHA), National Electric Code (NEC), Uniform Building Code (UBC), National Fire Prevention Act (NFPA) & all state and local codes.

A qualified electrician should perform all electrical connections.

Keep Flammable Objects away from the air cleaner and under no condition should a burning object be allowed into the air cleaning system.

Take proper caution in placing units in buildings with radiant heaters installed. Follow the radiant heater manufacturer's guidelines for clearance to combustibles.

Do not mix materials collected in your Air Cleaner. The captured materials could create a hazardous environment or a condition of operation for which the equipment is not intended. The Manufacturer is relieved of any liability if the unit is not operated according to this manual.

Do not use the Air Cleaner for an application other than for which it was intended. Consult your distributor, Applicable Codes, or call Industrial Maid for application assistance.

A fire suppression system is not included. Please consult your local fire protection specialist for any required extinguishing equipment.

Consult with your insurance underwriter about any other protection from fire damages.

The Manufacturer reserves the right to make design changes, which may improve the air cleaner.

This unit is intended for use to collect ambient smoke, airborne pollutants, and fumes in industrial and manufacturing facilities. Do not use for the collection of flammable or explosive metals, dust, fumes, or other potentially hazardous materials.

INSPECTION

Upon receiving your Industrial Maid air cleaner, please inspect for any damage incurred during shipment. Inspect carefully; some damage may not be noticeable until the unit is installed. Notify your shipper of any damage immediately. Claims must be filed with the shipper within 15 days. Freight damage claims are the responsibility of the purchaser.

SPECIFICATIONS

Cabinet	14 ga powder coated steel frame. 3/16 polyethylene panels(14 ga steel panels, optional)	
Size	25”H x 72”L x 25”D (single cabinet)	
Weight	T3500 - 192 lbs. T4500 - 199 lbs.	
Power	T3500 208-230/460/3/60	6.0/3.0amps
	T4500 208-230/460/3/60	7.6/3.8 amps
Air Volume	T3500 - 3,500 CFM T4500 - 4,500 CFM	
Motor	T3500 - 2 HP 208-230/460/3/60 TEFC T4500 - 3 HP 208-230/460/3/60 TEFC	
Blower	10 x 10 Belt Drive Forward Curve	
Exhaust	Four Way adjustable louver	
Filters	Prefilter - (2) 4” Pleats Main Filter – (2) 24 x 24 x 21, 95%, 10 Pocket Fiberglass Bags	
Warranty	3 year limited warranty	

INSTALLATION

The system's weight must be taken into account when choosing the proper installation method (see specification). Follow all applicable building and electrical codes.

There are three main ways of installing your Model 3500 air cleaner, Chain Hanging (eye bolts factory installed as option), rod & cradle, or angle braces. Figure 2 illustrates these methods. Do not chain mount double cabinet units, use (4) 5/8" threaded rod and cradle the collector (lower right, figure 2).

Figure 1.

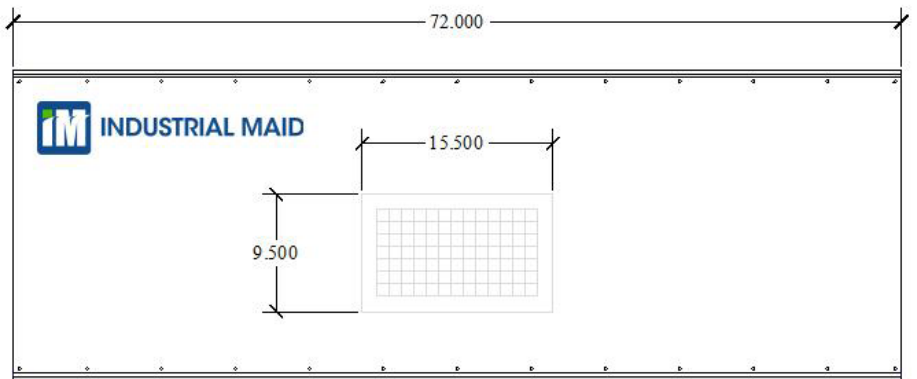
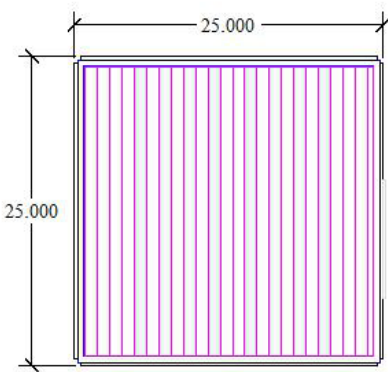

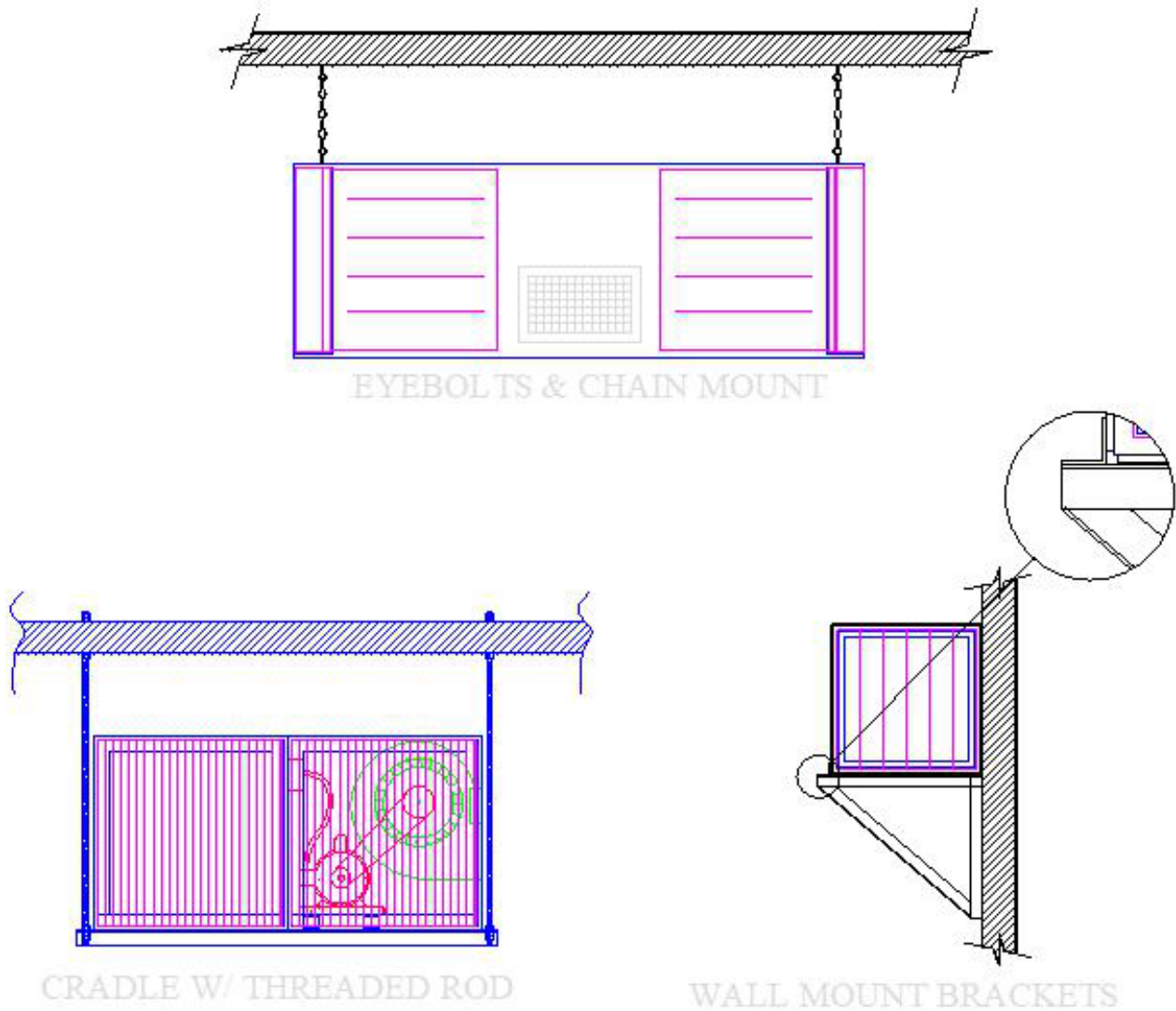

Figure 2.

Mounting materials must be able to support the weight of the air cleaner plus the additional weight of the material collected. Consult your local building code for proper installation methods and materials. Failure to use the proper materials could result in injury or damage equipment and will void the warranty.

REPLACEMENT PARTS

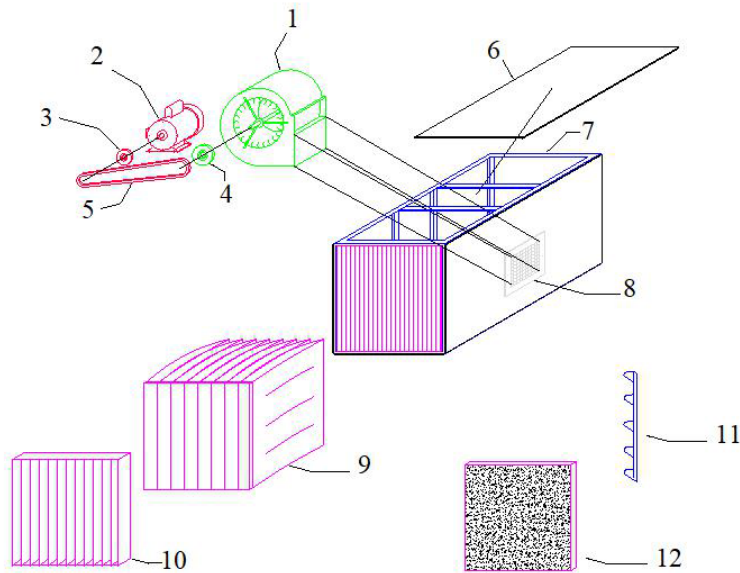

Figure 4

ITEM	PART NUMBER	QTY	DESCRIPTION
1	BW10-AA10	1	2 & 3 HP BLOWER ASSEMBLY
2A	MT02-2431-SG	1	T3500, 2 HP 230/460/3/60 TEFC MOTOR
2B	MT03-2433-SG	1	T4500, 3 HP 230/460/3/60 TEFC MOTOR
3	PT78-0035	1	2 & 3 HP DRIVE PULLEY
4A	PT34-0005	1	2 HP BLOWER PULLEY, 5" FIXED
4B	PT34-0010	1	3 HP BLOWER PULLEY, 10" FIXED
5A	PT0A-0040	1	2 HP - A40 DRIVE BELT
5B	PT0A-0049	1	3 HP - A49 DRIVE BELT
6A	003500-11PE	3,5 or 7	3/16 POLYETHYLENE PANELS, TOP, BOTTOM, & BACK
6B	003500-10PE	1	3/16 POLYETHYLENE PANEL, EXHAUST
7	FR35-ASSY	1	14 GA FRAME ASSEMBLY
8	GR07-0013	1	4-WAY ADJUSTABLE EXHAUST GRILLE
9A	FB91-2424	2,4,6 or 8	95 % FIBERGLASS BAG FILTER
9B	FB61-2424	2,4,6 or 8	65 % FIBERGLASS BAG FILTER
10	FP44-2424	2,4,6 or 8	4" PLEATED PREFILTER
11	FD02-2727	2	2" POLY PAD PREFILTER - OPTIONAL
12	253560-PFHK	2	POLY PAD PREFILTER MOUNTING HOOK - OPTIONAL

ELECTRICAL WIRING

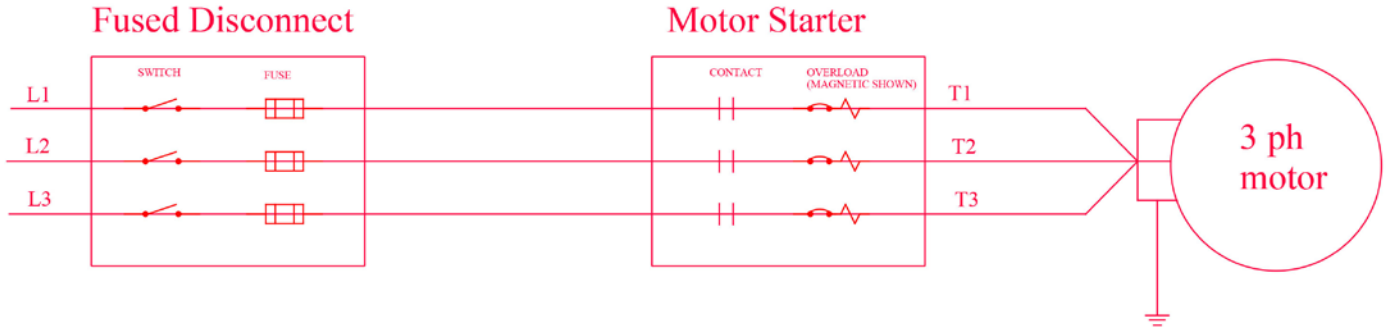

FIGURE 4. TYPICAL WIRING DIAGRAM

Unit comes wired to a junction box. Additional wiring will be required to get power to unit, which is not supplied with this product.

Motor Starters, disconnect, wiring, overloads, and thermal protection are NOT provided by the Manufacturer.

All Field wiring should be performed by a qualified electrician and must meet all local, NFPA and NEC codes. Failure to install the proper electrical wiring, thermal protection, and controls will void the warranty.

After completion of the field wiring, turn the unit on to check for proper rotation. Rotation is marked on the side of the blower housing. Backward rotation will result in a much lower air flow, louder noise, and will over amp the motor. Check the motor nameplate before switching wires and reversing rotation, to ensure the unit is operating at or below rated amp draw.

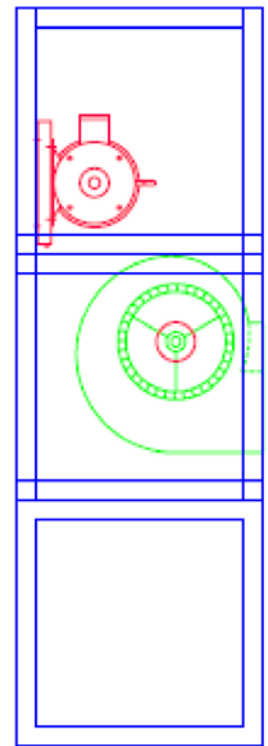
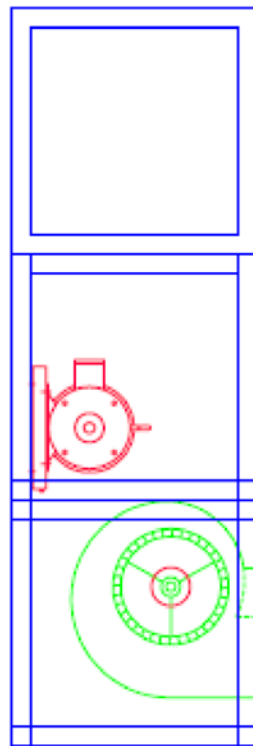
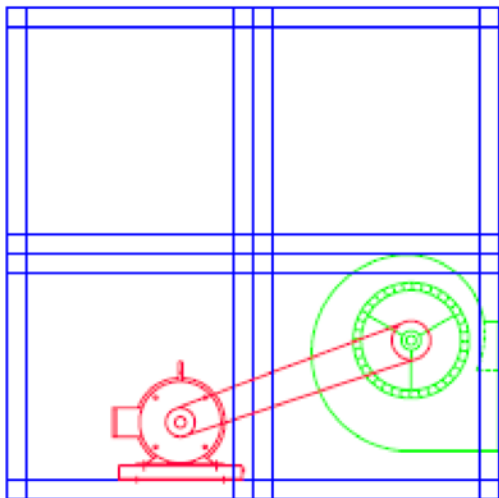
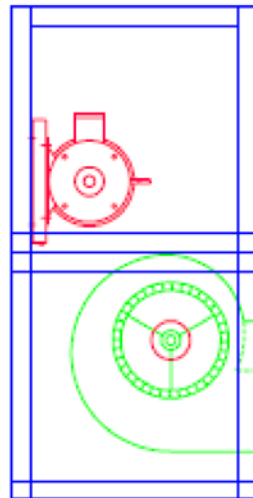
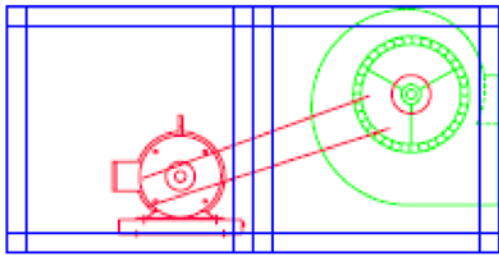

ARRANGEMENT OPTIONS

MOTOR MOUNTING

Motor must be securely fastened to a rigid, flat surface to prevent vibration and minimize noise. For secure mounting use high-quality bolts of the largest possible diameter.

Belt-drive sheaves must be in-line. Use a straight edge to check. Do not over-tighten belts.

Direct coupled installations require a careful check of shaft and coupling alignment, shaft offset and/or angular misalignment should be less than .002". Shim motor base as necessary. Do not depend on a flexible coupling to compensate for misalignment.

Table A - Minimum Wire Sizes for 3- Phase Motors

Motor HP	25 to 50 Feet			100 Feet			150 to 200 Feet		
	200V	230V	460V	200V	230V	460V	200V	230V	460V
1/3	14	14(16)*	14(18)*	12	12	14(18)*	8	10	14(18)*
1/2	14	14(16)*	14(18)*	12	12	14(18)*	8	10	14(18)*
3/4	14	14(16)*	14(18)*	12	12	14(18)*	8	10	14(18)*
1	14	14(16)*	14(18)*	12	12	14(18)*	8	10	14(16)*
1 1/2	12	14	14(18)*	10	10	14(16)*	6	8	14
2	12	12	14(18)*	8	10	14(16)*	6	6	12
3	10	12	14(18)*	6	8	14	4	6	12
5	8	10	14(16)*	4	6	12	2	4	10
7 1/2	6	8	14	4	4	10	1	2	8
10	6	6	12	3	4	10	1/0	1	6
15	4	4	10	1	2	8	3/0	2/0	4
20	3	4	10	1/0	1	6	4/0	3/0	4
25	2	3	8	2/0	1/0	6	250kcmil	4/0	3
30	1	3	8	3/0	1/0	6	300kcmil	4/0	3
40	1/0	1	8	4/0	3/0	4	400kcmil	300kcmil	1
50	2/0	1	6	250kcmil	3/0	3	500kcmil	350kcmil	1
60	3/0	1/0	6	300kcmil	4/0	3	600kcmil	400kcmil	1/0
75	4/0	2/0	4	350kcmil	250kcmil	2	700kcmil	500kcmil	2/0
100	250kcmil	3/0	4	500kcmil	350kcmil	1	900kcmil	700kcmil	3/0
125	300kcmil	4/0	3	600kcmil	400kcmil	1/0	1250kcmil	800kcmil	4/0
150	350kcmil	250kcmil	2	700kcmil	500kcmil	2/0	1500kcmil	900kcmil	250kcmil
200	500kcmil	350kcmil	1/0	1250kcmil	800kcmil	4/0	1750kcmil	1250kcmil	350kcmil
250	600kcmil	400kcmil	2/0	1500kcmil	900kcmil	250kcmil	2000kcmil	1500kcmil	400kcmil

NOTE: kcmil denotes thousand circular mils. AWG sizes formerly given in MCM.

(*) Type S, SO, SJ, SJO, etc. flexible cable wire sizes. See NEC article 400 for ampacity.

CONNECTING POWER TO MOTOR

To connect motor for proper voltage and rotation, refer to the connection diagram on the nameplate or inside the terminal/conduit box.

Table B - Minimum Wire Sizes for Single Phase Motors

Motor HP	25 Feet		50 Feet		100 Feet		150 Feet		200 Feet	
	115V	230V	115V	230V	115V	230V	115V	230V	115V	230V
1	10	14(16)*	6	12	4	10	2	8	1	6
1 1/2	8	14	6	12	3	8	1	6	1/0	6
2	8	14	4	10	2	8	1/0	6	2/0	4
3	6	12	3	8	1/0	6	2/0	4	4/0	3
5	-	10	-	6	-	4	-	2	-	1
7 1/2	-	8	-	6	-	3	-	1	-	1/0
10	-	8	-	4	-	2	-	1/0	-	2/0

* Type S, SO, SJ, SJO, etc. Flexible cable wire sizes. See NEC Article 400 for ampacity.

NOTE: NEC Article 310-5 --- Minimum conductor size for general wiring at 115-440VAC is No. 14AWG. Above wire sizes based on approximate 5% voltage drop during starting; copper conductors; and 75° C type THHW, THW, THWN, RH, RHW insulation, etc. For aluminum wire, increase two wire size steps minimum. See NEC Article 310 for ampacities of aluminum conductors.



WARNING

All aspects of the installation must conform to the requirements of the NEC, including Article 430 (Motor circuits and Controllers), and all local codes.

Wherever possible, each motor should be powered from a separate circuit of adequate capacity to keep voltage drop to a minimum during starting and running. Increase wire size where motor is located a distance from the power source. Wire size must be adequate to minimize voltage drop during starting and running. Refer to Tables A and B for suggested wire sizes. Distances shown are one-way between source and motor. Portable cords, if used, should be as short as possible to minimize voltage drop. Long or inadequately sized cords, especially on hard starting loads, can cause motor failure. All electrical connections in system must be secure to prevent voltage drop and localized heating.

- Determine direction of rotation before connecting driven equipment to prevent damage.
- To prevent bearing damage, do not strike shafts with hammer or other tool.
- If the motor has been damp or wet, then have motor serviced by a qualified motor repair shop before operating.

Recommended Maintenance

Remove dirt accumulations in and around vent openings, by vacuuming. **Dirt accumulations can cause motor overheating and a fire hazard.** Enclosed motors can be cleaned with an air jet; wear eye protection.

Periodically inspect the installation. Check for dirt accumulations; unusual noises or vibration; overheating; worn or loose couplings, sheaves and belts; high motor current; poor wiring or overheated connections; loose mounting bolts or guards; and worn motor starter contacts.

Dayton ball-bearing motors without lubrication provision do not require periodic relubrication. Where motor has provision for bearing lubrication, lubricate as follows:

1. After stopping motor and disconnection power, thoroughly wipe the housing around both of the motor bearings, filler and drain plugs (on TEFC) ratings, remove fan cover for access to plugs).
2. Remove filler and drain plugs and install a 1/8" pipe thread lube fitting in filler hole.
3. Using a low pressure grease gun, pump new grease into motor until it appears at the drain hole.
4. Run motor for several minutes to discharge excess grease. Shut motor OFF, replace filler and drain plugs, and reinstall fan cover.

See Table C for suggested regreasing intervals.

Table C – Suggested Regreasing Intervals

TYPE OF SERVICE	MOTOR HP AT 1800 RPM MAX		
	UNDER 50	50 TO 100	OVER 100
Infrequent operation or light duty in clean atmosphere	2 Years	2 Years	1 Year
8 to 16 hours per day in clean, relatively dry atmosphere	2 Years	1 ½ Years	1 Year
12 to 24 hours per day heavy duty use, or if moisture is present	1 Year	1 Year	6 months
Heavy duty use in dirty, dusty locations; high ambients; moisture laden atmosphere; constant vibration	4 Months	4 Months	3 Months

NOTE 1: Motors operating faster than 1800 RPM should be relubricated on a more frequent maintenance schedule. Use a reputable brand lithium or synthetic-base grease intended for electric motor ball bearings. Recommended greases include: Standard Oil of California (Chevron) SRI#2, and Exxon Corp. PolyRex-EM. Keep grease container clean and covered.

MOTOR TROUBLESHOOTING

This chart suggests common answers to electric motor problems. The information is not all-inclusive and does not necessarily apply in all cases. When unusual operating conditions, repetitive failures, or other problems occur, consult an electric motor service firm.

Symptom	Possible Cause(s)	Corrective Action
Motor fails to start	1. Blown fuses	1. Replace with time-delay fuses. Check for grounded winding
	2. Voltage too low at motor terminals due to line drop	2. Consult local power company. Increase wire size (refer to Tables A & B). Check for poor connections
	3. Overload in motor starter tripped	3. Check and reset overload relay in starter. Check heater rating against motor nameplate current rating
	4. Overload (internal thermal protector) tripped	4. Check motor load. If motor has an automatic or manual reset thermal protector, check if tripped
	5. Improper line connections	5. Check connections against diagram supplied with motor
	6. Motor may be overloaded	6. Reduce load or increase motor size
Motor does not come up to speed or takes too long to accelerate	1. Not applied properly	1. Consult motor service firm for proper type. Use larger motor
	2. Voltage too low at motor terminals	2. Increase wire size (refer to Tables A & B). Check for poor connections. Check for voltage unbalance (3-Phase)
	3. Starting load too high	3. Check load motor is carrying at the start
	4. Excess loading; tight belts	4. Reduce load; increase motor size. Adjust belts

Symptom	Possible Cause(s)	Corrective Action
	5. Defective motor.	5. Replace or repair
	6. Inadequate starting torque. High inertia load	6. Replace with a larger motor
Motor stalls during operation	1. Overloaded motor	1. Reduce load or increase the motor size
	2. Low motor voltage	2. Verify that nameplate voltage is maintained
Motor vibrates or is excessively noisy	1. Motor shaft is misaligned	1. Realign
	2. 3-phase motor running on single phase	2. Check for open circuit, blown fuses or unbalanced voltages
	3. High or unbalanced voltages	3. Check wiring connections. Consult local power company
	4. Worn, damaged, dirty or overloaded bearings	4. Replace bearings; check loading and alignment
	5. Defective winding. Bent or bowed shaft	5. Repair or replace
	6. Loose sheave or misaligned coupling	6. Tighten set screw(s); realign coupling
Motor overheats while running under load	1. Overloaded	1. Reduce load; increase motor size; belts may be too tight
	2. Dirt blocking ventilation openings	2. Clean motor
	3. If 3-Phase, one phase may be open	3. Check lines for open phase. Check voltage with motor disconnected, one fuse may be blown.
	4. Unbalanced supply voltage	4. Check for faulty connections. Voltage on all three lines should be balanced within 1%. Balance single phase loads.
	5. Faulty connection	5. Clean, tighten, or replace
	6. High or low voltage	6. Check voltage at motor, should not be more than 10% above or below rated
	7. Defective motor	7. Repair or replace

BLOWER OPERATION

After electrical connections are completed, start motor briefly to determine the direction of wheel rotation. If necessary to reverse the rotation, follow instructions given on the motor nameplate or terminal box cover.

With air system in full operation, and with all ducts attached and inspection door(s) closed, measure the current input to the motor and compare with nameplate rating to determine if the motor is operating under safe load conditions.

Blower Maintenance

1. After electrical connections are completed, start motor briefly to determine the direction of wheel rotation. If necessary to reverse. The rotation, follow instructions given on the motor nameplate or terminal box cover.
2. Follow motor manufacturer's instructions for motor lubrication. Remove excess lubricant.
3. Follow Replacement Parts Manual for blower bearing lubrication.
4. Check wiring to make sure it is secure and well insulated

BLOWER TROUBLESHOOTING CHART

Symptom	Possible Cause(s)	Corrective Action
Excessive noise and/or vibration	1. Foreign object	1. Remove
	2. Wheel rubbing on housing	2. Center the wheel
	3. Loose wheel or sheave on shaft	3. Tighten all set screws
	4. Motor or blower not secure	4. Tighten Mounting
	5. Belt(s) too loose/too tight	5. Adjust Tension
	6. Worn belt(s)	6. Replace
	7. Mismatched belt(s)	7. Replace
	8. Loose or worn bearings	8. Replace
	9. Bearing or drive alignment	9. Realign
	10. Accumulation of material on wheel	10. Clean
	11. Motor out of balance	11. Replace
	12. Wheel out of balance	12. Replace or Re-balance
	13. Sheaves eccentric or out of balance	13. Replace

Symptom	Possible Cause(s)	Corrective Action
Insufficient air flow	1. Blower speed too low	1. Check for correct drives
	2. Dampers or registers closed	2. Open
	3. Dirty or clogged filters	3. Clean or replace
	4. Leaks in duct work	4. Repair
	5. Elbows, cabinet walls, or other obstructions	5. Correct
	6. Belt slippage	6. Adjust or replace
Too much air flow	1. Blower speed too high	1. Check for correct drives
	2. Filter(s) not in place	2. Install filter(s)
Unit fails to operate	1. Blown fuse or open circuit breaker	1. Replace fuse or reset circuit breaker
	2. Broken fan belt	2. Replace
	3. Defective motor and/or capacitor	3. Replace
Motor overloads or overheats	1. Blower speed too high or motor horsepower too low	1. See Specifications for correct drives and HP
	2. System static pressure too low	2. Check static pressure and correct syst
	3. Shorted windings in motor	3. Replace

WARRANTY

1. **Limited Product Warranty.** Industrial Maid, LLC, 351 S. 12th Rd., Cortland, NE, 68331, hereby warrants to any owner who has purchased the equipment other than for purposes of resale, as follows:
 - A. All components of air cleaners and air filtration equipment manufactured (collectively “Components”) by Industrial Maid, as well as motors and drives installed on Industrial Maid units (collectively “Components”) will be manufactured in conformity with stated materials, dimensions, and tolerances;
 - B. Components manufactured by Industrial Maid, as well as motors and drives installed in Industrial Maid units, will, in normal use and service, be free from defects in material and workmanship for a period of thirty-six (36) months;
 - C. Components not manufactured by Industrial Maid (other than motors and drives) are not included within the thirty-six (36) month Warranty. These excluded items include HMI Control Panels, motor starters, disconnects, filters, duct work, and installation not supplied by Industrial Maid. The Limited Product Warranty on these items, when sold by Industrial Maid as part of the unit, is twelve (12) months and parts only.
 - D. Upon delivery, Industrial Maid will convey good and marketable title to the Components to Owner free and clear of all liens and encumbrances other than those arising in favor of Industrial Maid, including the purchase money security interest.
2. **Duration of Warranty/Notice Requirements.** The warranties set forth in Section 1 above shall apply to covered defects in Components that are discovered by Owner within the respective thirty-six (36) months or twelve (12) months following the Invoice Date (the “Warranty Period”) and are reported to Industrial Maid in writing within thirty (30) calendar days following their discovery (the “Notice Period”).
3. **Exceptions and Exclusions.** Notwithstanding anything herein to the contrary, the warranties set forth in Section 1 above do **not** cover any of the following, each of which are hereby expressly excluded therefrom:
 - A. Defects that are not discovered during the Warranty Period;
 - B. Defects that are not reported to Industrial Maid in writing within the Notice Period;
 - C. Usual and customary deterioration or wear resulting from normal use, service and exposure;
 - D. Consumable items such as filters, belts, and filter hammer are not warranted;
 - E. Any Components that are installed outside of the United States, Canada, or Mexico, United Kingdom and European Union;
 - F. Any fixtures, equipment, materials, supplies, accessories, parts, or Components that have been manufactured and/or furnished by any third party;
 - G. Any shortages in or damage to any Industrial Maid Components at delivery, all of which shall be exclusively governed by the invoice or Purchase Agreement;
 - H. The durability and/or variation in the appearance or color of Components;
 - I. Any Components which have been removed from the Industrial Maid unit on which they were originally installed;
 - J. The effect or influence any Industrial Maid Components may have on any pre-existing or other structures, including without limitation, any damage associated with loads imposed by the Industrial Maid Components on such structures;

- K. Any defect and/or any loss, damage, cost or expense incurred by Owner or any third party to the extent the same arise out of, relate to or result, in whole or in part, from any one or more of the following:
- i. Damage in transit or in handling;
 - ii. Theft, vandalism, accident, war, insurrection, fire or other casualty;
 - iii. Incorrect installation, servicing or operation;
 - iv. Defects or damage caused by Owner or any third party, including misuse, neglect or accident;
 - v. Exposure to marine environments, including frequent or sustained salt or fresh water spray;
 - vi. Operation beyond factory rated capacity;
 - vii. Exposure to corrosive, chemical, ash, smoke, fumes, or the like generated or released either within or outside of the structure on which the Components are installed from sources such as chemical plants, plating operations, foundries, kilns, fertilizer plants or paper plants regardless of whether or not such facilities are owned or operated by Owner or an unrelated third party;
 - viii. Any Industrial Maid Components that have been altered, modified or repaired by Owner or any third party without Industrial Maid's prior written consent;
 - ix. The placement or attachment of any fixtures, equipment, accessories, materials, parts or Components not furnished by Industrial Maid on or to any of the Industrial Maid Components without the prior written approval of Industrial Maid;
 - x. Exposure to or contact with animals, animal waste and/or decomposition;
 - xi. The failure of Owner and/or any third party to:
 - a. properly handle, transport and/or store any Industrial Maid Components;
 - b. properly select and prepare a location that is adequate for where the Industrial Maid Components will be installed;
 - c. properly erect and install the Industrial Maid Components, including, without limitation, installing an improper material or material containing defects that are detectable by visual inspection, or the failure to erect the Components in conformity with the Industrial Maid's Manuals;
 - d. properly design, construct and install all required heating, ventilation, air conditioning, and mechanical systems;
 - e. properly design, construct and install all required insulation systems; and/or
 - f. properly maintain, operate, and use, if applicable, any Industrial Maid Components either before or after installation.

4. Resolution of Warranty Claims. In the event Industrial Maid is notified of a warranty claim within the notice Period, in conformity with the notice requirements set forth in Section 2 above, Industrial Maid shall, with the full cooperation of Owner, immediately undertake an investigation of such claim. To the extent Industrial Maid shall determine, in its reasonable discretion, that the warranty claim is covered by the foregoing Limited Product Warranty, Industrial Maid will, as Owner's sole remedy provide:

- A. Parts only replacement: Ship replacement Components to the Owner as soon as is reasonably possible and at Industrial Maid's sole cost and expense. Industrial Maid shall not be responsible to Owner for the cost of dismantling any defective Components or installing replacement Components, all of which shall be and for all purposes remain the sole

responsibility of Owner.

5. **Warranty Not Transferable.** This Warranty applies to original Owner and is **not transferable**. As such, this Warranty does **not** cover any Industrial Maid's Components that are sold or otherwise transferred to third parties or any subsequent purchaser of the structure on which the Components are originally installed.
6. **Limitation on Warranties, Liabilities, and Damages.** Owner expressly agrees that the allocation of the risk, liability, loss, damage, cost, and expense arising from defects in the Components as set forth above are fair and reasonable and acknowledge that such allocation of risk was negotiated by the parties and was reflected in the Purchase Price of the Components. Accordingly, the Owner expressly agrees as follows:
 - A. **Disclaimer of Implied Warranties.** EXCEPT AS IS OTHERWISE EXPRESSLY SET FORTH HEREIN, INDUSTRIAL MAID MAKES NO OTHER REPRESENTATIONS OR WARRANTIES OF ANY KIND, WHETHER EXPRESS OR IMPLIED, BY OPERATION OF LAW OR OTHERWISE WITH RESPECT TO ANY GOODS OR SERVICES THAT INDUSTRIAL MAID SELLS OR PROVIDES TO OWNER INCLUDING WITHOUT LIMITATION ANY REPRESENTATION OR WARRANTY WITH RESPECT TO MERCHANTABILITY OR FITNESS FOR ANY PARTICULAR PURPOSE OR USE, SUCH WARRANTIES ARE EXPRESSLY DISCLAIMED.
 - B. **Limitation on Liability.** EXCEPT AS IS OTHERWISE EXPRESSLY SET FORTH IN SECTION 4 ABOVE, INDUSTRIAL MAID'S LIABILITY TO OWNER FOR ANY GOODS OR SERVICES WHICH DO NOT CONFORM TO THE WARRANTIES SET FORTH ABOVE SHALL NOT, IN ANY EVENT, EXCEED THE ACTUAL ORIGINAL COST PAID BY OWNER AS TO SUCH NON-CONFORMING COST OF SUCH NON-CONFORMING GOODS OR SERVICES.
 - C. **Limitation on the Nature of Damages.** EXCEPT AS EXPRESSLY PROVIDED IN SECTION 4 ABOVE, INDUSTRIAL MAID SHALL NOT, UNDER ANY CIRCUMSTANCES, BE LIABLE TO OWNER OR ANY THIRD PARTY FOR ANY SPECIAL, INDIRECT, INCIDENTAL, CONSEQUENTIAL, LIQUIDATED OR PUNITIVE DAMAGES OF ANY NAME, NATURE OR DESCRIPTION. INDUSTRIAL MAID IS NOT RESPONSIBLE FOR LOSS OF USE, LOSS OF TIME, INCONVENIENCE FOR ANY REASON.
7. **Applicable Law.** This Standard Limited Warranty shall be governed by, and construed in accordance with, the internal laws of the State of Nebraska, USA. Any legal action or proceeding arising under or with respect to this Agreement shall be brought only in the district courts of Nebraska, or the United States District Court for the District of Nebraska. Industrial Maid and Owner each hereby accepts for itself and in respect of its property, generally and unconditionally, the jurisdiction of the aforesaid courts and each hereby irrevocably waives any objection thereto, including, without limitation, personal jurisdiction or forum non conveniens.

This Limited Product Warranty gives you specific legal rights. No agent, employee, or representative of Industrial Maid, nor any dealer, installer, fabricator, or other person is authorized to modify this Warranty in any respect. The invalidity of all or a part of any of the provisions of this Limited Product Warranty shall not affect or invalidate any other provision of this Limited Product Warranty. Questions about this Limited Product Warranty may be directed to Industrial Maid, email: sales@industrial-maid.com, phone: 1-877-624-3247 or visit our website at industrial-maid.com.