



**INDUSTRIAL MAID**  
AIR FILTRATION AND VENTILATION PRODUCTS

# Owners Manual

## AZTech Model 2000C COMMERCIAL AIR CLEANER



### Contents

Safety/Inspection .....	2
Specifications.....	3
Installation.....	4
Replacement Parts .....	6
Electrical .....	7
Troubleshooting/Notes .....	8
Warranty .....	14

## SAFETY

### **PLEASE READ THE FOLLOWING INSTRUCTIONS CAREFULLY BEFORE INSTALLING, OPERATING OR SERVICING YOUR AIR CLEANER.**

Follow all building and safety codes when installing this equipment. Pertaining but not limited to, the Occupational Safety and Health Act (OSHA), National Electric Code (NEC), Uniform Building Code (UBC), National Fire Prevention Act (NFPA) & all state and local codes.

A qualified electrician should perform all electrical connections.

Keep Flammable Objects away from the air cleaner and under no condition should a burning object be allowed into the air cleaning system.

Do not mix materials collected in your Air Cleaner. The captured materials could create a hazardous environment or a condition of operation for which the equipment is not intended. The Manufacturer is relieved of any liability if the unit is not operated according to this manual.

Do not use the Air Cleaner for an application other than for which it was intended. Consult your distributor, Applicable Codes, or call Industrial Maid for application assistance.

A fire suppression system is not included. Please consult your local fire protection specialist for any required extinguishing equipment.

Consult with your insurance underwriter about any other protection from fire damages.

The Manufacturer reserves the right to make design changes, which may improve the air cleaner.

This unit is intended for use to collect ambient smoke, airborne pollutants, and fumes in industrial and manufacturing facilities. Do not use for the collection of flammable or explosive metals, dust, fumes, or other potentially hazardous materials.

## INSPECTION

Upon receiving your Industrial Maid air cleaner, please inspect for any damage incurred during shipment. Inspect carefully; some damage may not be noticeable until the unit is installed. Notify your shipper of any damage immediately. Claims must be filed with the shipper within 15 days. Freight damage claims are the responsibility of the purchaser.

## SPECIFICATIONS

Cabinet	14 ga powder coated steel frame. 3/16 polyethylene panels(14 ga steel panels, optional)
Size	25”H x 48.5”L x 25”D
Weight	120 lbs.
Power	115 /1/60    9.1 FLA
Air Volume	2,300 CFM High, 2,100 CFM Low
Motor	3/4 HP PSC Type, Overload Protected, 2 speed
Blower	10 x 10 Direct Drive DWDI Forward Curve
Exhaust	Four Way adjustable louver
Filters	Prefilter - 4” pleated filter Main Filter - 95% multi-pocket bag 2” Carbon Filter
Warranty	3 year limited warranty

## INSTALLATION

The system's weight must be taken into account when choosing the proper installation method (see specification). Follow all applicable building and electrical codes.

There are two main ways of installing your Model 2000C air cleaner, Chain Hanging (eye bolts factory installed as option), or angle braces. Figure 2 illustrates these methods.

Figure 1.  
(shown with optional silencer)

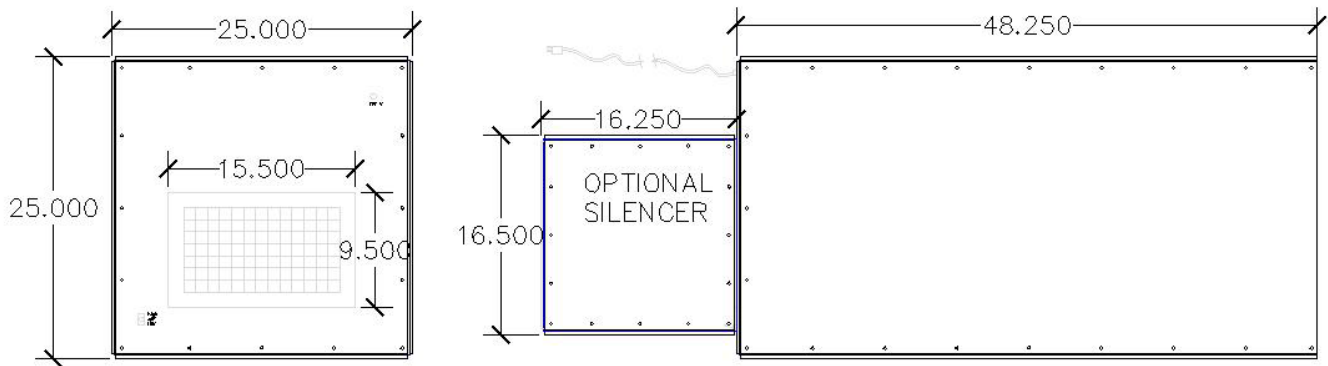
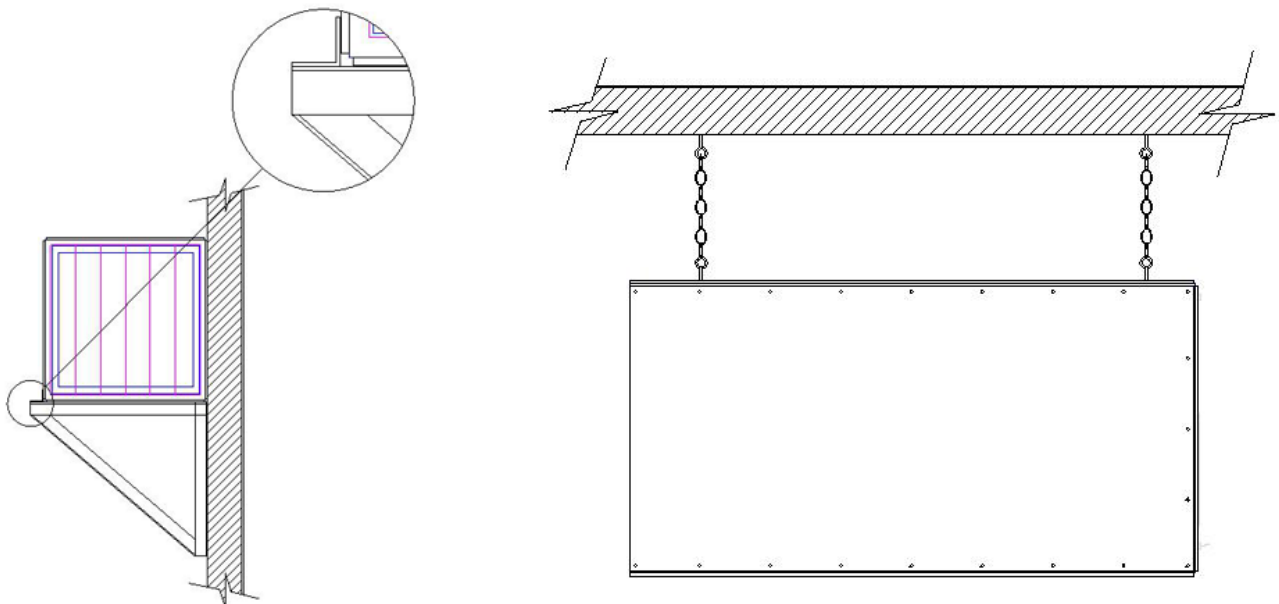

Figure 2.



Mounting materials must be able to support the weight of the air cleaner plus the additional weight of the material collected. Consult your local building code for proper installation methods and materials. Failure to use the proper materials could result in injury or damage equipment and will void the warranty.

## Manometer Installation Instructions (ambient application)

**STEP 1** - Mount gauge in desired location, using the two screws provided. Typically, gauges are mounted on the side of the unit or on a wall close to the air cleaner. (keep in mind you have a limited amount of hose). Drill (2) 1/8" holes on the cabinet or another vertical surface, on a vertical line 3-15/16" apart. Loosely attach using the self tapping screws pro-vided.

**STEP 2** - Level using the built in spirit level. Tight screws.

**STEP 3** - Drill a 3/8 hole in cabinet in a location after the final filter in the system (between filter header and blower as illustrated below) and attach provided brass nipple, nut, and washer.

**STEP 4** - Attach provided hose to brass nipple and low port on gauge (see figure A below).  
NOTE: you will only use one side of the provided double hose for this application!

**STEP 5** - Fill the gauge with the provided fluid, slightly past the 0 mark, then adjust to 0 with the zero set knob.

**STEP 6** - Turn on the air cleaner and mark the starting point with the green arrow as shown. Next, place the red arrow at a point 1" higher than the starting point. This is the point at which you will need to service your air cleaner.

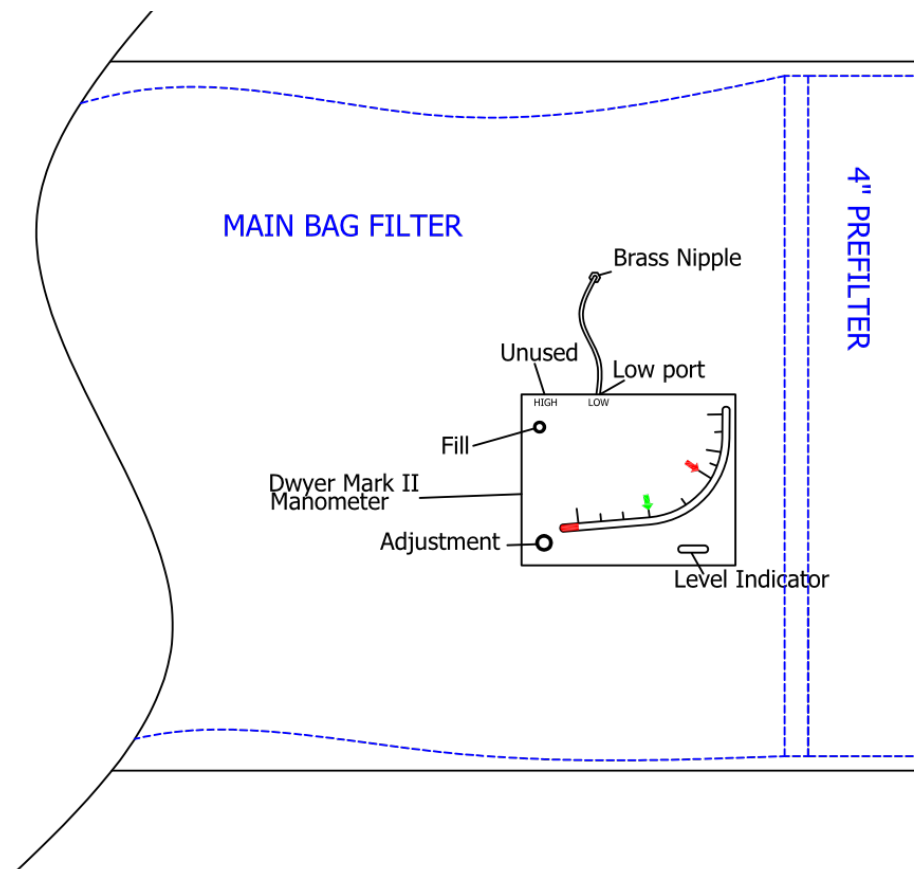

## REPLACEMENT PARTS

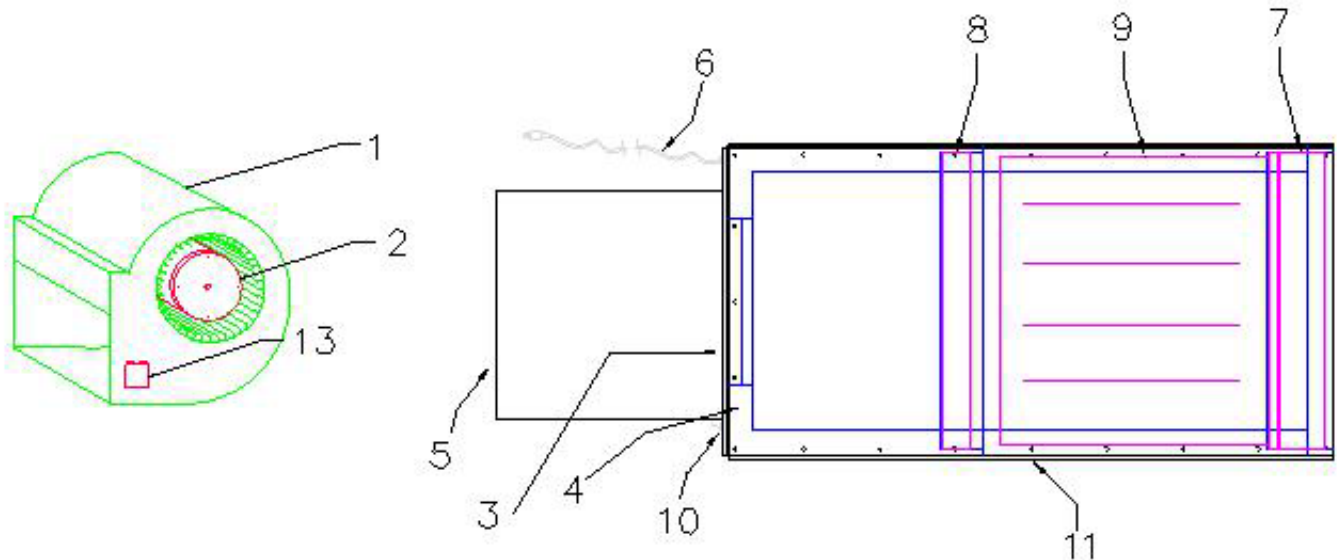
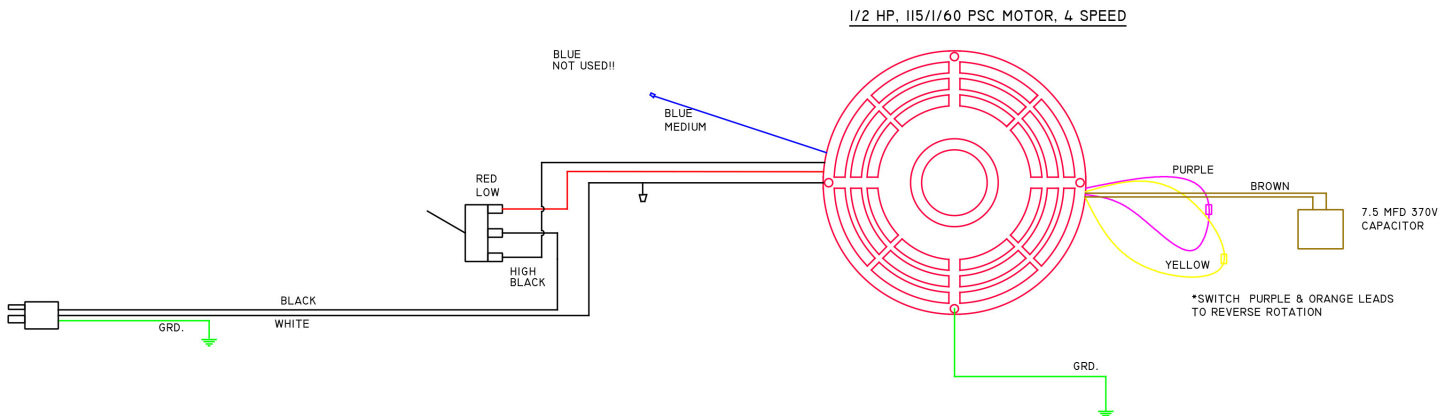

Figure 4

ITEM	PART NUMBER	QTY	DESCRIPTION
1	BW10-DD10	1	BLOWER ASSEMBLY
2	MT41-1013	1	3/4 HP MOTOR, 115V, 3 SPEED
3	GR07-0013	1	EXHAUST GRILLE
4	FR25-ASSY	1	14 GA FRAME ASSY
5	FR25-SILR	1	OPTIONAL SILENCER ASSY
6	ELCD-1415	1	14/3 POWER CORD, 12 FT
7	FP44-2424	1	4" PLEATED PREFILTER
8	FC02-2424	1	24X24X2 CARBON PANEL
9	FB98-2424	1	95% FIBERGLASS BAG FILTER *
10	ELSW-1012	1	SPEED SWITCH, 15 AMP ON/OFF/ON
11	250000-11PE	4	POLYETHYLENE PANELS, ALL 4 SIDES
12	250000-10PE	1	POLYETHYLENE PANELS, EXHAUST END
13	MT41-CP10	1	3/4HP CAPACITOR

\* FILTER EFFICIENCIES BASED ON ASHRAE TEST METHODS

## ELECTRICAL WIRING



Unit comes complete with switch and cord, wired for 115/1/60 service. Additional wiring may be required to get power to unit, which is not supplied with this product. All Field wiring should be performed by a qualified electrician and must meet all local and NEC codes. Failure to install the proper electrical wiring and controls will void the warranty.

Rotation - Rotation is set at the factory. To reverse rotation, switch the black and white leads on the rotation plug directly on the motor as shown above.

OPTIONAL TEAO Motors - Use the following chart for the totally enclosed motor option:

- High speed - Black
- Low speed - Yellow
- Rotation leads - Black & White
- Medium/high & Medium/low - Not Applicable

## CONNECTING POWER TO MOTOR

To connect motor for proper voltage and rotation, refer to the connection diagram on the nameplate or inside the terminal/conduit box.

### Minimum Wire Sizes for Shaded Pole and PSC Motors

Motor HP	25 Feet		50 Feet		100 Feet		150 Feet		200 Feet	
	115V	230V	115V	230V	115V	230V	115V	230V	115V	230V
1/12	14(18)*	14(18)*	14(18)*	14(18)*	14	14(18)*	14	14(18)*	12	14(18)*
1/10	14(18)*	14(18)*	14(18)*	14(18)*	14	14(18)*	12	14(18)*	12	14(18)*
1/8	14(18)*	14(18)*	14(16)*	14(18)*	14	14(18)*	12	14(18)*	10	14(16)*
1/6	14(18)*	14(18)*	14(16)*	14(18)*	14	14(18)*	12	14(18)*	10	14(16)*
1/5	14(18)*	14(18)*	14(16)*	14(18)*	12	14(18)*	12	14(18)*	10	14(16)*
1/4	14(18)*	14(18)*	14	14(18)*	12	14(18)*	10	14(16)*	8	14
1/3	14(16)*	14(18)*	14	14(18)*	10	14(16)*	10	14(16)*	8	14
1/2	14(16)*	14(18)*	14	14(18)*	10	14(10)*	8	14	8	14
3/4	14	14(18)*	12	14(18)*	8	14	6	12	6	12
1	14	14(18)*	10	14(16)*	8	14	6	12	4	10
1 1/2	12	14(18)*	10	14(16)*	6	14	4	10	4	10

#### NOTE:

NEC Article 310-5 --- Minimum conductor size for general wiring at 115-440VAC is No. 14AWG.

Above wire sizes based on approximate 5% voltage drop during starting; copper conductors; and 75° C type THHW, THW, THWN, RH, RHW insulation, etc. For aluminum wire, increase two AWG wire sizes larger minimum. See NEC Article 310 for ampacities of aluminum conductors.

Type S, SO, SJ, SJO, etc. Flexible cable wire sizes. See NEC Article 400 for ampacity





### DANGER

**Before performing any maintenance, disconnect power and allow the motor to come to a complete stop. Discharge capacitors, if any, for safety.**

Remove dirt accumulations in and around vent openings, by vacuuming. **Dirt accumulations can cause motor overheating and a fire hazard.** Enclosed motors can be cleaned with an air jet; wear eye protection.

Periodically inspect the installation. Check for dirt accumulations; unusual noises or vibration; overheating; worn or loose couplings, sheaves, and belts; high motor current; poor wiring or overheated connections; loose mounting bolts or guards; and worn motor starter contacts.

Exercise caution with solvents; some solvents may attack motor insulation, finish or bearing lubricants; some are highly flammable. If solvents are used, make sure the area is well ventilated.

Bearing motors require periodic re-oiling. Follow re-oiling instructions on the motor (see nameplate or terminal box cover). If instructions are not included, re-oil continuous duty units once a year, intermittent duty units every two years, and occasional duty units every five years with 30 to 35 drops of SAE No. 20 non-detergent or electric motor oil. Do not over lubricate.

## MOTOR TROUBLESHOOTING

This chart suggests common answers to electric motor problems. The information is not all-inclusive and does not necessarily apply in all cases. When unusual operating conditions, repetitive failures, or other problems occur, consult an electric motor service firm.

Symptom	Possible Cause(s)	Corrective Action
<b>Motor fails to start</b>	1. Blown fuses	1. Replace with time-delay fuses. Check for grounded winding
	2. Tight shaft	2. Occasionally during shipment a sleeve bearing motor may be received with a shaft that does not rotate freely. It may be necessary to strike the motor at the shell/endshield rabbet with a rawhide or plastic mallet to align the bearings
	3. Voltage too low at motor terminals due to line drop	3. Consult the local power company. Increase wire size (refer to Minimum Wire Size Table). Check for poor connections
	4. If a permanent split capacitor motor, the capacitor may be defective	4. Indicated by humming sound. Replace the run capacitor. See nameplate for correct value
	5. Overload (internal thermal protector) tripped	5. Check the motor load. If the motor has an automatic reset thermal protector, turn off power, allow the motor to cool
	6. Improper line connections	6. Check connections against the diagram supplied with motor
	7. Motor may be overloaded. Defective motor or starter.	7. Repair or replace
<b>Motor does not come up to speed or takes too long to accelerate</b>	1. Not applied properly	1. Consult motor service firm for proper type. Use larger motor
	2. Voltage too low at motor terminals	2. Increase wire size (refer to Minimum Wire Size Table). Check for poor connections

Symptom	Possible Cause(s)	Corrective Action
	3. Starting load too high	3. Check load motor is carrying at the start
	4. Excess loading; tight belts	4. Reduce load; increase motor size. Adjust belts
	5. Defective motor.	5. Replace or repair
	6. Inadequate starting torque. High inertia load	6. Replace with a larger motor
<b>Insufficient speed change</b>	1. Insufficient motor load	1. Use a lower horsepower motor. Reduce system restrictions (blower). Increase system restrictions (propeller fan)
<b>Motor stalls during operation</b>	1. Overloaded motor	1. Reduce load or increase the motor size
	2. Low motor voltage	2. Verify that nameplate voltage is maintained
<b>Motor vibrates or is excessively noisy</b>	1. Motor shaft is misaligned	1. Realign
	2. Loose or defective or out-of-balance fan blade or blower wheel	2. Tighten setscrew(s); repair or replace fan blade or blower wheel
	3. Worn, damaged, dirty or overloaded bearings	3. Repair or replace motor; check loading and alignment
	4. Defective winding. Bent or bowed shaft	4. Replace motor
<b>Motor overheats while running under load</b>	1. Overloaded	1. Reduce load; increase motor size; belts may be too tight
	2. Dirt blocking ventilation openings	2. Clean motor
	3. Faulty connection	3. Clean, tighten, or replace
	4. High or low voltage	4. Check voltage at motor, should not be more than 10% above or below rated
	5. Defective motor	5. Repair or replace

## BLOWER MAINTENANCE

At least once per year, clean and inspect the blower assembly.

1. Remove dirt from blower wheel and housing
2. Check tightness of wheel set screw.
3. After disconnecting the power source, check the wiring to see if it is secure and well insulated.
4. Relubricate motor per manufacturer's instructions. Remove any excess lubricants

### BLOWER TROUBLESHOOTING CHART

Symptom	Possible Cause(s)	Corrective Action
<b>Excessive noise</b>	1. Blower wheel in contact with housing	1. Realign or replace
	2. Foreign material inside housing	2. Clean
	3. Leak in duct work	3. Repair
	4. Loose duct work	4. Secure properly
<b>Insufficient air flow</b>	1. Motor speed too low (multi-speed units only)	1. Make speed adjustment
	2. Leaks in duct work	2. Repair
	3. Dampers and/or registers closed	3. Open
	4. Obstruction in system	4. Remove
	5. Clogged filters	5. Clean or replace
<b>Too much air flow</b>	1. Filters not in place	1. Install filters
	2. Motor speed too fast (multi-speed units only)	2. Lower speed
	3. Registers or grilles not installed	3. Install to match system requirement
	4. Insufficient static pressure (SP)	4. Check your static pressure (SP) calculations and correct system accordingly
<b>Unit fails to operate</b>	1. Blown fuse or open circuit breaker	1. Replace fuse or reset circuit breaker
	2. Defective motor capacitor	2. Replace capacitor
	3. Defective motor	3. Replace motor
<b>Motor overloaded</b>	1. System static pressure too low	1. Check and correct system

# SERVICE RECORD

Date	Description	Serviced By	Location	Comments



351 S. 12th Rd.  
Cortland, NE 68331  
Ph. (402) 798-7116  
Fx. (402) 798-7117  
[www.industrial-maid.com](http://www.industrial-maid.com)  
[sales@industrial-maid.com](mailto:sales@industrial-maid.com)

## WARRANTY

1. **Limited Product Warranty.** Industrial Maid, LLC, 351 S. 12th Rd., Cortland, NE, 68331, hereby warrants to any owner who has purchased the equipment other than for purposes of resale, as follows:
  - A. All components of air cleaners and air filtration equipment manufactured (collectively “Components”) by Industrial Maid, as well as motors and drives installed on Industrial Maid units (collectively “Components”) will be manufactured in conformity with stated materials, dimensions, and tolerances;
  - B. Components manufactured by Industrial Maid, as well as motors and drives installed in Industrial Maid units, will, in normal use and service, be free from defects in material and workmanship for a period of thirty-six (36) months;
  - C. Components not manufactured by Industrial Maid (other than motors and drives) are not included within the thirty-six (36) month Warranty. These excluded items include HMI Control Panels, motor starters, disconnects, filters, duct work, and installation not supplied by Industrial Maid. The Limited Product Warranty on these items, when sold by Industrial Maid as part of the unit, is twelve (12) months and parts only.
  - D. Upon delivery, Industrial Maid will convey good and marketable title to the Components to Owner free and clear of all liens and encumbrances other than those arising in favor of Industrial Maid, including the purchase money security interest.
2. **Duration of Warranty/Notice Requirements.** The warranties set forth in Section 1 above shall apply to covered defects in Components that are discovered by Owner within the respective thirty-six (36) months or twelve (12) months following the Invoice Date (the “Warranty Period”) and are reported to Industrial Maid in writing within thirty (30) calendar days following their discovery (the “Notice Period”).
3. **Exceptions and Exclusions.** Notwithstanding anything herein to the contrary, the warranties set forth in Section 1 above do **not** cover any of the following, each of which are hereby expressly excluded therefrom:
  - A. Defects that are not discovered during the Warranty Period;
  - B. Defects that are not reported to Industrial Maid in writing within the Notice Period;
  - C. Usual and customary deterioration or wear resulting from normal use, service and exposure;
  - D. Consumable items such as filters, belts, and filter hammer are not warranted;
  - E. Any Components that are installed outside of the United States, Canada, or Mexico, United Kingdom and European Union;
  - F. Any fixtures, equipment, materials, supplies, accessories, parts, or Components that have been manufactured and/or furnished by any third party;
  - G. Any shortages in or damage to any Industrial Maid Components at delivery, all of which shall be exclusively governed by the invoice or Purchase Agreement;
  - H. The durability and/or variation in the appearance or color of Components;
  - I. Any Components which have been removed from the Industrial Maid unit on which they were originally installed;
  - J. The effect or influence any Industrial Maid Components may have on any pre-existing or other structures, including without limitation, any damage associated with loads imposed by the Industrial Maid Components on such structures;

- K. Any defect and/or any loss, damage, cost or expense incurred by Owner or any third party to the extent the same arise out of, relate to or result, in whole or in part, from any one or more of the following:
- i. Damage in transit or in handling;
  - ii. Theft, vandalism, accident, war, insurrection, fire or other casualty;
  - iii. Incorrect installation, servicing or operation;
  - iv. Defects or damage caused by Owner or any third party, including misuse, neglect or accident;
  - v. Exposure to marine environments, including frequent or sustained salt or fresh water spray;
  - vi. Operation beyond factory rated capacity;
  - vii. Exposure to corrosive, chemical, ash, smoke, fumes, or the like generated or released either within or outside of the structure on which the Components are installed from sources such as chemical plants, plating operations, foundries, kilns, fertilizer plants or paper plants regardless of whether or not such facilities are owned or operated by Owner or an unrelated third party;
  - viii. Any Industrial Maid Components that have been altered, modified or repaired by Owner or any third party without Industrial Maid's prior written consent;
  - ix. The placement or attachment of any fixtures, equipment, accessories, materials, parts or Components not furnished by Industrial Maid on or to any of the Industrial Maid Components without the prior written approval of Industrial Maid;
  - x. Exposure to or contact with animals, animal waste and/or decomposition;
  - xi. The failure of Owner and/or any third party to:
    - a. properly handle, transport and/or store any Industrial Maid Components;
    - b. properly select and prepare a location that is adequate for where the Industrial Maid Components will be installed;
    - c. properly erect and install the Industrial Maid Components, including, without limitation, installing an improper material or material containing defects that are detectable by visual inspection, or the failure to erect the Components in conformity with the Industrial Maid's Manuals;
    - d. properly design, construct and install all required heating, ventilation, air conditioning, and mechanical systems;
    - e. properly design, construct and install all required insulation systems; and/or
    - f. properly maintain, operate, and use, if applicable, any Industrial Maid Components either before or after installation.

**4. Resolution of Warranty Claims.** In the event Industrial Maid is notified of a warranty claim within the notice Period, in conformity with the notice requirements set forth in Section 2 above, Industrial Maid shall, with the full cooperation of Owner, immediately undertake an investigation of such claim. To the extent Industrial Maid shall determine, in its reasonable discretion, that the warranty claim is covered by the foregoing Limited Product Warranty, Industrial Maid will, as Owner's sole remedy provide:

- A. Parts only replacement: Ship replacement Components to the Owner as soon as is reasonably possible and at Industrial Maid's sole cost and expense. Industrial Maid shall not be responsible to Owner for the cost of dismantling any defective Components or installing replacement Components, all of which shall be and for all purposes remain the sole

responsibility of Owner.

5. **Warranty Not Transferable.** This Warranty applies to original Owner and is **not transferable**. As such, this Warranty does **not** cover any Industrial Maid's Components that are sold or otherwise transferred to third parties or any subsequent purchaser of the structure on which the Components are originally installed.
6. **Limitation on Warranties, Liabilities, and Damages.** Owner expressly agrees that the allocation of the risk, liability, loss, damage, cost, and expense arising from defects in the Components as set forth above are fair and reasonable and acknowledge that such allocation of risk was negotiated by the parties and was reflected in the Purchase Price of the Components. Accordingly, the Owner expressly agrees as follows:
  - A. **Disclaimer of Implied Warranties.** EXCEPT AS IS OTHERWISE EXPRESSLY SET FORTH HEREIN, INDUSTRIAL MAID MAKES NO OTHER REPRESENTATIONS OR WARRANTIES OF ANY KIND, WHETHER EXPRESS OR IMPLIED, BY OPERATION OF LAW OR OTHERWISE WITH RESPECT TO ANY GOODS OR SERVICES THAT INDUSTRIAL MAID SELLS OR PROVIDES TO OWNER INCLUDING WITHOUT LIMITATION ANY REPRESENTATION OR WARRANTY WITH RESPECT TO MERCHANTABILITY OR FITNESS FOR ANY PARTICULAR PURPOSE OR USE, SUCH WARRANTIES ARE EXPRESSLY DISCLAIMED.
  - B. **Limitation on Liability.** EXCEPT AS IS OTHERWISE EXPRESSLY SET FORTH IN SECTION 4 ABOVE, INDUSTRIAL MAID'S LIABILITY TO OWNER FOR ANY GOODS OR SERVICES WHICH DO NOT CONFORM TO THE WARRANTIES SET FORTH ABOVE SHALL NOT, IN ANY EVENT, EXCEED THE ACTUAL ORIGINAL COST PAID BY OWNER AS TO SUCH NON-CONFORMING COST OF SUCH NON-CONFORMING GOODS OR SERVICES.
  - C. **Limitation on the Nature of Damages.** EXCEPT AS EXPRESSLY PROVIDED IN SECTION 4 ABOVE, INDUSTRIAL MAID SHALL NOT, UNDER ANY CIRCUMSTANCES, BE LIABLE TO OWNER OR ANY THIRD PARTY FOR ANY SPECIAL, INDIRECT, INCIDENTAL, CONSEQUENTIAL, LIQUIDATED OR PUNITIVE DAMAGES OF ANY NAME, NATURE OR DESCRIPTION. INDUSTRIAL MAID IS NOT RESPONSIBLE FOR LOSS OF USE, LOSS OF TIME, INCONVENIENCE FOR ANY REASON.
7. **Applicable Law.** This Standard Limited Warranty shall be governed by, and construed in accordance with, the internal laws of the State of Nebraska, USA. Any legal action or proceeding arising under or with respect to this Agreement shall be brought only in the district courts of Nebraska, or the United States District Court for the District of Nebraska. Industrial Maid and Owner each hereby accepts for itself and in respect of its property, generally and unconditionally, the jurisdiction of the aforesaid courts and each hereby irrevocably waives any objection thereto, including, without limitation, personal jurisdiction or forum non conveniens.

This Limited Product Warranty gives you specific legal rights. No agent, employee, or representative of Industrial Maid, nor any dealer, installer, fabricator, or other person is authorized to modify this Warranty in any respect. The invalidity of all or a part of any of the provisions of this Limited Product Warranty shall not affect or invalidate any other provision of this Limited Product Warranty. Questions about this Limited Product Warranty may be directed to Industrial Maid, email: sales@industrial-maid.com, phone: 1-877-624-3247 or visit our website at industrial-maid.com.