





















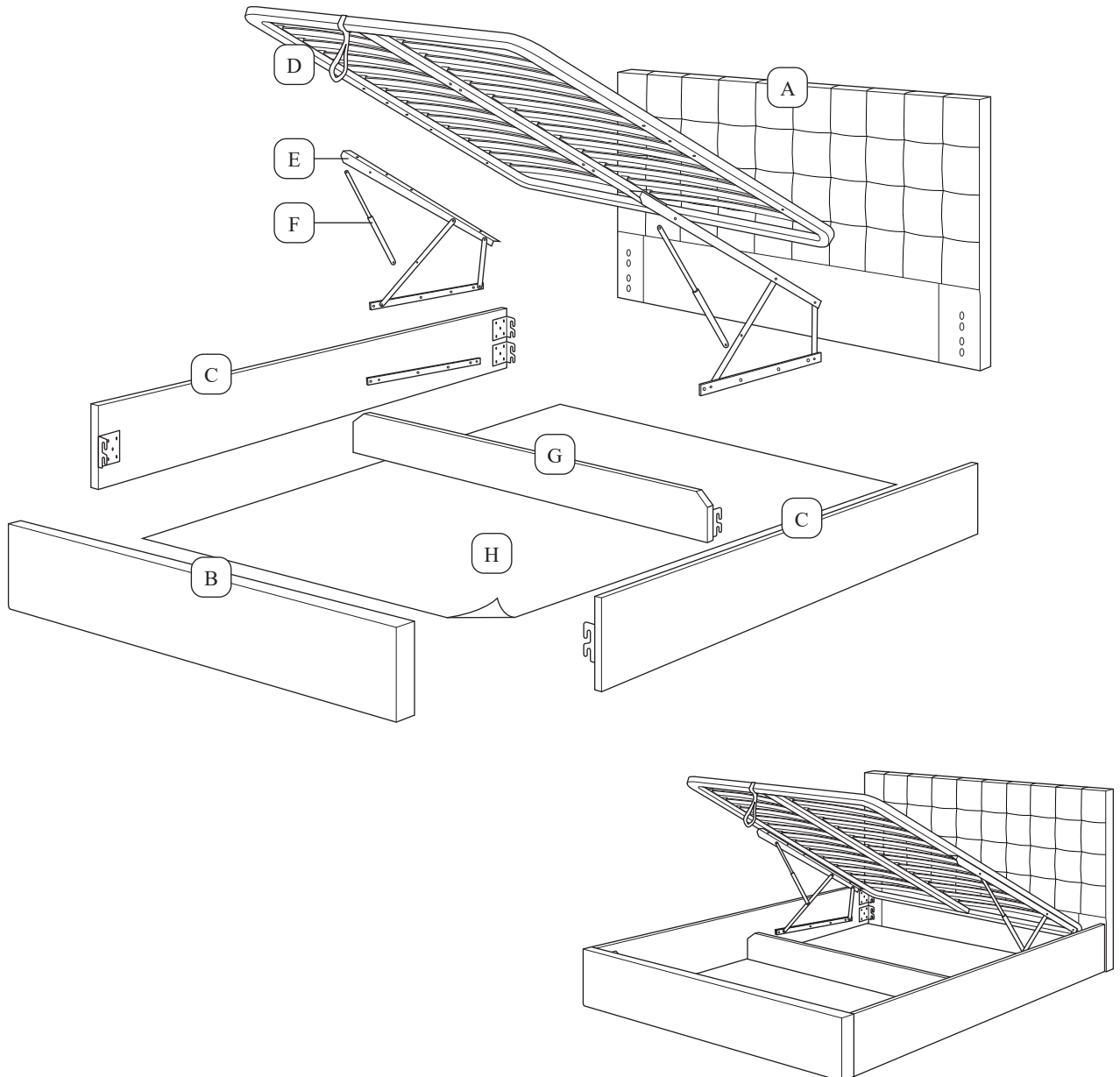

No	Part List	Qty
A	Headboard	1 pc
B	Footboard	1 pc
C	Side Rail	2 pcs
D	Metal Frame Bed Set	1 set
E	Hydraulic Base Support	2 pcs
F	Hydraulic Pump	2 pcs
G	Cross Bar	1 pc
H	Bottom Base Fabric	1 pc

No	Hardware List	Qty
1	JCBB M8 x 16mm 	14 pcs
2	JCBB M8 x 20mm 	12 pcs
3	JCBB M8 x 40mm 	8 pcs
4	JCBB M8 x 45mm 	8 pcs
5	PH CSK M8 x 45mm 	20 pcs
6	M8 Flat Washer 	8 pcs
7	M8 Hex Nuts 	28 pcs
8	Allen Key M5 	1 pc
9	M8 Spanner 	1 pc
10	Small Slat Holder 	26 pcs
11	Large Slat Holder 	13 pcs
12	L-Shape Metal Corner Bracket 	2 pcs
13	L-Shape Metal Bracket 	1 pc
14	Belt 	1 pc

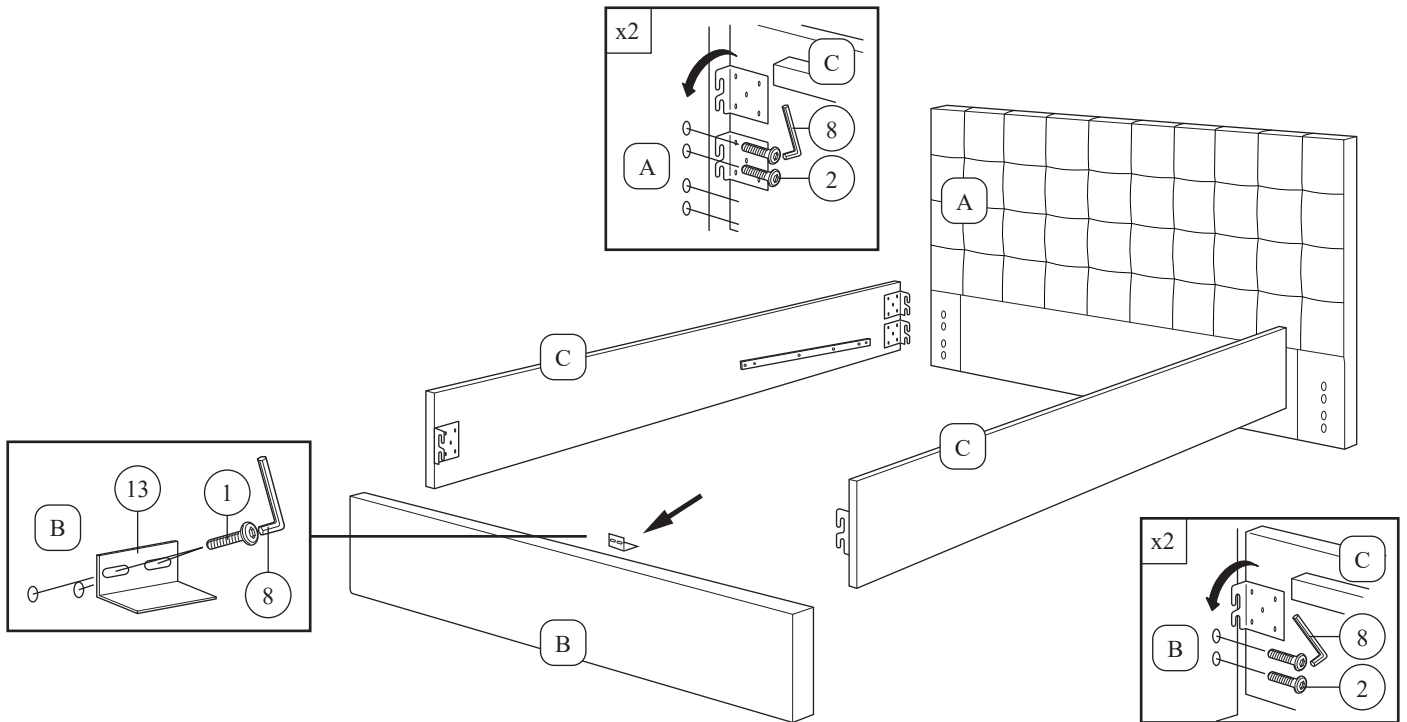

1	JCBB M8 x 16mm		2 pcs
2	JCBB M8 x 20mm		12 pcs
8	Allen Key M5		1 pc
13	L-Shape Metal Bracket		1 pc





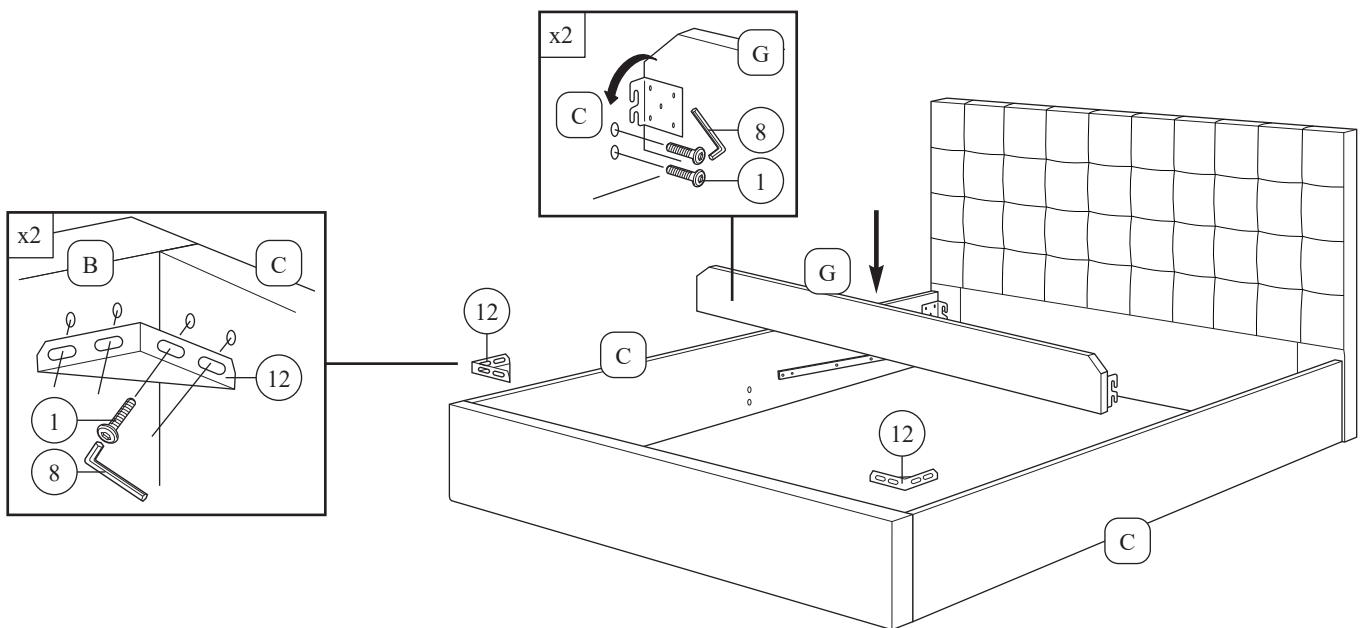

1	JCBB M8 x 16mm		12 pcs
8	Allen Key M5		1 pc
12	L-Shape Metal Corner Bracket		2 pcs

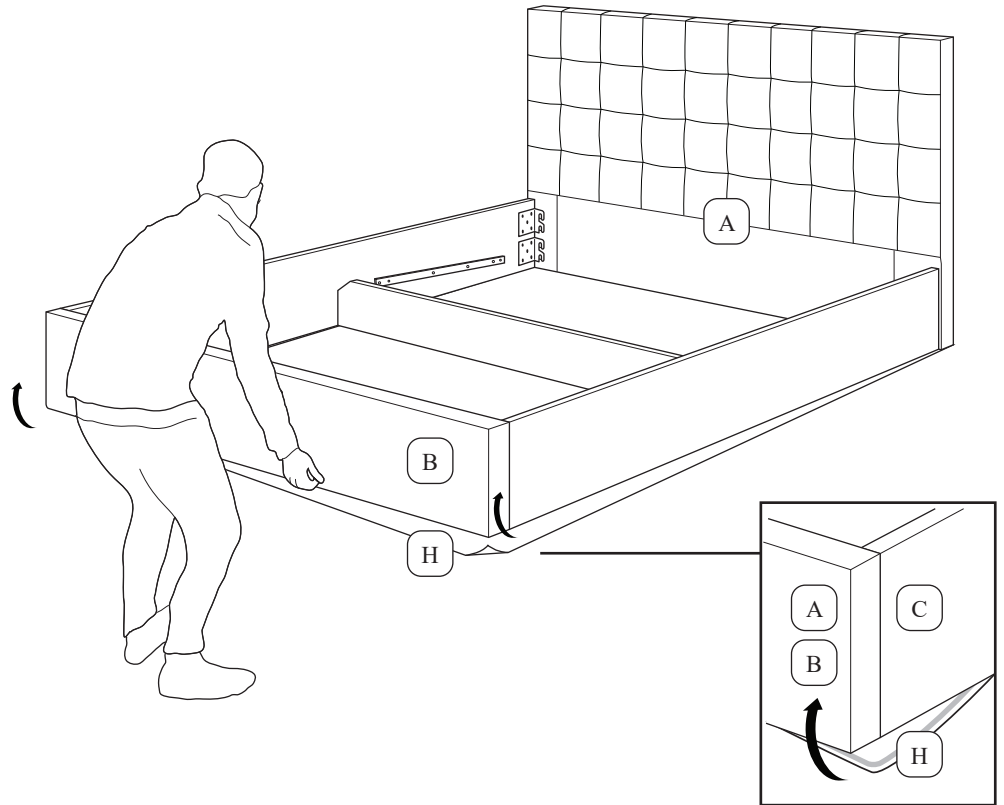
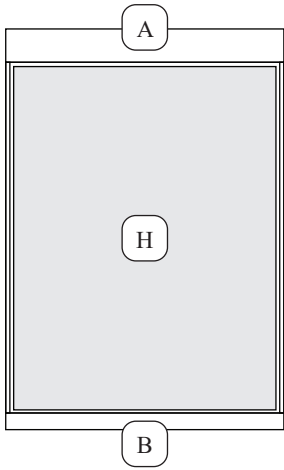





Do Not Use Power Tools

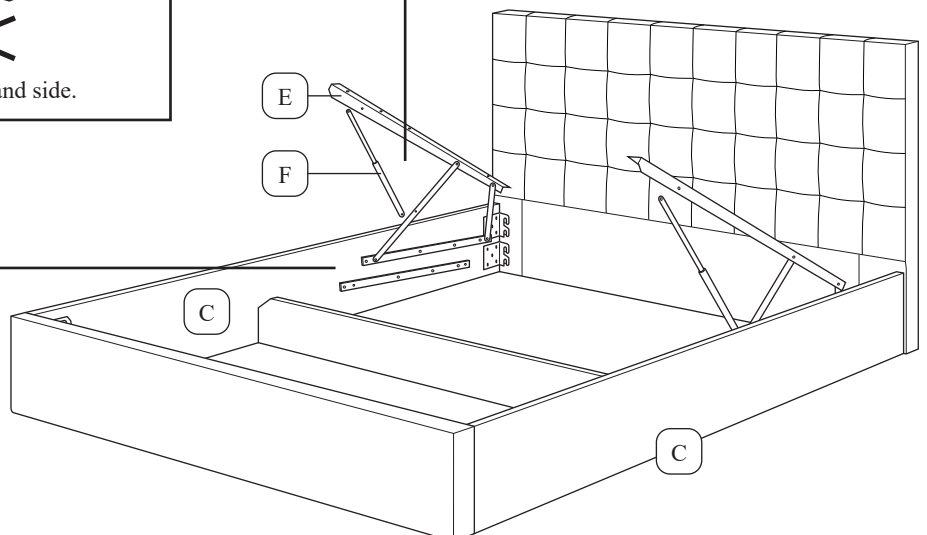
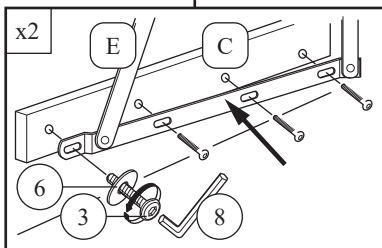
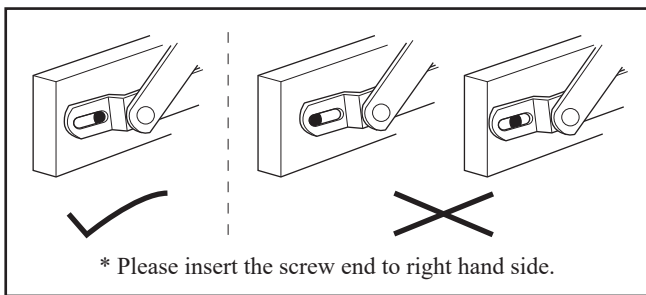
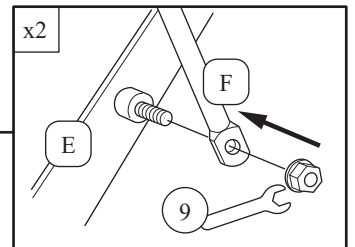
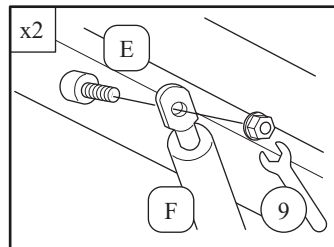

3	JCBB M8 x 40mm		8 pcs
6	M8 Flat Washer		8 pcs
8	Allen Key M5		1 pc
9	M8 Spanner		1 pc







Do Not Use Power Tools

5	PH CSK M8 x 45mm		10 pcs
7	M8 Hex Nuts		10 pcs
9	M8 Spanner		1 pc
14	Belt		1 pc

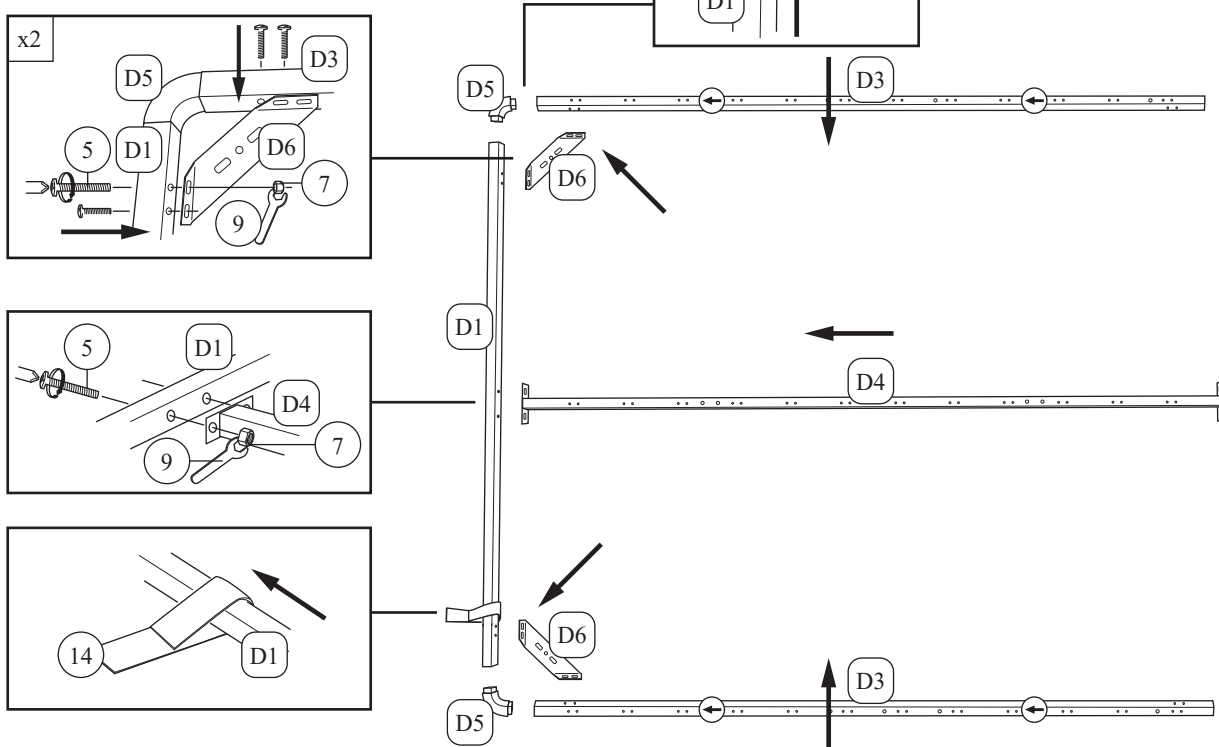
WARNING

Please make sure assemble the metal follow the same hole direction as per label.



5	PH CSK M8 x 45mm		10 pcs
7	M8 Hex Nuts		10 pcs
9	M8 Spanner		1 pc

WARNING



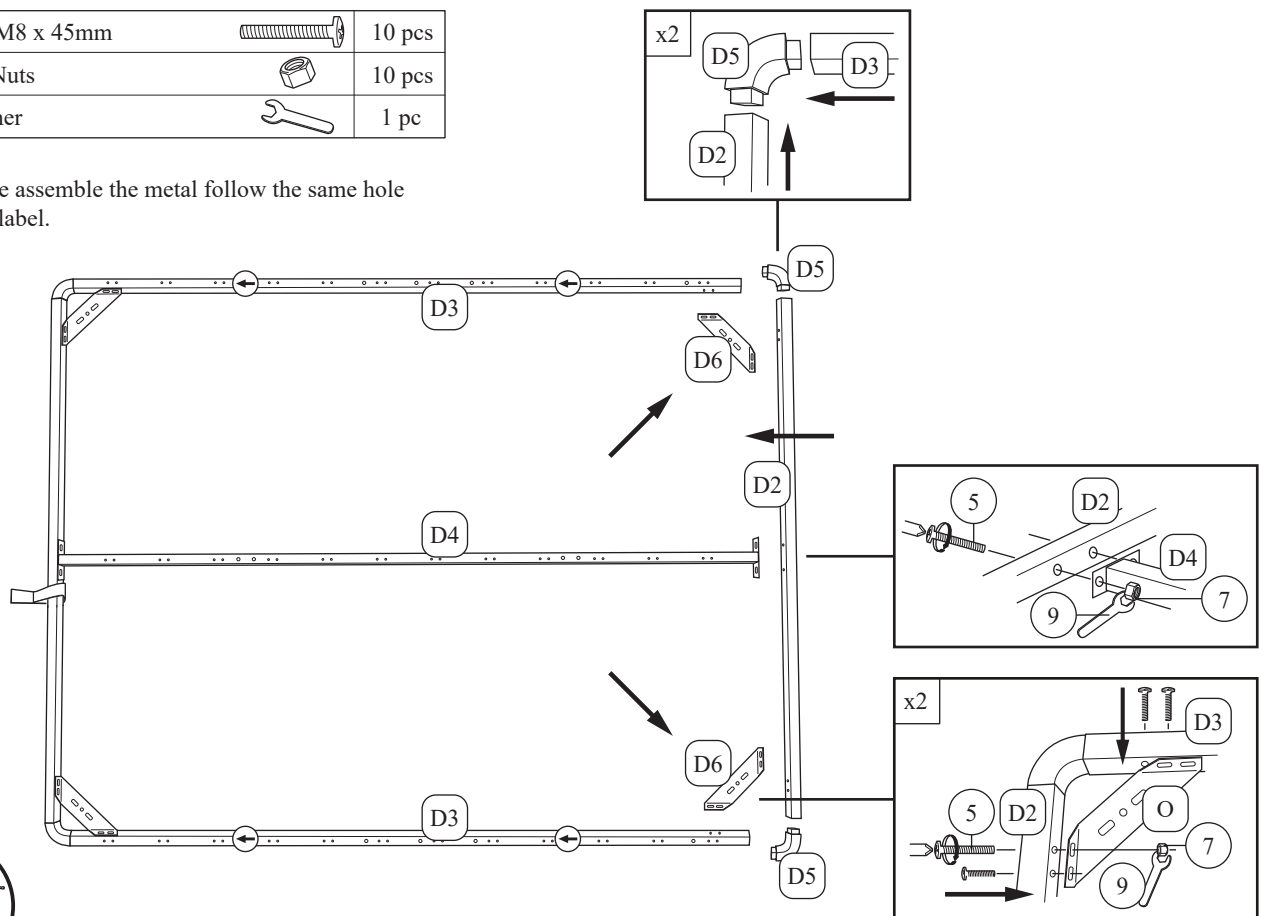

Please make sure assemble the metal follow the same hole direction as per label.

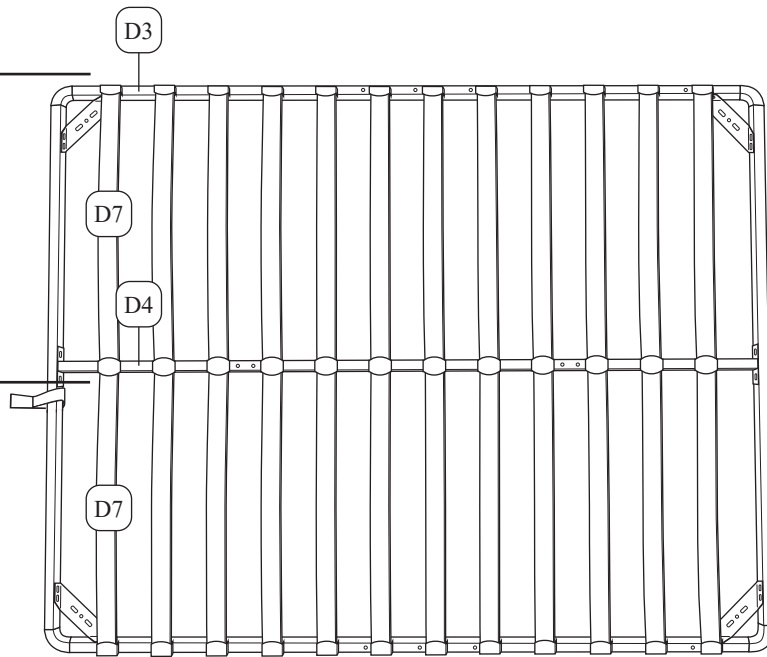
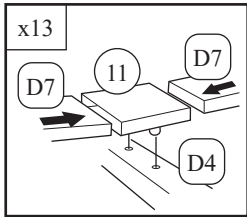
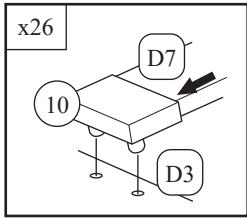

Do Not Use Power Tools

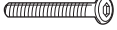
10	Small Slat Holder		26 pcs
11	Large Slat Holder		13 pcs



4	JCBB M8 x 45mm		8 pcs
7	M8 Hex Nuts		8 pcs
8	Allen Key M5		1 pc
9	M8 Spanner		1 pc

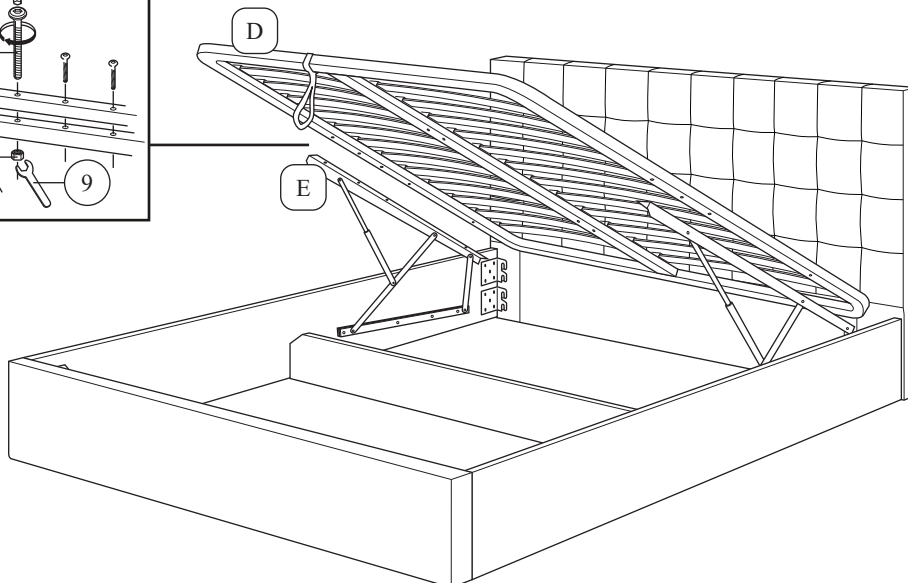
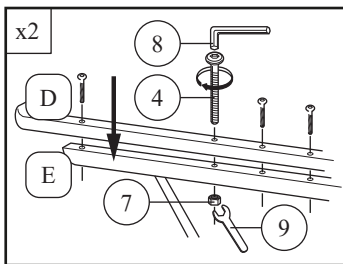
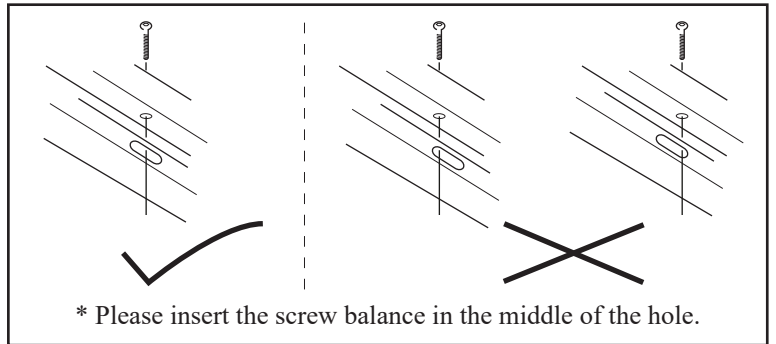

Do Not Use Power Tools