

ELECTRIC ACTUATOR MOD. VB015 MAINTENANCE AND INSTALLATION INSTRUCTIONS OF VALBIA ELECTRIC ACTUATORS

TABLE OF CONTENTS

- 1.0 - WARNINGS
- 2.0 - GENERAL DATA
 - 2.1 - TECHNICAL CHARACTERISTICS
 - 2.2 - DATA ON ELECTRICAL SUPPLY AND CONSUMPTION
- 3.0 - FIELD APPLICATION
- 4.0 - ELECTRICAL CONNECTION
 - 4.1 - OPENING COVER OF ELECTRIC ACTUATOR
 - 4.2 - ELECTRICAL CONNECTION 12-24 V AC/DC
 - 4.3 - ELECTRICAL CONNECTION 100-240V AC
 - 4.4 - CONNECTION OF SIGNAL AUXILIARY WIRES TO THE LIMIT SWITCHES
 - 4.5 - WIRING DIAGRAM
 - 4.6 - ADJUSTMENT OF ACTUATOR STROKE
 - 4.7 - CLOSURE OF ELECTRIC ACTUATOR COVER
- 5.0 - EMERGENCY OPERATION
 - 5.1 - WORKING IN EMERGENCY WITH BATTERY (OPTIONAL)
- 6.0 - MAINTENANCE
- 7.0 - VALVE AUTOMATION
- 8.0 - TRANSPORT AND STOCKING

1.0 Warnings

- Please read the following instructions before making any installation of the actuator
The damages caused from the non-observance of these instructions are not covered in the warranty.
This documentation must be kept in dry place and available for use.
The installation and maintenance of electric actuator must be made only by qualified personnel.
- Before proceeding to the electrical connections, please make sure the ground wiring system works correctly.
- Please always check that supply voltage is included between the ones indicated on the label on the exterior of the actuator.
- Before making any maintenance on the actuator, always make sure to shut off the power supply.
- Valbia s.r.l. reserves the right to change the data and the characteristics of this manual at any time and with no notice in the scope of a constant updating of technological improvement.

2.0 General data

DOCUMENTATION	UNIT		VALUE	
Object of device	-		Electric actuator	
Construction type	-		Electronic control integrate device	
Protection level of cover	-		IP65	
Cover type (UL50)	-			
Ambient temperature range	°C	°F	-20°C ÷ 55°C	-4°F ÷ +131°F
Rated voltage used (auxiliary contacts)	V		240 Vac / 30 Vdc	
Rated current (auxiliary contacts)*	A		1 A @ 240Vac - 1 A @ 30 Vdc (resistive load)	
Section of connections clamps' conductors	mm ²		0,5 - 1,5	
Maximum torque of clamps screws' tightening	Nm	Lb.In	0,5	4,43
Maximum torques of cap screws' tightening	Nm	Lb.In	2,5	22,15
Protection class against electric shock	-		Class II	
Blocking way of cables	-		Glandes PG11	
Restriction of continue operation time (internal restrictions)	sec.		120	
Action type	-		Type 1	
Level of pollution	-		Level III	
Category of overvoltage	-		III	

* Only for model 85L0BS01 microswitches (for auxiliary contacts) rating 0.1A@125/250 Vac - 0.1A@30 VDC.

Product in conformity to the Community norm 2006/95/CE (LVD), 2004/108/CE (EMC).

USE 60° C/75° C COPPER (Cu) CONDUCTOR AND WIRE SIZE 14 AWG, STRANDED OR SOLID. THE TERMINAL TIGHTENING TORQUE OF (6) LB PER IN.

2.1 Technical characteristics

- The electric actuator VB015 has the heating resistor standard, always supplied.
- Both the versions of the actuators, 12-24V ac/dc and 100-240Vac, have 24V motor. If the actuator has to face a torque higher than the foreseen maximum torque then the actuator block it self and keep a state of "stress" from the electronic circuit of power control.
- The options at 12V and 24V AC/DC, in case the torque go over the maximum one foreseen, are projected to block automatically the actuator by taking off the electrical supply to the motor.
- This status keeps the electric actuator steady until a new impulse will be processed.

2.2 Supply data elec./consumption

MOD.	VB015		
Nominal tension	12V ac/dc	24V ac/dc	100-240V ac
Nominal torque (Nm) (Lbs)	15 133		
Current absorbed	1,2A	0,6A	0.3-0.19A
Absorbed power	15VA	15VA	30-46 VA
Frequency	50/60 Hz		
Rotation time 0°-90° (sec)	10	10	10

3.0 Field application

VALBIA electric actuators have been designed and tested to operate ball and butterfly valves for industrial sector. Actuators are available in standard version with rotation 0°-90°.

On request we can supply actuators with rotation 0°-180°.

For applications other than that above are needed please contact the VALBIA engineering.

4.0 electrical connection

The connection has be done directly into the internal part of the actuator, by passing the cable through one of the two external glands PG11 (IP68). It is then necessary to open the upper cover in order to locate the terminal-block and the correct electronic supply.

Please pay attention to the cabling and setting phases of electromechanical limit switches in order to avoid that fluids or other substance do not get in touch with any electronic part.

Before assembling the upper cover please make sure that the o-ring is seated in the proper groove and there are no other instructions which could compromise the perfect tightness of cover.

ATTENTION: Valbia electric actuators can work in any position, anyhow we do not suggest application where glandes are positioned up side-down, because this position could not guarantee a perfect tightness on glandes.

In case the assembling of electric actuator and the electrical connection of itself are scheduled to be made in two different moments then please take care of the right closure of the glandes entrance.

4.1 Opening of actuator (fig.1)

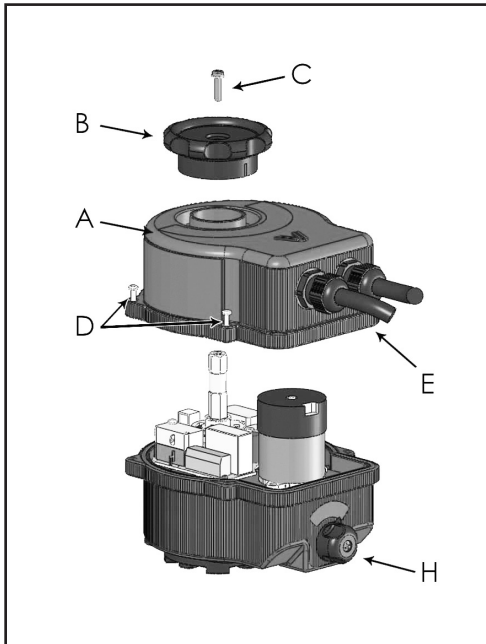

Fig.1 External view of actuator

Remove position indicator (B) by loosening the screws (C).

- Screw the fasteners (D) to remove the upper cover (A).

- Raise up the cover (A) carefully to avoid to damage the internal electric parts.

- Turn in the electric supply cable (diam. 6 ÷ 9 mm / 0,24±0,35 inch) by the properly bolts (E) (PG11).

- Proceed to connect the cable in its proper terminal-block (F) by looking at the wiring diagram (please also review the tag you find inside the cover) according to the different voltage (see 4.2 and 4.3).

4.2 Electrical connection (fig. 2)

Electrical connection for model supplied with 12 AND 24V AC 50/60 Hz

- The signal cable of "closing" (clockwise rotation) must be connected to the contact "1" (terminal block "F")
- The signal cable of "opening" (counter-clockwise rotation) must be connected to the contact "2" (terminal-block "F").
- The cable of "neutral" must be connected to the contact "3" (terminal-block "F")
- For supplying the heating resistor connect the contact "4" (terminal-block "F") as show the electric wiring

Electrical connection for model supplied with 12 AND 24V DC

- Connect the contact "1" to the contact "2" (terminal block "F")
- Connect the contact "1" to the contact "4" for supplying the heater.
- To get the control of "opening " (counter-clockwise rotation) please connect the positive pole to the contact "1" and the negative pole to the contact "3" (terminal block "F").
- To get the control of "closing" (clockwise rotation) please connect the negative pole to the contact "1" and the positive pole to the contact "3" (terminal block "F").
- For supplying the heating resistor connect the contact "4" (terminal-block "F") as show the electric wiring

ATTENTION : the electric actuator VB015 has the double insulation and if supplied at 12 and 24 V DC then it does not need of ground wiring system.

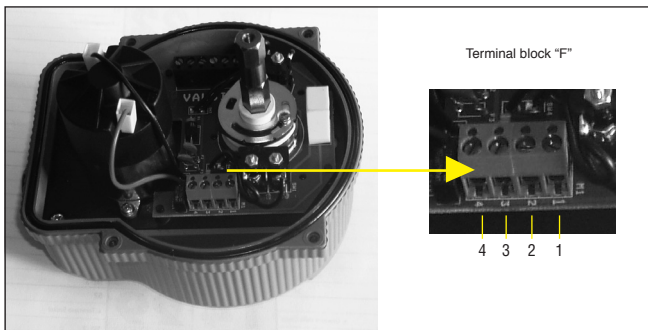

Fig.2 Plate for supply 12 and 24V AC/DC and particular of terminal block "F"

4.3 Electrical connection for models with supply at 100-240V AC 50/60Hz (fig. 3)

- The signal cable of "closure (clockwise rotation)" (signal of phase) must be connected to the input 1 of the terminal block "F".
- The signal cable of "opening (counter-clockwise rotation)" (signal of phase) must be connected to the input 2 of the terminal block "F".
- The signal cable of "common" must be connected to the contact 3 of the terminal block "F".
- The supply cable (100-240V AC) has to be linked to the contacts 5-6.
- The heating resistor is automatically powered by electronics.

ATTENTION: the electric actuator VB015 has the double insulation and if supplied at 100-240V AC then it does not need of ground wiring system. Avoid to connect external voltages to contacts 1-2-3 of the terminal block "F"

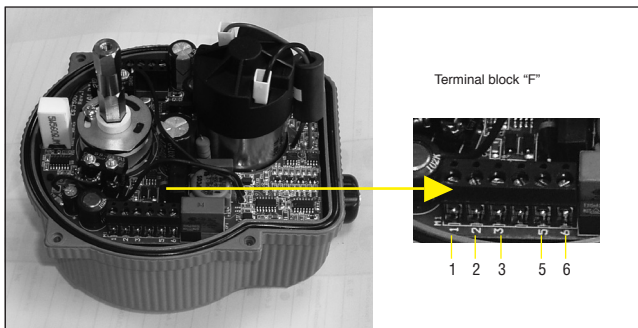

Fig.3 Plate of supply 100-240V AC and particular of terminal block "F"

4.4 Connection of signal auxiliary wires to the limit switches (fig.4)

These are 2 auxiliary contacts of limit switches (free contact) available on the terminal block "G" which is possible to connect to give signals to the end user.

-To connect to the terminal block "G" between the contacts:

- "7" and "8" to get the signal of closure.

- "11" and "12" version 12-24V ac/dc - "10 and 11" version 100-240V ac to get the signal of opening .

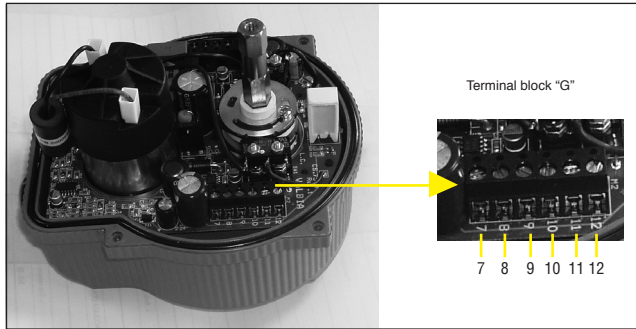

Fig.4 View of terminal block "G" to connect to auxiliary signals

4.5 Wiring diagram (fig.5)

The following figure shows the wiring diagram (also it is, as tag, inside the cover) to be followed for the proper cabling to the actuators. When the limit switches POS1 and POS2 are pressed they stopped the motor and so the opening and closing operation.

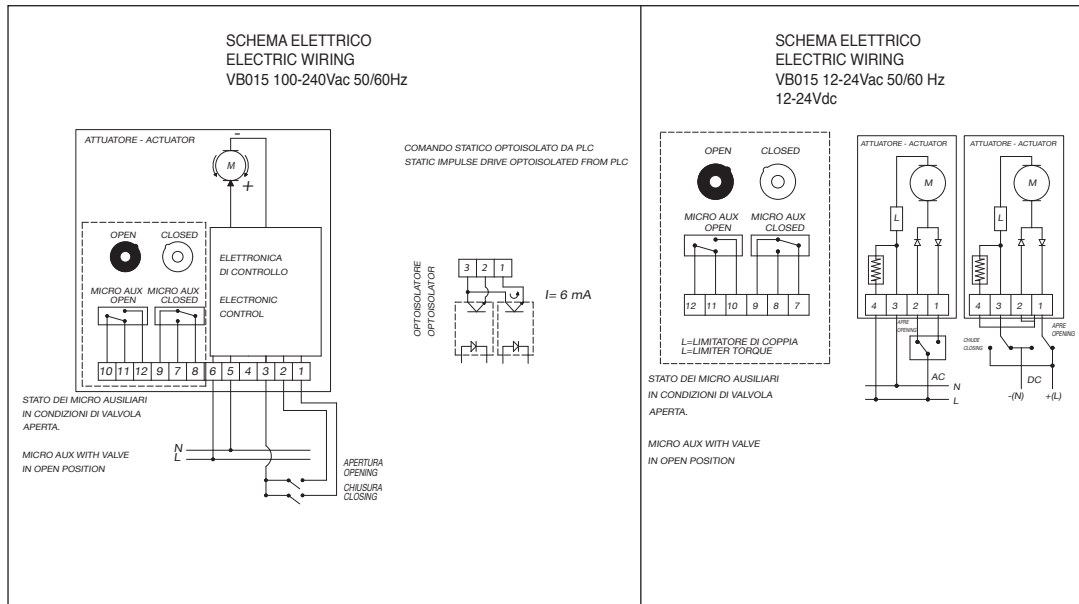

Fig. 5 Electric wiring diagram to cable the actuators

4.6 Adjustment of actuator stroke (fig.6)

The procedures to adjust the actuator stroke are as follows:

1. Take care there is not electrical supply
2. Remove the upper cover of the actuator (see instructions point 4)
3. Take care that the device to be automatised (example: valve) is on "OPEN" position
4. The electric actuator VB015 has 2 discs camholder, the upper one "2"orders the micro limit switches to control "open" and "closed", while the bottom one "1" orders the auxiliary limit switches used to give the signal of opening and closure. For each camholder there is a black cam, (opening rotation) and a white cam (closure rotation), the two cams are tightened by a screws "3".

N.B. If you use the auxiliary contacts of limit switches please take care of their conditions by using a tools of electrical continuity.

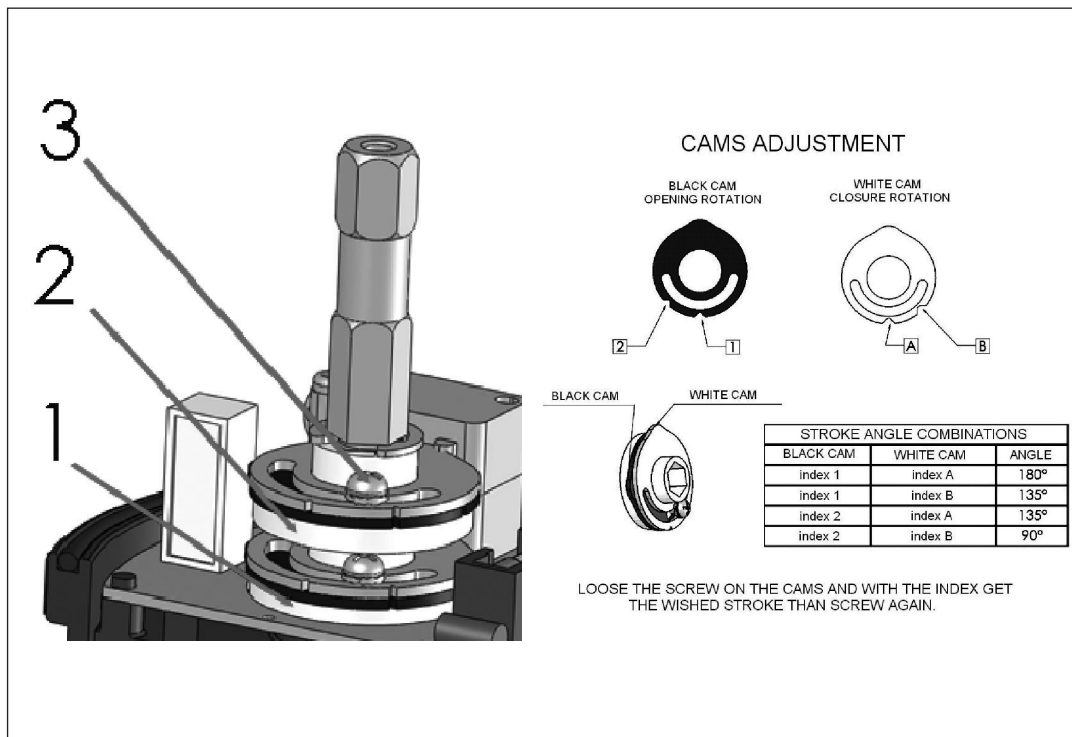

Fig. 6 . Cams of the limit switch

4.7 Electric actuator case closing (fig.1)

- After making the proper connection, please proceed to the assembling of cover "A", by paying close attention not to hit any electronic parts.
- Re-assemble the position indicator "B" on "OPEN " blocking it by screw "C".
- Make sure that the tightening of cables is secure, by screwing the gland "E".
- Finish the closure of the cover "A" by screwing in the fasteners "D".

5.0 Emergency operation

The electric actuator VB015 has an external handwheel "B" with position indicator, by which is possible to operate manually the closing and opening operations.

The manual operation operates by working on the external handle "H" by turning it to the position "MAN", at this point is possible to make the manual operation you like by working on handwheel "B".

To return to the automatic position please turn the handle "H" to position "AUTO".

Attention: do not operate the manual override when the actuator is working.

6.0 Maintenance

These electric actuators do not need of any format maintenance.

The internal lubrication is sufficient for the whole life of the actuator.

To get a good cleaning of the external parts, we suggest to use a light detergent with low level of chemical aggressiveness.

In case of damage or a problem in operation, we recommend that you send the actuators back to Valbia for inspection.

Valbia s.r.l. declines all responsibility and warrantee on our actuators repaired from any third party

7.0 Valve automation

The mechanical assembling between the electric actuator and the item to be automated (for example: the valve) can be done by direct mounting or by a mounting kit.

Both the cases you can verify the right alignment and the correct dimensions of the part to transmit the power in order to avoid axial stress which can damage valve and actuator.

All Valbia electric actuators are in conformity of norm EN ISO 5211-DIN 3337.

In order to have a right automation of the valve, is necessary to use a Valbia electric actuators whose range has a torque of at least 25% over the valve maximum torque.

Do not raise up or moved the motorized valve by using the electric actuator as point of grip or hold.

8.0 Transport and stocking

Valbia electric actuators are supplied in paperboard boxes which are of solid construction for a normal transport.

Please handle and keep with care the cover until the moment of the installation of the actuator.

The stocking of the material needs a dry and well ventilated place. Please take care also that it must be protected from temperature changes.