

SERIE XKS-S/SW

Bomba de drenaje para uso doméstico, de construcción robusta y provista de retenes de estanqueidad. Indicada para el vaciado de estanques, pozos, depósitos, piscinas, etc. Completamente de material anticorrosivo; Boquilla de impulsión roscada.

Drain pump for home use, robust and provided with seal rings construction. Suitable for emptying ponds, wells, reservoirs, pools, etc. Strongly corrosive material; Threaded drive nozzle.

Pompe de vidange pour un usage domestique, robuste et muni d'anneaux d'étanchéité construction. Convient pour vider les étangs, les puits, les réservoirs, piscines, etc. Matériau fortement corrosive; Buse filetée d'entraînement.



XKS serie SW



XKS serie S

Materiales

Cuerpo aspiración	INOX
Cuerpo impulsión	INOX
Impulsor	PPO / PA6
Difusor	PP
Eje rotor	INOX 304
Envolvente	INOX
Cierre mecánico	Retén
Rejilla aspiración	INOX
Tornillería	INOX 304

Rango de trabajo

Protección	IP 68
Aislamiento	Clase F
Inmersión máx.	5 m
Temperatura	35°C
Fluidos	Agua turbia

Materials

Inlet body	SS
Outlet body	SS
Impeller	PPO / PA6
Diffuser	PP
Rotor shaft	SS 304
External casing	SS
Mechanical seal	Locker
Suction grid	SS
Screws	SS 304

Working range

Protection	IP 68
Isolation	Class F
Immersion	5 m
Temperature	35°C
Fluids	Turbied water

Matériels

Corps d'aspir.	INOX
Corps d'impuls.	INOX
Roue	PPO / PA6
Diffuseur	PP
Arbre	INOX 304
Enveloppe	INOX
Garniture méc.	Bloquer
Gille	INOX
Vis	INOX 304

Plage de travail

Protection	IP 68
Isolement	Classe F
Immersion	5 m
Température	35°C
Fluides	Eau trouble

CURVAS Y PUNTOS DE SERVICIO

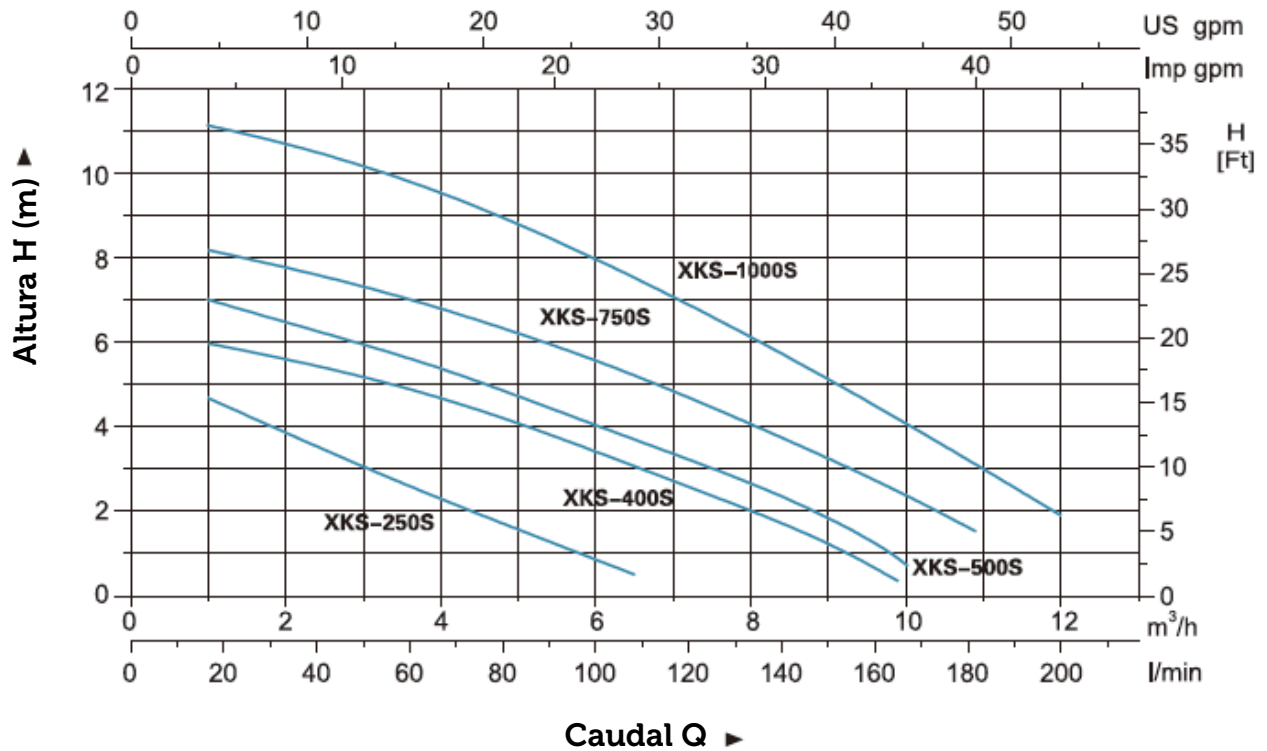

MODELO MODEL MODÈLE	DN [ø"]	SÓLIDOS SOLIDS SOLIDES [mm]	INTENSIDAD [A] CURRENT [A] INTENSITÉ [A]		POTENCIA POWER PUISSANCE		CONDENSADOR CAPACITOR CONDENSATEUR [μF]	PESO WEIGHT POID [Kg]
			1~220V	3~400V	KW [P ₂]	Hp [P ₂]		
XKS-250S	1	5	1,0	-	0,25	0,33	4	4,6
XKS-401S	1	5	2,2	-	0,37	0,5	10	5,2
XKS-750SW	1	32	5,2	-	0,75	1,0	14	4,0
XKS-1000SW	1	32	6,0	-	1,0	1,3	16	5,0

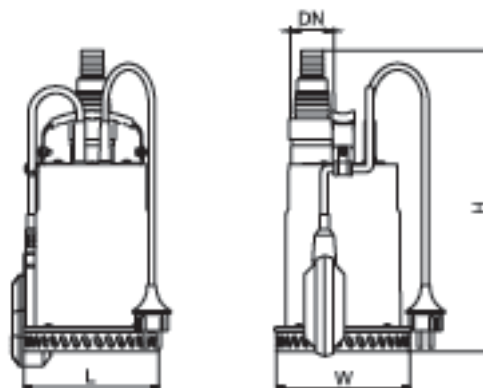

MODELO MODEL MODÈLE	DN [ø"]	L [mm]	W [mm]	H [mm]	PESO WEIGHT POID [Kg]
XKS-250S	1	151	151	323	4,6
XKS-401S	1	151	151	323	5,2
XKS-750SW	1	151	151	331	4,0
XKS-1000SW	1	151	151	347	5,0

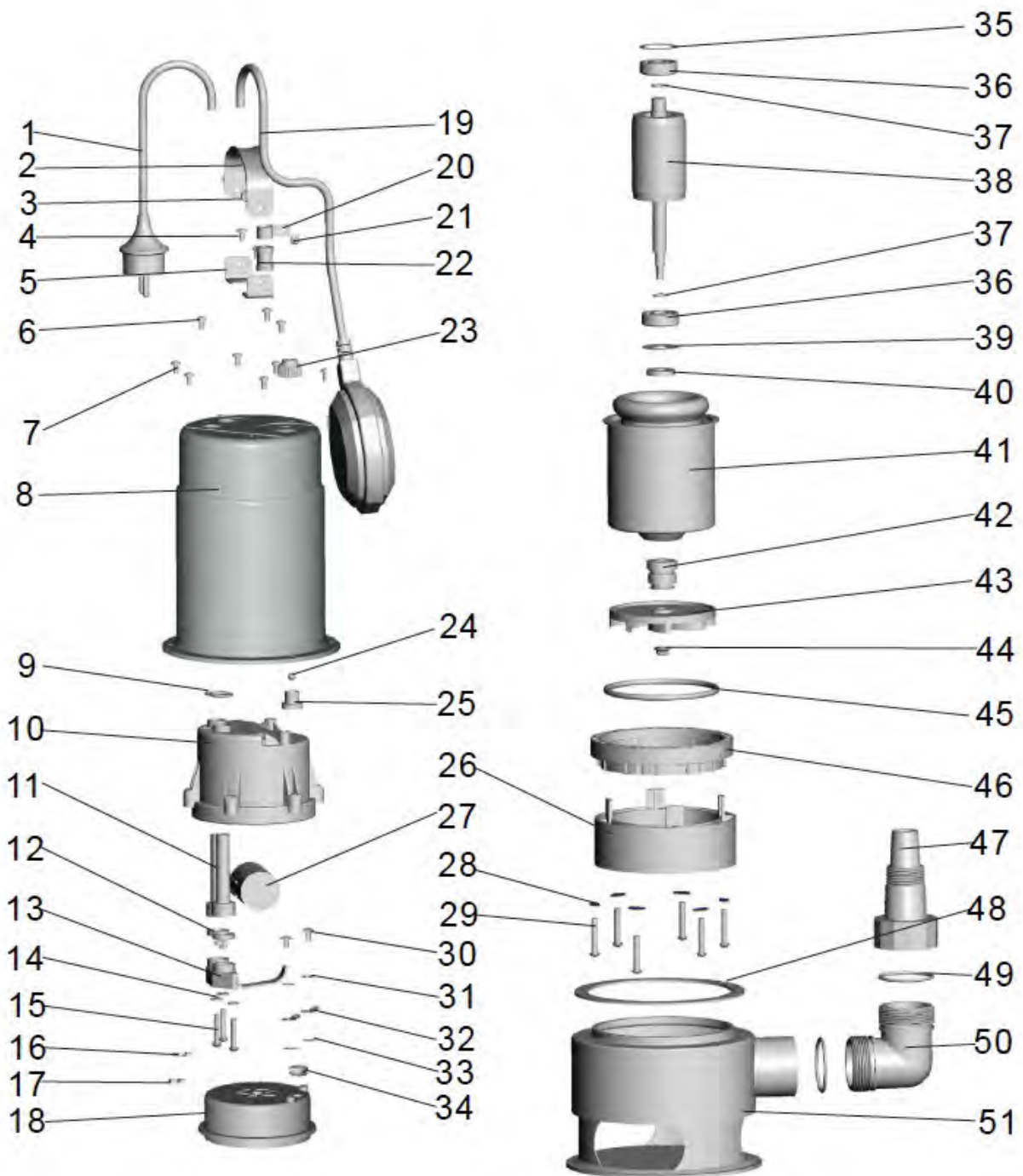

No.	Description	No.	Description	No.	Description	No.	Description
1	Cable	14	Plain cushion	27	Capacitor	40	Framework seal
2	Handle	15	Screw	28	Compacting washer	41	Motor stator
3	Hexagonal nut	16	Terminal piece	29	Screw	42	Mechanical seal
4	Screw	17	Terminal piece	30	Screw	43	Impeller
5	Hanging ring	18	Upper plate	31	Spring washer	44	Hexagonal nut
6	Screw	19	Float switch	32	Cable compacting	45	Seal ring
7	Screw	20	Wire clip	33	Lock washer	46	Pressure ring
8	Pump cover	21	Screw	34	Wire lead holder	47	Connector
9	Seal ring	22	Wire clip jacket	35	Valve spring	48	Gasket
10	Upper cover	23	Screwcap	36	Ball bearing	49	Seal ring
11	Cable jacket	24	Steel ball	37	Clip for shaft	50	Universal fitting
12	Cable clip	25	Valve base	38	Rotor	51	Pump body
13	Capacitor clip	26	Pump support	39	Adjusting washer		