

# OWNER'S MANUAL

## ASL PRO 8

Propane Concrete Grinder and Polisher



Version 1.051618

**Made in the USA**

9328 Wheatlands Rd Suite A Santee, CA 92071  
(866) 275 0446 • [info@ASLMachinesUSA.com](mailto:info@ASLMachinesUSA.com)

[ASLMachinesUSA.com](http://ASLMachinesUSA.com) • [facebook.com/aslmachinesusa](https://facebook.com/aslmachinesusa)

# CONTENTS

1. Respiratory Hazard Information...1

## **Chapter I...2**

Safety Instructions...5

Machine Preparation...5

Starting the Engine...5

Stopping the Engine

Maintenance...6

## **Chapter II...7**

Motor Operational Setup...7

LPG Motor Maintenance...12

Troubleshooting Propane Fuel System...16

Wire Schematic...17

## **Chapter III...18**

Equipment Operation Method...18

Belt Changing/Adjusting... 20

Equipment Storage... 22

Machine Warranty Information... 23

PRO 8 BROCHURE... 24

Gearbox Diagram... 25

# RESPIRATORY HAZARD INFORMATION



Wear approved respiratory protection when the machine is operating

## **RESPIRATORY HAZARD INFORMATION:**

*Grinding/cutting/drilling of masonry, concrete, metal and other materials can generate dust, mists and fumes containing chemicals known to cause serious or fatal injury or illness, such as respiratory disease, cancer, birth defects or other reproductive harm. If you are unfamiliar with the risks associated with the particular process and/or material being cut or the composition of the tool being used, review the material safety data sheet and/or consult your employer, the material manufacturer/supplier, governmental agencies such as OSHA, EU-OSHA, and NIOSH and other sources on hazardous materials.*

*California and some other authorities, for instance, have published lists of substances known to cause cancer, reproductive toxicity, or other harmful effects.*

*Control dust, mist and fumes at the source where possible. In this regard use good work practices and follow the recommendations of the manufacturers or suppliers, OSHA, NIOSH, and occupational and trade associations. Water should be used for dust suppression when wet cutting is feasible. When the hazards from inhalation of dust, mists and fumes cannot be eliminated, the operator and any bystanders should always wear a respirator that is approved for the materials being used.*

## **SILICOSIS WARNING INFORMATION:**

*Grinding/cutting/drilling of masonry, concrete, metal and other materials with silica in their composition may give off dust or mists containing crystalline silica. Silica is a basic component of sand, quartz, brick clay, granite and numerous other minerals and rocks. Repeated and/or substantial inhalation of airborne crystalline silica can cause serious or fatal respiratory diseases, including silicosis. When using the equipment with such materials, always follow all dust control and respiratory precautions.*

## **IMPORTANT SAFETY INSTRUCTIONS**

Read and observe all **DANGER, WARNING, and CAUTION** statements included in the owner's manual and attached to the machine. These statements indicate that there is a possibility of death, bodily injury, and damage to the machine or property if these instructions are ignored.

**Operate only in well ventilated areas. Buildings must be provided with:**

- A. A continuous mechanical ventilation that removes the products of combustion to the outdoors of not less than 300 CFM for each 10,000 BTUH or fraction thereof; or
- B. Natural ventilation of not less than 300CFM for each 10,000 BTUH input or a fraction thereof; based on a maximum of one-quarter air exchange per hour for the net building volume.

If you smell LPG gas, stop the unit and check for leaks. Also open windows, don't touch electrical switches, extinguish any open flames. Call your gas supplier if no leaks are found.

Do not adjust the fuel system without the proper analysis equipment.

**DO NOT OPERATE THIS MACHINE IN AN EXPLOSIVE ENVIRONMENT!**

**THIS PROPANE MACHINE IS INTENDED FOR COMMERCIAL USE.**

## **TRANSPORTING THE MACHINE**

**NEVER TRANSPORT WHILE ENGINE IS RUNNING.**

To transport the machine it is necessary to install the transport wheel so the drive plates are not in contact with the floor. In this "balanced" position the equipment can be readily moved from site to site.

### **A. Tilting the Machine**

This is a heavy piece of equipment. Caution should be used in tilting the machine. This can be accomplished safely and easily as follows:

### **1. One man method:**

- a. Standing behind the machine, place one foot on the brace at the base of the propane tank.
- b. Place one hand on the handle and the other on the "T" frame handle support.
- c. While pulling and leaning back, lift the other foot off the floor and extend it directly behind. This will shift the balance and naturally tilt the equipment to transport or full "tilt back" position without undue strain.

### **2. Two man method:**

Two people side by side perform the above procedure simultaneously. This is a safer, more comfortable technique to use until more experience is gained with the equipment.

**Do not use excessive vertical pressure.**

### **B. Position for Maintenance & Cleaning**

To perform certain maintenance & cleaning tasks or to change diamonds, the machine should be placed in the full "tilt back" position. See page 8 for more information about maintenance and cleaning.

## **PREPARATION**

**Flange bearing must be lubricated before every use.** See page 8 for more information about the flange bearing.

**A. Check that the suggested maintenance schedule has been observed.** See page 8-9 for more information about suggested machine and engine maintenance instructions.

*All machines are equipped with a multi-function maintenance meter. The functions include the following: hour meter, service alert and tachometer. (See Engine Maintenance Meter instructions pg. 9).*

## **B. Check the engine oil before every operation.**

*Make sure the machine is level when checking the oil. Always take 2 readings of the dipstick before adding oil. If the oil level is below the full mark, add just enough oil to the engine to bring the oil level up to the full mark. **Never over fill.** Follow the guidelines in your Engine Owners Manual. Check for foreign material on the dipstick.*

## **C. Properly fill and check your LPG tank and all LPG fuel lines for leaks.**

*1. Every tank has been pressure and leak tested. However, every time a tank is filled and/or connected to the machine it should be soap tested. All LPG lines must be pressurized and every inch of line and connections must be sprayed. If you find a leak, make the proper repairs before operating the machine. NOTE: The connection and disconnection of the LPG tank must be done in a well ventilated area with NO source of ignition within 10 feet (3 meters) from the point of connection.*

*2. **Never over fill the LPG tank!** The LPG tank is designed to hold just 20 pounds of propane. Make sure to weigh the tank as it is being filled. The gross weight of a full tank should not exceed 48 pounds. If while operating the machine, you notice frost forming on the LPG lines or the regulator, your tank has been over filled. If you continue to operate the machine in this condition, damage will occur. The excess propane in the tank must be removed before normal operations resume. The bleeding of a propane tank should be done in a safe location outside the building. In some cases the regulator must defrost before restarting the engine.*

## **D. Connecting the high pressure hose to the LPG Tank:**

*Make sure the couplers are in line and screwed together hand tight. If this is not done properly, fuel will not pass through to the regulator. Never complete the connection of the tanks to the machine by using a wrench. Always do it by hand. Listen for the rush of fuel to the lock-out device when you open the tank valve. If you hear this, it indicates a good connection has been made at the tank.*



## **WARNING!**

**NEVER CHANGE OR ALTER THE PROPANE CONTROL EQUIPMENT.  
NEVER TILT THIS MACHINE ON ITS SIDE.**

## **SAFETY**

**Provide and use ear protection during operation.**

**Never let an untrained person operate or perform repairs on the machine. They may hurt themselves, damage the floor or the equipment.**

**Engine speed not to exceed 1700 RPM.**

**DO NOT use machine with a damaged or disintegrated pad to avoid excess vibration.**

Do not allow machine to come into contact with loose tiles or other obstructions on the floor. The abrasives will be turning at approximately 650 Rpm. If objects are hit, they could become dangerous projectiles!

- Extend the handle and tilt machine back until handle rests on floor.
- Install diamonds and remove transport wheel.
- Bring machine back to operating position.
- Fill water tank if wet grinding.

#### I. Preparing to start the engine

1. First - check fuel cylinder for over fill and install cylinder onto machine.
2. Place machine on level surface and check for correct oil level.

#### J. Transporting the machine

1. The tank should be securely fastened.
2. The tank valve must be closed.

### STARTING THE ENGINE

1. Open propane (LPG) tank valve (counter clockwise).
2. Turn the key to start position and move throttle towards fast position.
3. If engine does not start, release the key, then try again.
4. Equipment is supplied with a centrifugal clutch. When engine RPM is lower than 800 RPM clutch will disengage; drivers will stop.
5. Increase throttle to about 75% while walking very slowly.

### A. NEVER TILT BACK MACHINE WHILE ENGINE IS RUNNING

### STOPPING THE ENGINE

*Turn the propane tank valve clockwise to a closed position and turn the key OFF.*

*NOTE: The exhaust system will be very hot and takes several minutes to cool, so keep yourself and all materials clear.*

### MAINTENANCE

#### A. Cleaning the equipment

1. Place machine in "tilt back" position.
2. Rinse the drive unit and drivers.
3. Rinse around splash skirt and body.
4. Return machine to operating position, then start engine and run machine briefly to expel any excess water.

#### B. Storing the machine and tank

1. The engine should be stopped properly and the tank valve closed.
2. Remove the LPG tank from the machine and store the tank in a well ventilated approved area.
3. Store your machine in a safe area: away from enclosed high heat, away from sparks or flames, and away from traffic lanes of heavy equipment.

#### D. Machine & Engine Maintenance

1. Refer to engine manufacturer's Owners Manual and comply completely with the instructions. Change the oil and filter according to the engine Owners Manual.
2. Keep a good service log on each machine with the date, hour meter reading, type(s) of service performed and the name of the person who performed them.
3. Clean the entire unit after each use. When cleaning the unit, check for possible loose nuts and bolts.
4. The foam engine dust filter should be removed and cleaned periodically by shaking out the accumulated dust and rinsing with water.

and a mild detergent. Squeeze out excess water (do not wring out). Allow the filter to air dry before replacing. Failure to the engine filter clean may result in engine overheating.



## **WARNING!**

***Never attempt to adjust the fuel system of a propane engine! if equipped with an emission monitoring or controlling system, never attempt to disconnect or circumvent it. promptly report problems to supervisor.***

***Remember that being safe is a full-time, every day job. follow all information posted on the machine and the LPG tank.***

***Never allow anyone to operate this machine who has not read or cannot understand the given instructions.***

***Do not store or use gasoline or other flammable vapors and liquids in the vicinity of this machine. always store equipment away from heater rooms, boilers, gas-fired water heaters or any other source of open flame. propane is highly flammable. always store LPG tanks (full or empty) outside in a secure, well ventilated area.***

***NO SMOKING, NO SPARKS, NO FLAMES, NEAR UNIT OR LPG TANK.***



## **WARNING!**

***This machine emits CO (carbon monoxide), which is a colorless, odorless, non-irritating gas. symptoms of CO exposure include headache, drowsiness, dizziness and nausea. if you experience any of these symptoms during machine operation, immediately shut off the machine and go outside for fresh air. Have a qualified service technician test the machine for CO emissions before using it again.***

***High exposure to CO may result in vomiting, confusion, collapse, loss of consciousness and muscle weakness. if such symptoms occur, call for emergency medical attention. do not operate this machine or other propane powered equipment until cleared to do so by a physician. excessive exposure to Co can result in death.***

***Never change or alter the propane control components.***

***this machine is factory equipped with engine components and emission controls that maintain harmful exhaust emissions below certified acceptable levels. never tamper, adjust, or remove any factory installed engine components for purposes other than maintenance, repair or replacement.***

***never tilt the equipment on its side for pad, belt or brush replacement. it is designed to tilt back on its rear wheel and handle for maintenance and repair. a second person should aid in lifting and securing equipment for repair.***

***never tilt & transport while engine is running.***

***Keep hands and feet clear of all moving parts.***

**Never try to replace parts or repair equipment with machine running.**

**Turn the gas off at the tank to kill the engine.**

**Remove the LPG tank and store it in an approved area when not in use. a “NO SMOKING” sign should be permanently displayed at the storage area.**

**Always vent an over-full bottle using the tank’s bleed valve, out of doors away from all closed places and away from any fire or flame producing device. Vent until the white vapor turns clear.**

**This machine is intended for use with vapor withdraw propane cylinders only. NEVER use a liquid withdraw propane cylinder with this equipment. DO NOT over fill the cylinder. if the regulator or regulator connection freezes, stop the machine and take the cylinder outdoors. inspect cylinder and purge the cylinder using the bleeder valve if necessary.**

**Keep all objects clear of the exhaust system during and after operation.**

**Do not leave this machine unattended while the engine is running.**



## **WARNING!**

**Do not operate equipment in one location for more than a few seconds. damage to floor surface can occur.**

**Always store equipment away from possible damage by falling objects in warehouse-type areas. always store LPG tanks outside in a secure, well-ventilated area.**

**The muffler and engine become hot enough during operation to cause severe burns. these parts remain hot for a long time after the machine has been shut off. do not touch**

**these parts until they have cooled.**

**Safety goggles, safety shoes and safety clothing are recommended while operating the machine.**

**Continuous exposure to high noise levels can cause hearing loss. Hearing protection must be worn while the machine is in operation. the operational weighted sound level of this machine is less than 89dB(a). all noise area precautions must be followed.**

**Prolonged exposure to machine vibration may cause tingling or numbness in the fingers and hands. Use of gloves and limits to operator vibration exposure are recommended to prevent such symptoms. the operational hand/arm vibration level of this machine is less than 2.5m/s<sup>2</sup>.**

**When LPG tank is attached to the machine and not running, the operator should not leave the machine unattended except for short periods of time such as rest stops, washroom or meal stops.**

**The operator must completely understand all instructions, warning and operating procedures before using this machine.**

**This machine must be maintained in accordance with this manual’s recommended maintenance instructions and the engine manufacturer’s recommended maintenance procedures. failure to do so may cause damage to the machine, equipment, furniture, buildings or personal injury. a maintenance record should be kept indicating date of service, hours on engine, and work done.**



## Operational Set Up

### Adding Engine Oil



**Important – Engines are shipped dry. Must add oil prior to operation.**

- The engine(s) are tested and set at the factory. Then the oil is drained for shipment.
- See Figure-1 for oil viscosity.

#### Oil Recommendations

We recommend the use of Briggs & Stratton Warranty Certified oils for best performance. Other high-quality detergent oils are acceptable if classified for service SF, SG, SH, SJ or higher. Do not use special additives.

Outdoor temperatures determine the proper oil viscosity for the engine. Use the chart to select the best viscosity for the outdoor temperature range expected.

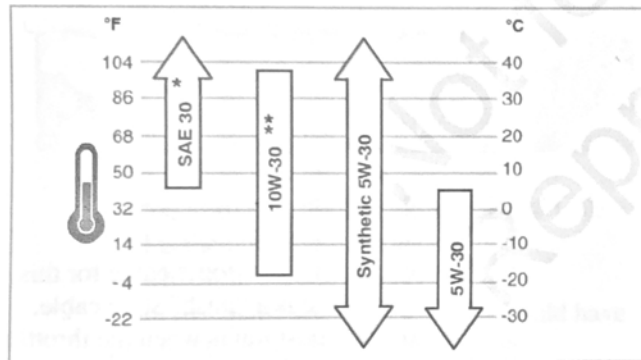

\* Below 40°F (4°C) the use of SAE 30 will result in hard starting.

\*\* Above 80°F (27°C) the use of 10W-30 may cause increased oil consumption. Check oil level more frequently.

Figure - 1

- PPS recommends the use of Synthetic 5W-30. Better for engine brake in period and longer duration between oil changes.

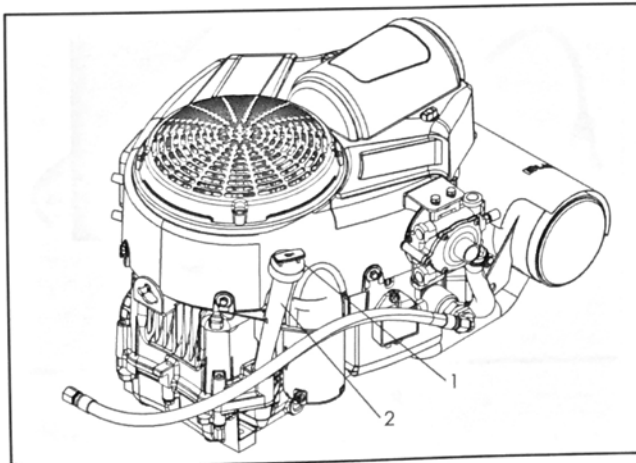

Figure - 2

- Remove the (1) filler cap/dipstick and slowly add approximately 80% of the specified oil to the (2) engine oil fill tube to bring the level of oil to the full mark on the (1) filler cap/dipstick (Figure-2).

### Installing the Propane Tank

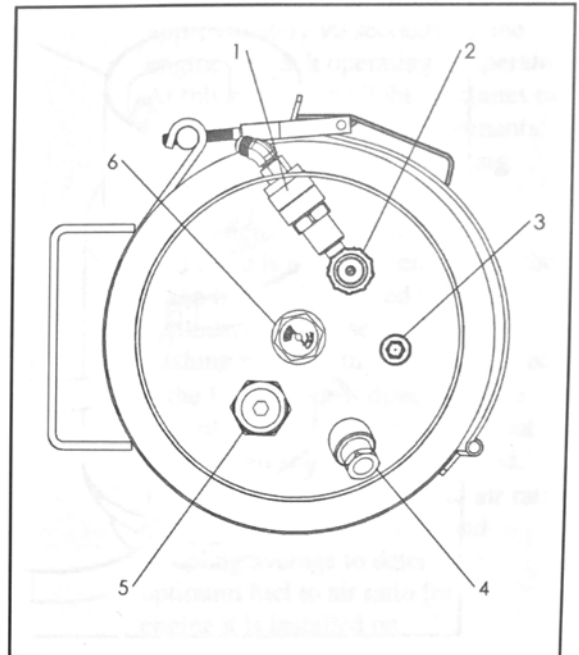

Figure - 3

- The equipment operators need to familiarize themselves with the connections, valves and gauges on the propane tanks.
- Figure -3 identifies the connections, valves and gauges as the following;
  1. Quick Disconnect Right Hand ACME Thread Valve.
  2. Vapor Tank Service Valve.
  3. Bleeder Valve (Only to be used by trained and qualified personnel. The bleeder valve is used during the propane fill process).
  4. Safety – Pressure Relief Valve
  5. Fill Valve (Only to be used by trained and qualified personnel).
  6. Propane – Fuel Gauge

## Operational Set Up



**Important – The Briggs & Stratton 810cc Propane Power System Engine must use special vapor tanks that are specifically designed for vapor run small engine application for concrete equipment.**

- The propane tank is sold separately and can be purchased by Propane Power Systems or Manchester Tank & Equipment.

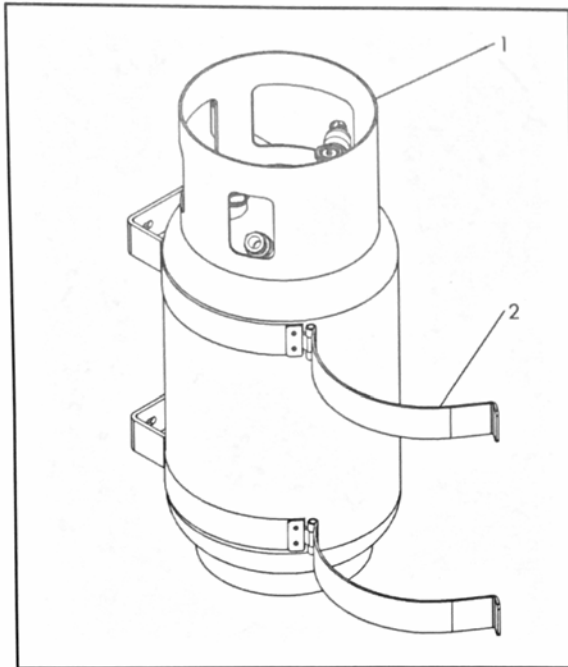

Figure - 4

- Install the (2) propane tank straps and then place the (1) propane tank into the tank straps as see in Figure -4.
- Connect the (1) fuel hose to the (2) quick disconnect (Figure -5).
- Latch the tank strap brackets and ensure the tank is securely fastened to the equipment.
- Slowly open the fuel valve counter-clockwise to equalize the pressure. Check for leaks.
- If leaks are present, turn off propane tank and tighten or replace fittings.
- Leave the fuel valve off when finished.

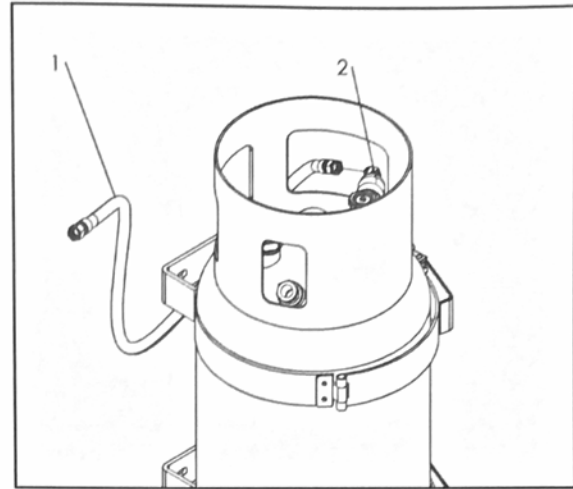

Figure - 5

### Throttle Cable Installation

- The recommended throttle cable for this engine package is a “push” style cable.
- The low idle position is when the throttle handle is in the down position. Low idle = 100-800 RPM (Figure -6).
- To increase RPM, push the throttle handle forward. Max RPM =1600-1700 RPM (Figure -6).

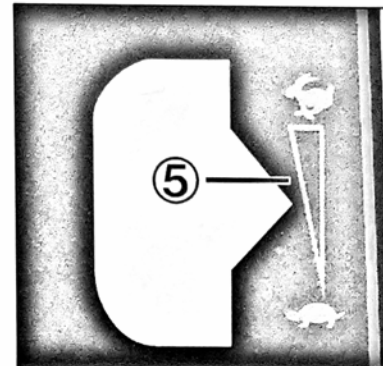

Figure - 6

## Operational Set Up

- The throttle cable end should be attached to the engine throttle plate as seen in Figure -7.

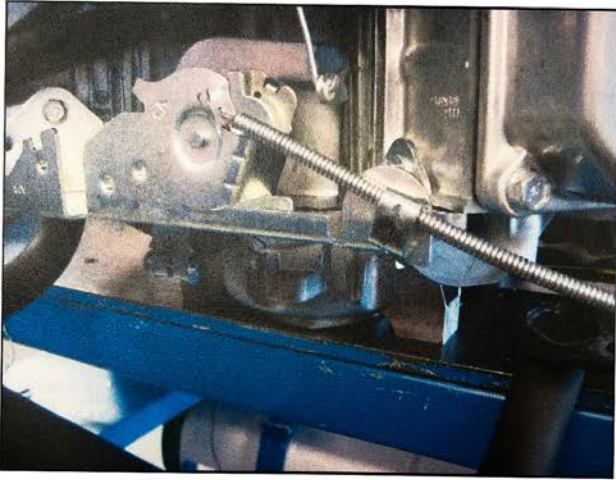

Figure - 7

- A “pull” style throttle cable is also available and is the opposite throttle control of the “push” style described above.
- With the “pull” style, the low idle would have the throttle handle in the up position.
- Pull the throttle handle down for high speed (RPM).

## **Emission Data Analyzer Installation**

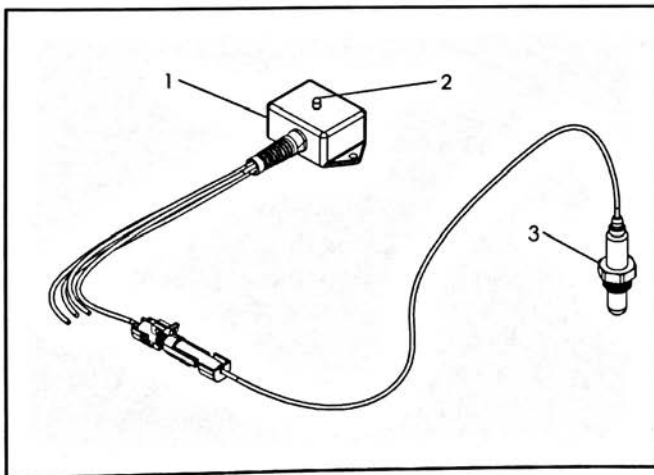

Figure - 8

- In Figure-8, (1) is the *Emission Data Analyzer Model*, (2) is the *indicator light* and (3) is the *O2 sensor*.

- The operation of the Emission Data Analyzer (EDA) is as follows;
  - The startup hold period begins when the ignition switch is activated. During this 7-8 second period the red light glows while the system is calibrating itself.
  - When all systems have passed the red light turns to green indicating engine is ready to start.
  - After the engine is started, it takes approximately 90 seconds for the engine to reach operating temperature. At this point if the light continues to glow green the engine adjustments and components are functioning properly.
  - If the engine is not adjusted properly or if there is a component failure the green light will turn red for 60 seconds. After 60 seconds, the flashing red light turns to a solid red.
  - If the EDA is wired directly to the shut-off valve, the engine will shut down when solid red is displayed.
  - The EDA samples the fuel to air ratio every second, using a 5 second sampling average to determine optimum fuel to air ratio for the engine it is installed on.

## Engine conditions that require a red alert / pre-alert

- Clogged or restricted air filter.
- Regulator not adjusted correctly.
- Vapor regulator exposed to liquid ingestion, freeze up requires regulator re-adjustment.
- Overfilled cylinder or the wrong cylinder for a vapor application.
- Damaged regulator from liquid ingestion, no longer adjustable, stretched diaphragms.
- Damaged, worn or improperly adjusted spark plugs.
- Low ignition voltage or no ignition on one or more engine cylinders.
- Low compression on one or more of the engine cylinders.

## Operational Set Up

### Emission Data Analyzer Installation

- The engine package includes a (1) *Three Way Catalytic Muffler*. Unbolt the (2) *M18 threaded Plug* from the Cat/Muffler as seen in Figure -9.

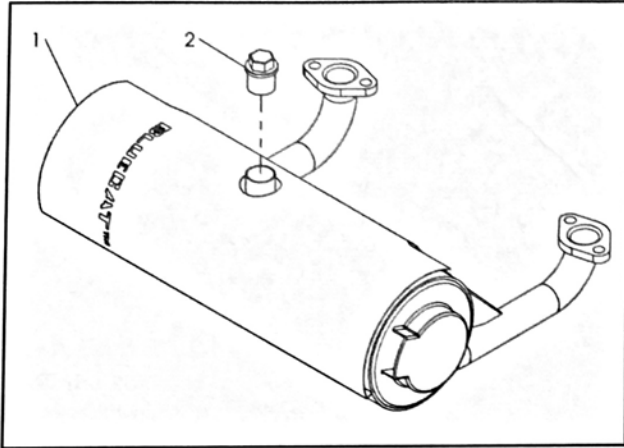

Figure - 9

- Install the (2) *O2 sensor* into the open port on the (1) *Three Way Catalytic Muffler*, as seen in Figure-10.

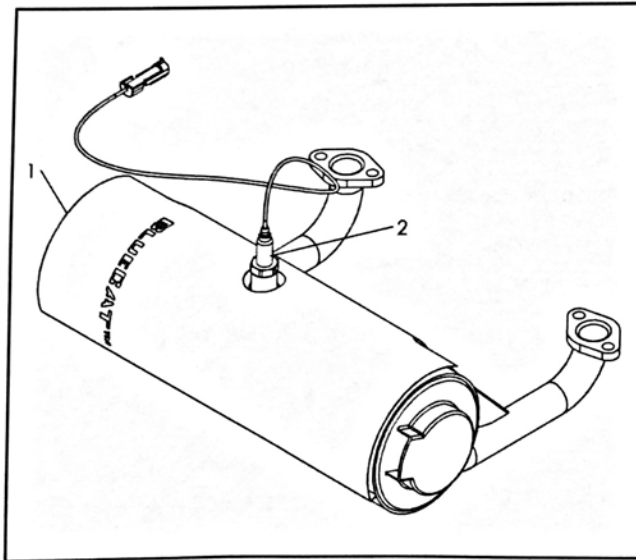

Figure - 10

- Install the Three Way Catalytic Muffler onto the exhaust manifold on the 810 cc

Briggs & Stratton Propane Powered 810cc Engine.



**Danger – Use extreme caution when handling propane. Propane is flammable and explosive and can cause personal injury if not handled properly.**

**No smoking or open flame around propane.**

**Fill the propane tank outdoors in a well-ventilated area.**

**Note: The regulator has been preset to the emissions standards listed on page 4 under Specifications. Only use the below Operational Set Up for fine tuning your engine.**

Note, there are no adjustments requirements for the carburetor:

### Setting the Regulator

- Setting the fuel system is relatively easy.
- Tools required;
  - Standard and a small flat head screw driver
  - Pressure gauge that reads 0-15 psi

### Setting Fuel Pressure

- Position the equipment in a well ventilated area on a flat surface
- On the flat side of the regulator is a round tower that protrudes out about  $\frac{3}{4}$ ". Inside the tower is a (1) *large adjustment screw* that sets pressure for the regulator and to the right side of the regulator is a (2) *Schrader valve* for measuring pressure (Figure-11).
- Remove the Schrader valve cover and install the 0-15 psi pressure gauge.
- Double check the high pressure and low pressure hoses are all tightly fastened to the appropriate fittings.

## Operational Set Up

- Turn on the propane cylinder valve to pressurize the system.
- First test the solenoid shut-off valve to insure propane pressure to the regulator by turning the ignition key to the on position without turning the engine over. You should be able to hear the solenoid click along with having 3-4 psi on the test gauge.

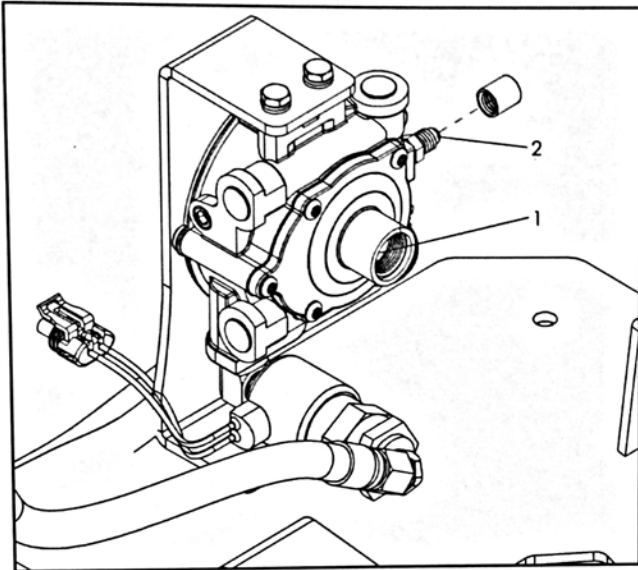

Figure - 11

- If pressure is present on the test gauge, proceed with starting the engine. Note, setting the regulator pressure requires the engine to run at low RPM (Low Idle).
- If the engine will not turn over or you show 0 psi on the test gauge, turn the fuel flow small screw clockwise two turns to open flow to the regulator. Repeat this step until the engine starts. Note, always keep the throttle at low idle when adjusting the propane regulator. Advancing the throttle will usually end up flooding the engine.
- Once the engine is running, set the fuel pressure for 4.0 psi by turning the large adjustment screw clockwise to increase and counter clockwise to decrease pressure.

## **Setting Fuel Flow**

- Once the fuel pressure is set at low idle, it is time to set the fuel flow.
- To the right of the pressure adjustment screw is the fuel flow (3) adjustment screw that is marked as "idle" (Figure-12).
- With the engine running at full RPM, use the small screw driver and turn the idle screw clockwise to increase fuel flow (richer) and counter

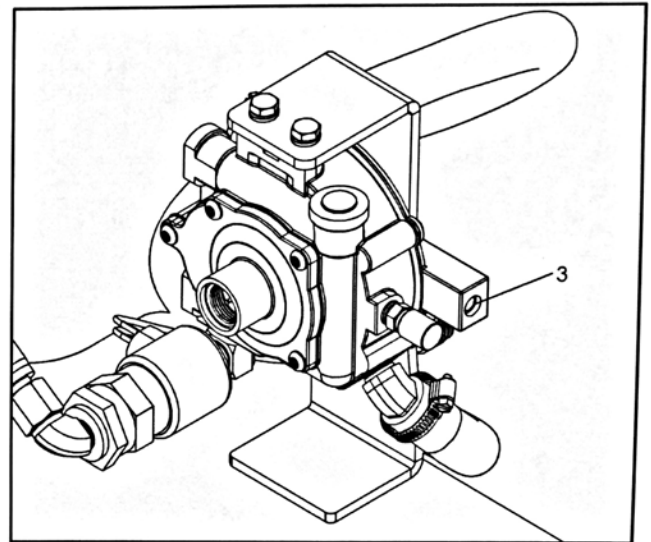

Figure - 12

clockwise to lower the fuel flow (leaner). The objective is to get the best or highest rpm on the engine with the smoothest performance.

## **Fuel System Final Set Up**

- The final step, is to let the engine warm up to operating temperature and recheck the regulator pressure at low idle. If the pressure needs to be adjusted the fuel flow will also require adjusting.

## Maintenance



**Inspection and maintenance should be performed only when the engine is off and all fluids are cold. Stop the engine and remove the ignition key.**

Daily Checks	Check Engine Oil Level
	Check the Propane System
First 5 Hrs	Change Oil
Every 50 Hrs	Clean or Change Air Filter
	Change Engine Oil
Every 100 Hrs	Change Engine Oil
	Replace the Air Filter
Every 200 Hrs	Check, clean and re-gap the spark plug
Every 750 Hrs	Replace Spark Plug

### Replacing the Propane Tank



**Danger – Use extreme caution when handling propane. Propane is flammable and explosive and can cause personal injury if not handled properly.**

**No smoking or open flame around propane.**

- Shut off the machine on level ground.
- With the engine running, close the fuel valve on the propane tank.
- Run the engine until it stops. This will insure that all vapors purge from the fuel hose.
- Turn the key to the off position and remove.
- Carefully disconnect the propane fuel hose.
- Unlatch the tank straps and remove the tank.
- Inspect the filled tank valve, o-ring and fitting openings for dirt, debris or damage.
- Ensure that the replacement tank type and size match the tank specification decal.

- Latch the tank strap brackets and ensure that the tank is securely fastened to the equipment.
- Carefully connect the fuel hose, ensure that the hose is not kinked.
- Slowly open the fuel valve counter-clockwise to equalize the pressure in the tank

### Air Filter Service

Clean Air Filter = Every 50 hours

Replace Air Filter = Every 100 hours

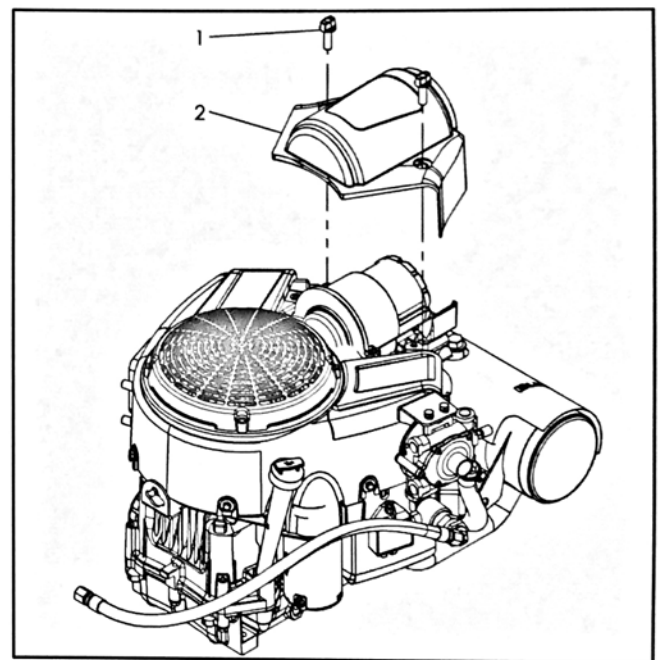

Figure - 13



**Important – Do not use pressurized air or solvents to clean the air filter. Pressurized air can damage the filter and solvents will dissolve the filter.**

1. Loosen the two air filter cover (1) fasteners and remove the (2) air filter cover (Figure -13).

## Maintenance

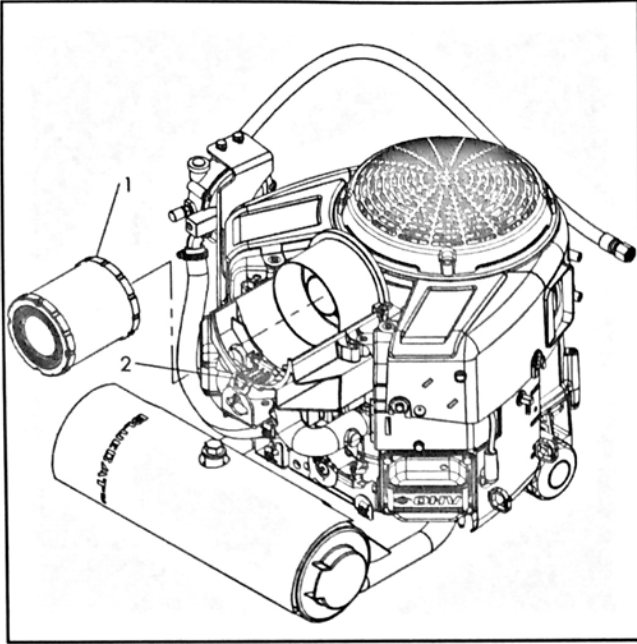

Figure - 14

2. With the air filter removed open the filter (2) latch and remove the (1) filter (Figure-14).
3. To loosen debris, gently tap the filter on a hard surface. If the filter is excessively dirty, replace with a new filter.
4. Install the (1) filter and close the (2) latch (Figure-14).
5. Install the (2) air filter cover and secure the two (1) fasteners (Figure-13).

### Battery Service



**Caution – Battery posts, terminals, and related accessories contain lead and lead compounds. Wash hands after handling.**

**Caution – Wear eye protection when servicing the battery.**

**Caution – Untrained/Unauthorized persons should never attempt to service or recharge the battery.**

**Caution – Dispose of used batteries in accordance with local regulations.**

Clean Battery = 200 hours

Briggs & Stratton recommended battery specifications;

Battery Type – GT-XHD

Cranking Amps @ 0 F – 350 amps

Reserve Capacity @ 80 F – 34 mins

Approx. Wt. Wet – 19 lbs.

1. Disconnect the battery terminals, negative (black) first and then the positive (red).
2. Clean off any corrosion from the battery and battery terminals with a solution of water and baking soda.
3. If the battery has heavy corrosion, remove and clean with solution.
4. Allow battery and terminals to dry and reinstall.

# Maintenance

## Engine Oil Service

Replace Engine Oil = After first 5 hours of operation. Every 100 hours thereafter

Replace Oil Filter = Every 100 hours

1. Make sure that the equipment is on a flat and level surface with the engine off.

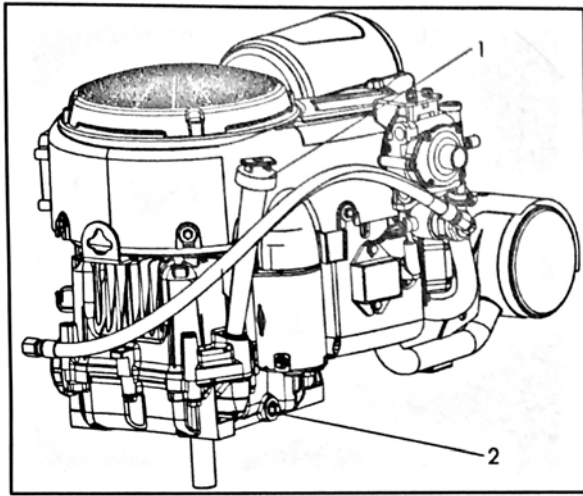

Figure - 15

2. Remove the (1) dipstick (Figure-15)
3. Locate the (2) drain plug and place a drain pan under the plug to capture the used oil. Remove the drain plug and allow the oil to drain into the pan. Once the oil is done draining, install the (1) drain plug (Figure 15).
4. Clean the area on the crankcase.
5. Remove the (1) oil filter and apply a light coat of oil to the new filter gasket (Figure-16).
6. Screw the new (1) oil filter on by hand until the gasket mates with the filter adapter, then tighten 1/2-3/4 turn more.
7. Add oil to the crankcase using the Engine Oil Level & Adding Oil instructions located in the operations section of this manual, pg. 9.

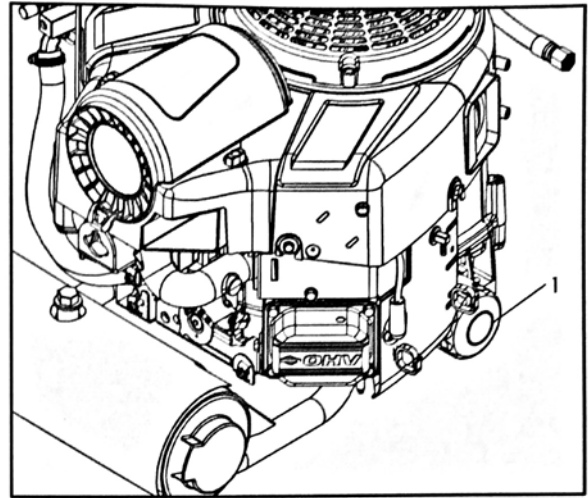

Figure - 16

## Fuel System Service

Check Propane Tank & components = Daily

Check Propane hoses and regulator = 40hrs



**Important – Never check for leaks using an open flame.**

**Never use bare hands when checking for leaks. Escaping propane vapor and liquid freezes skin on contact.**

## Daily Inspection

- Visually inspect the tank, hose and fitting and be alert to a foul odor coming from the tank. Do not use the propane system if the hoses are abraded, damaged, kinked or flattened.
- Ensure the propane tank is free of dents or damage. If the tank shows signs of damage, replace it immediately.
- Check the valve fitting openings for dirt or debris.
- Slowly open the valve all the way and listen for a continuous hiss from the regulator, which may indicate a leak.
- Propane has a rotten egg smell added to it to help detect a gas leak.



## Maintenance

- Ensure that the tank is securely mounted to the equipment. If the tank is loose, the hose or fittings may leak.

### Weekly Inspection

- Check the propane hoses, regulator and connections for damage or deterioration.
- Check the propane hoses, regulator and connection for leaks at all joints using the leak detection method listed below.

### Leak Detection Method Instructions

- Apply an approved leak detector solution, obtained from a trained and qualified propane distributor, or a thick non-ammonia soapy water solution (1:1 mixture of 1 part non-ammonia soap and 1 part of water).
- Using a small brush or spray bottle, apply the solution around all fitting of the propane tank, regulator and connections.
- Slowly open the gas valve a half-turn.
  - If you detect bubbles, the joint or fitting has a leak. Shut off the valve, tighten the leaking connection and slowly open the valve again to half-turn. If leak persists, replace fitting.

### Spark Plug Service

Check, clean and re-gap = 200 hours

Replace Spark Plugs = 750 hours

Spark Plug Gap = .030 in

Spark Plug Torque = 180 lb-in

- Shut off the engine, remove the key, and allow the engine to cool.
- Locate the (1) spark plugs as seen in Figure-17. Note, the 2<sup>nd</sup> spark plug is same location opposite end.
- Remove the spark plug boot and remove the spark plug.

- Check the spark plug gap between the center and ground electrodes.

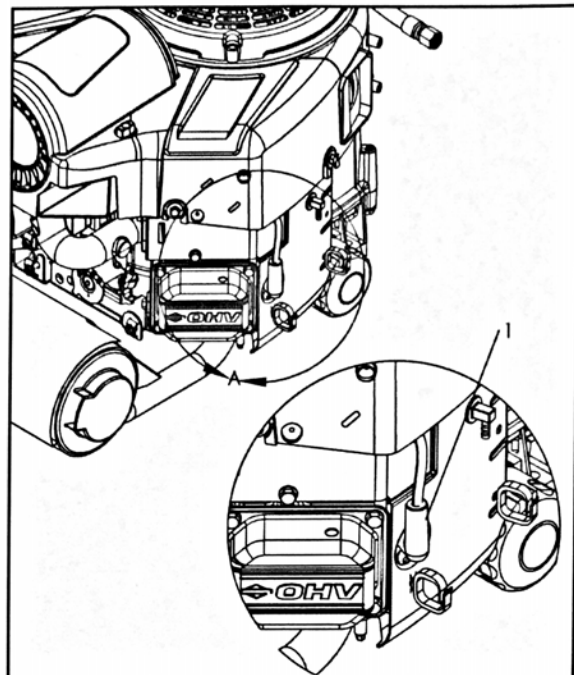

Figure - 17

- If necessary, reset the gap to .030 inches.
- Install and tighten the spark plug to 180 lb-in.

## Trouble Shooting Propane Fuel Systems



**Danger – Use extreme caution when handling propane. Propane is flammable and explosive and can cause personal injury if not handled properly.**

**No smoking or open flame around propane.**

**Fill the propane tank outdoors in a well-ventilated area.**

Use the following steps when the engine is not igniting or irregular idling:

### **Propane Cylinder**

- Check the propane cylinder valve to see if it is open. Open if closed and restart the engine.
- Check the propane cylinder fuel gauge. Refill if empty.

### **High & Low Pressure Hoses**

- Check both ends of the high pressure fuel line between the propane cylinder and regulator solenoid shut-off valve. Make sure both ends are threaded tight on the brass fittings.
- Do the same with the low pressure hose to make sure that both hose clamps on the end of the hose are tight.

### **Solenoid Shut-Off Valve**

- Check the solenoid shut-off valve to see if the valve is in fact opening when the ignition key is turned. There are two ways to determine if the solenoid valve is opening.
  - One, the sound and or vibration method. Typically, you can hear when the coil energizes the solenoid plunger valve. The plunger makes a click noise when energized. The energizing of the

solenoid plunger valve also makes the solenoid housing vibrate. Place your hand over the solenoid valve and have a second operator turn the ignition key.

- Two, check to see if there is pressure on the regulator valve when the solenoid valve is on.
- When it is confirmed that the solenoid shut-off valve is not energizing check to make sure that the ground wire hasn't been nicked or cut. Check to make sure that the grounding bolt, located on the engine chassis, is tight and making contact with the grounding wire eyelet. Also check the positive wiring for nicks or cuts. Along with checking the connector on both ends of the wire harness.
- If the solenoid shut-off valve is opening check the regulator.

### **Regulator**

- Open the Schrader valve cap and install a pressure gauge with a range of 0-15 psi.
- Turn the key to the on position without turning the engine over and check the pressure at the regulator's Schrader valve. The pressure should be between 3 ½ - 4 psi, adjust regulator if not in the pressure range. Note, if there is pressure at the regulator the engine is getting fuel. If no pressure is present check the trouble-shooting points above. Once complete and still no pressure, proceed with setting the fuel flow on the regulator.
- The other setting control is the fuel flow also known as the idler. If you still show no pressure on the psi gauge, turn the idler screw clockwise to increase fuel flow. If still not pressure is present at the gauge after turning the adjustment screw to the complete open position, then the regulator is not working and will need to be replaced.
- If the engine will not start and fuel is getting thru the regulator, then you most likely have a problem that is not fuel related.

# Wire Schematic

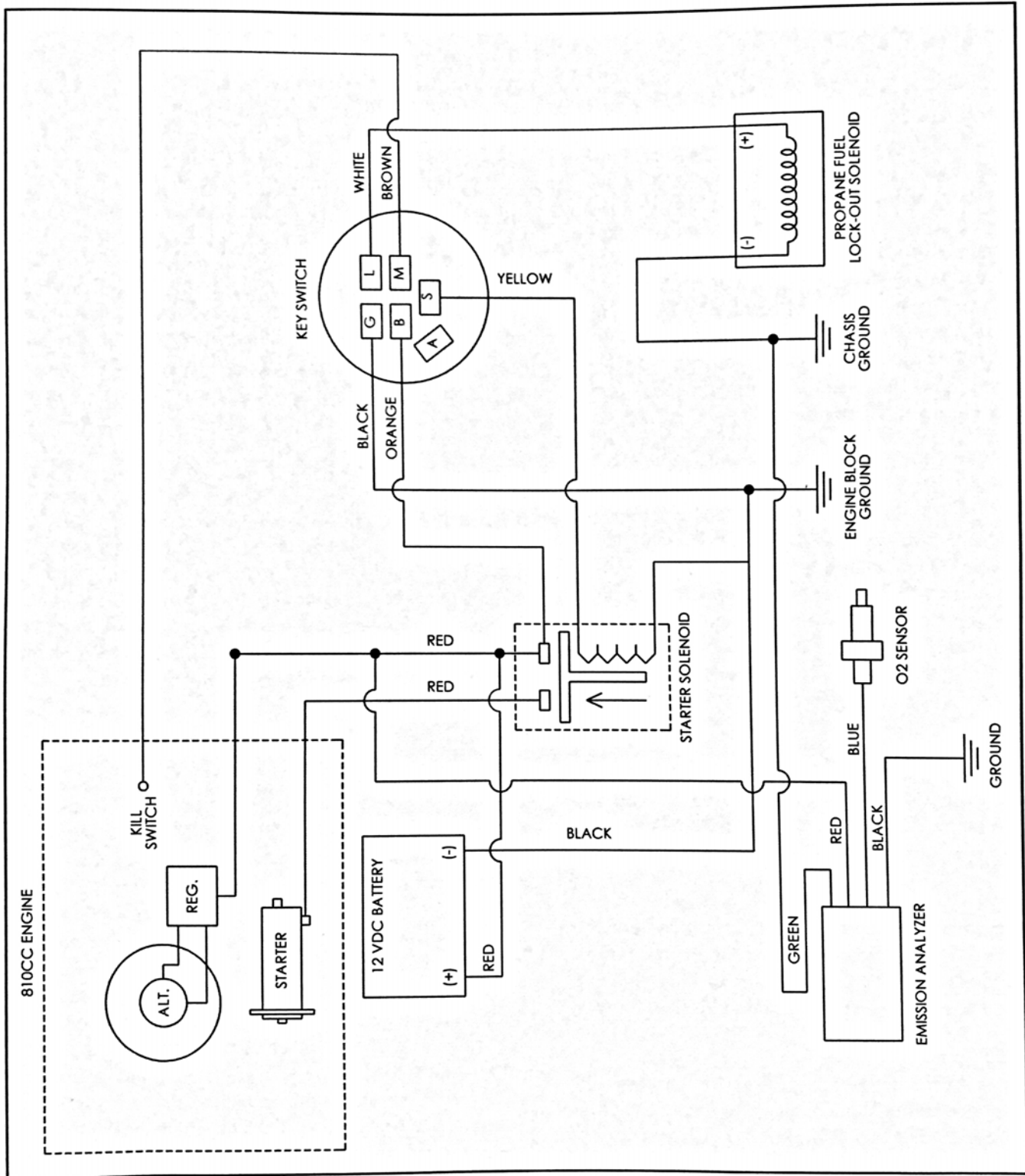

# Equipment Operation Method

[1]: Prior to starting machine, check to ensure the throttle stage is set to the **STOP** position.

[2]: First adjust the handle in the line-style, and then hold the handle and with one foot stepping on the step bar and press downwardly; after the equipment is fixed on the ground, check whether the external parts are complete, whether there is any wrong installation of tools, neglected installation and loose parts. Immediately solve the problem if finding these issues.

[3]: After checking, press the equipment down until the chassis touch the ground, and lay it flat.

[4]: Apply grinding tooling onto the equipment, and the basic steps on the following page:

- (1) As shown in Figure 1, the equipment chassis is loaded with a polishing plate
- (2) Place desired tooling on machine utilizing the magnetic plates.
- (3) After loading, check whether the parts are complete once again.
- (4) Install or tighten the handle, clockwise rotate the black rotary handle to the tightest state. Rotate in the reverse direction when dismantling the handle as shown in Figure 3.

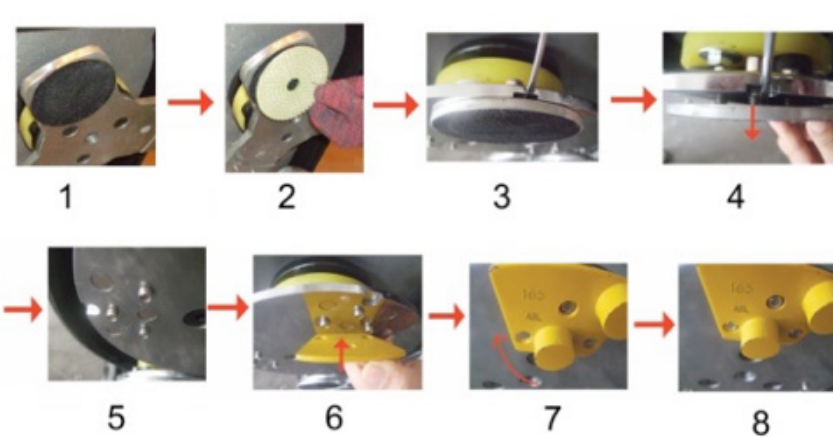

**FIGURE 1**



**FIGURE 2**

[5]: Always ensure prior to starting that the machine contains the proper amount of motor oil by checking the oil level as shown in figure #3 Below by the red arrow. Also check the propane to ensure flawless operation.



**FIGURE 3**



**FIGURE 4**

[6]: Ensure throttle is set to the **STOP** position as shown in figure 4 above.

[7]: If wet cutting, and optional water tank is installed, turn the water on using the water valve as shown in figure 5 Below.

[8]: If dry cutting, ensure vacuum is properly connected as shown in figure 6 below.



**FIGURE 5**



**FIGURE 6**

[9]: Turn on the propane tank and start the motor by turning and holding the key to the start position until the motor starts as shown in figure 7 below.



**FIGURE 7**

[10]: Slowly increase the throttle speed until desired RPM setting is achieved.

# Changing and Adjusting the Machine Belt

[1]: The following is an instructional information sheet designed to instruct operators on how to change their machine belts.

[2]: Begin by loosening the four motor mount bolts.



[3]: Loosen and remove the three heat shield bolts and the motor exhaust bolts in order to remove the heat shield. Set heat shield and bolts in a safe place.

[4]: Loosen the belt tension screw located at the rear of the machine. After loosening the tension screw, slide the motor to the rear of the machine.

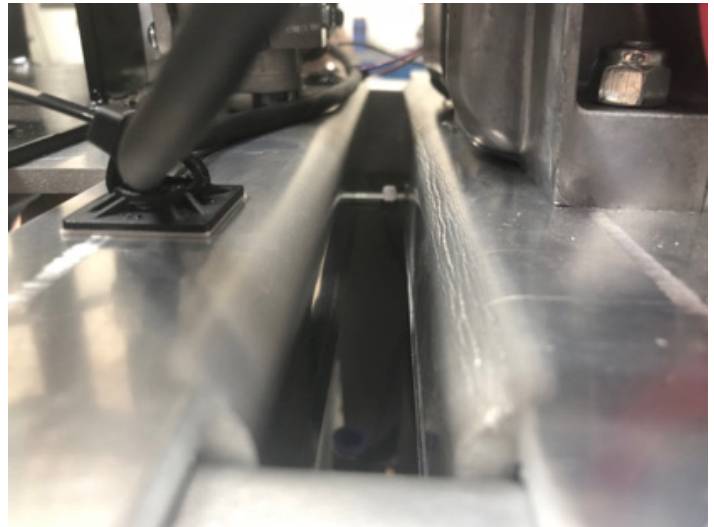

[5]: Remove belt by pulling belt off of pulley. Replace belt and slide motor back forward by pulling. Tighten the belt tension screw and check tension by hand. The amount of play should be roughly  $\frac{1}{4}$ ". Replace Heat Shield and tighten all motor mount bolts, heat shield bolts, and motor exhaust bolts.



# Equipment Storage after Use

[1]: Place the handle into the vertical position, turn propane off, disconnect vacuum and store in a dry place.

[2]: Dismount the small grinding head from the machine, clean and dry them.

[3]: Use a half-dry clean rag to clean the machine. Pay attention to cleaning the machine surface after being used in wet environment. Ensure to not power wash near seals or near electrical components.

[4]: Check whether the machine and the accessories are in good condition, and make necessary repair and maintenance before storage.

[5]: Keep the machine in the clean and dry place, and when storing, place the handset in the vertical position and fasten tightly.



## Machine Warranty Information

The quality of this product is warranted to be free from defects in both materials and workmanship. The machine warranty is as follows.

Part	
Engine	2 Year Warranty
Fuel System	2 Year Warranty
LP Tank (On select models)	1 Year Warranty
Machine Body Parts	2 Year Warranty
Battery	1 Year Warranty

Note: this warranty does not cover certain wearable parts such as belts and engine tune up parts.

LP Engines are warranted by the engine manufacturer for the term specified by the engine manufacturer.

ASL Machines USA promises, at their discretion, to repair or replace any product or part(s) which examination proves to be defective in either workmanship or materials used. ASL Machines USA must be notified directly within the warranty period.

This warranty does not cover damage, or failure caused by abuse, misuse, neglect, disassembly, alteration, unauthorized modification, lack of proper maintenance, theft, or any damage by freight carriers. This warranty applies to parts and labor only, and does not cover any incidental or consequential damages.

This warranty is non-transferable.  
ASL Machines USA

# PRO 8 25" FLOOR GRINDER

The **ASL PRO 8** is an impressive **25-inch** floor grinding machine that has an aluminum alloy gearbox and planetary gear driver.

This machine is **propane powered** allowing the operator to work anywhere without worrying about power cords or having insufficient power. With the magnetic plates, changing tooling is a simple task.

With a folding handle and split body design this machine can be moved and carried easily. The integrated vacuum port allows the machine to **grind and polish wet or dry**.



**FINANCING AVAILABLE**  
**2 YEAR WARRANTY**

Model	PRO 8
Power	22 HP Propane
Motor Options	Briggs & Stratton or Kawasaki
Disc Speed	300 - 1800 RPM
Grinding Width	25"
Disc Diameter	10" X 3
Propane Tank	20 lbs
Water Tank	8 Gallons
Weight	625 lbs
Head Pressure	380 lbs

3 Magnetic Plates



Control Panel

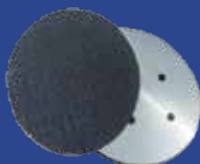

Resin Holders



With or Without Water Tank



Clean Air Emissions Sensor

# GEARBOX DIAGRAM:

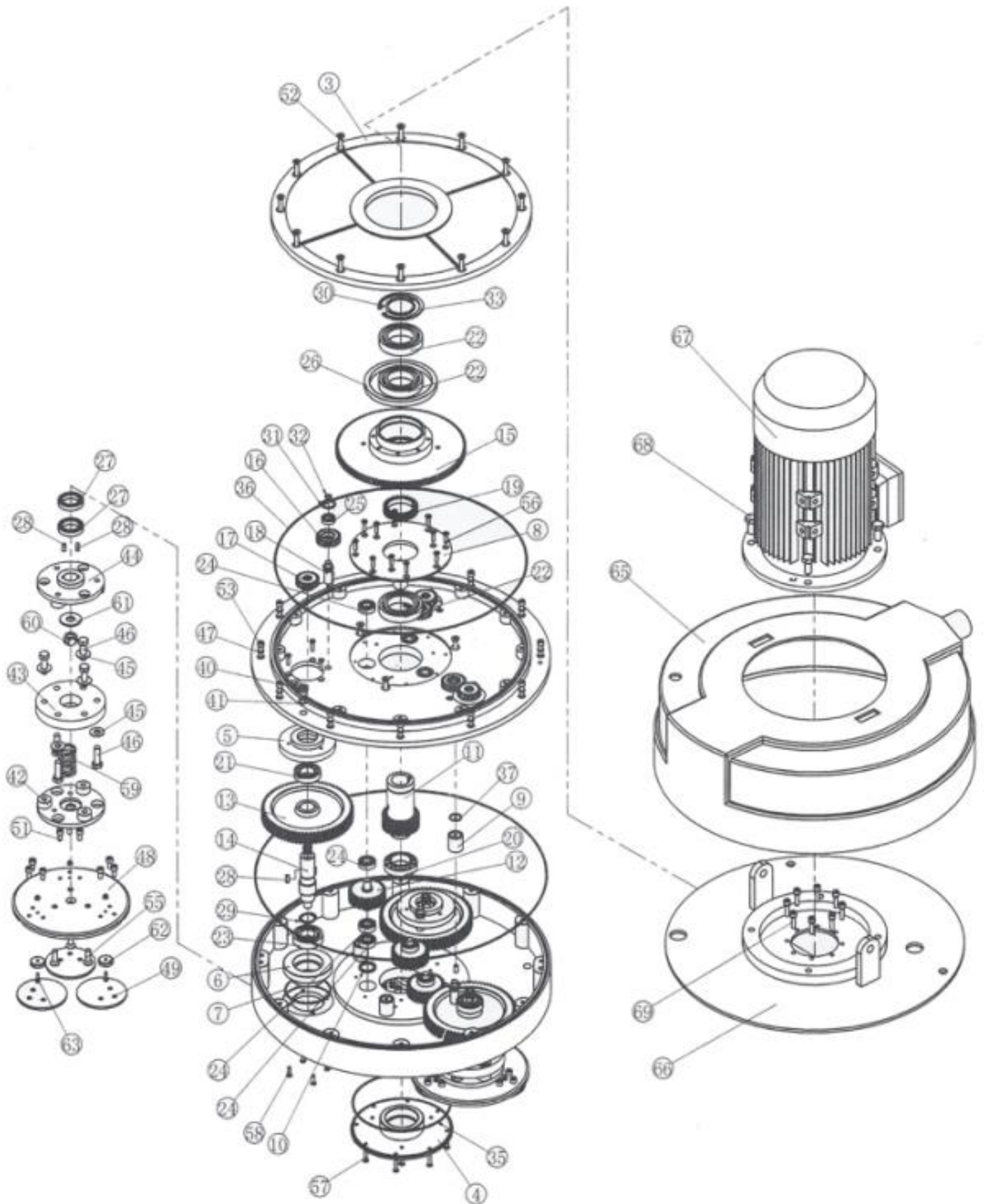



9328 Wheatlands Rd Suite A Santee, CA 92071  
(866) 275 0446 • [info@ASLMachinesUSA.com](mailto:info@ASLMachinesUSA.com)  
[ASLMachinesUSA.com](http://ASLMachinesUSA.com) • [facebook.com/aslmachinesusa](https://facebook.com/aslmachinesusa)