



STENNER

Metering Pumps
Manufactured Since 1957

SVP Series

INSTALLATION AND
MAINTENANCE MANUAL

Table of Contents

Warranty and Service Policy	3
Safety Information	4-5
Pump Identification	6-7
Outputs	8
Materials of Construction	9
Accessory Checklist	10
Installation	11-20
Troubleshooting	21-23
Separating and Reconnecting Subassemblies	24
Tube Replacement	25-29
Cleaning the Point of Injection	30-32
Motor – exploded view and parts	33
Pump Head – exploded view and parts	34-36
Pump Tubes	37
Check Valves	38
For Your Records	39

SVP06

Warranty and Service Policy

Damaged or Lost Shipments

UPS and prepaid truck shipments: Check your order immediately upon arrival. All damage must be noted on the delivery receipt. Call Stenner Customer Service at 800.683.2378 for all shortages and damages within seven (7) days of receipt.

Returns

Stenner offers a 30-day return policy on factory direct purchases. Except as otherwise provided, no material will be accepted for return after 30 days from purchase. To return merchandise at any time, call Stenner at 800.683.2378 for a Returned Goods Authorization (RGA) number. A 15% re-stocking fee will be applied. Include a copy of your invoice or packing slip with your return.

Limited Warranty

Stenner Pump Company will for a period of one (1) year from the date of purchase (proof of purchase required) repair or replace – at our option – all defective parts. Stenner Pump Company is not responsible for any removal or installation costs. Pump tube assemblies and

rubber components are considered perishable and are not covered in this warranty. Pump tube will be replaced each time a pump is in for service, unless otherwise specified. The cost of the pump tube replacement will be the responsibility of the customer. Stenner Pump Company will incur shipping costs for warranty products shipped from our factory in Jacksonville, Florida. Any tampering with major components, chemical damage, faulty wiring, weather conditions, water damage, power surges, or products not used with reasonable care and maintained in accordance with the instructions will void the warranty. Stenner Pump Company limits its liability solely to the cost of the original product. We make no other warranty expressed or implied.

Disclaimer

The information contained in this manual is not intended for specific application purposes. Stenner Pump Company reserves the right to make changes to prices, products, and specifications at any time without prior notice.

Safety Information

 **WARNING** Warns about hazards that **CAN** cause death, serious personal injury, or property damage if ignored.

 **ELECTRIC SHOCK HAZARD**

 **WARNING** **ELECTRIC SHOCK HAZARD:**
Pump supplied with grounding power cord and attached plug. To reduce risk of electrical shock, connect only to a properly grounded, grounding type receptacle.

 **AVERTISSEMENT** **RISQUE DE CHOC ELECTRIQUE:**
Cette pompe est équipée d'une fiche de mise à terre. Pour réduire le risque de choc électrique, s'assurer que la fiche est bien raccordée à une prise de courant avec une connexion de mise à terre.

 **DO NOT** alter the power cord or plug end.

 **DO NOT** use receptacle adapters.

 **DO NOT** use pump with a damaged or altered power cord or plug. Contact the factory or an authorized service facility for repair.

 **WARNING** **HAZARDOUS VOLTAGE:**
DISCONNECT power cord before removing motor cover for service. **Electrical service by trained personnel only.**

 **WARNING** **EXPLOSION HAZARD:**
This pump **IS NOT** explosion proof. **DO NOT** install or operate in an explosive environment.

 **WARNING** **RISK OF FIRE HAZARD:**
DO NOT install or operate on any flammable surface.

 **WARNING** **RISK OF CHEMICAL EXPOSURE:**
Potential for chemical burns, fire, explosion, personal injury, or property damage. To reduce risk of exposure, the use of proper personal protective equipment is mandatory.

Safety Information continued

⚠ CAUTION Warns about hazards that **WILL** or **CAN** cause minor personal injury or property damage if ignored.

❗ NOTICE: Indicates special instructions or general mandatory action.

❗ NOTICE: This metering pump and its components have been tested for use with the following chemicals: Sodium Hypochlorite (10-15%), Muriatic Acid (20-22 BAUME, 31.5% Hcl), and Soda Ash.

❗ NOTE: Cette a pompe de dosage et ses composants ont été testés pour utilisation avec les produits chimiques suivants; Hypochlorite de Sodium (solution de 10-15%); Acide Muriatique (20-22 Baume, 31.5% Hcl); Cendre de Soude.

❗ NOTICE: This metering pump is portable and designed to be removable from the plumbing system without damage to the connections.

⚠ This is the safety alert symbol. When displayed in this manual or on the equipment, look for one of the following signal words alerting you to the potential for personal injury or property damage.

⚠ PUMP INTENDED FOR INDOOR USE.

⚠ Cette pompe est prévue pour utilisation à l'intérieur.

⚠ Electrical installation should adhere to all national and local codes. Consult a licensed professional for assistance with proper electrical installation.

⚠ Pump uses a class 2 auto switching power supply for AC input voltage rated 100-240VAC.

Pump Identification

Identify your pump using the label on the box or the pump.

Box Label

 STENNER Reliable Chemical Feed Pumps Since 1957	
MODEL/MODELO	SVP4
SERIAL NO./NO. DE SERIAL	02010503945
VOLTAGE/VOLTAJE	120
MAX GPD/MAX LPD	5/18.9 Adjustable
PSI/BAR	100/6.9
SUCTION/DISCHARGE TUBING TUBO DE SUCCION/DESCARGA	1/4" White 1/4" Blanco
ITEM NO./NO. DE PARTE	SVP4H1A1SUAA
3174 DeSalvo Road • Jacksonville, FL 32246	

← Model

← Serial Number

← Voltage

← Maximum Output per Day

← Maximum Operating Pressure

← Suction/Discharge Tubing

← Item Number for
Placing Order

Pump Identification continued

Pump Label



STENNER PUMP COMPANY

Jacksonville, FL
Phone: (904)641-1666
MADE IN U.S.A.

Thermally Protected Motor for Indoor Use
Motor Termal Protegido para el Uso Interior

⚠️ [WARNING] TO REDUCE RISK OF ELECTRIC SHOCK, CONNECT ONLY TO A PROPERLY GROUNDED GROUNDING-TYPE RECEPTACLE.

⚠️ [ATENCIÓN] PARA REDUCIR EL RIESGO DE DESCARGA ELECTRICA, CONECTELO A UN RECEPTACULO ELECTRICO CON CONEXION A TIERRA ADECUADO.

See installation instructions for over dosing protection.
Lea las instrucciones de instalación para evitar sobredosis de químicos.



THIS PRODUCT HAS BEEN TESTED AND CERTIFIED BY THE WATER QUALITY ASSOCIATION ACCORDING TO NSF/ANSI 61 FOR MATERIALS SAFETY ONLY.

METERING PUMP



LISTED
96FD

METERING PUMP



LR79585
NRTL /C

Model →

SVP4	SVP4H1A1SUAA
MODEL # NO. DE MODELO	ITEM # NO. DE PARTE

Maximum Operating Pressure →

100 psi / 6.9 bar	120VAC / 60Hz
--------------------------	----------------------

Amp Draw →

1.5 amp	5 GPD / 18.9 LPD
----------------	-------------------------

Agency Listings
(varies by model)

Item Number for Placing Order

Voltage

Maximum Output per Day

Serial Number

02010503945
SERIAL # NO. DE SERIAL

US and Canada call 1.800.683.2378, other countries call 1.904.641.1666

Outputs SVP series

Approx. Outputs @ 50 & 60 Hz

Variable Speed Series	Maximum Pressure	Pump Tube Number	range gallons per day	range liters per day	range gallons per hour	range liters per hour	range ounces per minute	range milliliters per minute
Variable Speed SVP1* SVP1 w/4-20mA Input SVP4* SVP4	100 psi/6.9 bar 25 psi/1.7 bar	#1	0.3 to 5.0	1.1 to 18.9	0.01 to 0.21	0.05 to 0.79	0.03 to 0.44	0.76 to 13.13
Variable Speed SVP1* SVP1 w/4-20mA Input SVP4* SVP4	100 psi/6.9 bar 25 psi/1.7 bar	#2	0.8 to 17.0	3.0 to 64.4	0.03 to 0.71	0.13 to 2.68	0.07 to 1.51	2.08 to 44.65
Variable Speed SVP1* SVP1 w/4-20mA Input SVP4* SVP4	100 psi/6.9 bar 100 psi/6.9 bar	#7	2.0 to 40.0	7.6 to 151.4	0.08 to 1.67	0.32 to 6.31	0.18 to 3.55	5.27 to 105.14
Variable Speed SVP1 w/4-20mA Input SVP4	25 psi/1.7 bar 25 psi/1.7 bar	#3	2.0 to 40.0	7.6 to 151.4	0.08 to 1.67	0.32 to 6.31	0.18 to 3.55	5.27 to 105.14
Variable Speed SVP1 w/4-20mA Input SVP4	25 psi/1.7 bar 25 psi/1.7 bar	#4	3.0 to 60.0	11.4 to 227.1	0.13 to 2.5	0.48 to 9.46	0.27 to 5.33	7.92 to 157.71
Variable Speed SVP1 w/4-20mA Input SVP4	25 psi/1.7 bar 25 psi/1.7 bar	#5	4.3 to 85.0	16.3 to 321.8	0.18 to 3.54	0.68 to 13.40	0.38 to 7.55	11.32 to 223.40

*pump supplied with injection check valve for 26-100 psi applications



NOTICE: The information within this chart is solely intended for use as a guide. The output data is an approximation based on pumping water under a controlled testing environment. Many variables can affect the output of the pump. Stenner Pump Company recommends that all metering pumps undergo field calibration by means of analytical testing to confirm their outputs.

Materials of Construction

All Housings* Lexan® Polycarbonate Plastic

Peristaltic Tube** Santoprene® FDA Approved
Check Valve Duckbill

Peristaltic Tube† Tygothane® FDA Approved
Check Valve Duckbill** Pellathane®

Suction/Discharge Tubing LDPE Polyethylene-NSF/FDA Approved
Ferrules (1/4" & 6mm)

Tube Fittings Type 1 Rigid PVC-NSF Listed
Connecting Nuts
Check Valve Fittings
Weighted Suction Line Strainer

All Fasteners Stainless Steel

*Lexan® is a registered trademark of General Electric.
Consult General Electric for chemical resistance of Lexan®.

†Tygothane® is a registered trademark of Saint-Gobain
Performance Plastics, Pittsburgh, PA.

**Santoprene® is a registered trademark of Advanced
Elastomer System, Akron, OH.

**Pellathane® is a registered trademark of The Dow
Company, Midland, MI.

Accessory Checklist – pre-installation

25 psi unit includes:

- (3) Connecting Nuts (1/4" or 3/8")
- (3) Ferrules w/1/4" & 6mm or
(2) Ferrules w/3/8"
- (1) Injection Fitting
- (1) Weighted Suction Line Strainer 1/4", 3/8", or 6mm
- (1) 20' Roll of Suction & Discharge Tubing
1/4" or 3/8" white or UV black
OR
6mm (Europe) white
- (1) Spare Pump Tube
- (1) Installation Manual

SVP4 also includes:

- (1) 4-20mA input signal cord

100 psi unit includes:

- (3) Connecting Nuts (1/4" or 3/8")
- (3) Ferrules w/1/4" & 6mm or
(2) Ferrules w/3/8"
- (1) Injection Check Valve
- (1) Weighted Suction Line Strainer 1/4", 3/8", or 6mm
- (1) 20' Roll of Suction & Discharge Tubing
1/4" or 3/8" white or UV black
OR
6mm (Europe) white
- (1) Spare Pump Tube
- (1) Installation Manual

SVP4 also includes:

- (1) 4-20mA input signal cord

Installation – additional safety instructions

! **NOTICE:** Indicates special instructions or general mandatory action.

- !** Read all safety hazards before installing or servicing the pump. The pump is designed for installation and service by properly trained personnel.
- !** Use all required personal protective equipment when working on or near a chemical metering pump.
- !** Install the pump so that it is in compliance with all national and local plumbing and electrical codes.
- !** Use the proper product to treat potable water systems, use only chemicals listed or approved for use.
- !** Install the pump to work in conjunction with pool, spa, well pump, or system controls.

Installation continued – definitions

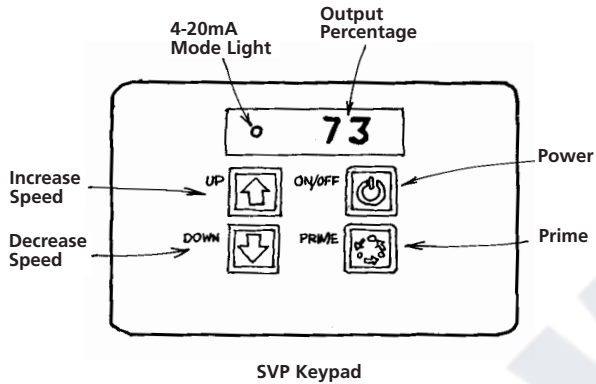

Manual Mode of Operation

The pump is operated by manually adjusting the motor speed with the keypad. **SVP1 and SVP models.**

Automatic Mode of Operation

The pump is paced by an external 4-20mA signal, LED light illuminate. **SVP4 models only.**

Installation continued – mount pump

MOUNT PUMP

Select mounting surface.

- ❗ Select a dry location (to avoid water intrusion and pump damage) above the solution tank.
- ❗ To prevent pump damage in the event of a pump tube leak, never mount the pump vertically with the pump head up.
- ❗ To avoid chemical damage from fumes, do not mount pump directly over an open solution tank. Keep tank covered.
- ❗ Avoid flooded suction or pump mounted lower than the solution container. Draw solution from the top of the tank. If pump is installed with a flooded suction, a shut-off valve or other device must be provided to stop flow to pump during service.
- ❗ Do not allow water intrusion into the motor or corrosion and damage will occur.

Installation Diagram

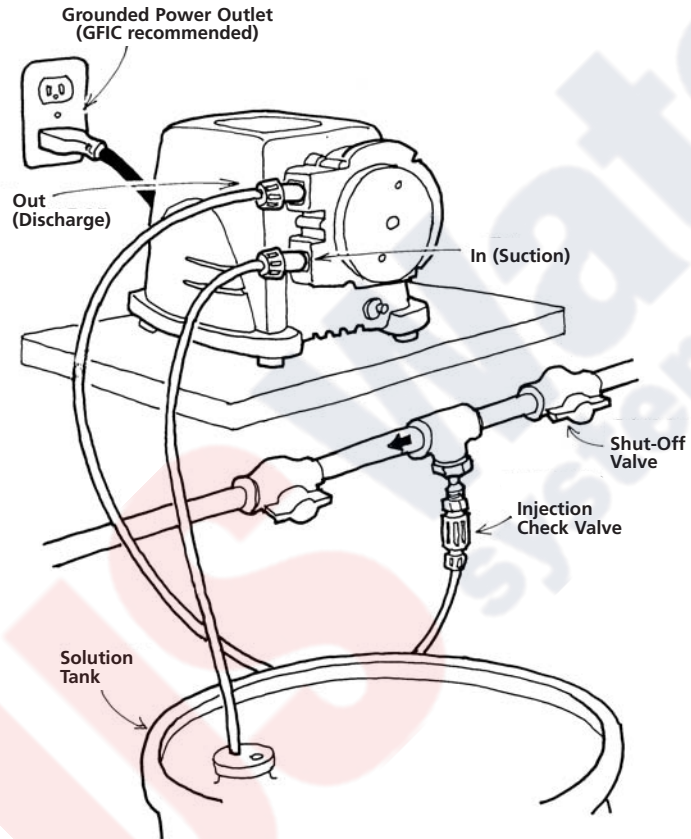

Installation continued – verify voltage and power

! To prevent motor damage, verify with a volt meter that the receptacle voltage corresponds with the pump voltage.

1. Plug cord into receptacle.
2. Depress the ON/OFF button located on the keypad to verify the unit is turned on. Red LED display will light up when supply voltage is present and unit is turned ON.

SVP1 models:

The SVP1 does not have 4-20mA capabilities and only operates in **manual mode** of operation. The output can be incremented through its available speed range by utilizing the UP/DOWN keys on the keypad. Depress the ON/OFF button once again to turn the pump off. **Proceed to the Install Suction Line steps.**

SVP4 models:







In the **manual mode** of operation, the metering pump functions identically to the SVP1. To change to **automatic mode** of operation, simultaneously depress both the UP and DOWN keys and hold for two seconds. The mode of operation will change and be indicated by a small LED light located at the left side of the display. Any settings entered in the variable speed mode will remain in memory.

3. Depress ON/OFF button again to turn the metering pump off.







More on next page...

Installation continued – verify voltage and power

 **WARNING** RISK OF EQUIPMENT MALFUNCTION
OR DAMAGE:

-  **DO NOT** connect input signal cord to any AC electrical supply.
-  **DO NOT** exceed 48VDC input signal.
-  Pump is not a source or power supply for the 4-20mA signal loop. Refer to input signal specifications.
-  Pump and input signal **must be** “OFF” prior to connecting input signal. Failure to follow this warning may result in microcontroller corruption and erratic operation.
-  Failure to connect input signal with proper polarity will result in the pump not responding to the input signal.
-  The LED display can vary if the pump is exposed to a 9-30MHz signal when operating in the “automatic” mode.

 **AVERTISSEMENT** RISQUE DE DEFAUT DE
FONCTIONNEMENT OU DE DOMMAGES A L'EQUIPEMENT:

-  **NE JAMAIS** connecter le cordon du signal d'entrée à n'importe quelle source de courant alternatif.
-  Ne pas excéder le signal d'entrée 48VDC.
-  La pompe n'est pas une source ni une alimentation en courant pour la boucle de signal 4 à 20mA. Consulter les spécifications du signal d'entrée.
-  **Mettre sur Arrêt** (“OFF”) la pompe et le signal d'entrée, avant d'effectuer la connexion du cordon du signal d'entrée. Si cette précaution n'est pas prise, la micro-contrôleur risque d'être corrompu et le fonctionnement irrégulier.
-  Si le signal d'entrée n'est pas connecté à la polarité appropriée, la pompe ne réagira pas à ce signal.
-  L'afficheur LED peut varier si la pompe est exposée à un signal 9-30MHz en fonctionnant en mode “automatique.”

SVP4 models:

If using the automatic mode of operation (4-20mA DC analog signal), plug the input signal connector (gray jacketed 6' cable) to the receptacle located on the front of the pump beneath the pump head. Connect the jacketed cable to the supply conductor (4-20mA source) ensuring proper polarity. Red is positive, black is negative.

Installation continued – suction line

INSTALL SUCTION LINE

1. Uncoil the suction line and cut a section to assure that the end will be 2-3" above the bottom of the solution tank. Use the outside of the solution tank as a guide to cut to proper length.

! Allow sufficient slack to avoid kinks and stress cracks. Always make a clean square cut to assure that the suction line is burr free. Normal maintenance requires trimming.

! Suction lines that extend to the bottom of the tank can result in debris pickup leading to clogged injectors and possible tube failure.

2. Slide the suction line through the connecting nut and ferrule and fully insert the line into the bottom pump tube fitting as indicated by the "IN" on the tube housing cover.

3. Finger tighten nut to the threaded tube fitting while holding the tube fitting.

! Over tightening the ferrule and nut with a wrench may result in damaged fittings, crushed ferrules, and air pickup.

! Do not use thread sealant tape on pump tube connections or tools to tighten connections.

More on next page...

DO NOT use Teflon tape on pump tube threads.

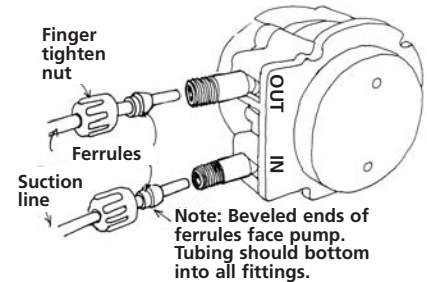
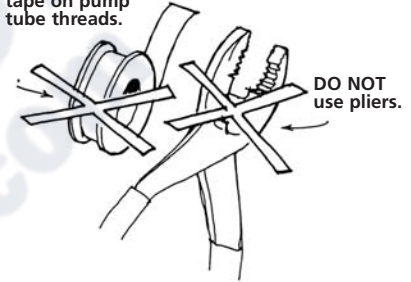

Installation continued – suction line

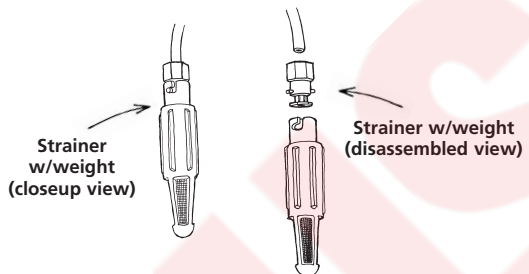
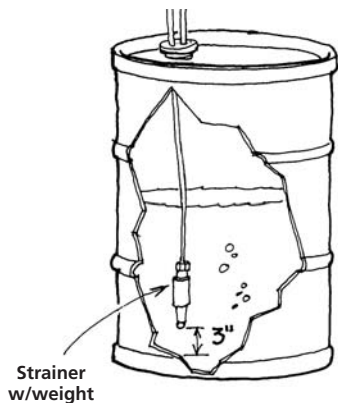

4. Drill a 17/64" hole into the lid or bung cap of the solution tank. Secure strainer weight to the end of the suction line as per provided instructions and feed it into the hole.
5. Suspend 2-3" above the tank bottom.



Do not mix chemicals in the solution container. Follow recommended mixing procedures according to the manufacturer.



Do not operate pump unless chemical is completely in solution. Turn pump off when replenishing solution.

Installation continued – discharge line

INSTALL DISCHARGE LINE

! The injection point and fitting require periodic maintenance to clean any deposits or buildup. To allow quick access to the point of injection, Stenner recommends the installation of shut-off valves.

26-100 psi models:

- Prior to making tubing connection, test check valve and NPT threads for leaks by pressurizing system.
- Tighten an additional 1/4 turn if necessary. Make final tube connection as instructed in Install Suction Line instructions.

0-25 psi models:

Low-pressure models do not have a check valve and check valve body. Insert the tubing 3/4" to 1" into the injection fitting and make tubing connection as instructed in Install Suction Line instructions.

1. Depress and hold the PRIME button on the keypad and allow the pump to fully prime. The Prime key will operate the pump at 100% but will not display 100% on the keypad.

More on next page...

Typical Point of Injection

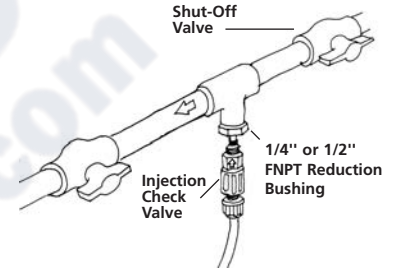

HAZARDOUS PRESSURE:
Shut off water or circulation system and bleed off any system pressure.

Installation continued – discharge line

SVP1 models:

Use the manual mode of operation to set the metering pump to the desired speed required for the application. This is the initial setting. Check the entire system for leaks. **Proceed to Step 2.**

SVP4 models:

For automatic mode of operation, verify that the 4-20mA LED light is displayed on the keypad. Provide the required signal for the automatic mode of operation. The pump will respond to the 4-20mA input signal and pace accordingly. **Proceed to Step 2.**

- 4.0-4.7mA = OFF or Zero (0) percent motor speed.
- 4.8-19.9mA: the pump will operate in 1% increments every 0.16mA.
- Above 19.9mA the pump will operate at 100% motor speed.
- The pump's minimum speed is 5% @ 4.8mA.

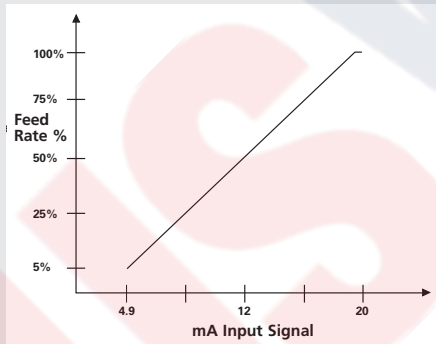

2. After a suitable amount of dosing time, verify the application with test equipment. Perform final adjustments to the pump settings to provide the required residual or results as determined through adequate test equipment or analysis.

Troubleshooting – motor

PROBLEM	POSSIBLE CAUSE	SOLUTION
Keypad/Display	 WARNING HAZARDOUS VOLTAGE: DISCONNECT power cord before removing motor cover for service. Electrical service should be performed by trained personnel only.	
Display is blank.	No AC power at receptacle. Pump is off. Failed power supply.	Check voltage of receptacle/controller output voltage. Depress ON/OFF key. Check power supply. Green LED "ON" with AC voltage applied. Check 12VDC output to board.
No response to 4-20mA signal.	Not in "AUTOMATIC."	Ensure display has a small LED light located in upper left-hand corner indicating pump is in "AUTOMATIC."
Display reads "00" and does not respond when pressing UP/DOWN keys.	Pump is in "AUTOMATIC" mode of operation.	Place pump in "MANUAL" mode.
DC Motor		
Display working; pump is not.	Worn motor brushes. Failed DC motor.	Inspect brushes for wear, replace if needed. Replace DC gear motor if brushes are good.
Pump cycles ON/OFF.	Failed DC fan.	Check fan operation. Replace as required.

Troubleshooting continued – pump head

PROBLEM	POSSIBLE CAUSE	SOLUTION
Pump Head		
Components are cracking.	Chemical attack.	Check chemical compatibility.
Visible fluid in pump head.	Pump tube rupture/leak.	Replace pump tube and ferrules and center.
No pump output; pump head rotates.	Depleted solution tank. Pump suction line weight is above solution. Suction line leak. Ferrules installed incorrectly or damaged. Injection point is clogged. Clogged suction/discharge tubing and/or injection check valve. Life of pump tube is exhausted.	Replenish solution. Maintain suction line 2-3" off bottom of tank. Inspect or replace suction line. Replace compression ferrules. Inspect and clean injection point. Clean and/or replace as necessary. Replace pump tube.
Low pump output; pump head rotates.	Pump tube is worn. Rollers missing or cracked. Injection point is restricted. High system back pressure.	Replace pump tube. Install new roller or roller assembly. Inspect and clean injection point. Check tube against system pressure; replace accordingly.
No pump output; pump head not rotating.	Roller assembly is stripped. Motor problem.	Replace roller assembly. Replace DC motor.
Pump output is high.	Incorrect tube size. Roller assembly is broken.	Replace tube with correct size. Replace roller assembly.

Troubleshooting continued – pump tube

PROBLEM	POSSIBLE CAUSE	SOLUTION
Pump Tube <div style="display: flex; align-items: center;">  <p>NOTICE: A leaking pump tube damages the metering pump. Inspect pump frequently for leakage and wear. Refer to Tube Replacement section for additional safety precautions and instructions.</p> </div>		
Tube is leaking.	Pump tube has ruptured. Calcium or mineral deposit. Excessive back pressure. Tube is twisted. Tube is not centered.	Replace pump tube at routine intervals. Clean injection fitting, replace pump tube. Check tube psi rating against system pressure; replace accordingly. Replace tube according to instructions. Replace tube and center it.
Tube life is shortened.	Chemical attack. Mineral deposit at injection point. Sediment blockage at check valve. Degraded check valve duckbill. Duckbill in wrong orientation. Tube was manually stretched to lock into discharge side slot. Seized rollers caused abrasion on tube.	Check chemical compatibility. Remove deposit and replace pump tube. Maintain suction line 2-3" above bottom of tank. Use a suction line strainer. Replace check valve duckbill at every tube change. Reverse duckbill orientation. See tube replacement instructions. Allow roller assembly to stretch tube into place. Clean roller assembly or replace.

Separating and Reconnecting Subassemblies

Separating Subassemblies

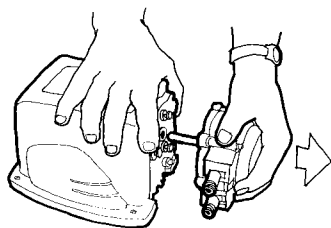

1. Turn off the pump and unplug the power cord.
2. Hold the pump motor section and turn the pump head clockwise, until it stops.
3. Pull the pump head straight out and off.

Note: Older pumps or pumps that have had a tube rupture may require the use of a flat blade screwdriver to assist in pump head removal. Insert the screwdriver behind the pump head and carefully pry the pump head off the motor shaft while pulling.

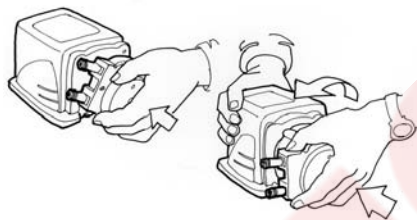





Reconnecting Pump Head to Motor

1. Hold the pump motor section and insert the motor shaft into the pump head making sure the flat of the motor shaft aligns with the corresponding flat of the roller assembly.
2. Rotate the pump head until the locking rivets on the front of the pump motor align with the corresponding mounting locations of the pump head.
3. Push the head onto the motor shaft until it bottoms.
4. Turn counterclockwise to engage mounting rivets.

Tube Replacement – safety information



WARNING RISK OF CHEMICAL EXPOSURE:

-  To reduce risk of exposure, check the pump tube regularly for leakage. At the first sign of leakage, replace the pump tube.
-  To reduce risk of exposure, the use of proper personal protective equipment is mandatory when working on or near chemical metering pumps.
-  To reduce risk of exposure, and also prior to service, shipping, or storage, pump generous amounts of water or a compatible buffer solution to remove chemical from pump.
-  Consult chemical manufacturer and MSDS sheet for additional information and precautions for the chemical in use.
-  Personnel should be skilled and trained in the proper safety and handling of the chemicals in use.





CAUTION PINCH POINT HAZARD:

-  Use extreme caution when replacing pump tube. Be careful of your fingers and **DO NOT** place fingers near rollers.

WARNING HAZARDOUS PRESSURE/CHEMICAL EXPOSURE:

-  Use caution and bleed off all resident system pressure prior to attempting service or installation.
-  Use caution when disconnecting discharge tubing from pump. Discharge may be under pressure. Tubing may contain chemical.

NOTICE: Indicates special instructions or general mandatory action.

-  **NOTICE: Do not** apply grease, oil, or lubricants to the pump tube or housing.
-  **NOTICE:** Prior to pump tube replacement, inspect the entire pump head for cracks or damaged components. Ensure rollers turn freely.
-  **NOTICE:** Rinse off chemical residual and clean all chemical and debris from pump head components prior to tube replacement. Apply Stenner grease to main shaft and tube housing cover bushing during tube replacement.
-  **NOTICE: DO NOT** pull excessively on pump tube. Avoid kinks or damage during tube installation.
-  **NOTICE:** Inspect the suction/discharge tubing, injection point (into pipe), and injection check valve duckbill for blockages after any tube rupture. Clear or replace as required.

Tube Replacement continued – preparation

1. Follow all safety precautions prior to tube replacement.
2. Prior to service, pump water or a compatible buffer solution through the pump and suction/discharge line to remove chemical and avoid contact.
3. Turn pump off.
4. Disconnect the suction and discharge connections from pump head.
5. Plug power cord into constantly energized, properly grounded receptacle for service.

Tube Replacement continued – remove old tube

REMOVE OLD TUBE

1. Place the pump in manual mode of operation and set this display to 05.
2. Turn the pump off.
3. Remove the screws and the tube housing cover.
4. Depress the PRIME button located on the keypad to jog the roller assembly until one of the three slots in the roller assembly lines up with the bottom tube fitting (suction side). **Illustration A**
5. Lift tube fitting out of housing slot and pull it toward center of roller assembly. **Illustration B**
6. Turn pump on and allow roller assembly to jog while guiding tube, with tension, up and out of housing. **Illustration C**
7. Turn pump off. Remove and discard pump tube.
8. Remove roller assembly and housing.
9. Use non-citrus all-purpose cleaner to clean chemical residue from pump head housing, roller, and cover.
10. Check housing for cracks. Replace if cracked.
11. Ensure rollers spin freely. **Illustration D**
12. Replace roller assembly if: seized, excessive side play from bore wear, or if rollers are visibly worn.
13. Reinstall clean tube housing.
14. Install roller assembly.

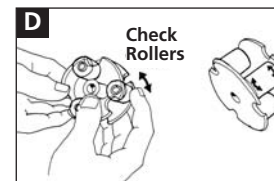
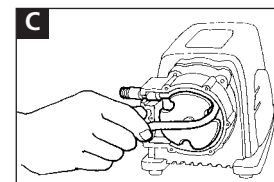
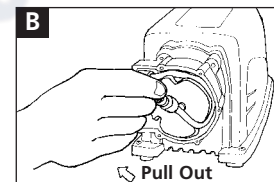
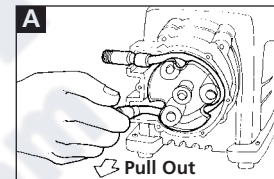

Tube Replacement continued – install new tube

IMPORTANT! Do not lubricate pump tube or roller assembly.

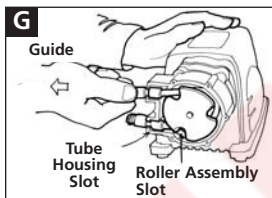
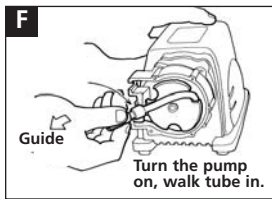
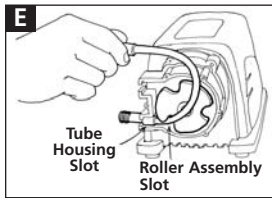

NOTE: Cover Screws are self-tapping and must be backed in to locate original thread before securing. If a screw boss is stripped, use alternate bosses and position opposite from each other. Never secure the cover plate with more than 2 screws.

INSTALL NEW TUBE

1. With the power on in manual mode, verify that the setting is O5. Turn the pump off. Depress the PRIME button located on the keypad until one of the slots in the roller assembly aligns with the "in" (suction) tube fitting slot in the housing. **Illustration E**
2. Place tube fitting into suction side slot of the housing and the roller assembly slot. **Illustration E**
3. With pump setting on O5, hold tube fitting and jog roller assembly by turning pump on. **Illustration F**
4. Guide tube, with slight tension (toward the center) to prevent pinching between housing and roller assembly. **Illustration G**
5. When tube reaches the top housing slot, turn pump off.
6. Depress the PRIME button to allow rollers to stretch tube into place while guiding tube into slot. **Illustration G**
7. Turn pump off.

NOTE: An old tube will stretch approximately 3/4" and the new tube will appear to be stiff and short. Follow directions to allow rollers to stretch tube into place.

IMPORTANT! Avoid rotating wrist, which can result in a twisted tube that will not center. Do not force tube and be careful of your fingers.

8. Apply a small amount of grease (AquaShield®) to cover bushing ONLY and replace cover and two screws, leaving front screw in-between the fittings loose.

Tube Replacement continued – center new tube

CENTER NEW TUBE

1. To center pump tube on rollers, depress and hold the PRIME button to continually rotate the rollers. **Illustration H**
2. Turn the tube fitting on the suction side not more than 1/8 of a turn in the direction tube must move.
3. Do not let go of fitting until tube rides approximately in center of rollers.
4. Release the PRIME button. Tighten cover screws. Cover is not on securely if there is a gap between screw boss and cover.

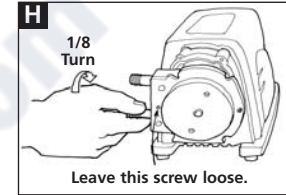

Cleaning the Point of Injection – safety information

NOTICE: Indicates special instructions or general mandatory action.

NOTICE: Low-pressure models are installed using an injection fitting and high-pressure models use an injection check valve. Both allow the extension tip to be installed in the center of the pipe directly in the flow of water to help reduce deposit accumulation.

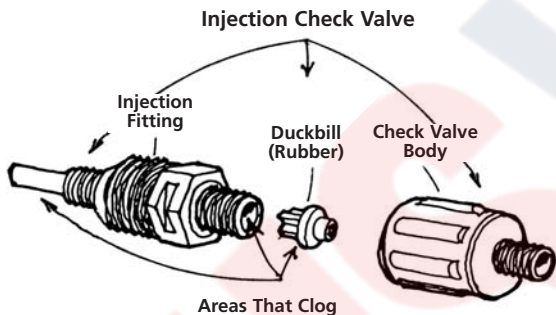

WARNING Warns about hazards that CAN cause death, serious personal injury, or property damage if ignored.

! This is the safety alert symbol. When displayed in this manual or on the equipment, look for one of the following signal words alerting you to the potential for personal injury or property damage.

! **WARNING** HAZARDOUS PRESSURE/CHEMICAL EXPOSURE:

! Use caution and bleed off all resident system pressure prior to attempting service or installation.

! Use caution when disconnecting discharge tubing from pump. Discharge line may be under pressure. Tubing may contain chemical.

! To reduce risk of exposure, the use of proper personal protective equipment is mandatory when working on or near chemical metering pumps.

Cleaning the Point of Injection continued

1. Turn metering pump off and unplug cord. Disable water pump or auxiliary equipment electrical supply.
2. Depressurize system and bleed pressure from pump discharge tubing.
3. Loosen and remove connecting nut and ferule from the injection check valve or injection fitting to disconnect discharge tubing.
4. Insert a #2 Phillips head screwdriver through injection fitting into the pipe to locate or break up accumulated deposits. If screwdriver cannot be inserted, drill the deposit out of the injection fitting. (Do not drill through the opposite pipe wall.)

More on next page...

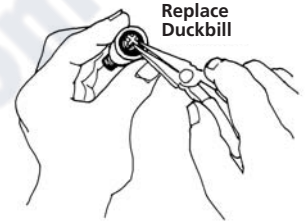

Periodic inspection and cleaning of the point of injection will maintain proper pump operation and provide maximum tube life.

26-100 psi models:

- Unscrew the top fitting (check valve body) to disassemble. The bottom fitting (injection fitting with arrow) should remain attached to the pipe.
- Remove duckbill from check valve body and replace if deteriorated or swollen (yearly replacement recommended). If clogged, clean or replace.
- Examine O-ring in the injection fitting and replace if deteriorated or damaged.

Cleaning the Point of Injection continued

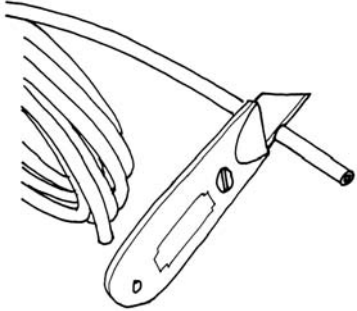

Cut off the calcified or blocked section.

5. Replace discharge tubing if cracked or deteriorated. If the end is clogged, cut off the calcified or blocked section of tubing.

0-25 psi models:

Replace ferrule and reinstall the discharge tubing to the injection fitting approximately 3/4"-1" until it stops.

26-100 psi models:

- Reassemble the injection check valve in reverse order.
- Replace ferrule and reinstall the discharge tubing to the injection check valve approximately 3/4" until it stops.

6. Tighten the connection nut finger tight.
7. Enable the water pump electrical supply and pressurize the water system.
8. Put the metering pump back in service and inspect all connections for leaks.

Motor – exploded view

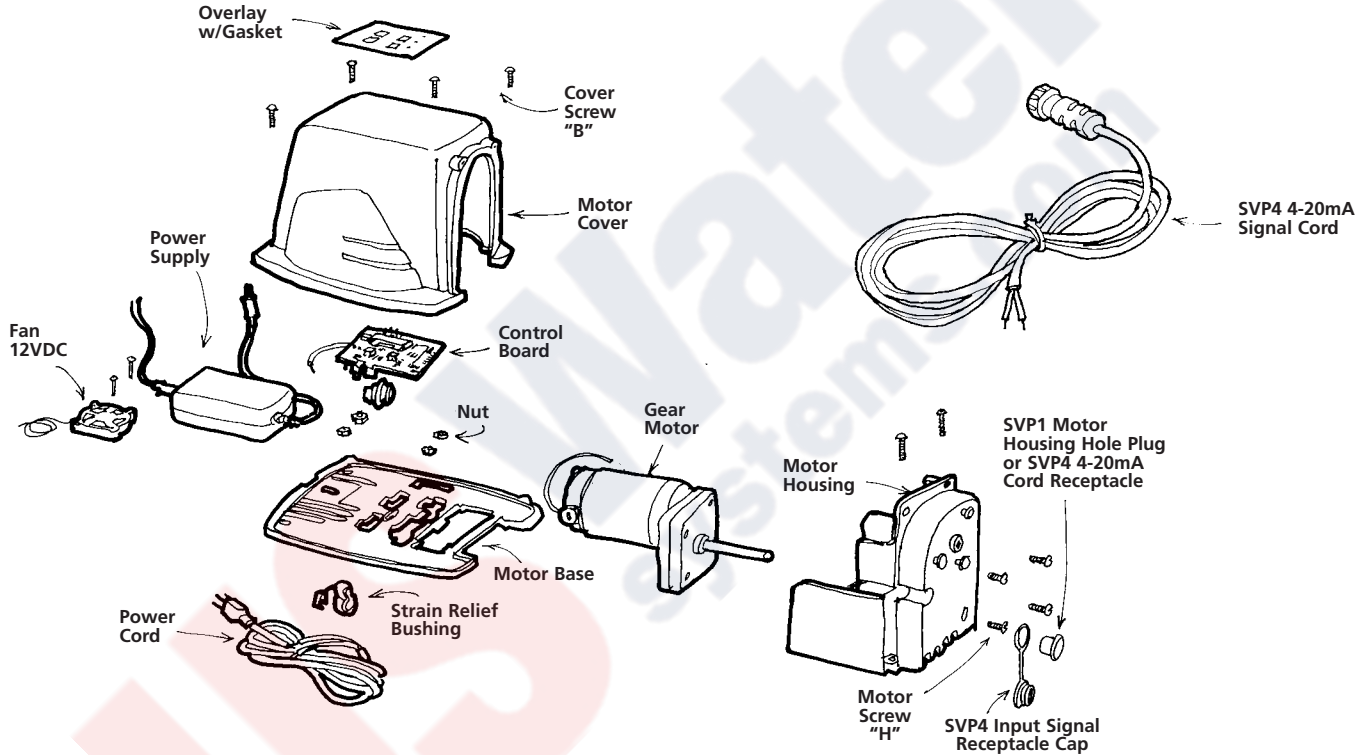

Contact factory for part numbers.

US and Canada call 1.800.683.2378, other countries call 1.904.641.1666

Pump Head – exploded view

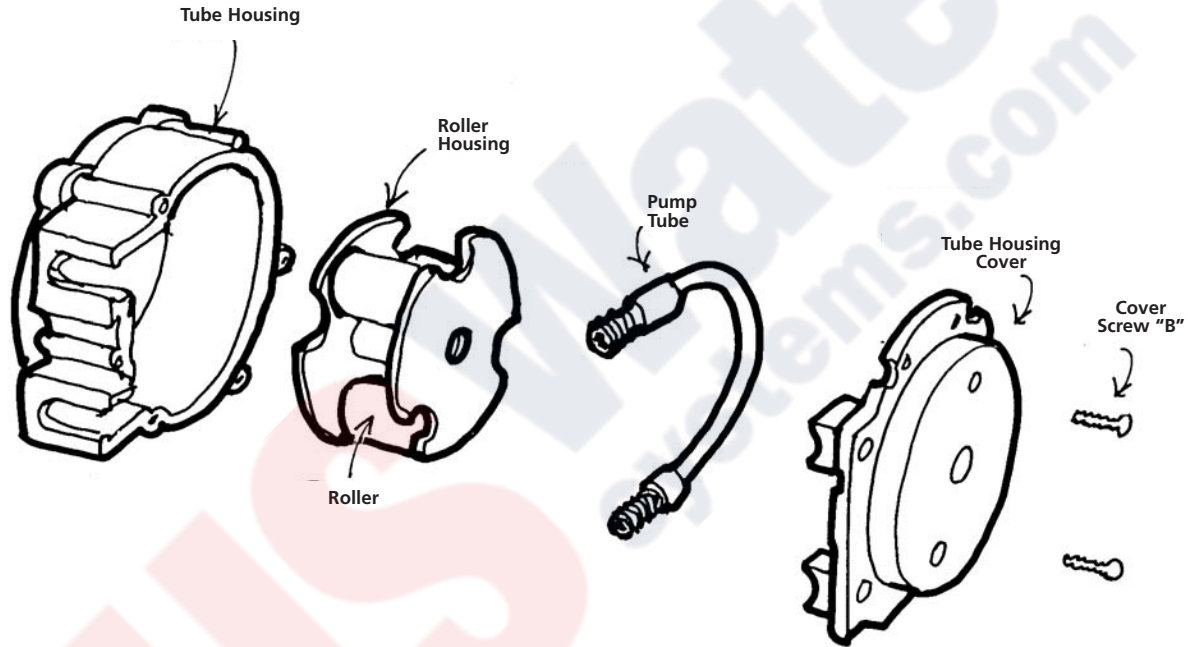

Pump Head continued – subassemblies

PUMP HEADS

DESCRIPTION	PART NUMBER	UM	PART NUMBER	UM
Pump Head includes SANTOPRENE® pump tube, ferrules 1/4"	UCTHC_*_D	EA	MCTHC_*_D	PK of 2
	* select tube number 1, 2, 3, 4, 5, 7			
Pump Head includes SANTOPRENE® pump tube & duckbill, ferrules 1/4"	UCPH_*_FD	EA	n/a	n/a
	* select tube number 1, 2, 7			
Pump Head includes TYGOTHANE® pump tube, ferrules 1/4"	UCPHT0_*	EA	n/a	n/a
	* select tube number 2, 5			
Pump head includes TYGOTHANE® #2 pump tube, PELLATHANE® duckbill, ferrules 1/4"	UCPHTD2	EA	n/a	n/a

EUROPE

Pump Head includes SANTOPRENE® pump tube, ferrules 6mm	UCTH_*_CE	EA	MCTH_*_CE	PK of 2
	* select tube number 1, 2, 3, 4, 5, 7			
Pump Head includes SANTOPRENE® pump tube & duckbill, ferrules 6mm	UCPH_*_CE	EA	n/a	n/a
	* select tube number 1, 2, 7			
Pump Head includes TYGOTHANE® pump tube, ferrules 6mm	UCPHT_*_CE	EA	n/a	n/a
	* select tube number 2, 5			
Pump head includes TYGOTHANE® #2 pump tube, PELLATHANE® duckbill, ferrules 6mm	UCPHD2CE	EA	n/a	n/a

Pump Head

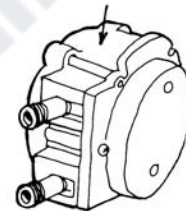

Pump Tube Numbers

#1 and #2 for 26-100 psi pump (when used with check valve).

#1, 2, 3, 4, 5 for 0-25 psi pump.

#7 tube for 26-100 psi single head pump only.

Pump Head continued – service kits

PUMP HEAD SERVICE KITS

DESCRIPTION	PART NUMBER	UM
-------------	-------------	----

0-25 psi/1.7 bar

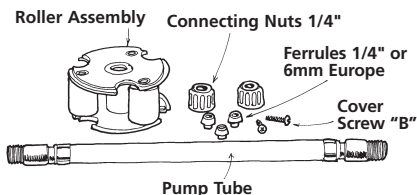

SANTOPRENE® Kit (0-25 psi)	PSKLO * * select tube number 1, 2, 3, 4, 5	KIT
SANTOPRENE® Kit (26-100 psi)	PSKH0 * * select tube number 1, 2, 7	KIT
TYGOTHANE® Kit (0-25 psi)	PSKLT * * select tube number 2 or 5	KIT
KIT: (26-100 psi) TYGOTHANE® #2 Pump Tube & PELLATHANE® duckbill included	PSKHT2	KIT

EUROPE

26-100 psi/6.9 bar

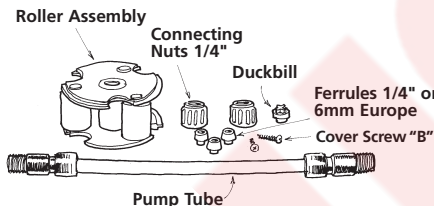

SANTOPRENE® Kit (1.7 bar)	PSKL * CE * select tube number 1, 2, 3, 4, 5	KIT
SANTOPRENE® Kit (1.7-6.9 bar)	PSKH * CE * select tube number 1, 2, 7	KIT
TYGOTHANE® Kit (1.7 bar)	PSKLT * CE * select tube number 2 or 5	KIT
KIT: TYGOTHANE® #2 Pump Tube & PELLATHANE® duckbill included	PSKHT2CE	KIT

Pump Tubes

PUMP TUBES

DESCRIPTION	PART NUMBER	UM	PART NUMBER	UM
SANTOPRENE® Pump Tube includes ferrules 1/4"	UCCP20 *	PK of 2	MCCP20 *	PK of 5
	* select tube number 1, 2, 3, 4, 5, 7			
SANTOPRENE® Pump Tube & duckbill , ferrules 1/4"	UCCP_*_FD	PK of 2	n/a	n/a
	* select tube number 1, 2, 7			
TYGOTHANE® Pump Tube , ferrules 1/4"	UCTYG0 *	PK of 2	MCTYG0 *	PK of 5
	* select tube number 2, 5			
TYGOTHANE® #2 Pump Tube & PELLATHANE® duckbill , ferrules 1/4"	UCTY2FD	PK of 2	n/a	n/a

EUROPE

SANTOPRENE® Pump Tube includes ferrules 6mm	UCCP2_*_CE	PK of 2	MCCP2_*_CE	PK of 5
	* select tube number 1, 2, 3, 4, 5, 7			
SANTOPRENE® Pump Tube & duckbill , ferrules 6mm	UC_*_FDCE	PK of 2	n/a	n/a
	* select tube number 1, 2, 7			
TYGOTHANE® Pump Tube includes ferrules 6mm	UCTY_*_CE	PK of 2	MCTY_*_CE	PK of 5
	* select tube number 2, 5			
TYGOTHANE® #2 Pump Tube & PELLATHANE® duckbill , ferrules 6mm	UCTY2DCE	PK of 2	n/a	n/a

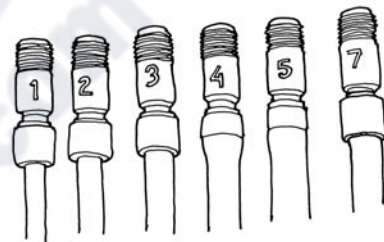

Pump Tube Numbers

#1 and #2 for 26-100 psi pump
(when used with check valve).

#1, 2, 3, 4, 5 for 0-25 psi pump.

#7 tube for 26-100 psi single
head pump only.

Check Valves

Injection Check Valve 1/4"



Injection Check Valve 3/8"



Injection Check Valve 6mm



CHECK VALVES

DESCRIPTION	PART NUMBER	UM	PART NUMBER	UM
Check Valve includes SANTOPRENE® duckbill, ferrules 1/4"	UCDBINJ	EA	MCDBINJ	PK of 5
Check Valve includes PELLATHANE® duckbill, ferrules 1/4"	UCTYINJ	EA	MCTYINJ	PK of 5
Check Valve includes SANTOPRENE® duckbill, ferrules 3/8"	UCINJ38	EA	MCINJ38	PK of 5
Check Valve includes PELLATHANE® duckbill, ferrules 3/8"	UCTYIJ38	EA	MCTYIJ38	PK of 5
EUROPE				
Check Valve includes SANTOPRENE® duckbill, ferrules 6mm	UCINJCE	EA	MCINJCE	PK of 5
Check Valve includes PELLATHANE® duckbill, ferrules 6mm	UCTINJCE	EA	MCTINJCE	PK of 5

For Your Records

Model: _____

Serial Number: _____

Date of Installation: _____



STENNER

Metering Pumps
Manufactured Since 1957

Stenner Pump Company
3174 DeSalvo Road
Jacksonville, Florida 32246
sales@stenner.com
www.stenner.com

Phone: 904.641.1666
US Toll Free: 800.683.2378
Fax: 904.642.1012

Hours of Operation (EST):
Mon. – Fri. 7:00 am – 5:30 pm