

Visit us online at
www.uswatersystems.com

US Water
systems.com

American Revolution 5-Stage RO System

The only RO System on the market that is totally American-Made!



Owners Manual

Models:

200-USRO, 200-USRO-P

REVISION # 1.3
REVISION DATE March 11, 2015

US Water Systems Corporate Office
1209 Country Club Road
Indianapolis, IN 46234

Parts Check List

- RO Module
- Tubing Bundle
- Filter Wrench
- Drain Saddle
- Tank Valve
- Angle Stop Feed Valve
- Tank and Side Mount Tank Stand
- Faucet and Mounting Kit
- Faucet Connector
- Pre and Post Filters
- Membrane
- Installation Instructions

MEMBRANE **POST CARBON** **PRE SEDIMENT** **PRE CARBON**

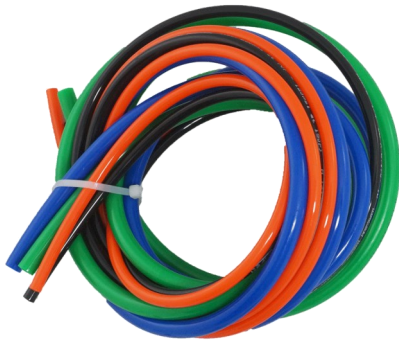

TUBING

FILTER WRENCH



TANK VALVE



FAUCET AND MOUNTING KIT

FAUCET CONNECTOR



FEED WATER ANGLE STOP



DRAIN SADDLE



Components of the RO System

PRE-FILTER (sediment filter) removes larger particles such as sand, silt, rust and scale, (activated carbon filters) remove chlorine in the feed water to protect the reverse osmosis membrane.



REVERSE OSMOSIS MEMBRANE reduces *dissolved* minerals, metals and salts. During the process, harmful compounds are separated by the membrane and the reject water goes to waste (drain).



An activated carbon **POST-FILTER** is provided for a final “polish” and to remove foul tastes, odors and to provide great tasting drinking water.



FILTER HOUSINGS and **R/O MODULE** hold pre-filters and membranes. A **BRACKET** is provided so they may be mounted, typically below sink.



STORAGE TANK holds filtered water, ready for use.

AUTOMATIC SHUT-OFF VALVE (ASO) senses when the storage tank is full and closes the water supply to conserve water. (not used in permeate pump system)



PERMEATE PUMP is used to pressurize the tank and distribution system. This pump is operated by the drain water. The permeate pump will dramatically increase the faucet pressure. A permeate pump system will not have an ASO valve.



The dedicated **FAUCET** is used to dispense RO produced water when needed.

FEED WATER ANGLE STOP VALVE is connected to the cold water line to supply water to the R/O system.



WASTE WATER SADDLE VALVE is connected to the drain to remove reject water from the R/O system.



TUBING supplies feed and reject water.

FITTINGS are used for necessary hose connections.

Tools

The following tools may be necessary, depending on each particular installation:

- 3/8" Drill and 1/4" drill bit and Faucet Drill bit (Standard Faucet use a 7/16" drill bit, Air Gap Faucet uses a 7/8" minimum and 1 1/8" maximum drill bit).
- Phillips head and flat blade screwdrivers
- Adjustable wrench
- Crescent wrench
- Teflon tape
- Plastic tube cutter



Location

Your R/O system may be installed under a sink, in a basement or other location, depending on available space. Do not install unit where temperatures fall below freezing; otherwise, damage will result. Connection to an icemaker should also be considered for optimum performance.

Guidelines for component placement are as follows:

FAUCET should be placed near the sink where drinking/ cooking water is normally required. A 2" flat surface is required to mount the faucet if an existing hole for a second faucet is not available. The thickness of the mounting thickness should not exceed 1-1/4".

STORAGE TANK may be placed where it is convenient, within ten feet of the RO module. Under the sink or in a nearby cabinet are excellent choices. Full tanks may weigh more than thirty pounds, so a sturdy shelf is required.

RO MODULE may be mounted on either side of the sink, in a cabinet or heated basement, with nearby access to a potable, cold water line and a sanitary drain.

Installation Instructions

Residential Reverse Osmosis Drinking Water System

FEED WATER CONNECTION is accomplished with an angle stop feed water valve. This valve will be installed in the cold water line between the sink cold water shutoff valve and the sink faucet tubing. Connect to a potable, cold water supply line only.

NOTE: *Softened water is preferred since it will extend the life of your R/O membrane.*

DRAIN CONNECTION is accomplished using a waste water saddle valve which is designed to fit around a standard 1-1/2" OD drain pipe. The drain saddle valve should always be installed above (before) the trap and on the vertical or horizontal tailpiece.

Do not install the drain saddle valve near a garbage disposal; otherwise, plugging of the waste water line may occur. If discharging into a utility sink or standpipe, an air gap may be needed. (Air gaps must be 1" or greater above the floor or pipe rim). US Water offers other drain line connection options on www.uswatersystems.com

RO System Installation Procedure

NOTE: All plumbing must be completed in accordance with state and local plumbing codes. Some municipalities may require the installation be performed by a licensed plumber. Check your local authority prior to installation.

A. Faucet installation

If the sink has a sprayer it may be disconnected for faucet installation. A pipe cap or plug will be necessary to seal the sprayer connection. To make the faucet mounting hole (if sprayer or second hole is not used), check below to make sure the drill does not interfere with anything below. Drill a 7/8" minimum 1 1/8" maximum hole for air gap faucet installations. Be sure to use a bit compatible with your surface. Clean up sharp edges. The faucet should be positioned so it empties into the sink and the spout swivels freely for convenience. If sink has a hole that can accommodate the RO faucet, no drilling is required. Proceed with mounting the faucet.

Fig. 1

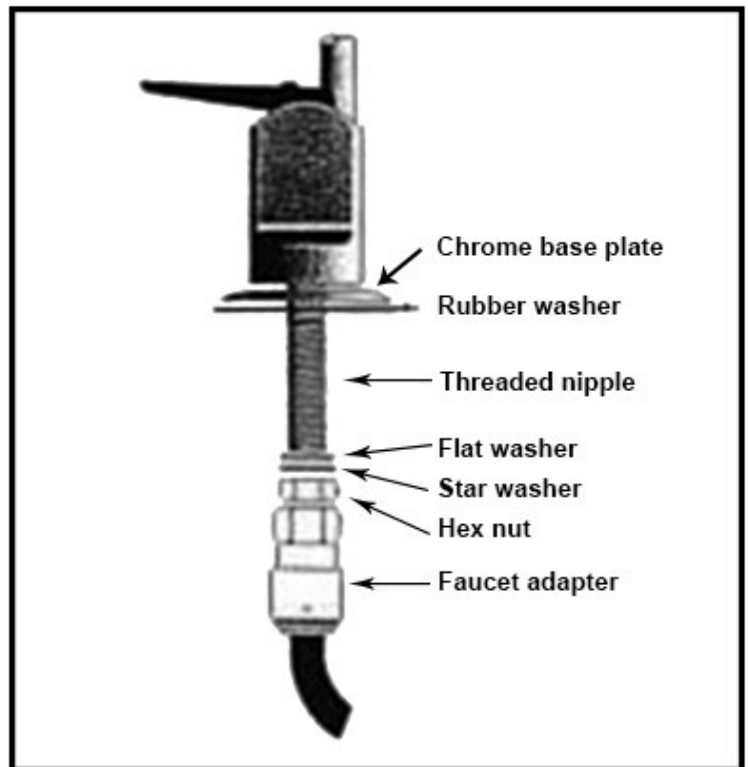

Faucet Installation without air gap

Installation Instructions

Residential Reverse Osmosis Drinking Water System

B. Mounting the faucet

1. Install the faucet as shown in Fig. 1 on the previous page. Assistance may be needed to hold the faucet in place while the nut is tightened. Install the finished washer on the faucet.



2. Install the rubber washer on the faucet.



3. Install the plastic sleeve on the threaded rod.



4. Install the brass washer on the threaded rod.



5. Install the brass nut on the threaded rod.



6. Install the faucet in the sink and slide the plastic "U" washer on the bottom of the sink on the faucet.



7. Tighten the nut on the faucet. Be sure the plastic sleeve is in the correct position for the drain line barb connections. The faucet should be held in the correct position when it is tightened to the sink.



Installation Instructions

Residential Reverse Osmosis Drinking Water System



8. Once the faucet is secure, install the 7/16" UNS x 3/8" QC faucet connector on the threaded nipple. This fitting doesn't require sealant. This fitting will seal at the beveled surface. Tighten the fitting hand tight then an additional 1/2



9. Now push the blue tube into the faucet connector. Leave the other end of the blue tube unconnected for now, it will be connected later in the installation.



10. If the air gap portion of the faucet is being used continue to the next steps. Push the 1/4" drain line from the RO module on to the smaller brass barb on the bottom of the faucet. Be sure the tube is completely pushed on the barb or a leak could occur.



10. Now push the supplied piece of 3/8" black tubing on the larger brass barb on the bottom of the faucet. Be sure the tube is completely pushed on the barb or a leak could occur.



C. Feed Water Angle Stop Valve and Tubing Installation



1. To install the angle stop valve, turn off the cold water supply valve for the sink faucet. Open the sink faucet cold water and relieve the pressure. Remove the sink faucet "whip hose" or tubing from the shutoff valve. There will be residual water spilled when this tube is removed. Be sure to have a towel to dry the water that is spilled.



2. Now install the gasket/bushing in the angle stop valve tee.

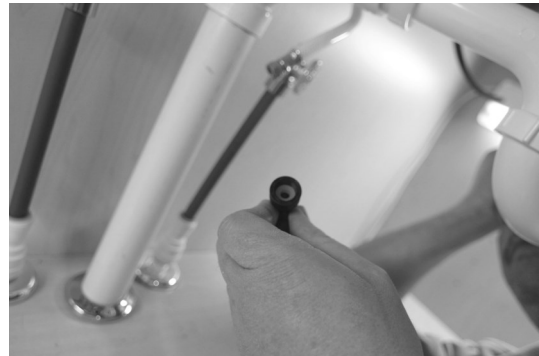
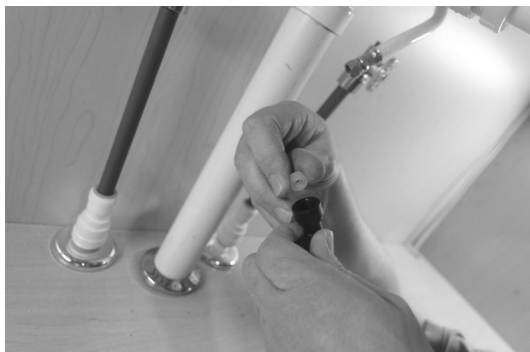

3. Install the tee on the sink faucet shutoff valve and tighten it.



Installation Instructions

Residential Reverse Osmosis Drinking Water System

- Now install the whip hose or tubing on the angle stop valve and tighten.



- Now push the angle stop valve in the tee.



- Push the orange supply tubing in the angle stop valve and install the lock clip. Leave the other end of this tubing unconnected for now, it will be connected later in the installation.



- Be sure the dark gray handle on the angle stop valve is in the closed position. Now open the sink shutoff valve and check the angle stop connections for leaks. If there are leaks repair them now.

D. Drain Saddle Installation

Prior to drain saddle installation it is important to inspect the condition of drain pipes to make sure they are not thin and frail. Drain saddle valves are designed to be installed on standard 1-1/2" OD drain pipe. Install the drain saddle valve above the trap (between the sink and trap) and on the vertical or horizontal tailpiece. Never install a drain saddle valve close to the outlet of a garbage disposal or plugging of the RO drain line may result.



Procedures

1. Remove the circle shaped knockout from the gasket.



2. Remove the backing paper and install the gasket on the port side portion of the drain saddle. Be sure the gasket hole is lined up with the port hole.



3. Position the port side of the drain saddle valve at selected location and mark for the opening. Never position the opening at the bottom. A side or top position is recommended.



4. Drill a 3/8" hole at mark through one side of pipe. Be very careful not drill through both sides of the pipe. Applying small amounts of pressure and drilling slowly will help prevent the drill from penetrating both sides of the pipe.



Installation Instructions

Residential Reverse Osmosis Drinking Water System

5. Position both halves of the drain saddle on the drain pipe so both holes are aligned. A screwdriver or drill bit may be used to keep the hole in the pipe and the hole in the drain saddle oriented during the tightening process.
6. Secure the drain saddle clamp on valve with bolts and nuts provided. (Do not over tighten and make sure there is equal space between saddle halves on each side when fully tightened.)

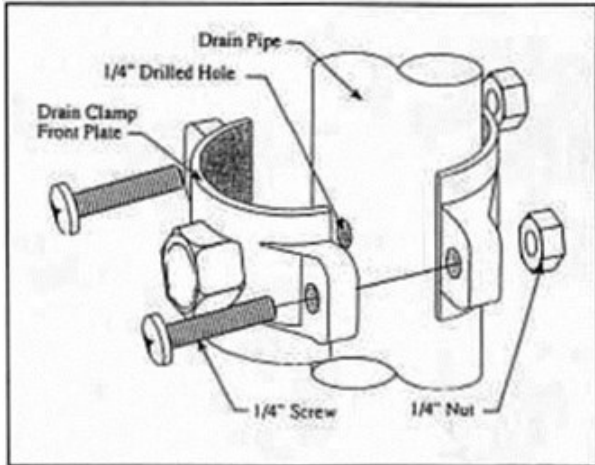

Drain saddle valve installation



7. If the air gap portion of the faucet is being used install the 3/8" black tubing from the faucet to the saddle valve and install the clip. **BE SURE THERE IS A STRAIGHT DROP FROM THE FAUCET TO THE DRAIN SADDLE. A SAG IN THIS TUBING WILL CAUSE A DRAIN WATER BACKUP.**



8. If the air gap portion of the faucet is not used, install the stem reducing fitting to convert the saddle to 1/4" and install the 1/4" black drain line from the RO module into the stem reducer fitting in the drain saddle.



Installation Instructions

Residential Reverse Osmosis Drinking Water System

E. Tank Installation

1. Apply Teflon tape to the Tank outlet threads. About 3-4 wraps will be sufficient.



2. Install the tank valve by turning it clockwise. Tightening it hand tight is usually adequate but additional tightening may be required. Be sure not to overtighten the valve and break the plastic.



3. Once the valve is installed, connect the green 3/8" tubing to the tank valve install the locking clip. Leave the other end of the tubing loose for now, it will be connected later in the installation.

NOTE: Tanks are pre-pressurized at 7 psi. Prior to installation, check, add or release as required.

F. Initial tubing connections

It may be desirable to leave the access tubing when making the final connections. This will allow space to pull the unit out of the cabinet for filter changes without disconnecting all the tubing. If you want to secure the system and cut the tubing to fit that is fine, but this may require that the system be removed for filter changes or the filters will have to be changed with the system in the cabinet which is sometimes difficult.

G. RO Filters and Membrane Installation

1. Install the sediment filter in the first sump. When facing the unit, this would be the far right sump.
2. Remove the first sump from the system and install the sediment filter in the sump.



3. Tighten the far right sump hand tight and secure it with the supplied filter wrench by turning it an additional 1/4 - 1/2 turn.



Installation Instructions

Residential Reverse Osmosis Drinking Water System

4. Remove the center sump and install the carbon filter in the sump. BE SURE that the rubber gasket is in place on BOTH sides of the carbon filter.
6. Remove the far left sump and install the carbon filter in the sump. BE SURE that the rubber gasket is in place on BOTH sides of the carbon filter.



5. Tighten the center sump hand tight and secure it with the supplied filter wrench by turning it an additional 1/4 - 1/2 turn.
7. Tighten the far left sump hand tight and secure it with the supplied filter wrench by turning it an additional 1/4 - 1/2 turn.



Installation Instructions

Residential Reverse Osmosis Drinking Water System

Membrane Installation

1. Remove the 1/4" tubing from the membrane housing cap by pressing the collet on the elbow fitting toward the fitting. When the collet is flush with the fitting, the tubing will pull out of the fitting with little effort. Refer to connections instructions on Page 16.
3. Remove the membrane from the protective packaging and install it in the membrane housing. There are two O-rings on end of the middle membrane tube. Lightly lubricate these O-rings with the supplied silicone grease.

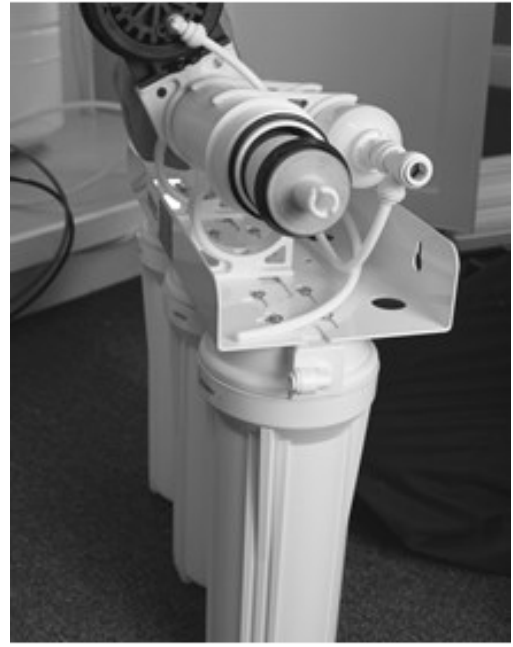

2. Use the supplied wrench to remove the membrane housing cap.
4. **BE SURE** the membrane is fully seated in the housing. If the membrane is fully seated, it will be about 1/8 - 1/4 inset from being flush with the housing.



Installation Instructions

Residential Reverse Osmosis Drinking Water System

5. Lubricate the O-ring on the membrane housing and install the cap hand tight. Tighten the cap an additional 1/8 - 1/4 turn.



6. Push the 1/4" tubing back into the elbow fitting. **BE SURE** it is fully seated in the fitting or a leak could occur.



H. RO unit installation

The RO unit is normally mounted to the sink cabinet sidewall, depending on where supply tank is to be located. Generally the unit is installed at the front of the cabinet and the tank at the rear.

To mount the unit, elevate it at least 2" off the floor, level it and mark the location of mounting holes needed. Drill holes for mounting screws and install screws, allowing the mounting bracket slots to slip over them.

NOTE: If the cabinet sidewalls are not solid, unit may sit on the floor with screws to keep it against the cabinet in a vertical position. The system doesn't have to be secured to the wall but it is a good practice. If the system is not mounted to the cabinet wall and the tubing is not cut short, the module and be removed from the cabinet during filter changes.

I. Final tubing connections

With all components in place, complete final tubing connections using these guidelines:

- Tubing should follow contour of the cabinets.
- Cut tubing to desired length using square cuts or a proper cutting devise.
- Make no sharp bends

Under sink installations following installation diagram and the following procedures:

1. Connect the blue tubing from faucet to RO unit at the post carbon filter outlet fitting.



Installation Instructions

Residential Reverse Osmosis Drinking Water System

2. **BE SURE** the storage tank shutoff valve is in the closed position. Use the supplied syringe and add 5ml of the supplied sanitizing solution to the Green tank tubing attached to the storage tank. Connect the open end of the green tubing from tank to RO unit at the post carbon filter inlet tee fitting. Leave the tank valve closed.



3. Connect orange tubing from the angle stop supply valve to RO unit at the sediment filter inlet fitting.



Permeate Pump Installation

If the system is equipped with a permeate pump, clip the pump to the membrane housing using the supplied mounting bracket and make the connections to the pump using the label on the pump and the labels on the tubing. There will be a Permeate IN, Permeate OUT and Brine IN connection on the pump. The Brine OUT connection will be made in the following step.

4. Connect the tubing from the drain saddle to the RO unit at the flow restrictor on the membrane on a standard system or on the "Brine Out" port on a permeate pump system. If the air gap is being used, connect the black 1/4" line from the faucet to the flow restrictor or to the "brine out" port on the permeate pump.



Icemaker hookup (optional)

The RO drinking water device can be connected to any standard refrigerator ice maker or ice maker/water dispenser. 3/8" tubing must be used for ice maker connections. If your system is using 1/4" tubing for the tank and faucet it will need to be changed to 3/8" tubing. (Do not connect to a commercial type bar ice maker.)

To complete this operation, connect a tee with shutoff valve into the faucet tubing (Blue Line) and route tubing to the refrigerator. (Hooking up to an existing copper line is not recommended as RO water can cause the copper to leach into the water stream). Shut off ice maker prior to turning off the existing tap water supply line to the refrigerator. Connect the RO system tubing to the ice maker inlet. Turn on ice maker after the RO system has been flushed several times and the tank has a full supply of water. There are detailed instructions and a layout drawing on Page # 22 and 23 of the is manual.

NOTE: Before any service is performed on the RO system, turn off ice maker valve and ice maker unit. Turn back on only after RO tank has been flushed and is full of water.

System start-up

Prior to start-up

1. Check all connections to be sure they are secure.
2. Turn on feed water valve and check for leaks. (Turn off and correct leaks if leaks occur.)
3. Close the valve (the tank should be closed from the previous step) on storage tank and open faucet until a steady stream of water flows. Water will be flowing to the drain as well.
4. Once there is a steady stream of water coming from the faucet (about 1/8" in diameter) close faucet and wait five minutes to see if any leaks result on the entire system (The initial water from the system may be discolored. This is normal).

NOTE: BE PATIENT! It is very important that there is a steady stream (not drips) of water coming from the faucet before it is closed. If not, there could be air trapped in the system and it will not fill the tank properly. This can waste a lot of water.

5. If there are no leaks, open the storage tank valve allow the system to fill. Most systems will be full within 2 hours. The system is full when the water to the drain stops. Check for leaks with the system full and repair them accordingly.

NOTE: When the system is first turned on, water may intermittently "spurt" from the air gap opening on the side of air gap faucets. This is common and should correct itself after the air is purged from the system.

Flushing system and checking operation

To make sure RO system is operating correctly, follow these simple procedures:

1. Open faucet handle and allow tank to completely drain (water will be discolored and will have suds from the sanitizing solution).
2. Close faucet and re-fill the system.
3. Allow system to process water for approximately 2-3 hours, at which point tank will be practically full.
4. Open faucet again and allow tank to empty for a second time. Do not use this water.
5. Wait another 2-3 hours to allow tank to re-fill.

Air Purging

If the tank doesn't fill, the tank tubing may have air in it. Typically the standard startup procedure will be sufficient but in some cases due to the water temperature and pressure, additional air bleeding must be performed. The following procedure will help bleed air from the system.

1. Close the tank valve and the feed water valve and open the faucet to relieve the pressure on the system.
2. Remove the tank tubing from the tank valve and hold it over a bucket or pan.
3. Open the feed water valve and the faucet.
4. Allow the system to run until there is a stream of water coming from the tank tubing.
5. Once there is a steady stream coming from the tank tubing, push it back into the tank valve. BE SURE to push it in the tank valve completely or a leak could occur.
6. Allow the system to continue to operate until there is a steady stream coming from the faucet.
7. Once there is a steady stream coming from the faucet, close the faucet and open the tank valve. Then go to the flushing procedure above.

NOTE: If no objectionable tastes are noticed after second tank draining, RO processed water is ready for use. Otherwise, drain tank and re-fill for a third time.

At this point supply line to ice maker connection (optional) may be opened.

Maintenance

The RO system contains filters and membranes which must be replaced periodically for proper operation.

Replacement part	Frequency
Pre-filter (sediment)	Every 6-12 months.
Pre-filters (activated carbon)	Every 6-12 months.
R/O membrane	Every 3-5 years
Post filter (carbon)	Every 6-12 months.

NOTE: Filter change frequencies may be amended, depending on source water conditions.

Sanitizing Filter Change Instructions

- Turn off the feed water to the system and shut-off the icemaker power and water supply valve (if applicable).
- Turn on the faucet to relieve any pressure on the system and make sure water has stopped flowing out of the faucet.
- Remove the membrane and all the lower vertical sump filters. The post carbon filter can be left in place at this time. Use rubber gloves and store the membrane in water or a Ziploc bag to prevent damage or discard the membrane if it is being replaced.
- Use the included plastic syringe to collect 5ml of Sani-System solution from the packet and set aside. Pour the remainder of the packet of Sani-System directly into the sediment filter housing (where inlet feed line attaches). Reattach all filter housings and membrane caps. Do not install the filters at this time. Remove the tube that connects to the storage tank from the RO module and invert it to remove the water from the tube. If you have a fitting with a nut, disconnect it. If the fitting is a quick-connect type (push-to-fit) then you just push in the locking collet and pull the tube out. Inject all of the Sani-System solution from the plastic syringe into the line. Reattach tank tube. Make sure RO water faucet is closed and turn on water supply.
- Allow system to fill with water. The time will vary depending on the water pressure. However, the system should be full within 5 – 10 minutes without the filters or membrane. Allow system to rest for 10 minutes. Open faucet and allow to drain for 10 minutes then close faucet. Allow the system to fill and rest for another 10 minutes, then open faucet again and allow system to flush for another 10 minutes. Shut off inlet supply and open faucet to depressurize the system. Remove the sumps and install the filters and membrane.
- The white fiber-type filter is installed in the INLET (sediment) filter sump. Lubricate the o-ring at the top of the sump with a small amount of the silicone included. Tighten the filter sump hand tight, then using

- the wrench, turn an additional ¼ turn, but do not over tighten.
- The carbon block filter(s) are installed into the next sump (for 3 & 4-Stage) or the next two sumps (for 5-Stage). Lubricate the O-ring at the top of the sump with a small amount of the silicone included. Be sure the rubber gaskets are in place on both sides of the carbon block filter. Tighten the filter sump hand tight, then using the wrench, turn an additional ¼ turn, but do not over tighten.
 - The inline filter is installed on the top of the membrane (does not apply on 3-Stage systems). The fittings in each end of the old post filter must be removed and wrapped with a couple of layers of ½" Teflon tape around the fitting (when looking at the threaded side of the fitting, always wrap the Teflon tape in a clockwise manner). The tee fitting will screw into the inlet side of the new filter and the elbow fitting to the outlet side. Re-install the tubing and make sure everything is sealed.
 - Turn on feed water valve and check for leaks. (Turn off and correct leaks if leaks occur.)
 - Close the valve on storage tank and open faucet until a steady stream of water flows. Water will be flowing to the drain as well.
 - Once there is a steady stream of water coming from the faucet (about 1/8" in diameter) close faucet and wait five minutes to see if any leaks result on the entire system (The initial water from the system may be discolored. This is normal).

NOTE: BE PATIENT! It is very important that there is a steady stream (not drips) of water coming from the faucet before it is closed. If not, there could be air trapped in the system and it will not fill the tank properly. This can waste a lot of water.

- If there are no leaks, open the storage tank valve allow the system to fill. Most systems will be full within 2 hours. The system is full when the water to the drain stops. Check for leaks with the system full and repair them accordingly.

NOTE: When the system is first turned on, water may intermittently "spurt" from the air gap opening on the side of air gap faucets. This is common and should correct itself after the air is purged from the system.

Flushing system and checking operation

To make sure RO system is operating correctly, follow these simple procedures:

1. Open faucet handle and allow tank to completely drain (water will be discolored and will have suds from the sanitizing solution).
2. Close faucet and re-fill the system.
3. Allow system to process water for approximately 2-3 hours, at which point tank will be practically full.
4. Open faucet again and allow tank to empty for a second time. Do not use this water.
5. Wait another 2-3 hours to allow tank to re-fill.

Air Purging

If the tank doesn't fill, the tank tubing may have air in it. Typically the standard startup procedure will be sufficient but in some cases due to the water temperature and pressure, additional air bleeding must be performed. The following procedure will help bleed air from the system.

1. Close the tank valve and the feed water valve and open the faucet to relieve the pressure on the system.
2. Remove the tank tubing from the tank valve and hold it over a bucket or pan.
3. Open the feed water valve and the faucet.
4. Allow the system to run until there is a stream of water coming from the tank tubing.
5. Once there is a steady stream coming from the tank tubing, push it back into the tank valve. BE SURE to push it in the tank valve completely or a leak could occur.
6. Allow the system to continue to operate until there is a steady stream coming from the faucet.
7. Once there is a steady stream coming from the faucet, close the faucet and open the tank valve. Then go to the flushing procedure above.

NOTE: If no objectionable tastes are noticed after second tank draining, RO processed water is ready for use. Otherwise, drain tank and re-fill for a third time.

At this point supply line to ice maker connection (optional) may be opened.

Why the regular use of Sani-System is important.

A reverse osmosis system should be sanitized regularly to maintain quality service levels. If the system is not properly maintained, bacteria can begin to grow and multiply wherever the water sits, including on the inside surfaces of tanks and hoses. Filling the system with impure water can also be a cause, but over time, bacteria grows — even in chlorinated water. When water sits in a tank or hose, chlorine levels drop, reducing its chemical ability to prevent bacterial growth. Filters can also filter out chlorine, making the water more susceptible to bacterial growth. In addition, system equipment such as hoses, filters and canisters can harbor and help to support bacterial growth.

Sani-System is the only EPA & NSF approved sanitizer for use in reverse osmosis units. It is proven to kill 99.9% of harmful bacteria without the use of chlorine, oxidizers or acids that can harm system parts. Sani-System maintains the performance of your reverse osmosis system and restores it to peak efficiency.

Water quality

Water quality from an RO system is normally determined with a TDS Meter, which measures total dissolved solids in water, measuring conductivity. The results are normally measured in parts per million or milligrams per liter. Fewer dissolved solids results in higher quality water.

RO membranes are rated by the amount of dissolved solids they reject expressed as “rejection percentage”.

For example:

If feed water contains 100 ppm of dissolved solids and the product water after the membrane has 10 ppm of dissolved solids the rejection rate is 90%.

The formula is as follows:

$$\text{Percent Rejection} = \frac{(\text{Feed H}_2\text{O TDS} - \text{Product H}_2\text{O TDS}) \times 100\%}{\text{Feed H}_2\text{O}}$$

RO membranes should operate between an 80-97% rejection rate. Once the rejection falls below 80%, the membrane must be replaced.

Water production

PRODUCT WATER RATE

Usable water production from an RO system is designated **product water rate**, produced on a daily basis. The rate is normally described in gallons per day (gpd) or milliliters per minute (ml/min).

REJECT WATER RATE

The flow of water to drain is designated as **reject water rate**, as measured in gallons per day (gpd) or milliliters per minute (ml/min).

Using a graduated cylinder the formulas are:

Milliliters per minute x 0.38	= gallons per day
Ounces per minute x 11.2	= gallons per day

REJECT RATIO

The **reject ratio** is the amount of water produced compared to the amount of water flowing to drain.

The formula is as follows:

Reject Ratio =

$$\frac{\text{Reject Rate}}{\text{Product Rate}}$$

PERCENT RECOVERY

The **percent recovery** is another way to measure the amount of water produced compared to the amount of water which is actually used.

The formula to determine percent recovery is as follows:

Percent Recovery =

$$\frac{\text{Product H}_2\text{O Rate} \times 100\%}{\text{Feed H}_2\text{O Rate}}$$

NOTE: Product water rate is the sum of the feed water flow rate and reject water flow rate.

For example:

Product water rate	= 10 gpd
Reject water rate	= 40 gpd
Feed water	= (10 gpd + 40 gpd) or 50 gpd
Percent Recovery	= 20%

Water pressure and temperature

Product water quality and production of RO systems is dependent on pressure and temperature. Typically, RO membranes are treated at standard conditions of 77°F (25°C) and 60 psi (4 bar) discharging to atmosphere. In general, the higher the pressure differential and temperature, the greater the quality and quantity of water produced. These factors should be considered when sizing RO systems for a particular application.

Quick connect fittings

Many RO systems utilize Quick Connect fittings. These user-friendly fittings provide superior performance and may be provided with this system. Proper use of these push-in fittings is shown below. Along with these fittings, all tubing selected must be of high quality and must be cut with a plastic tube cutter or sharp razor with a clean, square cut.

How to make a connection:

1. Cut the tube square

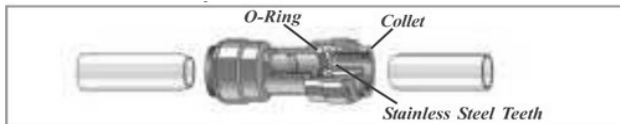

Cut the tube square. It is essential that the outside diameter be free from score marks and that burrs and sharp edges be removed before inserting into fitting. For soft thin walled tubing we recommend the use of tube inserts.

2. Insert tube



Fitting grips before it seals. Ensure tube is pushed fully into the tube stop.

3. Push up to the tube stop



Push the tube into the fitting to the tube stop. The collet (gripper) has stainless steel teeth which hold the tube firmly in position while the O-ring provides a permanent leak proof seal.

4. Pull to check secure



Pull on the tube to check that it is secure. It is a good practice to test the system prior to leaving the site and/or before use.

Disconnecting

Push in Collet and remove tube



To disconnect, ensure the system is depressurized before removing the tube. Push in collet squarely against face of fitting. With the collet held in this position, the tube can be removed. The fitting can be re-used.

Should a leak occur at a fitting, the cause is generally defective tubing. To fix a leak, relieve pressure, release tubing, cut off at least 1/4" from the end (square cut), reattach the tubing and confirm the connection is leak free. Each time a new connection is made, it is advisable to cut off 1/4" from the end of the tubing using these fittings.

US Water American Revolution 5-Stage RO System

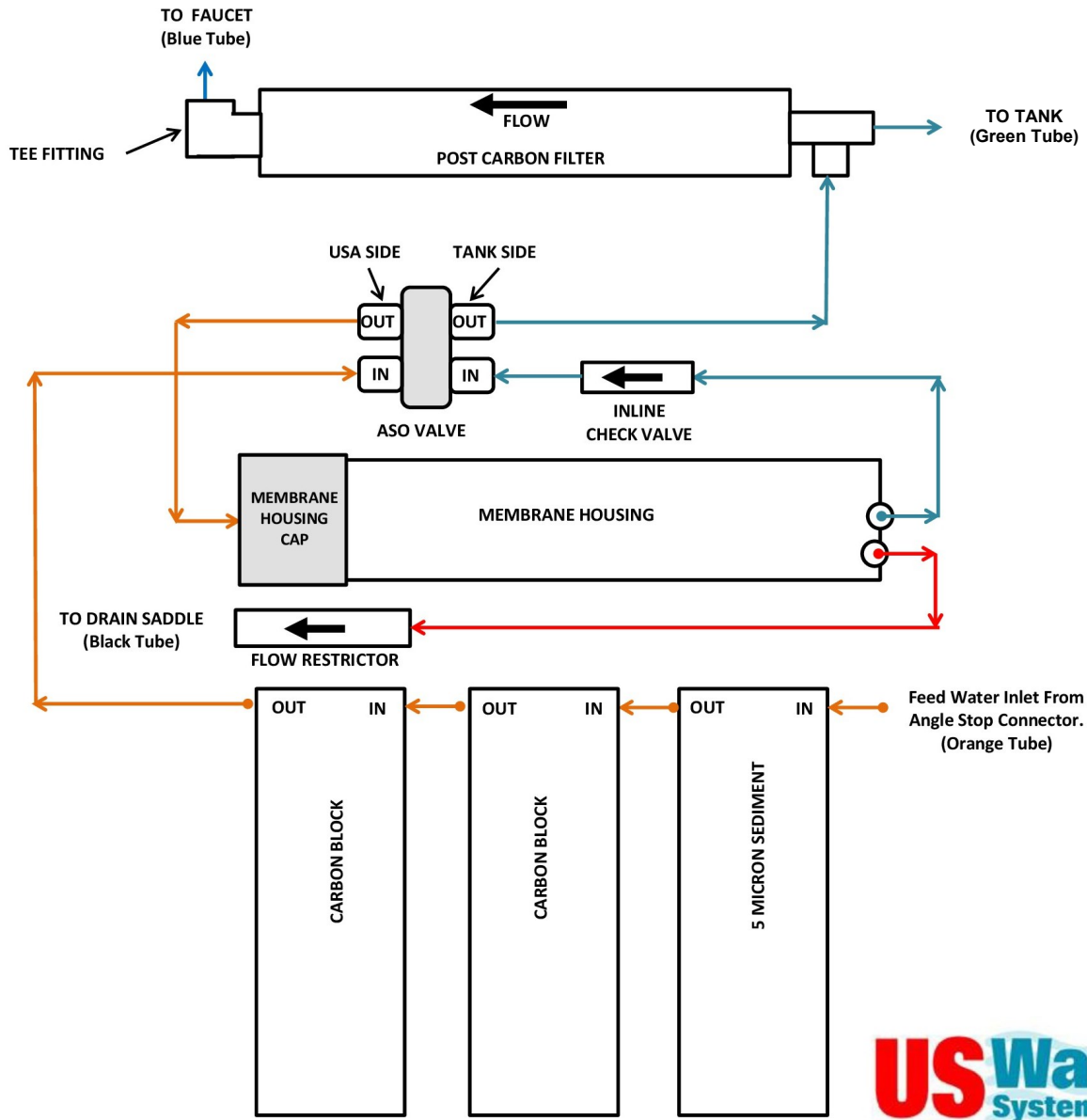

US Water Systems American Revolution RO System Flow Schematic	No Scale		Drawn by: C. Dietz	June 22, 2014
---	----------	--	--------------------	---------------

Ice Maker Kit Installation Instructions

1. Cut the 3/8" line that goes to the faucet and insert the 3/8" tee fitting.
2. Attach the 3/8" tubing that came with the kit to the open port on the tee.
3. Cut this tube about 2" after the 3/8" tee. Insert the shut off valve.
4. Attach the remaining 3/8" tubing to the other end of the valve.
5. Now run the 3/8" tubing to the refrigerator/ice maker close to the water inlet solenoid.
6. Once the tubing is routed to the refrigerator/ice maker, use the 3/8" to 1/4" adaptor to the existing 1/4" tubing on the refrigerator/ice maker or use the 7/16" x 3/8" water inlet solenoid adaptor. If the solenoid adaptor is used, remove the 1/4" existing line nut and sleeve, then screw the adaptor to the water inlet solenoid. No sealant or Teflon tape is required for solenoid adaptor. It is a compression fitting. Tighten the fitting and insert the 3/8" tubing. Leave the ice maker off until the RO system is flushed and full.
7. When the RO system is full, turn on the ice maker shutoff valve and the ice maker shutoff lever or switch.
8. Disregard the first two batches of ice. This will flush the internal tubing in the ice maker or refrigerator.
9. If there is a filter in the refrigerator or ice maker be sure to bypass it or make sure it is change annually with the RO system filter.

Flow Schematic is on the next page.

Installation Instructions

Residential Reverse Osmosis Drinking Water System

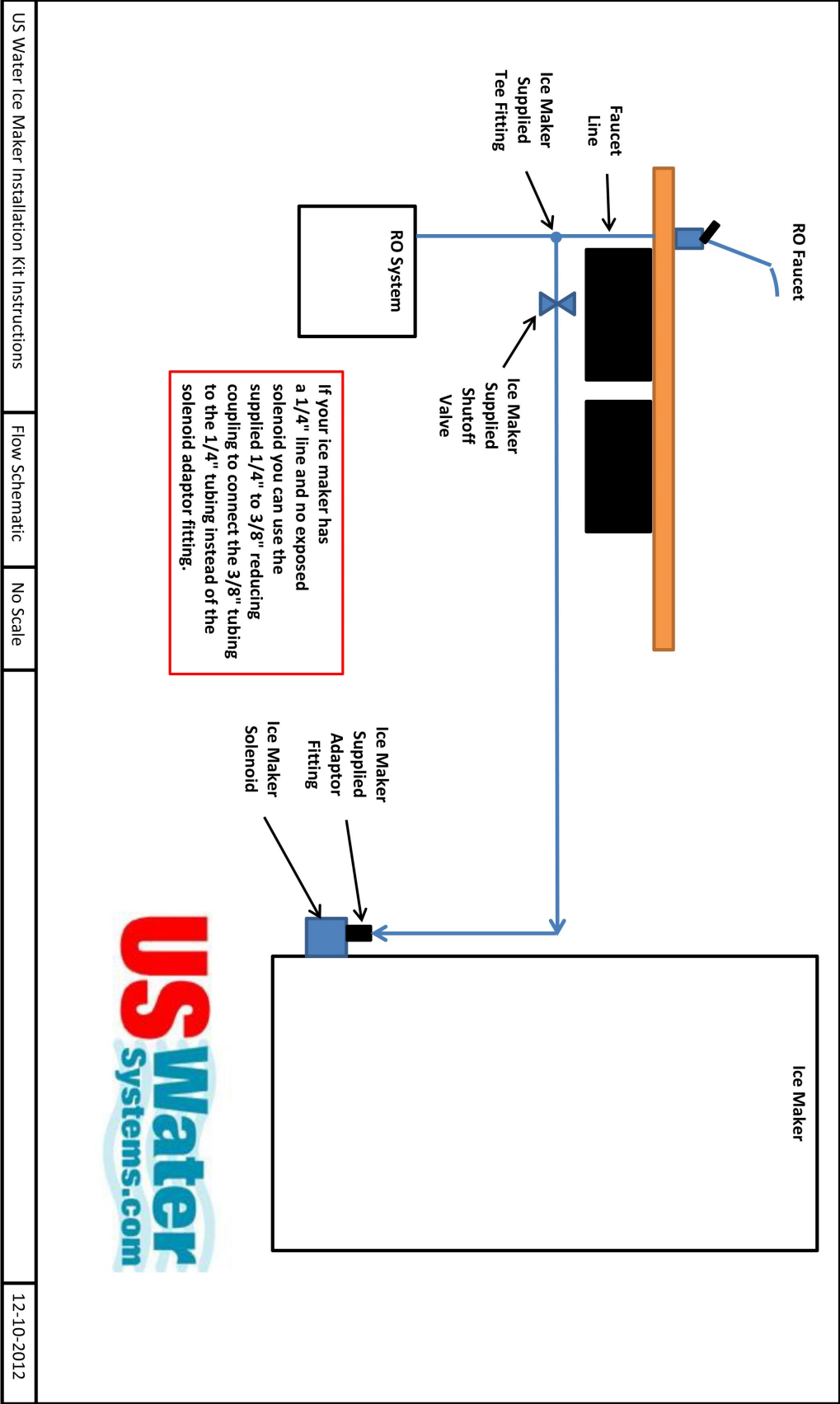

US Water Ice Maker Installation Kit Instructions

Flow Schematic

No Scale

12-10-2012



AMERICAN REVOLUTION 5 STAGE

FIVE YEAR COVERAGE

For five (5) years to the original purchaser, at the original residential place of installation of this *American Revolution 5 Stage* Series Reverse Osmosis Drinking Water Purification System, *US WATER SYSTEMS, INC.* warrants the following:

**Storage Tank
RO Module**

Free of all costs to you except transportation and labor charges, we warrant that we will replace or repair the storage tank, filter housings, and membrane housing, if for any reason it is found to be defective, because of faulty materials or workmanship.

ONE YEAR COVERAGE All Other Parts

We warrant that for one (1) year from the date of installation, we will replace any part not listed above at no charge to you except for transportation and standard labor charges, except the following items:

**Pre Filters
Post Filter
Reverse Osmosis Membrane**

AMERICAN REVOLUTION PERMEATE PUMP SYSTEM

FIVE YEAR COVERAGE

For five (5) years to the original purchaser, at the original residential place of installation of this *American Revolution Permeate Pump Series* Reverse Osmosis Drinking Water Purification System, *US WATER SYSTEMS, INC.* warrants the following:

**Storage Tank
RO Module**

Free of all costs to you except transportation and labor charges, we warrant that we will replace or repair the storage tank, filter housings, and membrane housing, if for any reason it is found to be defective, because of faulty materials or workmanship.

ONE YEAR COVERAGE All Other Parts Including Permeate Pump

We warrant that for one (1) year from the date of installation, we will replace any part not listed above at no charge to you except for transportation and standard labor charges, except the following items:

**Pre Filters
Post Filter
Reverse Osmosis Membrane**

GENERAL PROVISIONS

This warranty does not apply to any commercial or industrial installations or to any part of the reverse osmosis system which has been subjected to misuse, neglect, alteration or accident; or to any damage caused by fire, flood, freezing, Acts of God, or any other casualty, or if said system is damaged by anyone, or if the original serial numbers have been removed. Fouling or damage to the membrane or filters caused by iron, sulfur, bacterial iron, silt, sand, tannins, organics, bacteria, hot water or chlorine voids the warranty on the membrane..

These warranties are in lieu of all other warranties expressed or implied, and we do not authorize any person to assume for us any other obligation on the sale of this water conditioner. No responsibility is assumed for delays or failure to meet these warranties caused by strike, government regulations or other circumstances beyond the control of *US WATER SYSTEMS, INC.*

TO OBTAIN WARRANTY SERVICE, CALL OR WRITE: *US WATER SYSTEMS, INC.* 1209 COUNTRY CLUB ROAD INDIANAPOLIS, IN 46234 (317) 209-0889 OR 800-608-8792.

ANY IMPLIED WARRANTIES OF FITNESS OR MERCHANTABILITY ARE LIMITED TO THE TERMS OF THIS

EXPRESSED WARRANTY AND THERE ARE NO WARRANTIES WHICH EXTEND BEYOND THOSE HEREIN. *US WATER SYSTEMS, INC.* SHALL NOT BE LIABLE WHATSOEVER FOR ANY INCIDENTAL AND/OR CONSEQUENTIAL DAMAGES.

SOME STATES DO NOT ALLOW THE EXCLUSION OR LIMITATIONS OF INCIDENTAL OR CONSEQUENTIAL DAMAGES SO THE ABOVE LIMITATION MAY NOT APPLY TO YOU. THIS WARRANTY GIVES YOU SPECIFIC LEGAL RIGHTS, AND YOU MAY ALSO HAVE OTHER RIGHTS WHICH VARY FROM STATE TO STATE.

THIS WARRANTY MAY BE TRANSFERRED TO A SUBSEQUENT OWNER WITH WRITTEN APPROVAL OF *US WATER SYSTEMS, INC.* AND PAYMENT OF STANDARD TRANSFER FEE.

FOR YOUR RECORDS:

Model _____

Serial _____

Date Installed _____