

Visit us online at  
[www.uswatersystems.com](http://www.uswatersystems.com)

**US Water**  
systems.com

# US Water Systems 1" Fusion NLT Water Softener



**FUSION**  
NLT  
NEXT LEVEL TECHNOLOGY



## Owners Manual

REVISION # 1.1  
REVISION DATE June 27, 2017

US Water Systems Corporate Office  
1209 Country Club Road  
Indianapolis, IN 46234  
[info@uswatersystems.com](mailto:info@uswatersystems.com)  
[www.uswatersystems.com](http://www.uswatersystems.com)  
1-800-608-8792



## Table of Contents

	PAGE
Unpacking / Inspection	2
Safety Guide	2
Proper Installation	3
Specification	4
Before Starting Installation	4
Tank Preparation	6
Installation Instructions	8
Programming	19
Manual Regeneration Steps	21
System Start Up	22
Maintenance	23
Main Repair Parts	24
Warranty	28

## Unpacking / Inspection

Be sure to check the entire unit for any shipping damage or missing parts. Also note damage to the shipping cartons. Contact US Water Systems at 1-800-608-8792 for all damage and loss claims. **A damage claim must be made within 24 hours of receipt of the unit or the claim may not be honored.**

Small parts, needed to install the softener, are in a parts bag. To avoid loss of the small parts, keep them in the parts bag until they are ready to be used.

## Safety Guide

*For general safety, the information in this manual must be followed to minimize the risk of electric shock, property damage or personal injury.*

- Check and comply with the provincial / state and local codes. These guidelines must be followed.
- Use care when handling the softener tank. Do not turn upside down, drop, drag or set on sharp protrusions.
- The system works on 12 volt-60 Hz electrical power only. Be sure to use only the included transformer.
- Transformer must be plugged into an indoor 120 volt, grounded outlet only.
- Use 99.8% pure Solar Salt. Extra-coarse grade or crystals are best but pellets will work too.
- Potassium Chloride may be used in lieu of Sodium Chloride but be sure no one in the household has a medical problem that could be aggravated by a potassium intake.
- **WARNING:** This system is not intended for treating water that is microbiologically unsafe or of unknown quality without adequate disinfection before or after the system.



## Proper Installation

*This water softening system must be properly installed and located in accordance with the Installation Instructions before it is used or the warranty will be void.*

- **Do not** install or store where it will be exposed to temperatures below freezing or exposed to any type of weather. Water freezing in the system will break it. Do not attempt to treat water over 100°F.
- **Do not** install in direct sunlight. Excessive sun or heat may cause distortion or other damage to non-metallic parts.
- Properly ground to conform with all governing codes and ordinances.
- Use only *lead-free solder and flux* for all sweat-solder connections, as required by state and federal codes.
- Maximum allowable inlet water pressure is 125 psi. If daytime pressure is over 80 psi, night time pressure may exceed the maximum. Use a pressure reducing valve to reduce the pressure.
- Softener resins may degrade in the presence of chlorine or chloramines above 2 ppm. If you have chlorine or chloramines in excess of this amount, you may experience reduced life of the resin. In these conditions, you may wish to consider purchasing a whole house carbon filter softener system with a chlorine reducing media. Contact US Water Systems for Chlorine and Chloramine removal equipment.
- **WARNING:** Discard all unused parts and packaging material after installation. Small parts remaining after the installation could be a choke hazard.



## Specifications

Specifications	FNLT-075	FNLT-100	FNLT-150	FNLT-200	FNLT-250
<b>Maximum Capacity New (Not Optimal)</b>	<b>24,000 Grains/12lbs</b>	<b>35,000 Grains/15lbs</b>	<b>53,000 Grains/23lbs</b>	<b>70,000 Grains/30lbs</b>	<b>88,000 Grains/38lbs</b>
<b>Optional Settings - High Efficiency</b>					
Salt Used - Per Regeneration	2.3 lbs	3.0 lbs	4.5 lbs	6.0 lbs	7.5 lbs
Back Wash Override Selection	<b>Without BW/With BW</b>	<b>Without BW/With BW</b>	<b>Without BW/With BW</b>	<b>Without BW/With BW</b>	<b>Without BW/With BW</b>
Water Used - Regeneration	23.2 Gal / 29.2 Gal	32.7 Gal / 40.7 Gal	45.8 Gal / 57.8 Gal	44.7 Gal / 58.7 Gal	60.1 Gal / 80.1 Gal
Hardness Removal - Grains	11,250	15,000	22,500	30,000	45,000
<b>Factory Settings - Standard Capacity</b>					
Salt Used - Per Regeneration	4.5 lbs	6.0 lbs	9.0 lbs	12.0 lbs	18.0 lbs
Back Wash Override Selection	<b>Without BW/With BW</b>	<b>Without BW/With BW</b>	<b>Without BW/With BW</b>	<b>Without BW/With BW</b>	<b>Without BW/With BW</b>
Water Used - Regeneration	25.3 Gal / 31.3 Gal	36 Gal / 44 Gal	50.3 Gal / 62.3 Gal	48.9 Gal / 62.9 Gal	64.5 Gal / 84.5 Gal
Hardness Removal - Grains	18,750	24,600	36,900	49,200	61,500
<b>Optional Settings - High Capacity</b>					
Salt Used - Per Regeneration	7.5 lbs	12.0 lbs	18.0 lbs	24.0 lbs	30.0 lbs
Back Wash Override Selection	<b>Without BW/With BW</b>	<b>Without BW/With BW</b>	<b>Without BW/With BW</b>	<b>Without BW/With BW</b>	<b>Without BW/With BW</b>
Water Used - Regeneration	28.8 Gal / 34.8 Gal	40.8 Gal / 48.8 Gal	56.8 Gal / 68.8 Gal	55.3 Gal / 69.3 Gal	71.4 Gal / 91.4 Gal
Hardness Removal - Grains	22,500	30,000	45,000	60,000	75,000
Resin Quantity - Cubic Feet	0.75 CU/FT	1.0 CU/FT	1.5 CU/FT	2.0 CU/FT	2.5 CU/FT
Tank Size	8X44	9X48	10X54	12X52	13X54
Tank Jackets	Yes	YES	YES	YES	YES
Brine Tank/Cabinet Size (Inches)	15X17X35	15X17X35	15X17X35	15X17X35	15X17X35
Salt Storage Capacity	240 lbs	240 lbs	240 lbs	240 lbs	240 lbs
Flow Rate @ 15 PSI Pressure Drop	10 gpm	11.0 gpm	11.2 gpm	12.2 gpm	12.6 gpm
Flow Rate @ 25 PSI Pressure Drop	14 gpm	15 gpm	15.1 gpm	16.2 gpm	16.6 gpm
Peak Flow Rate	7 gpm	10 gpm	15 gpm	20 gpm	25 gpm
Back Wash Flow Rate	1.5 gpm	5 gpm	5 gpm	7 gpm	10 gpm
Plumbing Connections	3/4" or 1"				
Resin Type	10 % Cross-Linked Ion Exchange Resin/Carbon				
Electrical Requirements	Input 120V 60 Hz - Output 12V 650mA				
Water Temperature	Min 39 - Max. 100 degrees Fahrenheit				
Water Pressure	Min. 20 - Max. 125 PSI				

- Continuous operation at flow rates greater than the service flow rate may affect capacity and efficiency performance.
- The manufacturer reserves the right to make product improvements which may deviate from the specifications and descriptions stated herein, without obligation to change previously manufactured products or to note the change.
- Peak flow rates are intended for intermittent use only and are for residential application only
- At the stated service flow rates, the service pressure drop through these devices should not exceed 15 psig

## Before Starting Installation

### Tools, Pipe, and Fittings, Other Materials

- Channel Locks
- Screwdriver
- Teflon tape
- Razor knife
- Two adjustable wrenches
- Additional tools may be required if modification to home plumbing is required.
- Plastic inlet and outlet fittings are included with the softener. To maintain full valve flow, 1" pipes to and from the softener fittings are recommended. You should maintain the same, or larger, pipe size as the water supply pipe, up to the softener inlet and outlet.
- Use copper, brass, or PEX pipe and fittings.
- Some codes may also allow PVC plastic pipe.
- ALWAYS install the included bypass valve, or 3 shut-off valves. Bypass valves let you turn off water to the softener for repairs if needed, but still have water in the house pipes.
- 5/8" OD drain line is needed for the valve drain.
- A length of 5/8" OD drain line tubing is needed for the brine tank over flow fitting (optional).
- Extra Course Grade or Crystal water softener



## How the Softener Works

The principle behind water softening is simple chemistry. A water softener contains resin beads which hold electrically charged ions. When hard water passes through the softener, calcium and magnesium ions are attracted to the charged resin beads. The result is removal of calcium and magnesium ions which produces soft water.

This system is controlled with simple, user-friendly electronics displayed on a LCD screen. The main page displays the current time and the remaining gallons in meter mode or the remaining days in calendar clock mode. The system will also scroll through other pertinent information.

## Where To Install The Softener

- Place the softener as close as possible to the pressure tank (well system) or water meter (city water).
- Place the softener as close as possible to a floor drain, or other acceptable drain point (laundry tub, sump, standpipe, etc.).
- Connect the softener to the main water supply pipe BEFORE the water heater. **DO NOT RUN HOT WATER THROUGH THE SOFTENER.** Temperature of water passing through the softener must be less than 100 deg. F.
- Outside faucets and irrigation systems should be supplied with hard water prior to the water softener.
- Do not install the softener in a place where it could freeze. **Damage caused by freezing is not covered by the warranty.**
- Put the softener in a place water damage is least likely to occur if a leak develops. The manufacturer will not repair or pay for water damage.
- A 120 volt electric outlet is needed within 6 feet of the softener. The transformer has an attached 6 foot power cable. **Be sure the electric outlet and transformer are in an inside location, to protect from wet weather.**
- If installing in an outside location, you must take the steps necessary to assure the softener, installation plumbing, wiring, etc. are protected from the elements and contamination sources.
- **Keep the softener out of direct sunlight.** The sun's heat may soften and distort plastic parts.

## Fusion NLT Softener Tank Preparation

**WATER PRESSURE:** A minimum of 30 pounds of water pressure is required for regeneration valve to operate effectively.

**ELECTRICAL FACILITIES:** An uninterrupted alternating current (A/C) supply is required. Note: Other voltages are available. Please make sure the voltage supply is compatible with the unit before installation.

**EXISTING PLUMBING:** Condition of existing plumbing should be free from lime and iron buildup. Piping that is built up heavily with lime and/or iron should be replaced.

**LOCATION OF FUSION TANK AND DRAIN:** The Fusion tank should be located close to a drain to prevent air breaks and back flow.

**BY-PASS VALVES:** Always provide for the installation of a by-pass valve if unit is not equipped with one.

**CAUTION:** Water pressure is not to exceed 80 psi, water temperature is not to exceed 110°F (43°C), and the unit cannot be subjected to freezing conditions.

1. Remove the tank from carton.
2. Verify the distributor tube is centered in the bottom of the tank. A flashlight may be necessary. There is a small indentation in the bottom of the tank that will allow the distributor tube to drop in place. The top of the distributor tube will be flush with the top of the tank when it is installed correctly.

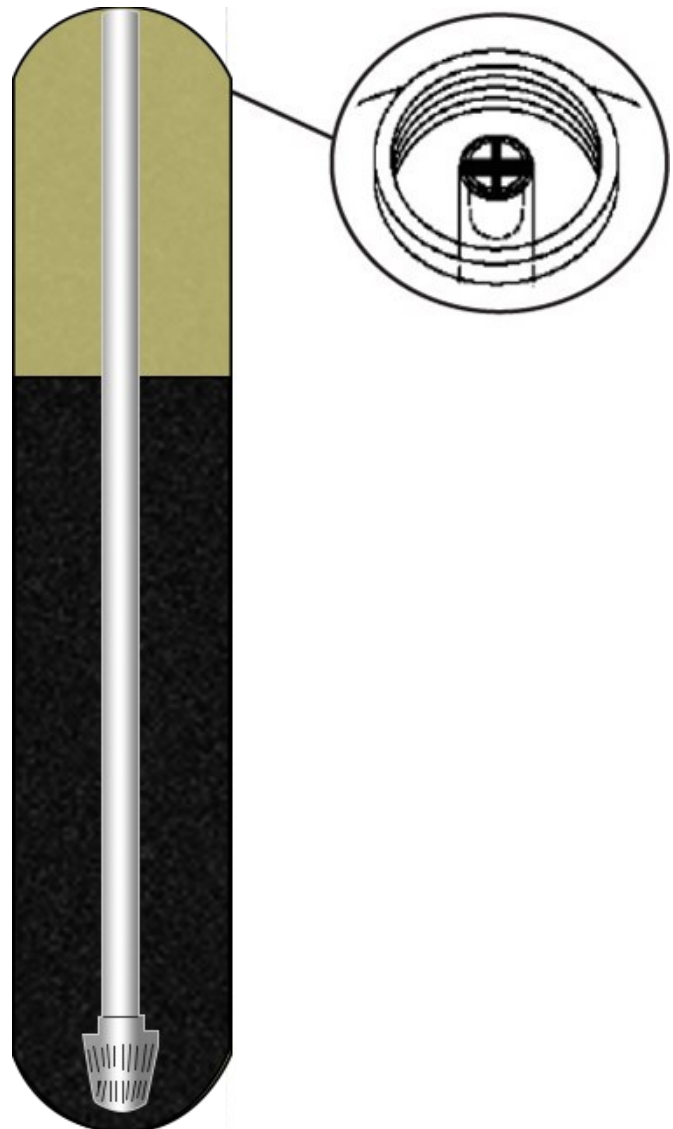

3. Place a piece of duct tape over the distributor tube so no gravel or media enters the opening while filling.

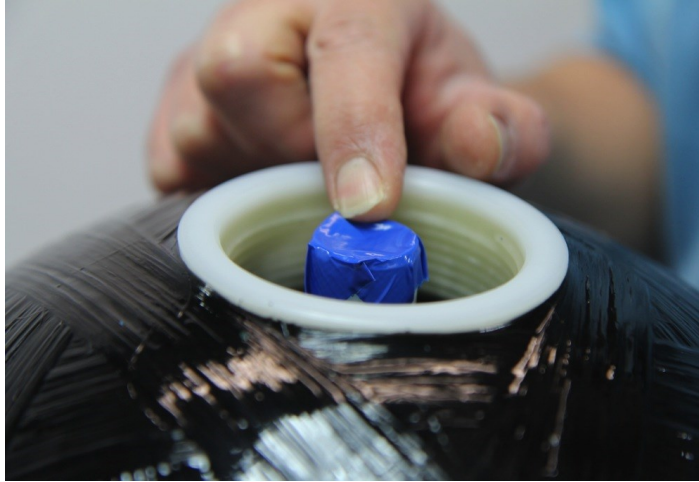

4. Use the Blue Funnel provided, to pour the **RESIN** in the tank. Pour resin evenly around the hole to ensure it is well distributed in the tank. Pour it slow enough, to prevent the funnel from plugging. A helper may be needed to hold the funnel during the filling process. It is recommended that a dust mask and safety goggles be worn to prevent possible injury. A shop vacuum can be held in the area to help control the dust created by the filling process. Pour all the resin that was shipped in the tank. US Water Systems **DOES NOT** ship extra resin.



5. When the resin is installed move tank side to side to settle the media. Remove the funnel and tape from the distributor tube. It is a good practice to fill the tank with water and allow the media to saturate.

6. Lubricate the distributor O-ring and the tank O-ring on the bottom of the control valve. Then install the upper basket on the bottom of the valve by lining up the tabs then turning the basket clockwise to lock it in place. Place the upper basket over the distributor tube and push the valve on the tank. Thread the valve on the tank by turning it clockwise. **Be sure** not to cross-thread the valve on the tank. Tighten the valve hand tight, then snug it further by tapping it with the palm of the hand on the pipe connection side of the valve. **DO NOT** use tools to tighten the valve or damage could occur.

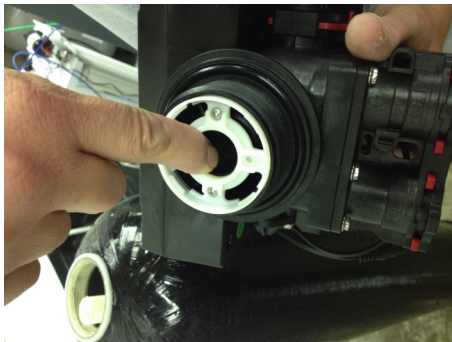



7. Lubricate the O-rings on the bypass valve and 1" threaded connectors. Remove the red clips and install the bypass on the control valve. Re-install the red clips once the bypass is in place. Put the bypass valves in the bypass position (picture shows "Service Position", see page 18 for valve position)

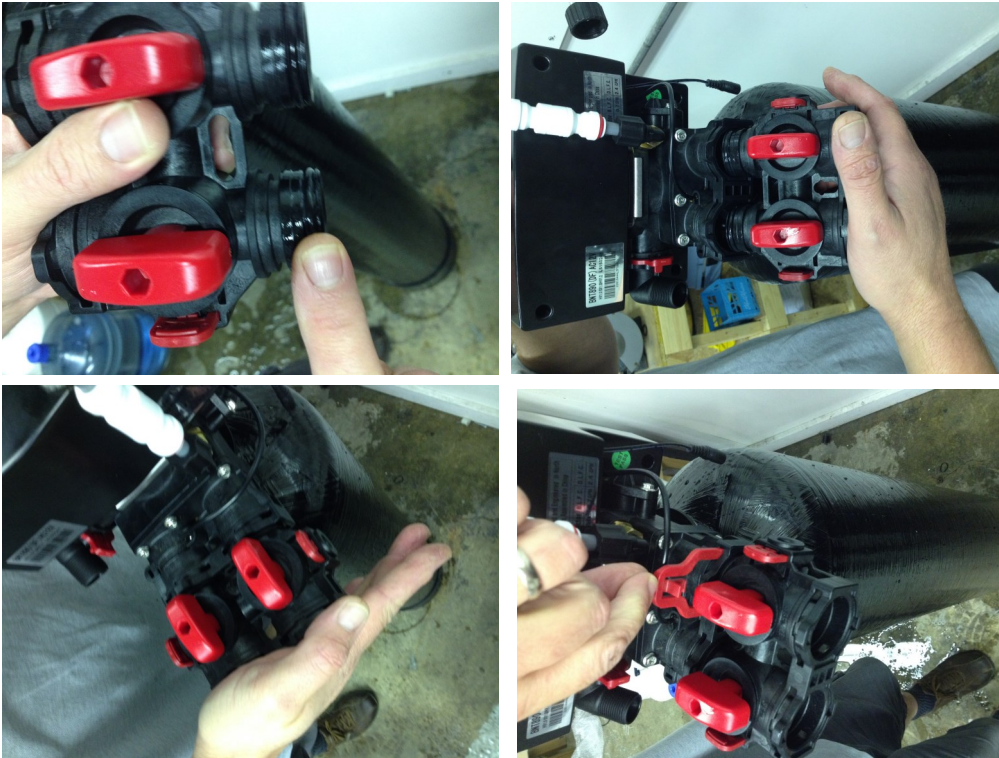

8. Apply Teflon tape to the 1" connectors. Remove the red clips from the previously installed bypass and install the 1" connectors in the bypass valve. Re-install the red clips for the 1" connectors.



**Note:** As the picture shows, connect the inlet and outlet according to the arrow direction which can be seen from the top view of the control valve.

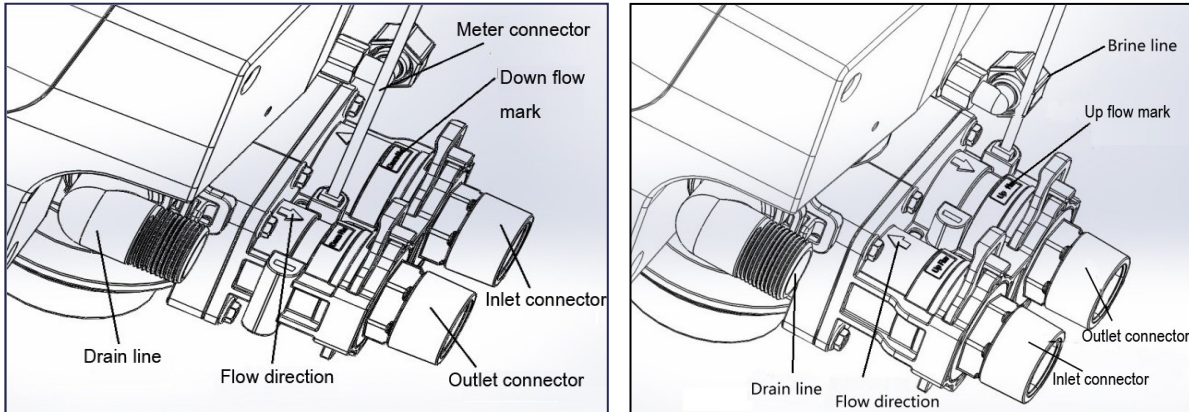

**The installation of 1" integrated bypass valve:**

If the 1" integrated bypass is used instead of a three manual valve, the installation method is shown in the picture below.

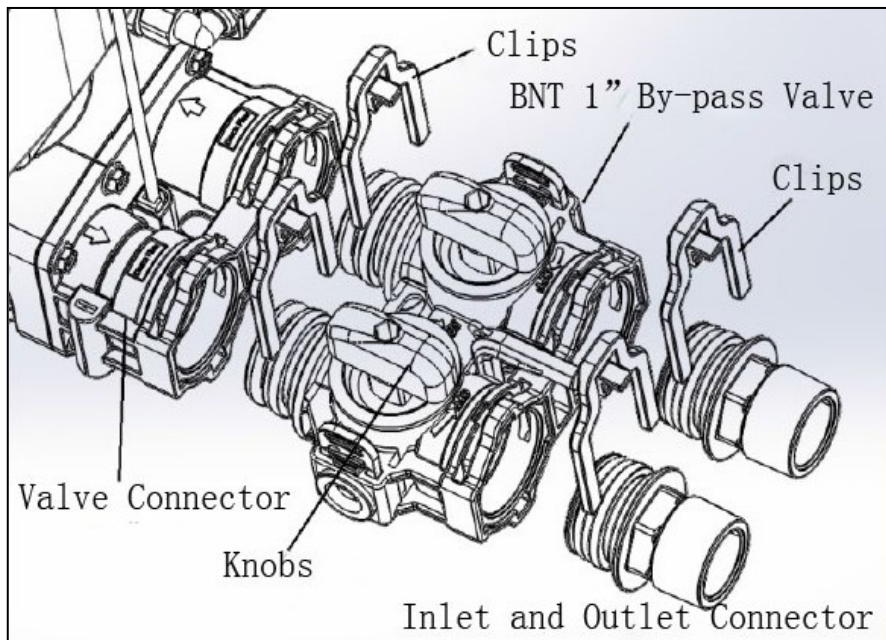



9. Install the Fusion system close to the water source. **BE SURE** to install the Fusion system directly after the well pressure tank. It is a good practice to add a sediment filter prior to the Fusion system between the pressure tank and the Fusion tank. Outside spigots or irrigation should be plumbed in prior to the Fusion system. Shut off the main water supply and relieve the pressure on the plumbing system.
10. Install the inlet plumbing on the inlet side of the control valve and the outlet plumbing on the outlet of the control valve. The inlet and outlet can be identified by the arrows on the control valve. The arrow pointing toward the control valve is the inlet. The arrow pointing away from the control valve is the outlet. (Optional flexible connectors shown utilize rubber washer seals and do not require Teflon tape).

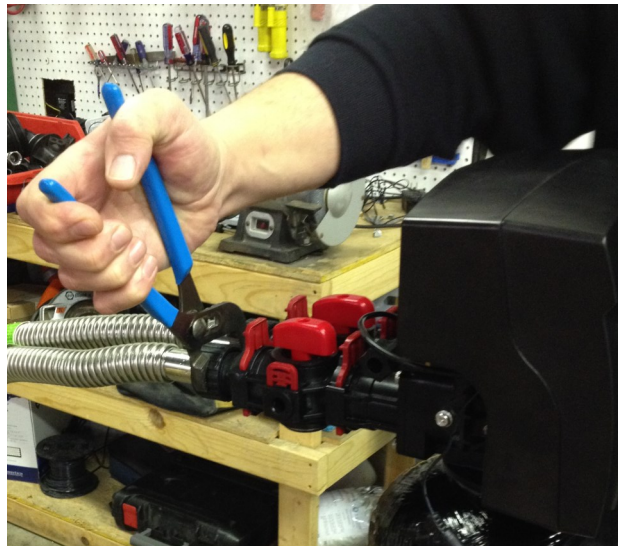
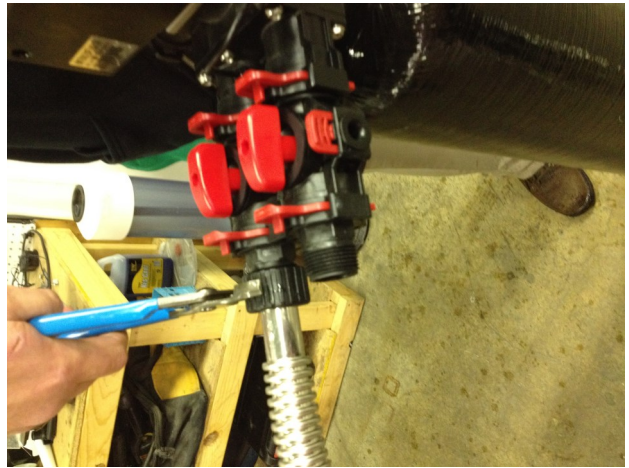

**NOTE:** The Fusion system is equipped with a bypass valve. If a 3 valve bypass in the plumbing system is in place or preferred, the supplied bypass is not required.

11. Install the drain line on the 3/4" threaded elbow. This can be a 3/4" solid pipe conveyed to a floor drain, sink drain or stand pipe or the hose barb fitting can be used to install 1/2" drain tubing. An air gap should be established if the local code requires it. Drain line larger than 3/4" is acceptable. The system will drain with pressure, so the drain line can be ran vertically for up to 5'. If the drain line is ran vertically then along the wall horizontally, make sure the horizontal pipe/tubing has a drop to the final drain point (1" drop per 10' of linear run). The system should be plumbed with the least amount of back pressure on the drain line.



12. The drain elbow can be removed by removing the red clip and pulling the elbow out of the valve. This will make it easier to connect the plumbing fitting used. **BE CAREFUL** not to cross thread the fitting on the elbow. **There is a small thread tolerance for this fitting to help reduce the potential for a leak so it can be cross threaded easily.**



**NOTE:** It may be necessary to install a 3/4" drain line on a linear stretch of drain line that exceeds 15'.

## Installation Instructions

13. Connect the brine line to the control valve by removing the nut on the brine elbow on the control valve and sliding it on the brine line. Then install the line stiffener in the brine line. There is a brass stiffener pre-installed in the line.



14. Push the brine line in the elbow fitting on the control valve until it stops. Then push the nut down on the fitting and tighten it hand tight. Use channel locks to tighten the nut an additional 1/2 turn.



## Installation Instructions

15. Connect the brine line to the control valve by pushing it over the hose barb and installing a clamp to hold it in place.



16. Now connect the brine line to the brine tank safety float assembly. Remove the brine tank lid and the brine well cap. Then push the brine line through the brine tank and brine well.



## Installation Instructions

17. Slide the nut and sleeves over the brine line. Be sure to install the sleeves properly (see pictures below).

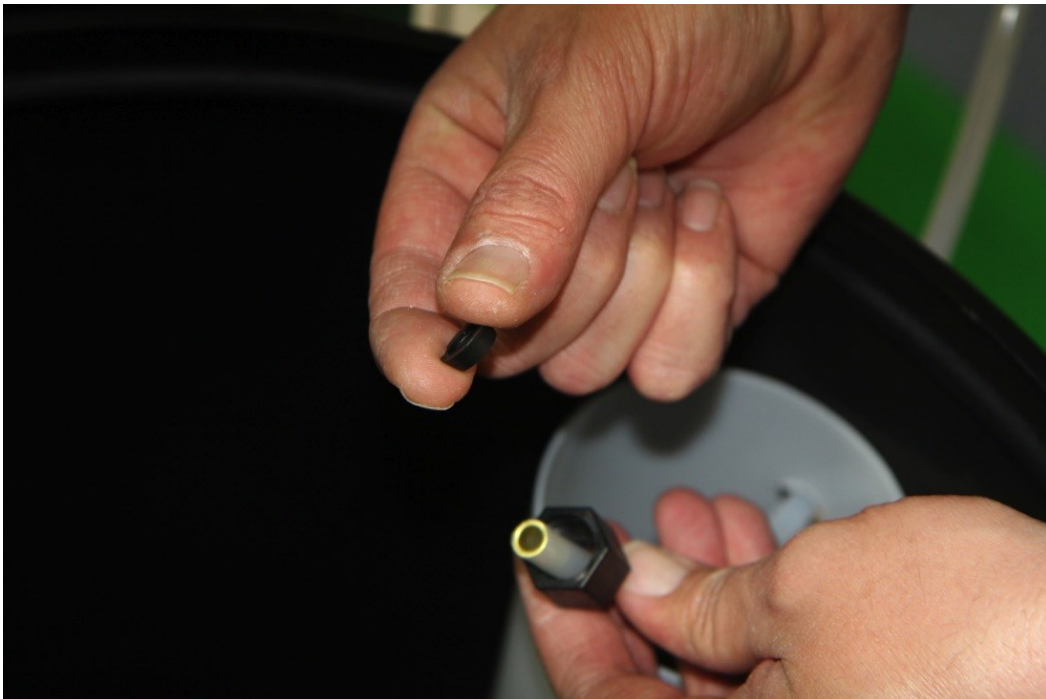

## Installation Instructions





## Installation Instructions

18. Be sure brass stiffener is in the brine tubing, then push the tubing in the elbow. Now tighten the nut by hand. Be sure not to cross thread it. Now tighten it an additional full turn with pliers or channel locks.



1. When the two knobs on the bypass valve are parallel, the inlet and outlet are open, this state of operation is "Service";
2. Rotate each of the two knobs in clockwise and counterclockwise respectively, when the knobs on the bypass is in one line, the inlet and outlet are both closed, this state of operation is "By-pass".

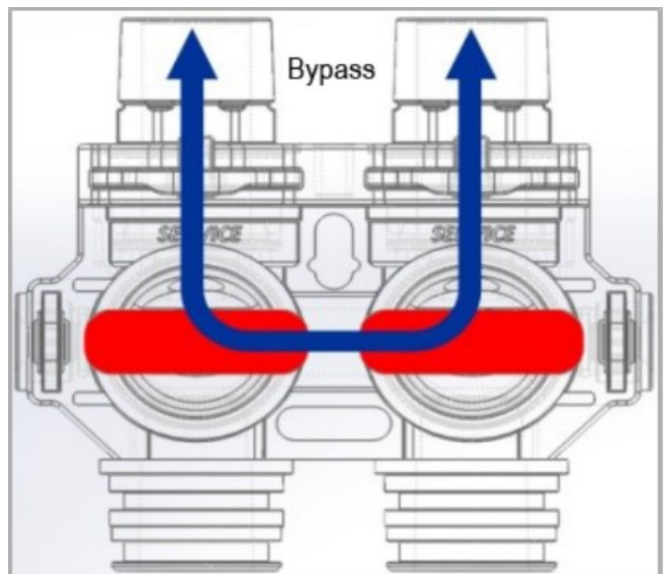
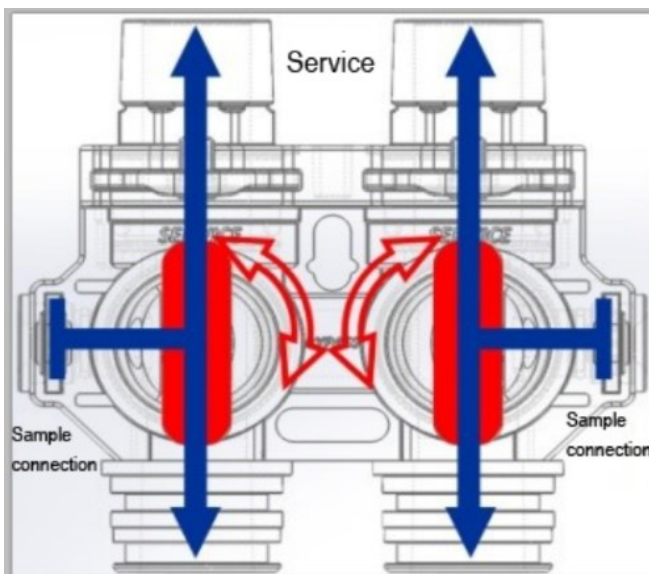

## Button Configuration

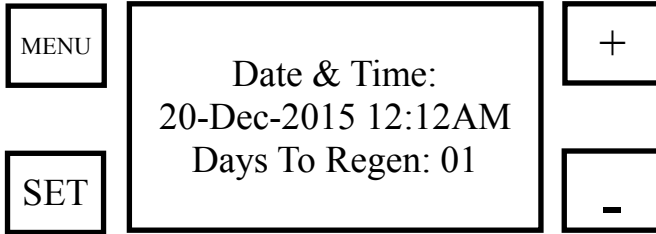

### Key Pad Configuration

MENU	This function is to enter the basic set up information required at the time of installation.
SET	This function is to accept the values if changed and advance to the next page in the menu.
+ / -	These buttons are used to increase or decrease the value of the settings while in the programming mode.

## Programming Levels

There are 3 levels to the valve program. Master options and Factory options are typically adjusted at the factory. These options link the PCB function with the type of control valve and should not be tampered with. Advanced options are used to configure the unit when the valve is assembled to the tank so that it can function as the proper size and intended system operation. Settings are the final options chosen when the unit is installed to a specific location.

PROGRAM LEVEL	USER ACCESS
<b>USER SETTINGS(I)</b>	These settings are programmed when the unit is installed. The settings should only be adjusted by a qualified person.
<b>MAIN MENU (II)</b>	These settings are programmed when the unit is installed. The settings should only be adjusted by a qualified person.
<b>ADVANCED MENU (II)</b>	These settings are programmed by the factory and should be adjusted when the valve is assembled into a unit or system. It contains important settings so the valve will operate properly for the type of system it is intended for. The settings should only be changed by qualified person.
<b>HISTORY MENU (IV)</b>	This menu contains key diagnostics for trouble shooting the system.
<b>FACTORY MENU (V)</b>	These settings are programmed by the factory. The settings are important for the operation of the valve that should only be changed by a qualified person.

The main display page shows the Date, Time Of Day and Days To Remaining and Total Capacity. The display will alternate between the main page and the dealer information page.

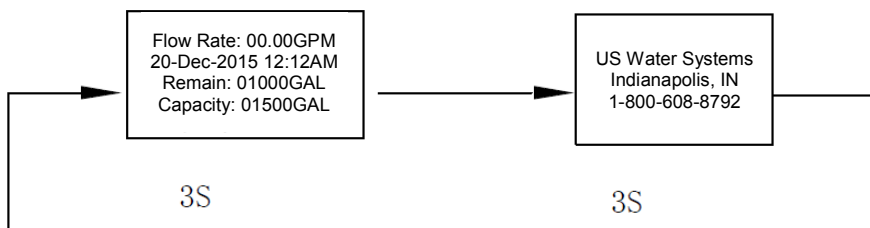



## Programming

Press MENU key.  
 Press + or - to change menu option. Press SET to enter.  
 Press + or - to change value. Press SET to accept.

### Main Menu

To get to the “Main Menu”, press the Menu button to get to the “User Menu”.

- Date & Time Setting
- Hardness
- Manual Regen.
- Dealer Information
- Main Menu

Use the Down arrow to go to “Main Menu” then press and hold the Set button for 5 seconds. This will take the valve to the “Main Menu”.

- =====Main Menu=====
- Regen. Time Setting
  - Regen. Days Setting
  - Advanced Menu

### Main Menu

- =====Main Menu=====
- Regen. Time Setting
  - System Capacity
  - Salt Mode Setting
  - Brine Pre-Fill Set
  - Advanced Menu

Use the “UP or DOWN” arrows to move the cursor over “Regen. Time Setting” and press the “Set” button.

- =====Regen. Time=====
- 2:00 AM
- Press [ ] To Cancel ,
- Press [ ] To Confirm

Use the UP or DOWN” arrows to change the Time to 2:00 AM or a least 1 hour after water usage has stopped for the day. Once the hour value is adjusted, press the “Set” button, then set the minute value, press the “Set” button again, then set the 12 cycle (AM or PM) and press the “Set” button to save the value then press the “Menu” button to confirm the change and return to the “Main Menu”.

- =====Main Menu=====
- Regen. Time Setting
  - Regen. System Capacity
  - Salt Mode Setting
  - Brine Pre-fill Set
  - Advanced Menu

Use the “UP or DOWN” arrows to move the cursor over “Salt Mode Setting” and press the “Set” button.

# Programming

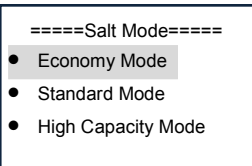

Use the “UP or DOWN” to change the “Mode”. The system is factory set on “Economy Mode”. This is the mode that is used for city/municipal water sources. If there is high hardness levels or if the softener is used to remove iron or other contaminants, the “Standard Mode” should be used. If there are high levels of several contaminants, the “High Capacity Mode” should be used. Once the selection is made, press the “Set” button to save it and then press the “Menu” button to confirm the setting and return to the “Main Menu”. All other settings are factory adjusted and do not need attention.

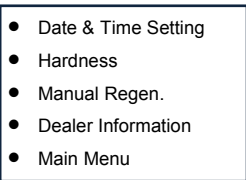

Press the “Menu” button again and return to the “User Menu”.

### User Settings

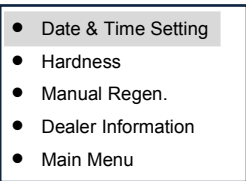

Use the “UP or DOWN” arrows to move the cursor over “Date & Time Setting” and press the “Set” button.

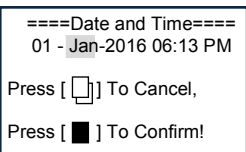

Use the UP or DOWN” arrows to change the day of the month value then press the “Set” button to save it and move to the month. Once the month is entered, press the “Set” button to save it and move to the year. Once the year is entered, press the “Set” button to save it and move to the hour. Once the hour is entered press the “Set” button to save it and move to the minutes. Once the minutes are entered, press the “Set” button to save it and move to the 12 hour cycle selection. Once AM or PM have been entered, press the “Set” button to save it. Then press the “Menu” button to confirm all the settings.

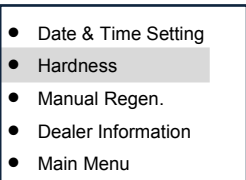

Use the “UP or DOWN” arrows to move the cursor over “Hardness” and press the “Set” button.

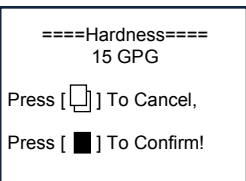

Use the “UP or DOWN” arrows to set the hardness level to 5 GPG above the hardness level for the feed water. If you have iron, take the iron reading in ppm or mg/L and multiply it by 4 and add that value to the hardness level plus the 5 GPG cushion. Press the “Set” button to save it. Press the “Menu” button to return to the main screen.



## Manual Regeneration

### Manual Regeneration

- Date & Time Setting
- Manual Regen.
- Dealer Information
- Main Menu

If the screen is locked, press the "Menu" button for 5 seconds to unlock it. Now press the "Menu" button again to get to the "User Setting". Use the "UP or DOWN" arrow to move the cursor to "Manual Regen" and push the "Set" button.

Regen. Now?
Regen. Tonight?
Press [ ] To Cancel,
Press [ ] To Confirm!

Use the "UP or DOWN" arrow to move the cursor to the desired regeneration type. "Regen. Now" will set the unit into an immediate regeneration. "Regen. Tonight" will set the unit to regenerate at the "Regen. Time" that was selected under the "Main Menu" selection. Once the type of regeneration is selected, press the "Set" button to initiate the regeneration. An immediate (Regen. Now) regeneration will send the valve to the backwash cycle and start the regeneration. A delayed (Regen. Tonight) regeneration is selected, after pushing the "Set" button the "Menu" button must be pressed to confirm the selection. The system will then go back to the home screen and will regenerate at the time selected in the "Main Menu".

## Startup Procedure

1. Be sure the bypass valves are in the “bypass” position (see page 18).
2. Turn on the main water supply and check for leaks in the plumbing.
3. Open a faucet down stream and flush any air from the plumbing. If there are no leaks, move to the next step.
4. Go to the “Salt Mode” setting previously visited and temporarily set it to “Standard Mode”. This will allow a backwash to occur (this can be switched back when the startup is completed). Start an immediate manual regeneration (see previous page). The valve may be locked so the “Menu” button may need to be pushed for 5 seconds to unlock the valve.
5. Once the manual regeneration is started the screen will change. Once the valve reaches the backwash position the time on the screen will begin to count down.

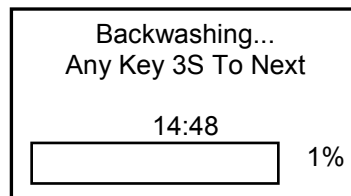

6. When the time is counting down in the backwash position, slowly and slightly open the inlet valve on the bypass open about a 1/4 of a turn. Water will begin to fill the tank.
7. Slowly open the inlet valve in 1/4 turn increments until the valve is completely open and there is a full stream of water coming out of the drain line. If there is a loud “knocking” noise, the valve is being opened to far to fast. Just back the valve off a bit.
8. Once the backwash cycle is complete, press any button for 3 seconds and advance the valve to the rinse cycle. Allow the system to rinse for the full cycle. The water coming out of the drain should be running clear. If not, repeat this step until the water is clear.

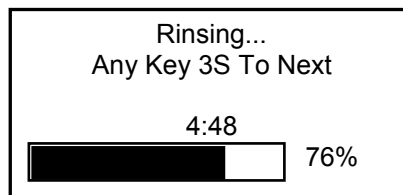

9. After the rinse mode, the valve will go to the refill mode. Allow the valve to complete the refill cycle. Now add 5 gallons of water to the brine tank. When the brine fill is complete, the valve will move to the service mode.

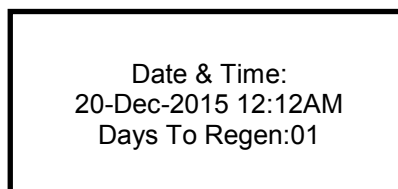

10. Now pour at least two bags of salt in the brine tank. Return to the “Salt Mode” and change it to the proper setting for the feed water parameters. **The installation is now complete!**



## Maintenance

Maintenance of the water softener requires very little time or effort but it is essential. Regular maintenance will ensure many years of efficient and trouble-free operation.

1. Periodically make sure the supply pump is performing satisfactorily to ensure sufficient water is available for regeneration.
2. Periodically test the raw and softened water to ensure conditions are still the same for the original settings and that the unit is working the way it is intended to.
3. Periodically check that the drain line is clear and free from any obstructions.
4. A resin cleaner may be used if the unit is used to remove iron or high hardness levels.

### **System Care**

To retain the attractive appearance of the new water system, clean occasionally with mild soap solution. Do not use abrasive cleaners, ammonia or solvents. Never subject the system to freezing or to temperatures above 100°F.

**Parts list of Standard connection assembly :**

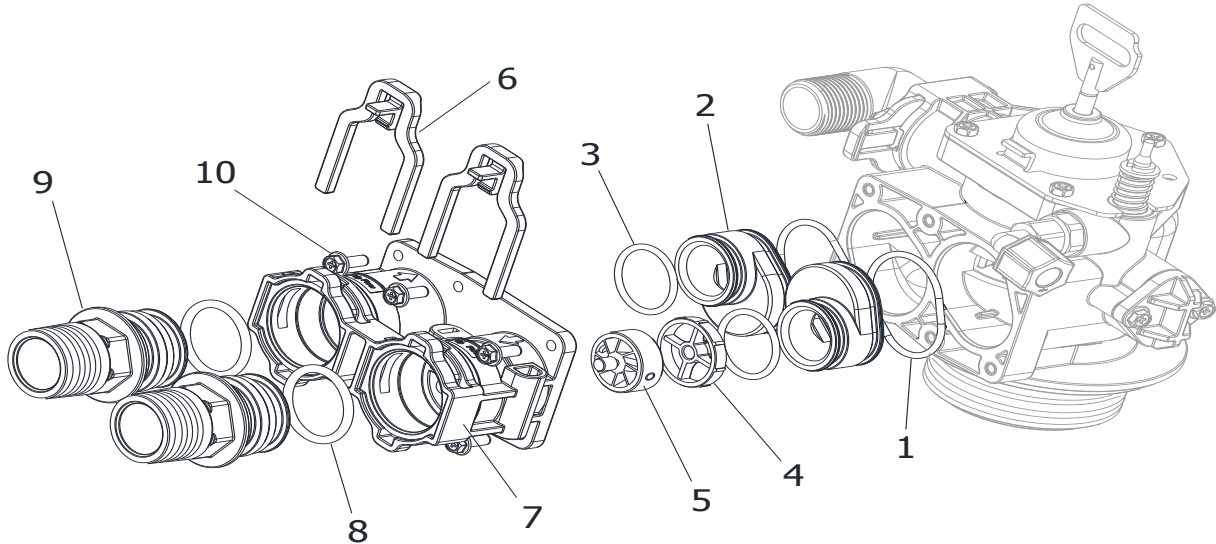

No.	Part description	Qty	No.	Part description	Qty
1	<u>Big O-ring of Adaptor coupling</u>	2	6	89 secure clip	2
2	Adaptor coupling of 89 control valve	2	7	89 valve connector	1
3	Small O-ring of adaptor coupling	2	8	Connector O-ring	2



**Parts list of control valve body :**

No.	Part description	Qty
1	89 valve body	1
2	95 secure clip	1
3	DLFC assembly : optional 1S、2S、3S、4S、 1#、3#、4#、5#、6#	1
4	Drain elbow O-ring	1
5	Drain elbow : 1/2"、3/4"	1
6	Brine valve injector stem assembly	1
7	Spacer and seal assembly	1
8	Three options of piston Down flow piston Up flow piston Filter piston	1

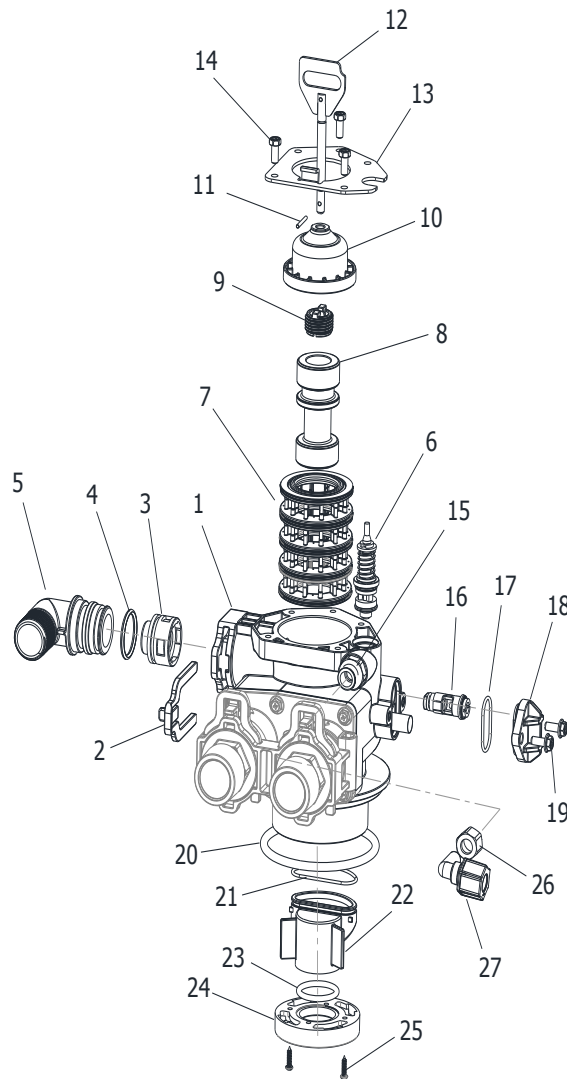

8	Three options of piston Down flow piston Up flow piston Filter piston	1
9	Piston retainer	1
10	End plug	1
11	Piston pin	1
12	Piston rod	1
13	<u>End plug retainer</u>	1
14	End plug retainer screws	3
15	Brine line adaptor assembly : optional BLFC : 0.7gpm BLFC : 0.95gpm	1
16	Injector assembly : optional grey, purple, red, white, blue, yellow	1
17	Injector cover O-ring	1
18	Injector cover	1
19	Injector cover screws	2
20	Tank mouth O-ring	1
21	Adapter O-ring	1
22	Center pipe adapter	1
23	Center pipe O-ring	1
24	Valve <u>bottom connector</u>	1
25	Bottom connector screws	2
26	Brass nuts	1
27	Brine line elbow assembly	1

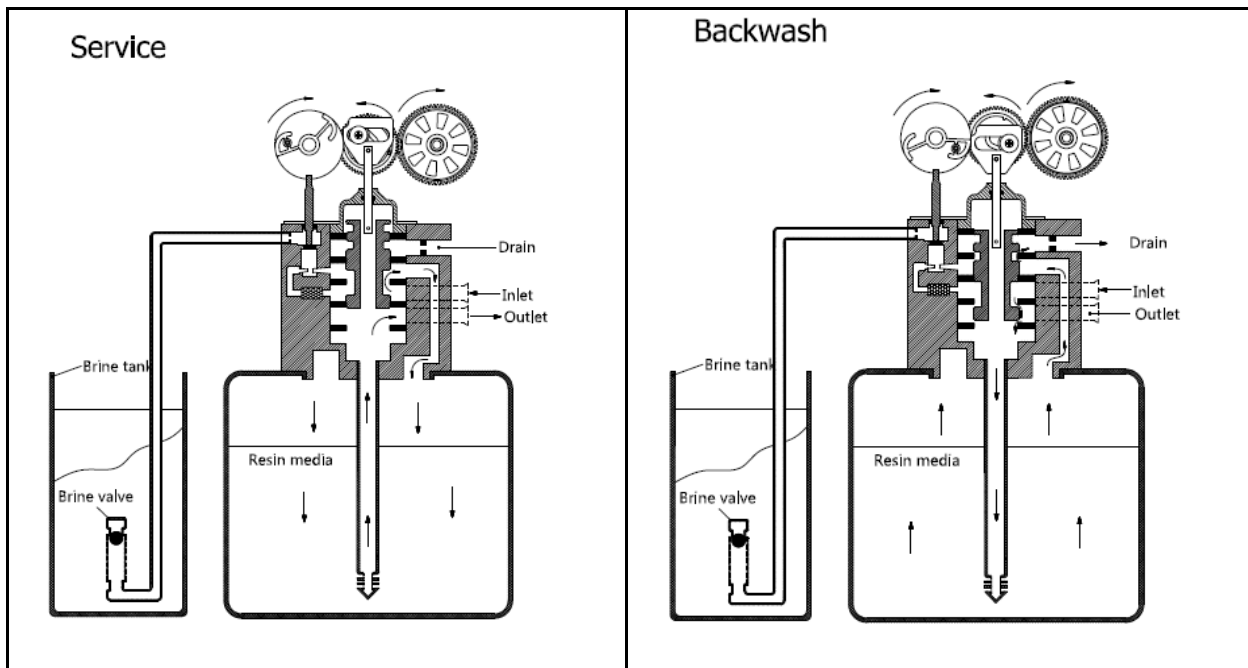

8	Three options of piston Down flow piston Up flow piston Filter piston	1
9	Piston retainer	1
10	End plug	1
11	Piston pin	1
12	Piston rod	1
13	End plug retainer	1
14	End plug retainer screws	3
15	Brine line adaptor assembly : optional BLFC : 0.7gpm BLFC : 0.95gpm	1
16	Injector assembly : optional grey, purple, red, white, blue, yellow	1
17	Injector cover O-ring	1
18	Injector cover	1
19	Injector cover screws	2
20	Tank mouth O-ring	1
21	Adapter O-ring	1
22	Center pipe adapter	1
23	Center pipe O-ring	1
24	Valve bottom connector	1
25	Bottom connector screws	2
26	Brass nuts	1
27	Brine line elbow assembly	1

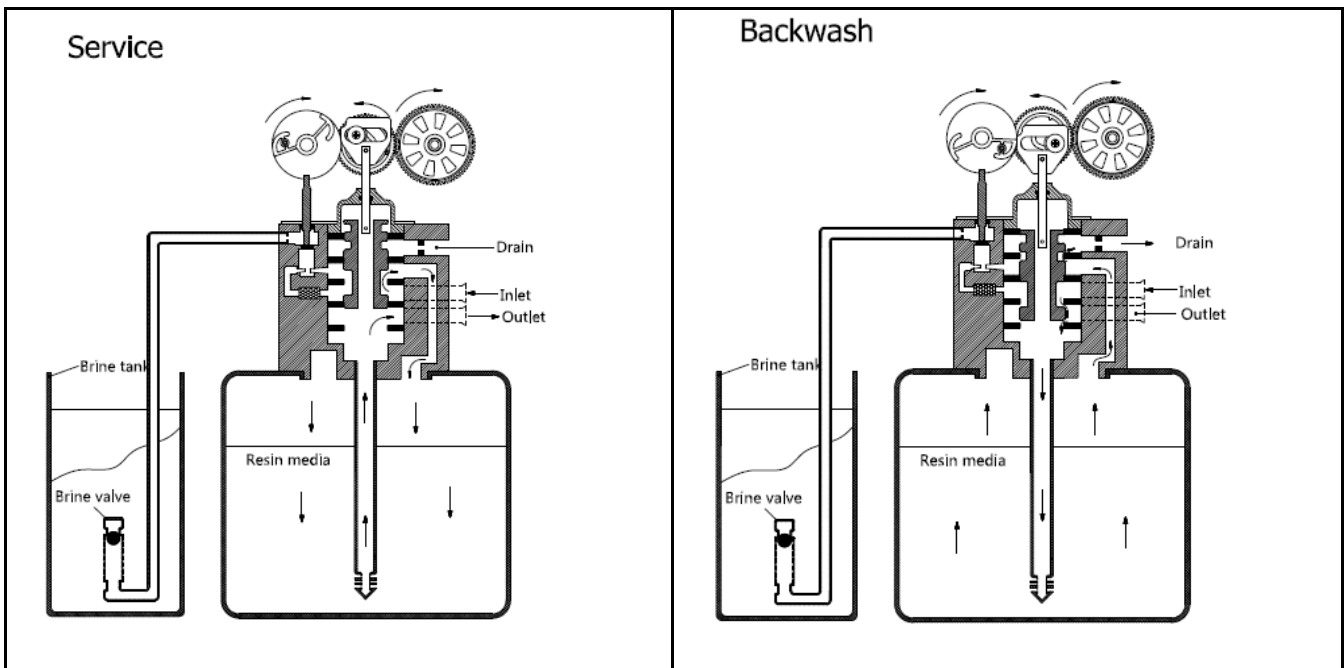



## Limited Lifetime Warranty

For the lifetime of the original purchaser, at the original residential place of installation of this *Fusion NLT* Water Softening System, *US WATER SYSTEMS, INC.* warrants the following:

### LIFETIME COVERAGE

#### Resin Tank, Brine Tank, Resin

Free of all costs to you except transportation and labor charges, we warrant that we will replace or repair the fiberglass media tank, brine tank and/or resin if for any reason it is found to be defective, because of faulty materials or workmanship.

### TEN YEAR COVERAGE

#### Head Assembly & Electronics

We warrant that for ten (10) years from the date of purchase, we will repair or replace the head assemblies or electronic components at no charge to you except for transportation and standard labor charges. Electronics damaged due to environmental issues or improper installation are not covered. 100% full replacement if warranted for the first seven (7) years and three (3) years pro-rated on the eighth, ninth and tenth year.



### GENERAL PROVISIONS

This warranty does not apply to any commercial or industrial installations or to any part of the water conditioner which has been subjected to misuse, neglect, alteration or accident; or to any damage caused by fire, flood, freezing, Acts of God, or any other casualty, or if the original serial numbers have been removed.

These warranties are in lieu of all other warranties expressed, or implied, and we do not authorize any person to assume for us any other obligation on the sale of this water conditioner. No responsibility is assumed for delays or failure to meet these warranties caused by strike, government regulations or other circumstances beyond the control of *US WATER SYSTEMS, INC.*

TO OBTAIN WARRANTY SERVICE, CALL OR WRITE: *US WATER SYSTEMS, INC. 1209 COUNTRY CLUB ROAD INDIANAPOLIS, IN 46234 (800) 608-USWA.*

ANY IMPLIED WARRANTIES OF FITNESS OR MERCHANTABILITY ARE LIMITED TO THE TERMS OF THIS EXPRESSED WARRANTY AND THERE ARE NO WARRANTIES WHICH EXTEND BEYOND THOSE HEREIN. *US WATER* SHALL NOT BE LIABLE FOR ANY INCIDENTAL OR CONSEQUENTIAL DAMAGES.

SOME STATES DO NOT ALLOW THE EXCLUSION OR LIMITATIONS OF INCIDENTAL OR CONSEQUENTIAL DAMAGES SO THE ABOVE LIMITATION MAY NOT APPLY TO YOU. THIS WARRANTY GIVES YOU SPECIFIC LEGAL RIGHTS, AND YOU MAY ALSO HAVE OTHER RIGHTS WHICH VARY FROM STATE TO STATE.

THIS WARRANTY MAY BE TRANSFERRED TO A SUBSEQUENT OWNER WITH WRITTEN APPROVAL OF *US WATER* AND PAYMENT OF STANDARD TRANSFER FEE.

**US Water**  
systems.com