

Visit us online at
www.uswatersystems.com

US Water
systems.com

US Water Systems Commercial/Residential inFusion Super-Filter



**inFUSION**
Superfilter

Owners Manual

Models:

089-IF-150, 089-IF-250, 089-IF-400, 089-IF-500

REVISION # 1.1
REVISION DATE June 27 2017

US Water Systems Corporate Office
1209 Country Club Road
Indianapolis, IN 46234
info@uswatersystems.com
www.uswatersystems.com
1-800-608-8792



Table of Contents

	PAGE
Unpacking / Inspection	2
Safety Guide	2
Proper Installation	3
Specification	4
Before Starting Installation	5
Sizing Requirements	7
Installation Instructions	8
System Start Up	10
About The System	12
Maintenance	14
Main Repair Parts	16
Trouble Shooting	23
Warranty	24

Unpacking / Inspection

Be sure to check the entire unit for any shipping damage or missing parts. Also note damage to the shipping cartons. Contact US Water Systems at 1-800-608-8792 for all damage and loss claims. **A damage claim must be made within 24 hours of receipt of the unit or the claim may not be honored.**

Small parts, needed to install the filter, are in a parts bag. To avoid loss of the small parts, keep them in the parts bag until they are ready to be used.

Safety Guide

For general safety, the information in this manual must be followed to minimize the risk of electric shock, property damage or personal injury.

- Check and comply with the provincial / state and local codes. These guidelines must be followed.
- Use care when handling the filter tank. Do not turn upside down, drop, drag or set on sharp protrusions.
- The system works on 12 volt-60 Hz electrical power only. Be sure to use only the included transformer.
- Transformer must be plugged into an indoor 120 volt, grounded outlet only.
- **WARNING:** This system is not intended for treating water that is microbiologically unsafe or of unknown quality without adequate disinfection before or after the system.



Features and Benefits

The new inFusion Commercial SuperFilter is a revolutionary filtration system engineered using 21st Century Technology for the reduction or removal of iron, manganese and sulfur... not only that, but it also can remove arsenic and other heavy metals. It is sustainable, reliable and economical. Additionally, no chemicals are required and it wastes up to 75% less water than other such filters. This is a heavy-duty commercial-grade system for the worst iron, sulfur and/or manganese.

Features and Benefits

- **Chemical –Free** – Does not require chlorine or potassium permanganate. In about 15% of the applications it can require the use of a very small amount of Hydrogen Peroxide (H₂O₂) which is composed of the elements of water, to increase the Oxidation Reduction Potential (ORP) of the water, however, no Hydrogen Peroxide residual remains.
- **Unsurpassed Performance** -The US Water inFusion Superfilter outperforms conventional multimedia due to its unique zeolite structure.
- **Green by Design** - The US Water inFusion Superfilter uses up to 80% less waste water compared to any conventional media like BIRM, Greensand, Greensand Plus, Filox, Pyrolox and many other old technologies, because it weighs half as much.
- **Superior Performance** - The US Water inFusion Superfilter media is a high performance media which is coated with a heavy, non-destructible layer of manganese dioxide which is a perfect weight for backwashing – lasts 5 to 10 years.
- **Better Filtration** - One of the advantages of the US Water inFusion Superfilter is its superior filtration rating which translates to enhanced water quality.

inFusion Superfilter Contaminant Removal

- Iron - Up to 50 ppm*
- Manganese - Up to 3 ppm*
- Sulfur – Up to 20 ppm*
- Arsenic – Up to 120 ppb*
- Sediment - Down to below 5 Microns
- pH – 6.0 to 9.0*
- Other Contaminants – Reduces Uranium, Radium, Arsenic, Copper and Lead*

The US Water inFusion Superfilter uses all NSF and FDA approved components, including the inFusion Filter Media which is Tested and Certified by the WQA to NSF/ANSI 61 and contains no silica because it is banned by the State of California.



How the inFusion Superfilter Works

The inFusion Commercial Superfilter utilizes a revolutionary space-age media along with ORP Boosting (when necessary) and Oxidation to reduce or remove iron (both ferrous, ferric and bacterial), sulfur (including sulfur reducing bacteria) and manganese. It also reduces or removes arsenic and heavy metals when sufficient iron is present to bind the arsenic to the iron. The new inFusion Advanced Oxidation media is a special Zeolite media with a robust coating of manganese dioxide, manufactured with techniques impossible until recently.

inFusion Advanced Oxidation media has an angular shape with a rough high micro-porous structure which provides a huge surface area for efficient oxidation of iron, sulfur and manganese and creates very little pressure loss and high service flow rates combined with lower backwash frequency.

Other medias (such as Birm and Greensand Plus) have very little manganese dioxide which is the simple explanation as to why the inFusion Advanced Oxidation media works 100 TIMES BETTER! On the other hand, medias like Filox and Pyrolox are twice as heavy and require massive volumes of water to properly backwash the media. In many cases the backwash flow rate is DOUBLE that of inFusion Advanced Oxidation media.

The inFusion Commercial electronic computer control cleans the media of accumulated contaminants, then delivers clean, clear, fresh water throughout the home. The electronic control is easy to set and once set, it never has to be set it again, because it has a built-in capacitor which keeps the memory up to 72 hours in case of power failure. A 5 Micron pre-filter is installed prior to the inFusion Superfilter to ensure that it is being exclusively utilized for removal of iron, sulfur, manganese and other target contaminants. The computer control can be set to regenerate on pressure drop (more about that later).

Iron, sulfur and manganese are oxidized on the inFusion Advanced Oxidation media, while other heavy metals, like arsenic, are bound to the iron and backwashed out. The inFusion Superfilter backwash frequency is determined with the pressure gauges that are supplied before and after the unit. A pressure differential reading (the difference in pressure readings on the inlet and outlet gauges) determines the backwash frequency (days between backwashes).

When the unit is initially put in service, the inlet and outlet pressure should be recorded. This is the service pressure drop. Once a 6-10 PSI differential in addition to the initial service pressure drop is observed, the filter should be backwashed. The number of days the filter operates in service without exceeding the pressure differential should be recorded. The unit can then be programmed according to days recorded between backwashes.



Operating the inFusion Superfilter

The US Water inFusion Superfilter is one of the most amazing and revolutionary filtration products ever conceived! Not only does it effectively remove iron, sulfur and manganese, but it is extremely versatile for many other varying water conditions and contaminants.

If the inFusion Superfilter is being considered, the ORP level of the feed water needs to be tested. This is a test that must be done onsite and is accomplished using a handheld ORP meter. Once the ORP has been tested, if the ORP is over -170 mV, the ORP Booster System is not required. However if the ORP is below -170 mV and/or there is iron or sulfur reducing bacteria, the ORP Booster System must be utilized. Periodic testing the water is recommended at least once a month to confirm that the ORP is above -170 mV.

The US Water inFusion Superfilter works effectively when the pH is between 6.0 - 9.0 for iron, sulfur and manganese removal. When removing arsenic, it is best that the pH is 7.0 or slightly lower.

An inFusion system should be sized to continuous flow – peak flow should be something that does not happen regularly. Iron, sulfur and manganese are the result of prolonged contact, so the lower the flow rate, the better the contaminant(s) is removed.

Remember, the well and pump, must be capable of delivering the appropriate backwash flow for the system size that is applied. The system can be installed as a single unit or a dual, triple or even a quad system, in parallel. For example, if a 20 GPM flow rate is needed, but the well pump could only produce 12 GPM, it may be better to have two 10 GPM systems plumbed in parallel (a 10 GPM system only requires 10 GPM to backwash).



Specifications

Specifications	inFusion Superfilter			
	089-IF-150	089-IF-250	089-IF-400	089-IF-500
Service Flow Rates				
Normal	3.8 GPM	6.4 GPM	10.4 GPM	15 GPM
Peak	5.4 GPM	9.1 GPM	14.9 GPM	21.5 GPM
Micron Rating	3 Micron	3 Micron	3 Micron	3 Micron
Backwash Flow Rate (Button #)	6 GPM (5S)	9.5 GPM (2)	14 GPM (3)	21 GPM (5)
Filter Media Volume - Cubic Feet	1.5 FT3	2.5 FT3	3.0 FT3	4.0 FT3
Filter Tank Size	10" X 54"	13" X 54"	16" X 65"	18" X 65"
Plumbing Connections	1" Male NPT			
Electrical Requirements	Input 120V 60 Hz - Output 12V 650mA			
Water Temperature	Min. 39 - max. 100 degrees Fahrenheit			
Water Pressure	Min. 20 - Max 125 psi			

- Continuous operation at flow rates greater than the service flow rate may affect capacity and efficiency performance.
- The manufacturer reserves the right to make product improvements which may deviate from the specifications and descriptions stated herein, without obligation to change previously manufactured products or to note the change.
- Peak flow rates are intended for intermittent use only and are for residential application only
- At the stated service flow rates, the service pressure drop through these devices should not exceed 15 psig

Before Starting Installation

Tools, Pipe, and Fittings, Other Materials

- Pliers
- Screwdriver
- Teflon tape
- Razor knife
- Two adjustable wrenches
- Additional tools may be required if modification to home plumbing is required.
- Plastic inlet and outlet fittings are included with the filter. To maintain full valve flow, 1" pipes to and from the filter fittings are recommended. The same, or larger, pipe size should be maintained as the water supply pipe, up to the filter inlet.
- Use copper, brass, or PEX pipe and fittings.
- Some codes may also allow PVC plastic pipe.
- ALWAYS install the included bypass valve, or 3 shut-off valves. Bypass valves allow the water to the filter to be shut off for repairs if needed, but still provide water in the house pipes.
- 3/4" drain line is required.



Sizing Requirements

Water Pressure

The water system must have a pump large enough to deliver the recommended backwash rate with a minimum pressure at the inlet of the filter of 30 psi. If the existing system cannot do this, it must be upgraded to do so. Whenever possible, the water system should be adjusted to deliver at least 30 psi for even more satisfactory results.

Backwash Flow Rates

The most important criteria in sizing a filter is the capacity of the pump/supply flow and pressure. The water must pass through the filter media at the proper service flow rate. The filter must also be backwashed at a flow rate sufficient to dislodge and remove the captured particles. Failure to provide sufficient water will cause a build-up of particles in the filter media, impairing its ability. In order for the filter to backwash and rinse properly, the pump/supply flow and pressure must be capable of providing the backwash flow rates indicated on page 6.

Checking Available Flow Rate

There are several ways to check the available flow rate of the water supply. The following method is intended to be simple for any application. A bucket of known volume (5 gallon buckets are typically used) and a stop watch is required.

1. Go to a point of use that will allow full flow when opened. This can be a garden spigot or a fully ported valve or faucet.
2. Open the point of use and allow the water to run in the bucket. If the water source is supplied by a well pump allow the water to run until the pump starts then convey into the bucket.
3. Use the stop watch to monitor how long it takes to fill the 5 gallon bucket. Use the following equation to find the flow rate available;

$$60 \text{ Seconds} / \text{Bucket fill time (seconds)} * \text{Bucket Volume} = \text{Flow rate (GPM)}$$



Where To Install The Filter

- Place the filter tank as close as possible to the pressure tank (well system) or water meter (city water).
- Place the filter tank as close as possible to a floor drain, or other acceptable drain point (laundry tub, sump, standpipe, etc.).
- Connect the filter to the main water supply pipe BEFORE the water heater. **DO NOT RUN HOT WATER THROUGH THE FILTER.** Temperature of water passing through the filter must be less than 100 deg. F.
- Do not install the filter in a place where it could freeze. **Damage caused by freezing is not covered by the warranty.**
- Put the filter in a place water damage is least likely to occur if a leak develops. **The manufacturer will not repair or pay for water damage.**
- A 120 volt electric outlet, to plug the included transformer into, is needed within 6 feet of the filter. The transformer has an attached 6 foot power cable. **Be sure the electric outlet and transformer are in an inside location, to protect from wet weather.**
- If installing in an outside location, the necessary steps must be taken to assure the filter, installation plumbing, wiring, etc., are as well protected from the elements, contamination, vandalism, etc., as when installed indoors.
- **Keep the filter out of direct sunlight.** The sun's heat may soften and distort plastic parts.

Proper Installation

This water filter system must be properly installed and located in accordance with the Installation Instructions before it is used.

- **Do not** install or store the filter where it will be exposed to temperatures below freezing or exposed to any type of weather. Water freezing in the system will break it. Do not attempt to treat water over 100° F.
- **Do not** install in direct sunlight. Excessive sun or heat may cause distortion or other damage to non-metallic parts.
- Properly ground to conform with all governing codes and ordinances.
- Use only *lead-free solder and flux* for all sweat-solder connections, as required by state and federal codes.
- Maximum allowable inlet water pressure is 125 psi. If daytime pressure is over 80 psi, night time pressure may exceed the maximum. Use a pressure reducing valve to reduce the pressure if necessary.
- **WARNING:** Discard all unused parts and packaging material after installation. Small parts remaining after the installation could be a choke hazard.

3-Valve Bypass Layout Drawing with Pressure Gauges

IMPORTANT—PLEASE REFER TO THE PICTURE BELOW ON INLET/OUTLET SIDE OF THE VALVE

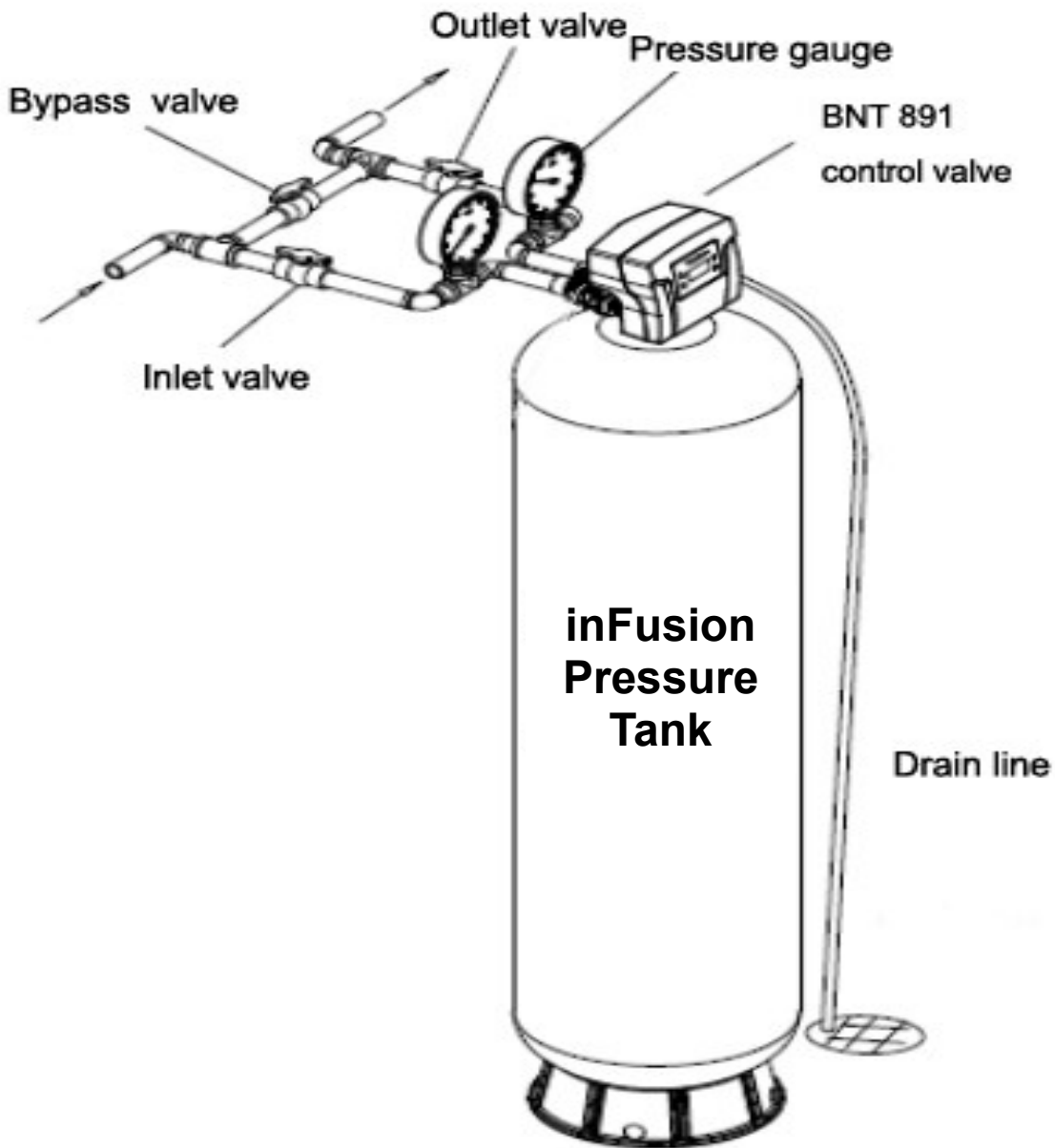

Typical Backwashing Filter

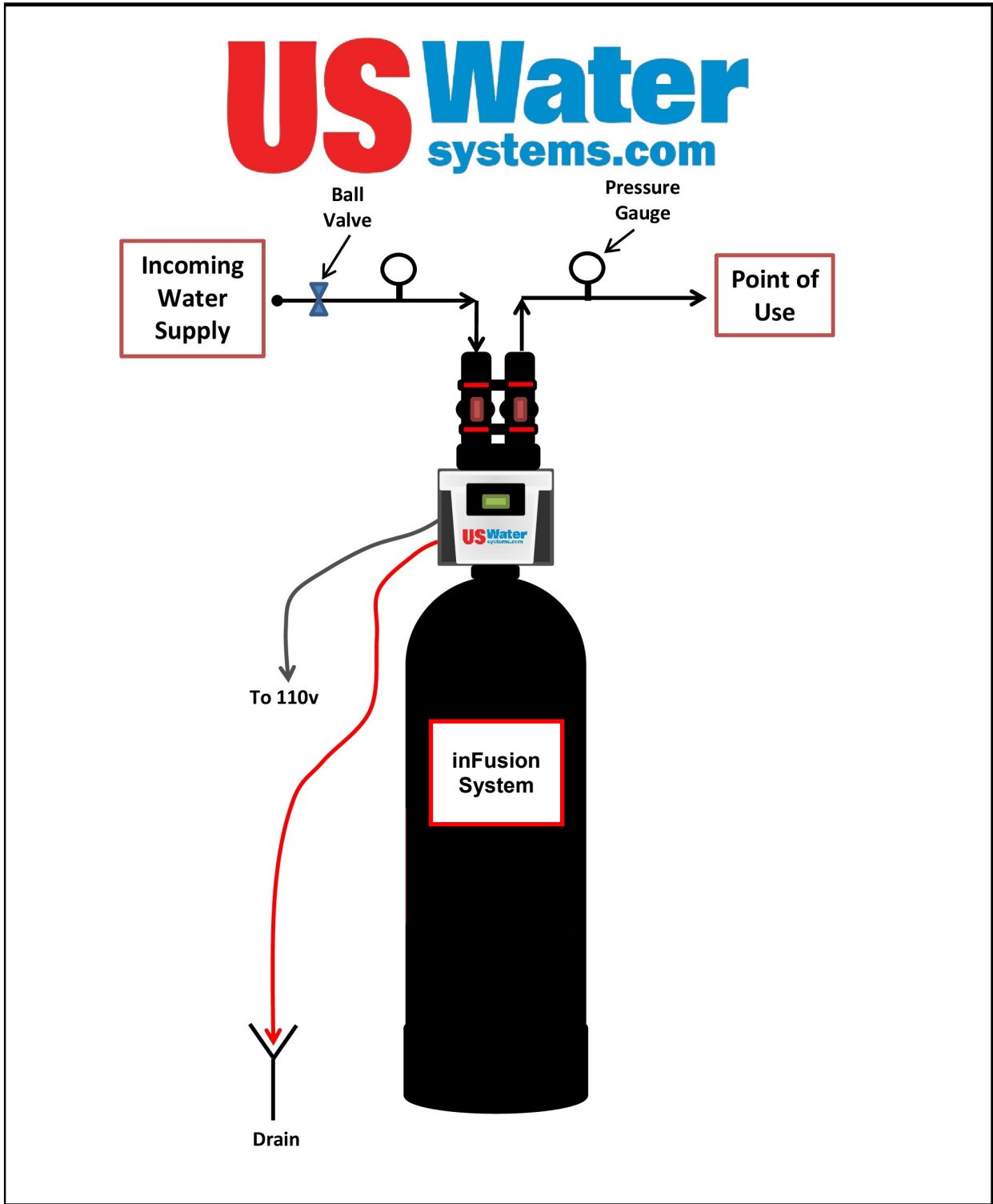

Fusion Backwashing Filter Tank Preparation

WATER PRESSURE: A minimum of 30 pounds of water pressure is required for regeneration valve to operate effectively.

ELECTRICAL FACILITIES: An uninterrupted alternating current (A/C) supply is required. Note: Other voltages are available. Please make sure the voltage supply is compatible with the unit before installation.

EXISTING PLUMBING: Condition of existing plumbing should be free from lime and iron buildup. Piping that is built up heavily with lime and/or iron should be replaced.

LOCATION OF INFUSION TANK AND DRAIN: The Infusion tank should be located close to a drain to prevent air breaks and back flow.

BY-PASS VALVES: Always provide for the installation of a by-pass valve if unit is not equipped with one.

CAUTION: Water pressure is not to exceed 80 psi, water temperature is not to exceed 110°F (43°C), and the unit cannot be subjected to freezing conditions.

1. Remove the tank from carton.
2. Verify the distributor tube is centered in the bottom of the tank. A flashlight may be necessary. There is a small indentation in the bottom of the tank that will allow the distributor tube to drop in place. The top of the distributor tube will be flush with the top of the tank when it is installed correctly.

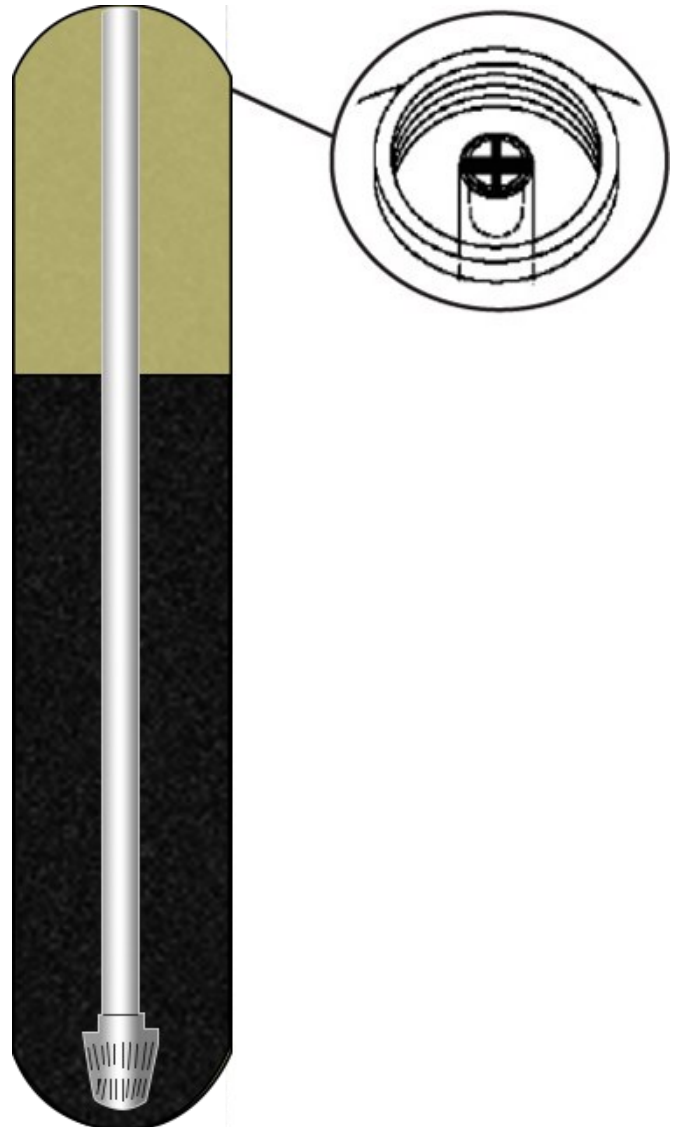

3. Place a piece of duct tape over the distributor tube so no gravel or media enters the opening while filling.



4. Use the Blue Funnel provided, to pour the **GRAVEL in FIRST** and the **MEDIA in SECOND**. Pour gravel and media evenly around the hole to ensure it is well distributed in the tank. Pour it slow enough, to prevent the funnel from plugging. A helper may be needed to hold the funnel during the filling process. It is recommended that a dust mask and safety goggles be worn to prevent possible injury. A shop vacuum can be held in the area to help control the dust created by the filling process. Pour all the gravel and media that was shipped in the tank. US Water Systems **DOES NOT** ship extra gravel or media.



5. When the gravel and media are installed move tank side to side to settle the media. Remove the funnel and tape from the distributor tube. It is a good practice to fill the tank with water and allow the media to saturate.

6. Lubricate the distributor O-ring and the tank O-ring on the bottom of the control valve. Then install the upper basket on the bottom of the valve by lining up the tabs then turning the basket clockwise to lock it in place. Place the upper basket over the distributor tube and push the valve on the tank. Thread the valve on the tank by turning it clockwise. **Be sure** not to cross-thread the valve on the tank. Tighten the valve hand tight, then snug it further by tapping it with the palm of the hand on the pipe connection side of the valve. **DO NOT** use tools to tighten the valve or damage could occur.

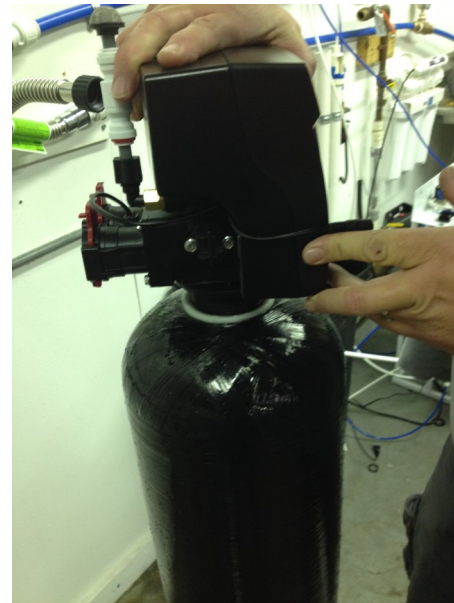

7. Lubricate the O-rings on the bypass valve and 1" threaded connectors. Remove the red clips and install the bypass on the control valve. Re-install the red clips once the bypass is in place. Put the bypass valves in the bypass position (picture shows "Service Position", see page 18 for valve position)

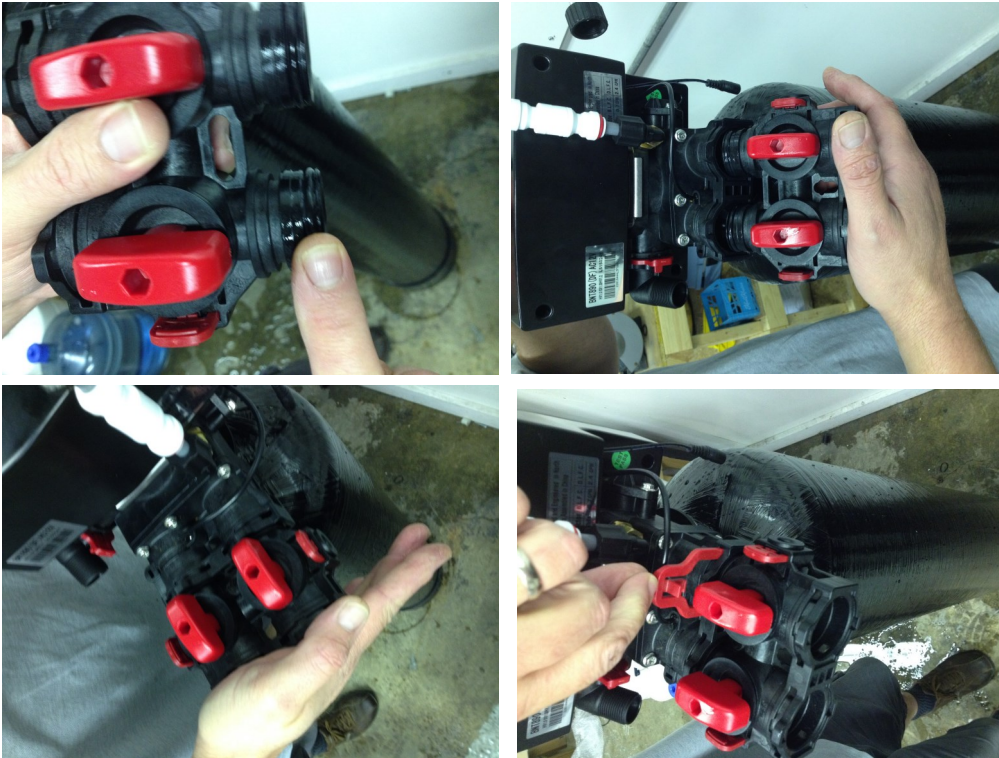

8. Apply Teflon tape to the 1" connectors. Remove the red clips from the previously installed bypass and install the 1" connectors in the bypass valve. Re-install the red clips for the 1" connectors.



Note: As the picture shows, connect the inlet and outlet according to the arrow direction which can be seen from the top view of the control valve.

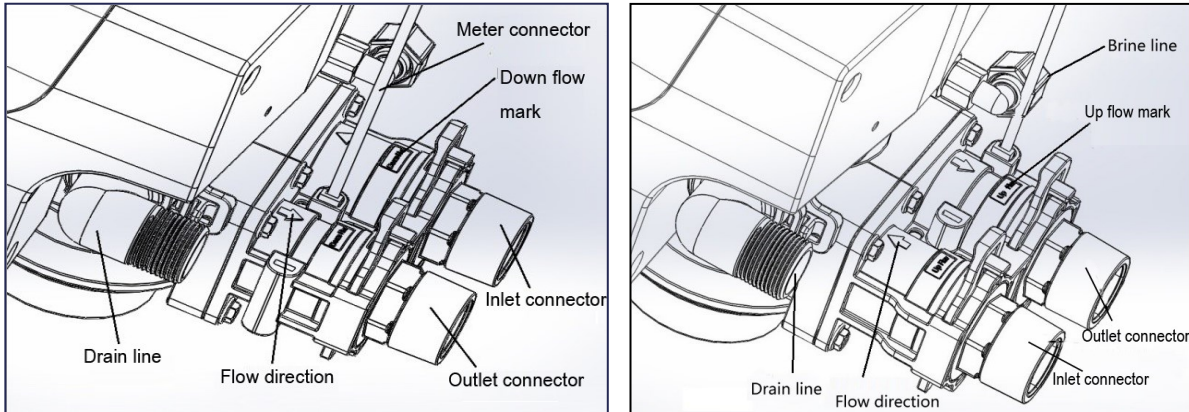

The installation of 1" integrated bypass valve:

If the 1" integrated bypass is used instead of a three manual valve, the installation method is shown in the picture below.

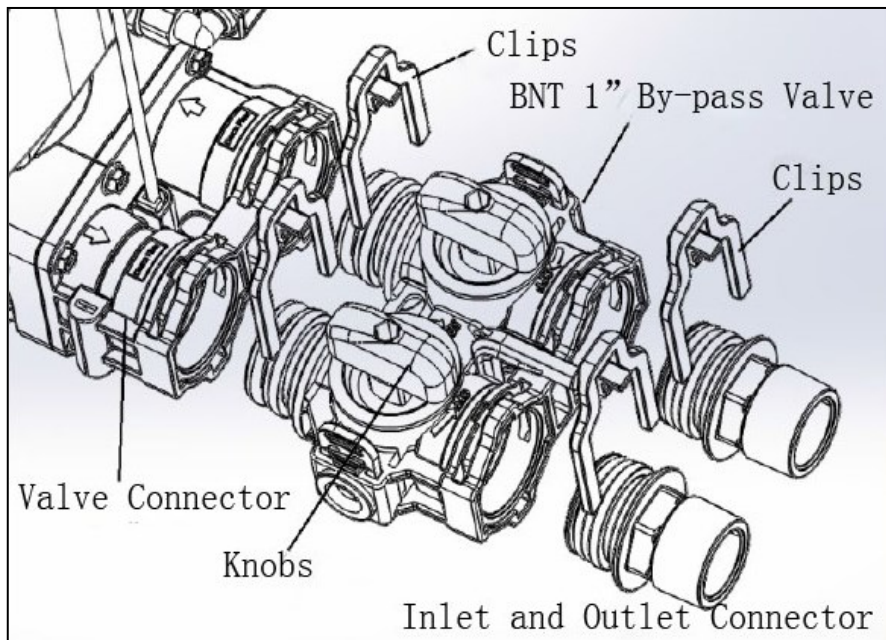

9. Install the inFusion system close to the water source. **BE SURE** to install the inFusion system directly after the well pressure tank. It is a good practice to add a sediment filter prior to the inFusion system between the pressure tank and the inFusion tank. Shut off the main water supply and relieve the pressure on the plumbing system.
10. Install the inlet plumbing on the inlet side of the control valve and the outlet plumbing on the outlet of the control valve. The inlet and outlet can be identified by the arrows on the control valve. The arrow pointing toward the control valve is the inlet. The arrow pointing away from the control valve is the outlet. (Optional flexible connectors shown utilize rubber washer seals and do not require Teflon tape).
11. Install a gauge in the inlet and outlet plumbing. Use the tee fitting that matches the piping material. The tee must have a 1/4" female threaded port to accept the gauge. (The picture below shows optional brass fittings utilizing Shark-bite® fittings to convert to PEX piping).

Note: The gauges are included but the fittings are not.

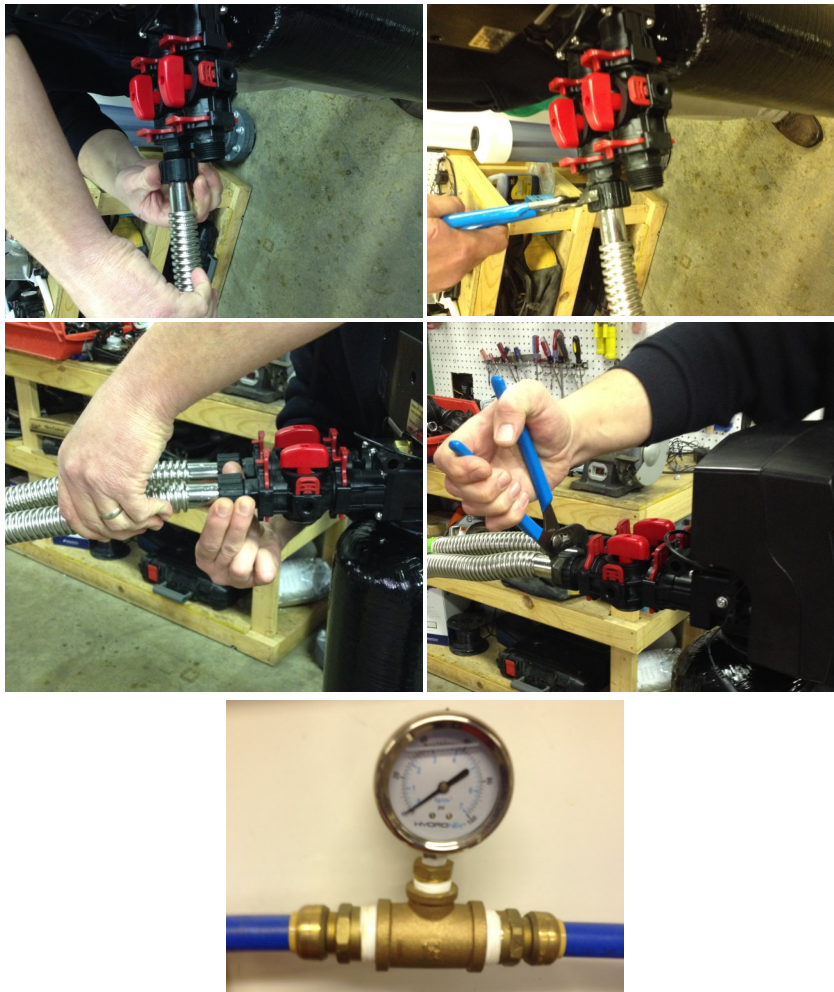

NOTE: The Fusion system is equipped with a bypass valve. If a 3 valve bypass in the plumbing system is in place or preferred, the supplied bypass is not required.

13. Install the drain line on the 3/4" threaded elbow. This should be a 3/4" solid pipe conveyed to a floor drain, sink drain or stand pipe. This drain line can be any material allowed by the local code (photos show PEX but PVC is typically the piping used). An air gap should be established if the local code requires it. Drain line smaller than 3/4" could cause a restriction on the system and prevent it from backwashing properly. If the drain line is reduced to a size smaller than 3/4" **BE SURE** it can provide the backwash flow rate requirement of the unit being installed. Drain line larger than 3/4" is acceptable. The system will drain with pressure, so the drain line can be ran vertically for up to 5'. If the drain line is ran vertically then along the wall horizontally, make sure the horizontal pipe/tubing has a drop to the final drain point. The system should be plumbed with the least amount of back pressure on the drain line.



14. The drain elbow can be removed by removing the red clip and pulling the elbow out of the valve. This will make it easier to connect the plumbing fitting used. **BE CAREFUL** not to cross thread the fitting on the elbow. **There is a small thread tolerance for this fitting to help reduce the potential for a leak so it can be cross threaded easily.**

NOTE: It may be necessary to install drain line larger than 3/4" on a linear stretch of drain line that exceeds 15'.

1. When the two knobs on the bypass valve are parallel, the inlet and outlet are open, this state of operation is “Service”;
2. Rotate each of the two knobs in clockwise and counterclockwise respectively, when the knobs on the bypass is in one line, the inlet and outlet are both closed, this state of operation is “By-pass”.

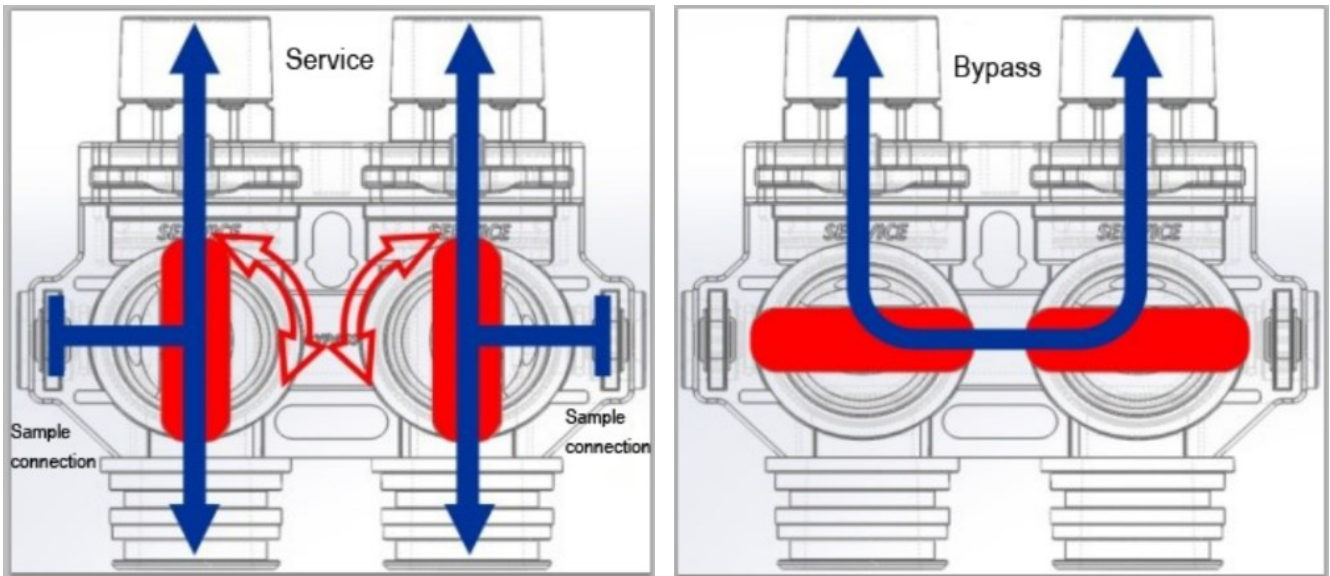



Button Configuration

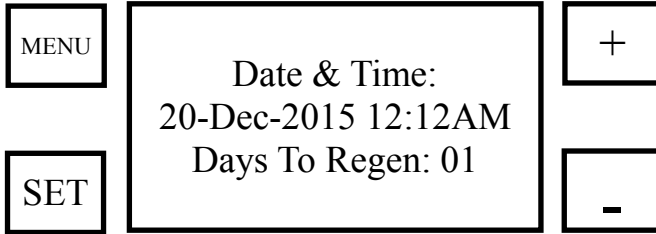

Key Pad Configuration

MENU	This function is to enter the basic set up information required at the time of installation.
SET	This function is to accept the values if changed and advance to the next page in the menu.
+ / -	These buttons are used to increase or decrease the value of the settings while in the programming mode.

Programming Levels

There are 3 levels to the valve program. Master options and Factory options are typically adjusted at the factory. These options link the PCB function with the type of control valve and should not be tampered with. Advanced options are used to configure the unit when the valve is assembled to the tank so that it can function as the proper size and intended system operation. Settings are the final options chosen when the unit is installed to a specific location.

PROGRAM LEVEL	USER ACCESS
USER SETTINGS(I)	These settings are programmed when the unit is installed. The settings should only be adjusted by a qualified person.
MAIN MENU (II)	These settings are programmed when the unit is installed. The settings should only be adjusted by a qualified person.
ADVANCED MENU (II)	These settings are programmed by the factory and should be adjusted when the valve is assembled into a unit or system. It contains important settings so the valve will operate properly for the type of system it is intended for. The settings should only be changed by qualified person.
HISTORY MENU (IV)	This menu contains key diagnostics for trouble shooting the system.
FACTORY MENU (V)	These settings are programmed by the factory. The settings are important for the operation of the valve that should only be changed by a qualified person.

The main display page shows the Date, Time Of Day and Days To Regen. The display will alternate between the main page and the dealer information page.

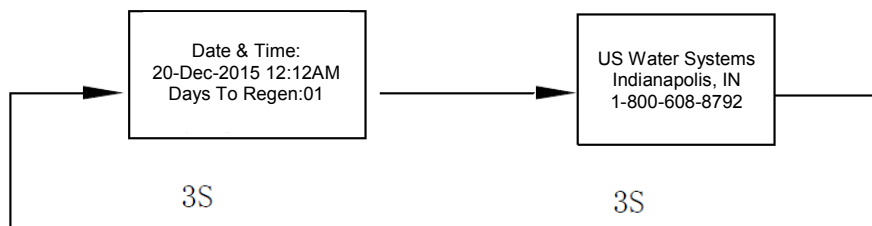



Programming

Press MENU key.
 Press + or - to change menu option. Press SET to enter.
 Press + or - to change value. Press SET to accept.

Advanced Menu

To get to the “Advanced Menu”, press the Menu button to get to the “User Menu”.

- Date & Time Setting
 - Manual Regen.
 - Dealer Information
 - Main Menu

Use the Down arrow to go to “Main Menu” then press and hold the Set button for 5 seconds. This will take the valve to the “Main Menu”.

- =====Main Menu=====

 - Regen. Time Setting
 - Regen. Days Setting
 - Advanced Menu

Use the Down arrow to go to the “Advanced Menu”. Press the Set button to go to the “Advanced Menu”.

- ====Advanced Menu=====

 - Regen. Mode
 - Regen. Cycles
 - History Values

Move the cursor to “Regen Mode” and press the “Set” button

- =====Regen Mode=====

 - Days
 - Calendar
 - Meter Immediate
 - Meter Delayed
 - Meter Override

Use the “UP and DOWN” arrows to move the cursor over the word “Days” and press the “Set” button.

Setting complete
 Press the [] To Return

Press the “Menu” button to save the setting.

- ====Advanced Menu=====

 - Regen. Mode
 - Regen. Cycles
 - History Values

Move the cursor to “Regen Cycles” and press the “Set” button



- =====Regen. Cycles=====

 - Backwash Duration
 - Rinse Duration

Use the “UP or DOWN” arrows to move the cursor over “Backwash Duration” and press the “Set” button.





Programming

=Backwash Duration====
 15 Minutes
 Press [] To Cancel,
 Press [] To Confirm!

Use the UP or DOWN" arrows to change the duration to "15" minutes. Press the "Set" button to save the value.

====Regen. Cycles====
 • Backwash Duration
 • Rinse Duration

Use the "UP or DOWN" arrows to move the cursor over "Rinse Duration" and press the "Set" button.

=Rinse Duration====
 5 Minutes
 Press [] To Cancel,
 Press [] To Confirm!

Use the UP or DOWN" arrows to change the duration to "5" minutes. Press the "Settings" button to save and then press the "Set" button to confirm.

Press the "Menu" button again to go back to the "Advanced Menu". Then press the "Menu" button again to go back to the "Main Menu".



Programming

Main Menu

```
====Main Menu=====
• Regen. Time Setting
• Regen. Days Setting
• Advanced Menu
```

Use the “UP or DOWN” arrows to move the cursor over “Regen. Time Setting” and press the “Set” button.

```
====Regen. Time=====
1:00 AM
Press [ ] To Cancel ,
Press [ ] To Confirm
```

Use the UP or DOWN” arrows to change the duration to 1:00 AM or a least 1 hour after water usage has stopped for the day. Most water softeners are set to regenerate at 2:00 AM so the backwashing filter should be set for 1 hour before the softener is set to regenerate. This will ensure the backwash is complete prior to the potential water softener regeneration. Once the hour value is adjusted, press the “Set” button, then set the minute value, press the “Set” button again, then set the 12 cycle (AM or PM) and press the “Set” button to save the value then press the “Menu” button to confirm the change and return to the “Main Menu”.

```
====Main Menu=====
• Regen. Time Setting
• Regen. Days Setting
• Advanced Menu
```

Use the “UP or DOWN” arrows to move the cursor over “Regen. Days Setting” and press the “Set” button.

```
====Regen. Days=====
20 Days
Press [ ] To Cancel ,
Press [ ] To Confirm
```

Use the “UP or DOWN” to change the “Days” to “20” initially. The inlet and outlet gauges are used to determine that actual setting. When the system is installed the service pressure drop should be recorded. Once the pressure drop increases 6-10 PSI over the service pressure drop the days of use should be recorded. The filter should be regenerated that night and the “Days” setting should then be changed to 1 day less than the recorded days. This will ensure the system backwashes before the pressure drop is observed. Once the days are changed, press the “Set” button to save it and then press the “Menu” button to confirm the setting and return to the “Main Menu”. Press the “Menu” button again to return to the “User Settings”.

Programming

User Settings

- Date & Time Setting
- Manual Regen.
- Dealer Information
- Main Menu

Use the “UP or DOWN” arrows to move the cursor over “Date & Time Setting” and press the “Set” button.

```
====Date and Time====
01 - Jan-2016 06:13 PM
Press [ ] To Cancel,
Press [ ] To Confirm!
```

Use the UP or DOWN” arrows to change the day of the month value then press the “Set” button to save it and move to the month. Once the month is entered, press the “Set” button to save it and move to the year. Once the year is entered, press the “Set” button to save it and move to the hour. Once the hour is entered press the “Set” button to save it and move to the minutes. Once the minutes are entered, press the “Set” button to save it and move to the 12 hour cycle selection. Once AM or PM have been entered, press the “Set” button to save it. Then press the “Menu” button to confirm all the settings.

Programming is now complete!

The following “Manual Regeneration” procedure is for information only. This procedure will be revisited during system startup.

Manual Regeneration

If the screen is locked, press the “Menu” button for 5 seconds to unlock it. Now press the “Menu” button again to get to the “User Setting”.

- Date & Time Setting
- Manual Regen.
- Dealer Information
- Main Menu

Use the “UP or DOWN” arrow to move the cursor to “Manual Regen” and push the “Set” button.

```
Regen. Now?
Regen. Tonight?
Press [ ] To Cancel,
Press [ ] To Confirm!
```

Use the “UP or DOWN” arrow to move the cursor to the desired regeneration type. “Regen. Now” will set the unit into an immediate regeneration. “Regen. Tonight” will set the unit to regenerate at the “Regen. Time” that was selected under the “Main Menu” selection. Once the type of regeneration is selected, press the “Set” button to initiate the regeneration. An immediate (Regen. Now) regeneration will send the valve to the backwash cycle and start the regeneration. A delayed (Regen. Tonight) regeneration is selected, after pushing the “Set” button the “Menu” button must be pressed to confirm the selection. The system will then go back to the home screen and will regenerate at the time selected in the “Main Menu”.

Startup Procedure

1. Be sure the bypass valves are in the “bypass” position (see page 18).
2. Turn on the main water supply and check for leaks in the plumbing.
3. Open a faucet down stream and flush any air from the plumbing. If there are no leaks, move to the next step.
4. Start an immediate manual regeneration (see previous page). The valve may be locked so the “Menu” button may need to be pushed for 5 seconds to unlock the valve.
5. Once the manual regeneration is started the screen will change. Once the valve reaches the backwash position the time on the screen will began to count down.

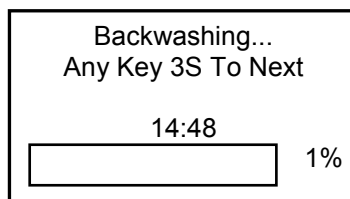

6. When the time is counting down in the backwash position, slowly and slightly open the inlet valve on the bypass open about a 1/4 of a turn. Water will begin to fill the tank.
7. Slowly open the inlet valve in 1/4 turn increments until the valve is completely open and there is a full stream of water coming out of the drain line. If there is a loud “knocking” noise, the valve is being opened to far to fast. Just back the valve off a bit.
8. When the valve is fully open in the backwash position, unplug the control valve and allow the system to backwash for a minimum of 1 hour. If the original startup backwash is shortened, there may be an elevated pH level. **1 hour minimum!**
9. After 1 hour plug the valve back in. The valve will move until it finds the “service” position. The display will look like screen below and the valve motor will stop.

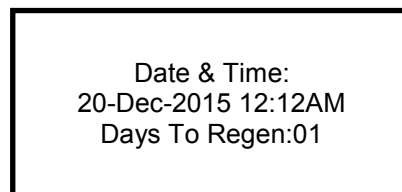

Startup Procedure

10. Now start another immediate regeneration and allow the system to backwash and rinse for the full cycles. The water coming out of the drain should be running clear. If not, repeat this step until the water is clear.

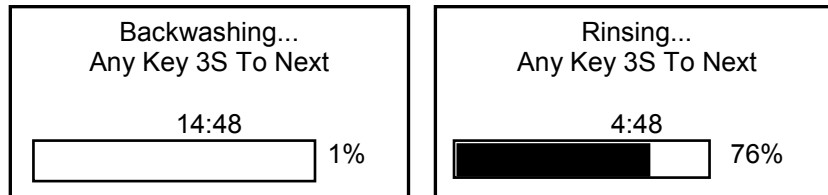

11. Once the valve is back to the "Service" position, open a bath tub faucet or another large usage valve.

Date & Time:
 20-Dec-2015 12:12AM
 Days To Regen:01

12. Record the inlet and outlet pressures on the installed inlet and outlet gauges. The difference in these values will be the "Service Pressure Drop".
13. Record the pressure values of the inlet and outlet gauges daily. Once an additional pressure drop of 6-10 PSI is observed, the filter must be backwashed. The number of days recorded will be the backwash frequency.



14. Now go back to the "Regen. Days" setting in the "Main Menu" and input the number of days between the original startup and when the additional pressure drop was observed. If the system does not show a pressure drop after 14 days, set the "Regen Days" to 14 days. This will ensure the bed is being lifted and redistributed to prevent channeling through the media.
15. Once the final "Regen Days" frequency has been programmed, the system will backwash automatically going forward.
 The installation is now complete!



Maintenance

Maintenance of the water filter requires very little time or effort but it is essential. Regular maintenance will ensure many years of efficient and trouble-free operation.

1. Periodically make sure the supply pump is performing satisfactorily to ensure sufficient water is available for backwashing the filter.
2. Periodically test the raw and filtered water to ensure conditions are still the same for the original settings and that the unit is working the way it is intended to. Water testing is often the best way to determine when the filter media will require replacement.
3. Periodically check that the drain line is clear and free from any obstructions.

System Care

To retain the attractive appearance of the new water filter, clean occasionally with mild soap solution. Do not use abrasive cleaners, ammonia or solvents. Never subject the system to freezing or to temperatures above 100°F.

Parts list of Standard connection assembly :

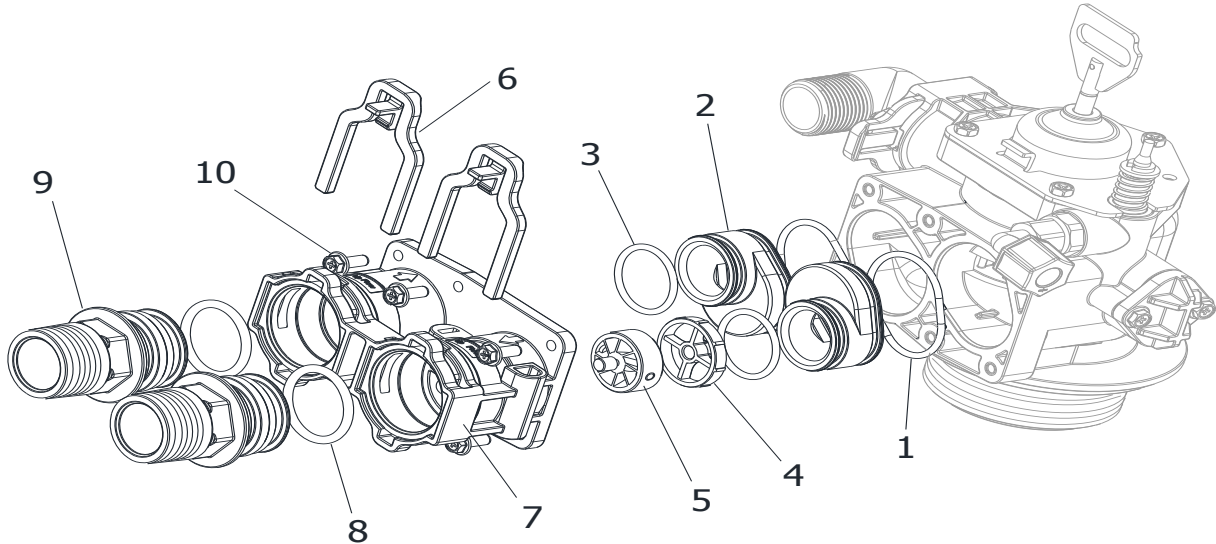

No.	Part description	Qty	No.	Part description	Qty
1	Big O-ring of Adaptor coupling	2	6	89 secure clip	2
2	Adaptor coupling of 89 control valve	2	7	89 valve connector	1
3	Small O-ring of adaptor coupling	2	8	Connector O-ring	2

Parts list of control valve body :

No.	Part description	Qty
1	89 valve body	1
2	95 secure clip	1
3	DLFC assembly : optional 1S、2S、3S、4S、 1#、3#、4#、5#、6#	1
4	Drain elbow O-ring	1
5	Drain elbow : 1/2"、3/4"	1
6	Brine valve injector stem assembly	1
7	Spacer and seal assembly	1
8	Three options of piston Down flow piston Up flow piston Filter piston	1

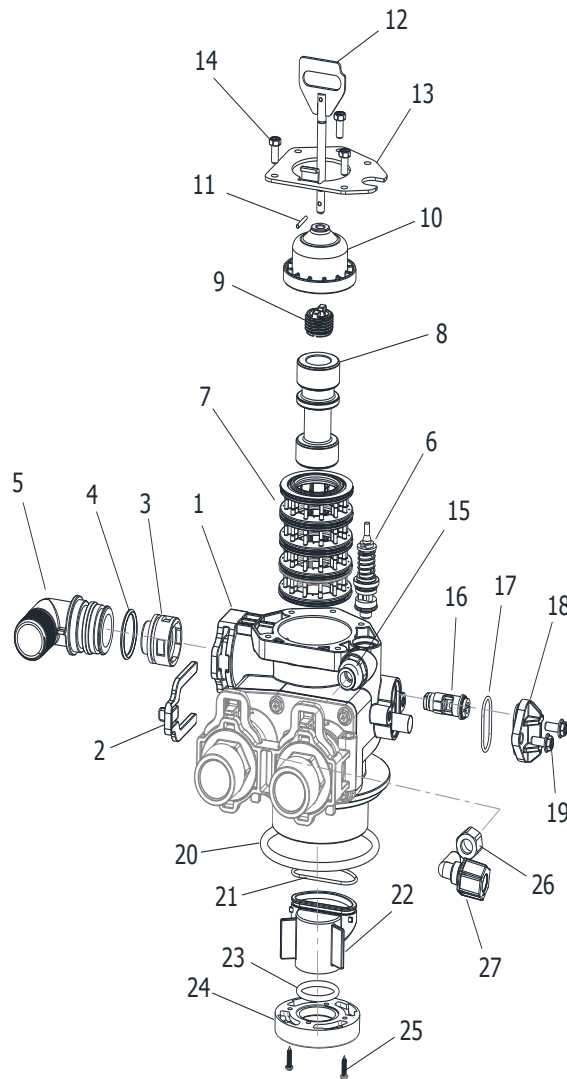

8	Three options of piston Down flow piston Up flow piston Filter piston	1
9	Piston retainer	1
10	End plug	1
11	Piston pin	1
12	Piston rod	1
13	<u>End plug retainer</u>	1
14	End plug retainer screws	3
15	Brine line adaptor assembly : optional BLFC : 0.7gpm BLFC : 0.95gpm	1
16	Injector assembly : optional grey, purple, red, white, blue, yellow	1
17	Injector cover O-ring	1
18	Injector cover	1
19	Injector cover screws	2
20	Tank mouth O-ring	1
21	Adapter O-ring	1
22	Center pipe adapter	1
23	Center pipe O-ring	1
24	Valve <u>bottom connector</u>	1
25	Bottom connector screws	2
26	Brass nuts	1
27	Brine line elbow assembly	1

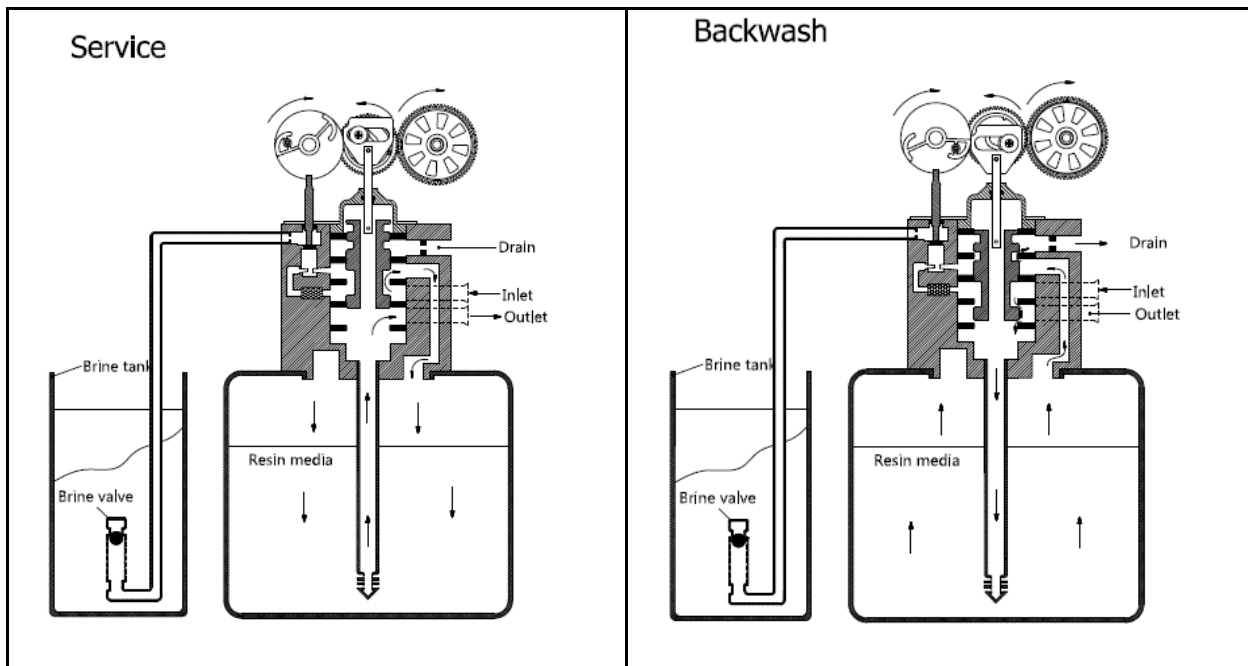

8	Three options of piston Down flow piston Up flow piston Filter piston	1
9	Piston retainer	1
10	End plug	1
11	Piston pin	1
12	Piston rod	1
13	End plug retainer	1
14	End plug retainer screws	3
15	Brine line adaptor assembly : optional BLFC : 0.7gpm BLFC : 0.95gpm	1
16	Injector assembly : optional grey, purple, red, white, blue, yellow	1
17	Injector cover O-ring	1
18	Injector cover	1
19	Injector cover screws	2
20	Tank mouth O-ring	1
21	Adapter O-ring	1
22	Center pipe adapter	1
23	Center pipe O-ring	1
24	Valve bottom connector	1
25	Bottom connector screws	2
26	Brass nuts	1
27	Brine line elbow assembly	1

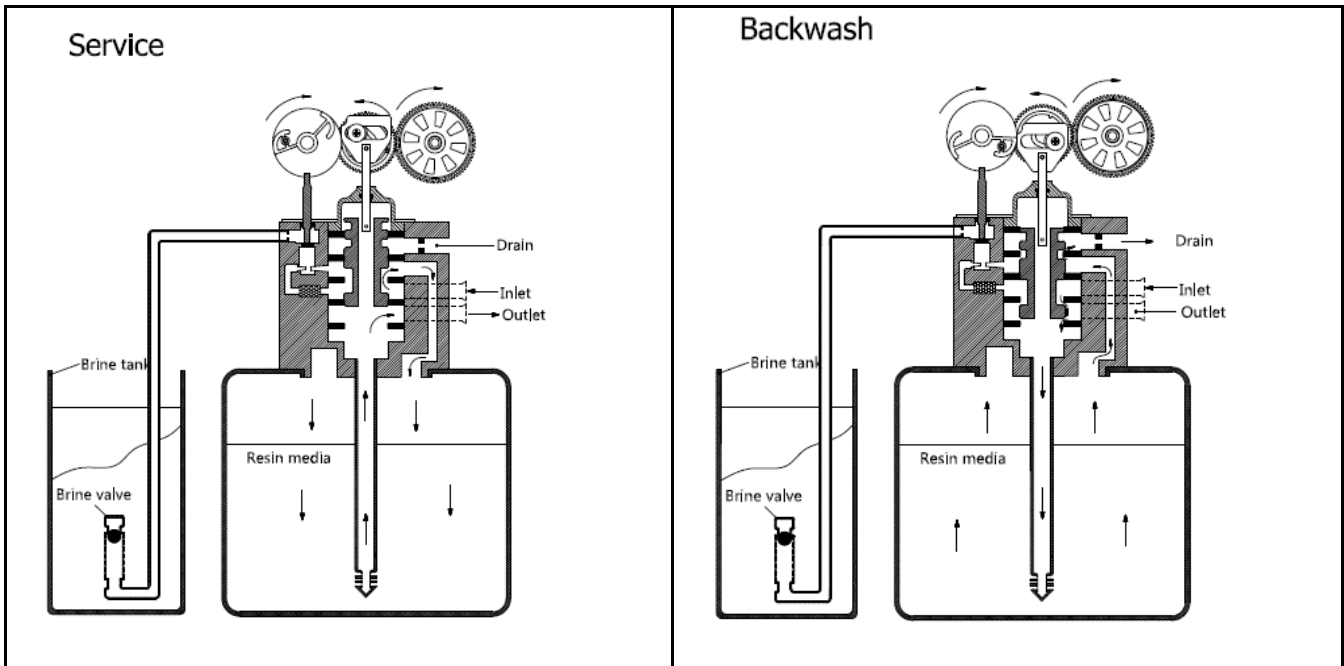



Limited Lifetime Warranty

For the lifetime of the original purchaser, at the original residential place of installation of this *Infusion* Water Conditioning System, *US WATER SYSTEMS, INC.* warrants the following:

LIFETIME COVERAGE

Media Tanks

Free of all costs to you except transportation and labor charges, we warrant that we will replace or repair the fiberglass media tank and the control valve body, if for any reason it is found to be defective, because of faulty materials or workmanship.

SEVEN YEAR COVERAGE

Head Assembly & Electronics

We warrant that for seven (7) years from the date of purchase, we will replace the head assemblies or electronic components at no charge to you except for transportation and standard labor charges. Electronics damaged due to environmental issues or improper installation is not covered. 100% full replacement for the first five (5) years and two (2) years pro-rated on the sixth and seventh year.

GENERAL PROVISIONS

This warranty does not apply to any commercial or industrial installations or to any part of the water conditioner which has been subjected to misuse, neglect, alteration or accident; or to any damage caused by fire, flood, freezing, Acts of God, or any other casualty, or if the original serial numbers have been removed.

These warranties are in lieu of all other warranties expressed, or implied, and we do not authorize any person to assume for us any other obligation on the sale of this water conditioner. No responsibility is assumed for delays or failure to meet these warranties caused by strike, government regulations or other circumstances beyond the control of *US WATER SYSTEMS, INC.*

TO OBTAIN WARRANTY SERVICE, CALL OR WRITE: *US WATER SYSTEMS, INC. 1209 COUNTRY CLUB ROAD INDIANAPOLIS, IN 46234 (800) 608-USWA.*

ANY IMPLIED WARRANTIES OF FITNESS OR MERCHANTABILITY ARE LIMITED TO THE TERMS OF THIS EXPRESSED WARRANTY AND THERE ARE NO WARRANTIES WHICH EXTEND BEYOND THOSE HEREIN. *US WATER* SHALL NOT BE LIABLE FOR ANY INCIDENTAL OR CONSEQUENTIAL DAMAGES.

SOME STATES DO NOT ALLOW THE EXCLUSION OR LIMITATIONS OF INCIDENTAL OR CONSEQUENTIAL DAMAGES SO THE ABOVE LIMITATION MAY NOT APPLY TO YOU. THIS WARRANTY GIVES YOU SPECIFIC LEGAL RIGHTS, AND YOU MAY ALSO HAVE OTHER RIGHTS WHICH VARY FROM STATE TO STATE.

THIS WARRANTY MAY BE TRANSFERRED TO A SUBSEQUENT OWNER WITH WRITTEN APPROVAL OF *US WATER* AND PAYMENT OF STANDARD TRANSFER FEE.