

USWater[™]
systems.com

Matrixx pH Balancing Backwashing Filter System

081-MXF-PH-XXX



Table of Contents

Unpacking and Inspection	3
Safety Guide	3
Before Starting Installation	4
Proper Installation	4
Tools, Pipe, Fittings, and Other Materials	4
System Dimensions	5
System Overview	6
Backwashing Filter Introduction	7
Where to Install the System	8
Preparation	9
Tank Preparation	9
Media Installation	9
Installation Instructions	13
System Regeneration	18
Normal Operation	18
Starting a Regeneration Cycle	18
Programming Using Onboard Buttons	19
Programming Using Legacy View App	20
Automatic Bypass During Regeneration	24
System Start Up	25
System Features	26
Replenishing the Calcite Media	28
Power Head Exploded View / Parts List	30
Bypass Exploded View / Parts List	31
Valve Body Exploded View / Parts List	32
Warranty	33

Unpacking and Inspection

Be sure to check the entire unit for any shipping damage or lost parts. Also note damage to the shipping cartons. Contact US Water Systems at 1-800-608-8792 to report any shipping damage within **24 hours of delivery**. Claims made after 24 hours may not be honored. Small parts, needed to install the unit, will be in a parts bag. To avoid loss of the small parts, keep them in the parts bag until you are ready to use them.

Safety Guide

- Check and comply with your provincial / state and local codes. You must follow these guidelines
- Use care when handling the system. Do not turn upside down, drop, drag, or set on sharp protrusions
- The backwashing filter uses 12 volt-60 Hz electrical power only. Be sure to use only the included transformer.
- Transformer must be plugged into an indoor 120 volt, grounded outlet only.
- **WARNING:** This system does not remove biological contaminants. US Water Systems recommends that bacteria levels be checked periodically to ensure there is no bacteria present. Coliform and E.coli most importantly.

Before Starting Installation

Proper Installation

This water filtering system must be properly installed and located in accordance with the Installation Instructions before it is used or the warranty will be void.

- **Do not** Install or store where it will be exposed to temperatures below freezing or exposed to any type of weather. Water freezing in the system will break it. Do not attempt to treat water over 100°F.
- **Do not** install in direct sunlight. Excessive sun or heat may cause distortion or other damage to non-metallic parts.
- Properly ground to conform with all governing codes and ordinances.
- Use only *lead-free solder and flux* for all sweat-solder connections as required by state and federal codes.
- Maximum allowable inlet water pressure is 100 psi. If daytime pressure is over 80 psi, night time pressure may exceed the maximum. Use a pressure reducing valve (PRV) to reduce the pressure.
- **Warning:** Discard all unused parts and packaging material after installation. Small parts remaining after the installation could be a choke hazard.

Tools, Pipe, Fittings, and Other Materials

- Channel Locks
- Screwdriver
- Teflon Tape
- Razor Knife
- Two adjustable wrenches
- Additional tools may be required if modification to home plumbing is required.
- To maintain full valve flow, be sure the plumbing size matches the size of the valve. The outlet pipe should be the same size or larger than the water supply pipe.
- Use copper, brass, or PEX pipe and fittings. Some codes may also allow PVC Plastic pipe.
- **ALWAYS** install the included bypass valve or install a 3 shut-off valve hard piped bypass. Bypass valves allow the water to be turned off to the system but can still provide water to the house for water use during repairs or service.
- 5/8" OD, 1/2" ID drain line is needed for the valve drain.

System Dimensions

Model	Tank Size	A	B	C
MXF-PH-150	10" X 54"	61.00"	55.25"	10"
MXF-PH-250	13" X 54"	61.00"	55.25"	13"

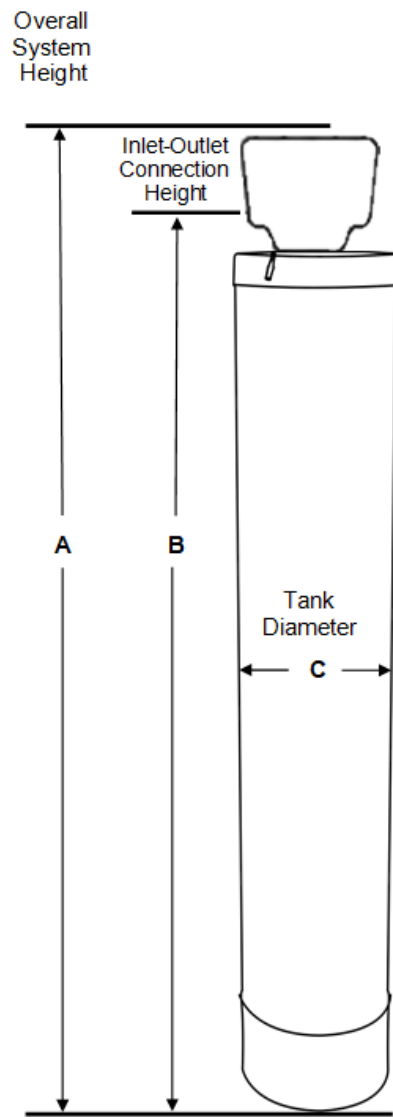

System Overview

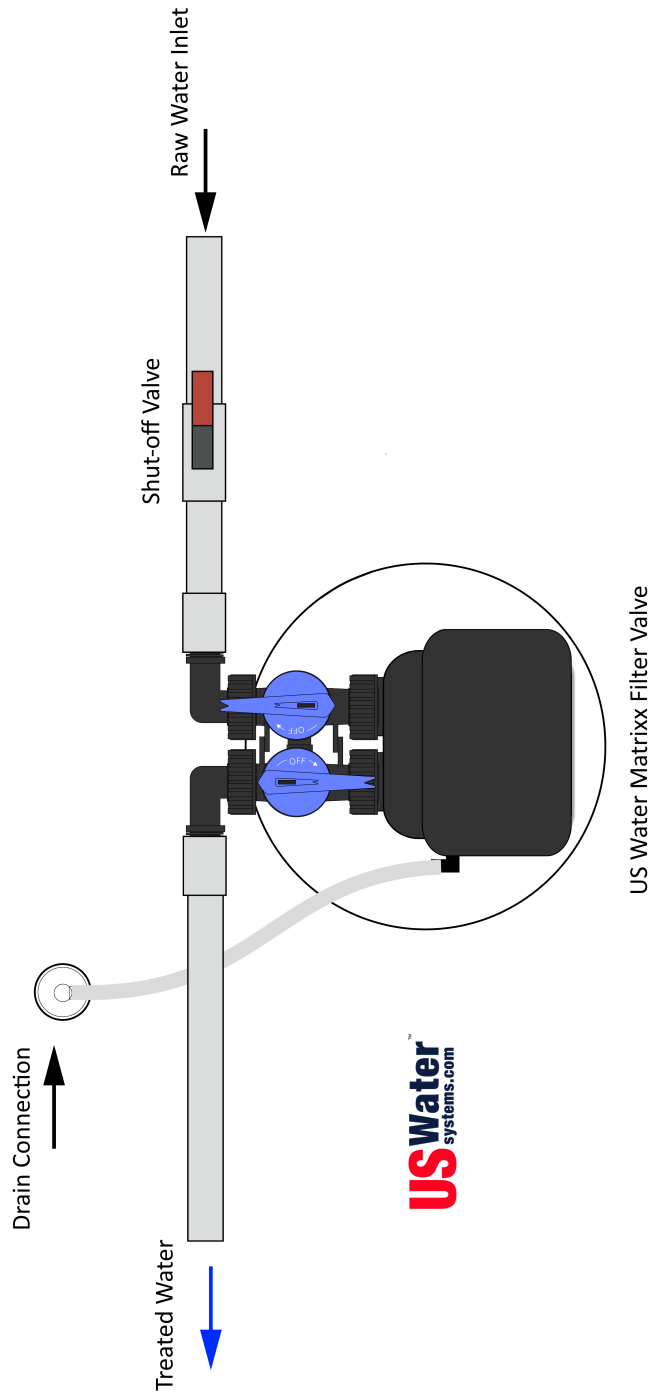

Backwashing Filter Introduction

The pH Balancing filter with calcite is designed to raise the pH of the water in cases of low pH (acid water conditions). It also adds some calcium hardness back to the water, and only requires periodic backwashing. Many areas of the country have water with low pH. A low pH means that the water is acidic and can corrode copper pipes and cause blue-green stains on plumbing fixtures in your home. The pH Balancing system is designed to neutralize the acid balance of your water supply. It does this by using calcite which is crushed and screened white marble limestone. If your pH is below 5.8, then we recommend a blend of calcite and magnesium oxide. Calcite and magnesium oxide will increase hardness in the water and a water softener may become necessary after the neutralizing filter.

Calcite is a naturally occurring calcium carbonate media. One of the advantages of calcite is its self-limiting property. When properly applied, it corrects pH only enough to reach a non-corrosive equilibrium. It does not over correct under normal conditions. Upon contact with calcite, acidic waters slowly dissolve the calcium carbonate to raise the pH which reduces potential leaching of copper, lead and other metals found in typical plumbing systems. Periodic backwashing will prevent packing, reclassify the bed and maintain high service rates. Depending on the pH, water chemistry and service flow, the calcite / magnesium oxide bed will have to be periodically replenished as the calcite is depleted.

The pH Balancing filter is a fully automatic backwashing filtration system. It uses all NSF and FDA approved components, including the calcite. The electronic computer control redistributes the media bed to prevent channeling.

FEATURES

- Electronic controller has only one internal moving part - simple to set
- No complicated programs
- Includes built-in bypass valve
- 12 volt electrical system uses less than \$2.00 electricity per year
- No danger of electrical shock
- Extremely user friendly
- Low maintenance due to automatic operation
- Lifetime Tank Warranty - 10 Years on Valve & Electronics (Includes Internal Parts)

Where to Install the System

- Place the unit in the treatment system where needed after the pressure tank of a well system or after the water main metering system.
- Place the system as close as possible to a floor drain or other acceptable drain point (laundry tub, sump, standpipe, etc)
- Connect the unit to the water system **BEFORE** the water heater (10' or more). **DO NOT RUN HOT WATER THROUGH THE SYSTEM.** Temperature of water passing through the system must be less than 100°F.
- Do not install the system in a place where it could freeze. **Damage caused by freezing is not covered by the warranty.**
- Put the system in a place where water damage is least likely to occur if a leak develops. **The manufacturer will not repair or pay for water damage.**
- A 120 volt electric outlet is needed within 6 ft of the system. The transformer has an attached 6 foot power cable. **Be sure the electrical outlet and transformer are in an inside location so they are protected from wet weather.**
- If installing in an outside location, you must take the steps necessary to ensure the system, installation plumbing, wiring, etc are protected from the elements and contamination sources.
- **Keep the system out of direct sunlight.** The sun's heat may soften and distort plastic parts.

Preparation

Tank Preparation

Water Pressure: A minimum of 20 pounds of water pressure is required for the regeneration valve to operate effectively.

Electrical Facilities: An uninterrupted alternating current (AC) supply is required. *Note: Other voltages are available. Please make sure your voltage supply is compatible with your unit before installation.*

Existing Plumbing: Condition of existing plumbing should be free from lime and iron buildup. Piping that is built up heavily with lime and/or iron should be replaced.

Location of Tank and Drain: The media tank should be located close to a drain to prevent air breaks and back flow.

Caution: Water pressure is not to exceed 80 psi, water temperature is not to exceed 110°F (43°C), and the unit cannot be subjected to freezing conditions.

Media Installation

1. Remove the tank from the carton.
2. Verify the riser tube is centered in the bottom of the tank. There is an indentation in the bottom of the tank that will allow the distributor tube to be centered. A flashlight may be needed to verify the tube is in the center of the tank.



3. Install the clear, plastic cap that is provided in the install kit onto the distributor tube.

4. Use the funnel provided to pour the media into the tank. The order the media is poured in is important. Begin by pouring the Quartz Gravel into the bottom of the tank. Pour it evenly around the hole to ensure it is well distributed in the tank and pour slow enough to keep from plugging the hole. Then proceed to pour the Calcite. A helper may be needed to hold the funnel during the filling process.
NOTE: It is recommended that a dust mask and safety goggles be worn to prevent possible injury.
5. When the media is installed, move the tank side to side to settle the media. Remove the funnel and cap from the distributor tube.

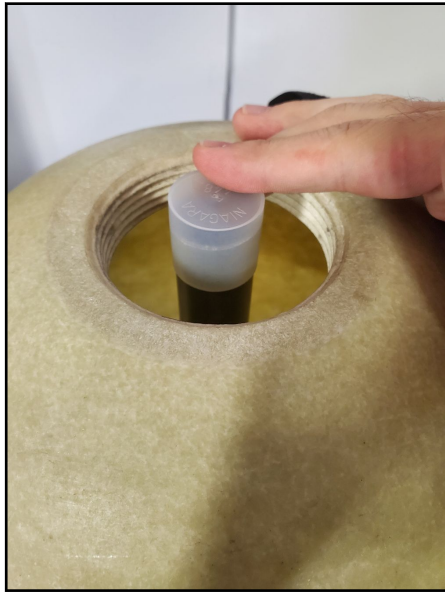

6. Lubricate the distributor O-ring and the outer tank O-ring.



7. Install the upper basket on the bottom of the valve by lining up the tabs then turning the basket clockwise to lock it in place. Place the upper basket over the distributor tube and push the valve onto the tank. Thread the valve on the tank by turning it clockwise. Be sure not to cross thread the valve on the tank.



8. Tighten the valve hand tight then snug it further by tapping it with the palm of the hand. **DO NOT** use tools to tighten the valve or damage could occur.

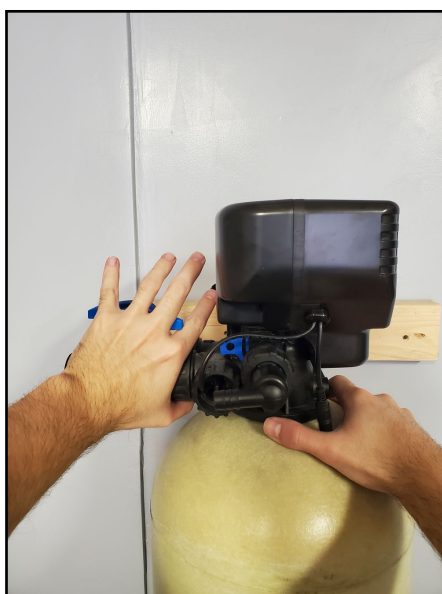

Installation Instructions

1. If your hot water tank is electric, turn off the power to it to avoid damage to the element in the tank.
2. If you have a private well, turn the power off to the pump and then shut off the main water shut off valve. If you have municipal water, simply shut off the main valve. Go to a faucet or spigot (preferably on the lowest floor of the house) and turn on the cold water until all pressure is relieved and the flow of water stops.
3. Locate the backwashing tank close to a drain where the system will be installed. The surface should be clean and level.

NOTE: Any solder joints being soldered near the valve must be done before connecting any piping to the valve. Always leave at least 6" (152 mm) between the control valve and joints being soldered when soldering pipes that are connected to the valve. Failure to do this could cause damage to the valve.

The system is equipped with male pipe threaded ports on the control valve bypass. The bypass is marked with arrows to show proper flow direction. The arrow pointing toward the valve indicates the inlet. The arrow pointing away from the valve is the outlet.



4. Insert the provided plumbing fittings into the bypass. 3/4" and 1" male pipe thread fittings are supplied so ensure you pick the correct one for your plumbing. Tighten the retaining nuts hand tight, ensuring that the fittings are not cross threaded.



5. Be sure to use Teflon tape or other pipe sealant on the plumbing fitting threads and install them on the bypass accordingly. Use an adjustable wrench to ensure they are tight.



NOTE: All piping should be secured to prevent stress on the bypass valve and connectors.

NOTE: Connections above are made using a stainless steel flex connector with a rubber gasket and do not require Teflon tape.

6. Connect the drain hose to the valve and secure it with a hose clamp. Run the drain hose to the nearest laundry tub, floor drain or approved air gap fitting. The drain can be ran overhead or down along the floor. Drain tubing should be a minimum of 1/2" ID. When running the drain overhead, it is important that the tubing has no dips or kinks. If the drain is ran overhead and must run linearly to the available drain, it is recommended that a hard pipe is used of larger diameter than the drain line. This linear pipe should have a physical "drop" toward the drain (1/2" : 10'). The goal is to have a gravity drain without much back pressure when traveling long distances.

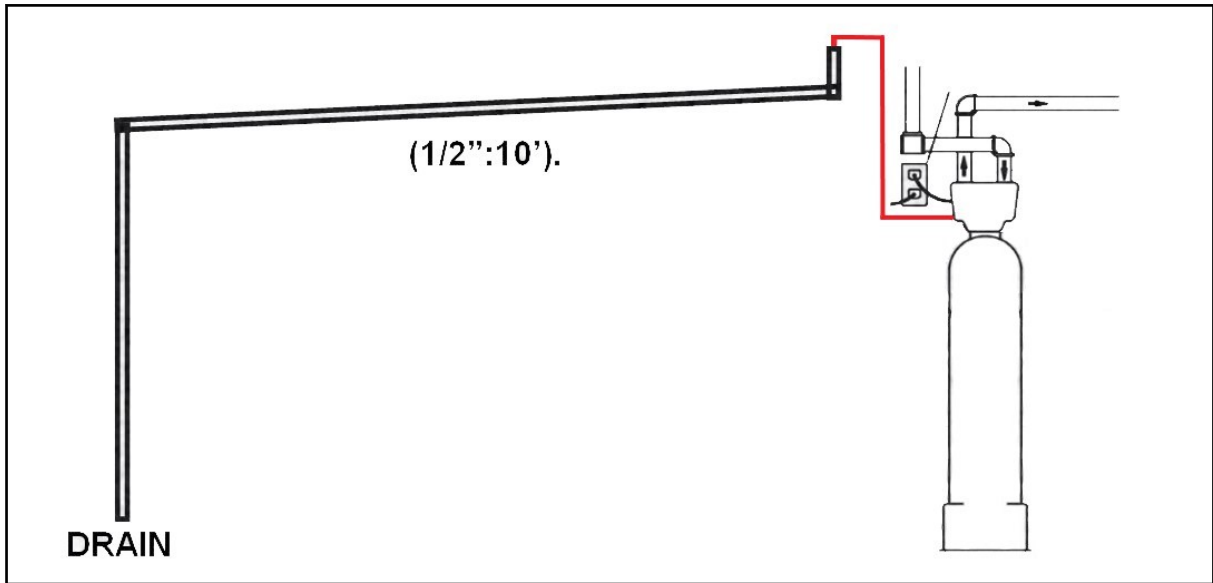

NOTE: A direct connection into a waste drain is not recommended. A physical air gap of at least 1.5" should be used to avoid bacteria and wastewater traveling back through the drain line into the system.

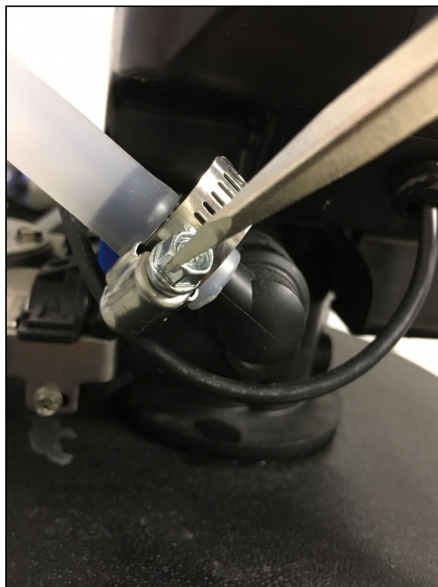

NOTE: Be sure to secure the drain line. The system will drain with force and it should be secured to prevent a leak. Hose clamps should be used to secure the drain line at the connection points.

7. Turn both bypass handles so they are perpendicular to the bypass to place the unit in the bypass position. Slowly turn on the main water supply. At the nearest cold treated faucet or spigot, open the faucet and let water run a few minutes or until the system is free of any air or foreign material resulting from the plumbing work. If a faucet is used, make sure the screen is removed first.



8. Make sure there are no leaks in the plumbing system before proceeding. Close the water tap when water runs clean. Check for leaks again.
9. Proceed to start up instructions

NOTE: The unit is not ready for service until you complete the start up instructions

System Regeneration

Normal Operation

Home Display - The home display will alternate between the time of day and gallons left until the next regeneration. The meter will count down to zero (0000) and then regenerate at the scheduled time set.

Starting a Regeneration Cycle

1. To Start **Delayed Extra Cycle**
 - If Days Remaining Until Next Regeneration does not read '0000', press and hold the Set/Change button for 3 seconds until the display reads '0000'
 - Regeneration cycle will initiate at the next designated regeneration time.
2. To start **Immediate Extra Cycle**, first complete above step.
 - With Gallons Remaining Until Next Regeneration at '0000', press and hold the **Set/Change** button.
 - After 3 seconds, the regeneration cycle will begin.
3. To **Fast Cycle** thru regeneration, first complete above 2 steps.
 - Press and hold the Set/Change button for 3 seconds to advance to the next cycle step. Fast Cycle is not necessary unless desired to manually step through each cycle step. (Repeat until valve returns to home display)

Filter Cycles		Default (Min)
Step 1	Backwash	10
Step 2	Rest	2
Step 3	Rinse	10

Programming Using Onboard Buttons



1. To enter the Main Menu, press the **Menu/Enter** button. (Time of Day will flash)
2. To set the **Time of Day**, press the **Set/Change** button. (First digit will flash)
 - To change digit value, press the Set/Change button.
 - To accept the digit value, press the Menu/Enter button.
 - Next digit will flash to begin setting.
 - Once the last digit display is accepted, all digits will flash.
3. To set **A.M. or P.M.**, press the **Menu/Enter** button.
 - To change digit value, press the Set/Change button.
 - To accept the digit value, press the Menu/Enter button.
 - Once A.M. or P.M. is accepted, the next menu item will flash.
4. To set the number of days between backwash cycles (A), press the **Set/Change** button. Repeat instructions from Step 2
 - Maximum value is 29
 - If value is set to 0, automatic backwash will never occur
 - Default setting is 7 days for filters
5. To Exit Main Menu, press the **Menu/Enter** button.

NOTE: If no buttons are pressed for 60 seconds, the Main Menu will be exited automatically.

Programming Using Legacy View App

The Legacy View app allows the user to control every aspect of the water system from the convenience of a smart phone. The Legacy View app will allow the user to monitor usage history, change cycle times, start a regeneration and advance through a regeneration.

To use the Legacy View Bluetooth App:

1. Go to the App store on the phone to be used and search for "Legacy View".
2. Download the free Legacy View app.
3. Open the app to begin programming.
4. Once the app is open, it will begin scanning for control valves in the Bluetooth vicinity.

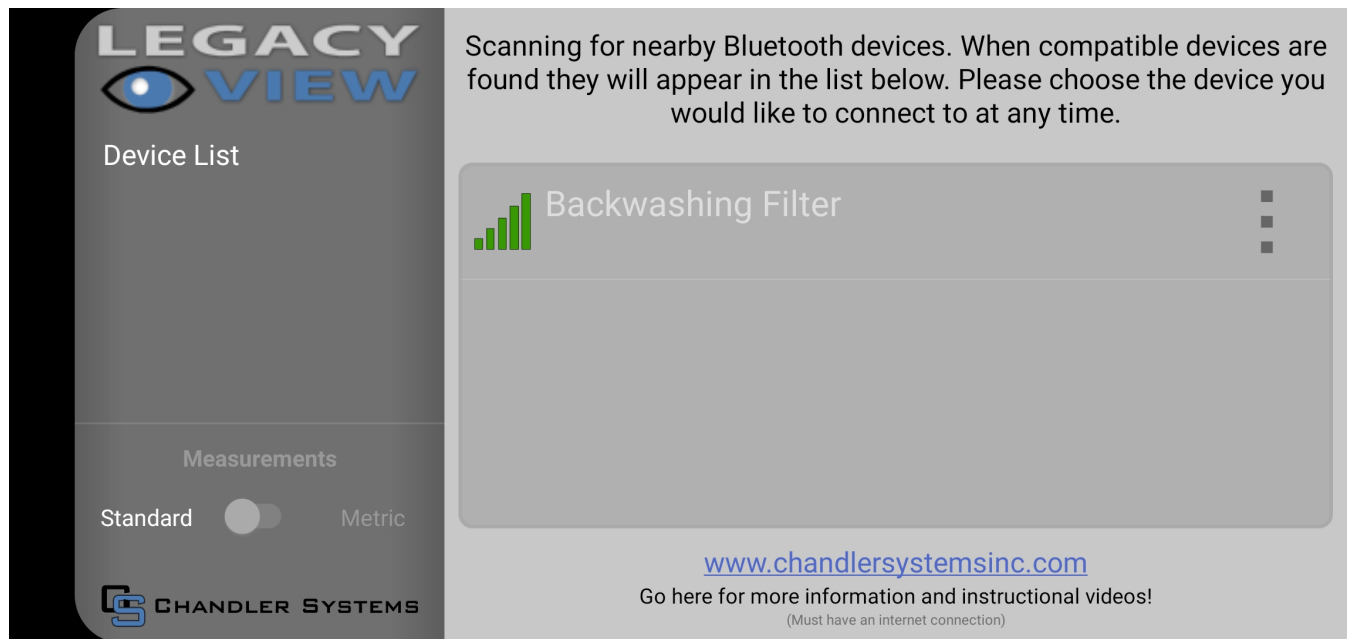

5. Once the app connects to the control valve or valves, they will appear on the screen. Each valve can be renamed by tapping on the three vertical dots on the valve listed on the screen. Choose "Label Device" and a lettered keyboard will appear. The user can name the valve using the keyboard then save it by pushing "OK".
6. Choose the valve to be programmed by tapping on the name. A "Dashboard" will show up for the control valve.

Dashboard



Parameters that can be changed are indicated with orange font. To change a parameter, tap on the orange font then use the keyboard that appears to change the value.

1. **Time of Day:** Tap on the "Time of Day" box. A box will appear that allows you to set the unit to the time that matches the device being used to program the unit. Press "OK" and the time will change to the current time of the device.
2. **Backwash Frequency:** Tap on the "Filter Backwash Frequency" box and input the desired days between backwashing. 7 Days is the recommended setting for this parameter.
3. **Regeneration Time:** Tap on the "Regeneration Time" box. Input the desired regeneration time for normal operation. This is typically two hours after everyone in the house is asleep or the business is closed for the day.

Advanced Settings

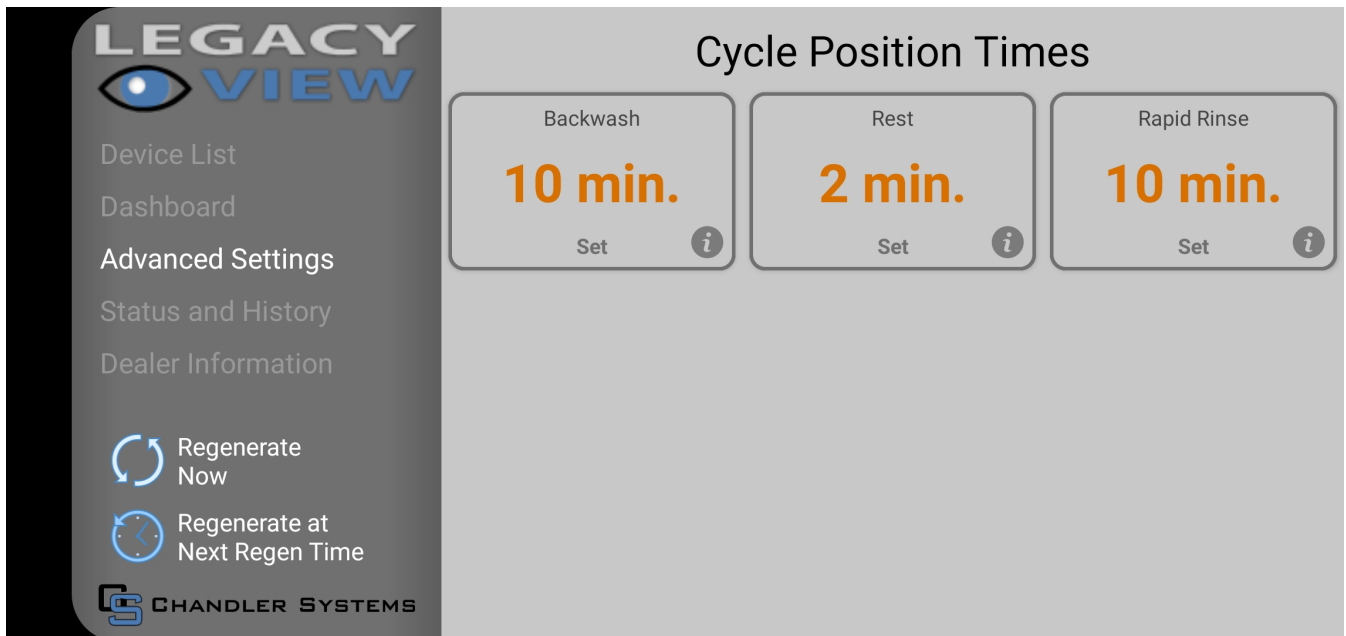

Parameters that can be changed are indicated with orange font. To change a parameter, tap on the orange font then use the keyboard that appears to change the value.

1. **Backwash:** This should be set to "10" min and should not be changed.
2. **Rest:** This should be set to "2" min and should not be changed.
3. **Rapid Rinse:** This should be set to "10" min and should not be changed.

Status and History

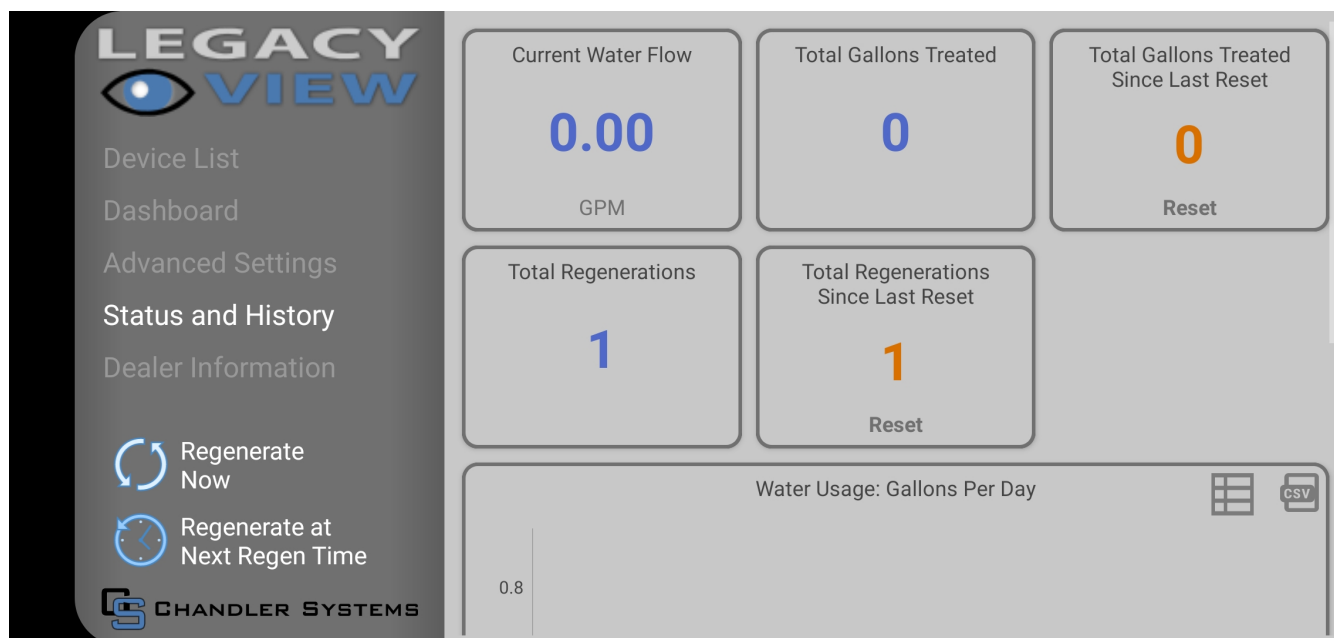

The Status and History screen shows current conditions of the system as well as flow rate and usage history. There are two parameters that can be reset.

1. **Total Regenerations:** This parameter shows how many times the system has regenerated since it was put in service or since the last time the value was reset.
2. **Total Water Treated:** This parameter shows the total amount of water that has been treated since the system was put in service or since the last time the value was reset.

Regenerating Using the Legacy View App

There are two options for regenerating the system. Tap on the desired option and press "OK".

1. **Regenerate Now:** Regenerate Now will queue an immediate regeneration and will start instantly.
2. **Regenerate at Next Regen Time:** Regenerate at Next Regen Time will queue the system to regenerate at the specified regeneration time chosen in the programming.

Automatic Bypass During Regeneration

The regeneration cycle can last 25 to 30 minutes, after which treated water service will be restored. During regeneration, untreated water is automatically bypassed for use in the household. This is why automatic regeneration is set for sometime during the night and manual regenerations should be performed when little or no water will be used in the household.

Manual Bypass

In the case of emergency, you can isolate your water system from the water supply using the bypass valve located at the back of the control. In normal operation, the bypass is open with the handles in line with the inlet and outlet pipes.

To isolate the system, simply rotate the handles clockwise (as indicated by the word OFF and arrow pointer on the handles) until they stop. Water can be used at related fixtures and appliances as the water supply is bypassing the system. The water used, however, will be untreated. To resume treated water service, open the bypass valve by rotating the handles counter clockwise.

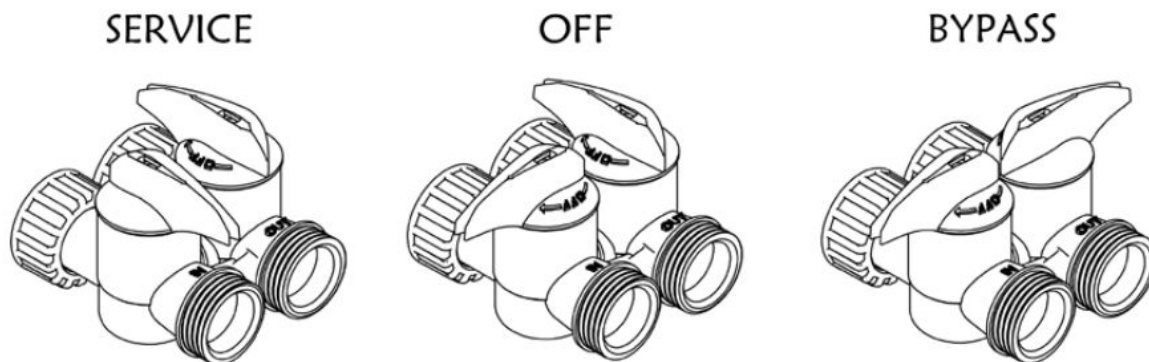

About The System

You may notice new sounds as your water system operates. The backwash cycle lasts up to 25 minutes. During this time, you may hear water running intermittently to the drain.

System Start Up

1. With the bypass handles in the bypass position, initiate an immediate regeneration. This will advance the valve to the backwash position.
2. Once the valve has stopped moving and is in the backwash position, slowly open the bypass handles about 1/8th turn. Water should slowly enter the tank.
NOTE: If there is a loud knocking sound, simply turn the bypass handle back slightly as the system is filling too quickly.
3. During the backwash cycle, slowly open the bypass valve until there is water coming out of the drain hose. Then open the bypass valve fully.
4. Allow the system to backwash and push all the air out through the drain.
5. The valve will automatically move to the rest cycle when the backwash cycle is complete. Skip this cycle by pressing and holding the "Set/Change" button on the control valve or by pressing "Go to Next Regen Step" on the Legacy View App.
6. This will move the valve to Rapid Rinse. Allow the unit to rinse for the entire cycle. The water in the drain should be running clear by the end of the Rapid Rinse Cycle.
7. The valve will then advance to Service.
8. Once the system has returned to the Service position, the system is installed and ready for use.

System Features

Battery Back-Up (Uses a standard 9-volt alkaline battery.)

- During power failures, the battery will maintain the time of day as long as the battery has power. The display is turned off to conserve battery power during this time. To confirm that the battery is working, press either button and the display will turn on for five (5) seconds.
- If power failure occurs while the system is regenerating, the control valve will motor to a shut off position to prevent constant flow to drain. Depending upon the system pressure and other factors, it is possible to observe a reduced flow to drain during this step. After power is restored, the control valve will return and finish the cycle where it left off prior to the power interruption.
- When used without battery back-up, during a power failure, the unit stops at its current point in the regeneration position and then restarts at that point when the power is restored. The time will be offset by the increment of time the unit was without power so it is necessary to reset the time of day on the unit. No other system will be affected.

WARNING: DO NOT INSTALL THE BATTERY BACKUP UNTIL THE SYSTEM HAS BEEN PROGRAMMED AND START UP IS COMPLETE!

1. Remove the two screws on the back of the valve.



2. Pull out the 9V battery connector, remove the battery cover, and attach the battery to the connector.



3. Push the battery back in the holder on the valve and replace the cover and screws.



Replenishing the Calcite Media

1. Put the unit in bypass then initiate a manual regeneration. This will release the pressure from the system.
2. Slowly open the dome hole on the top of the tank. Some water will come out so be prepared with a bucket and some towels for fast clean up.

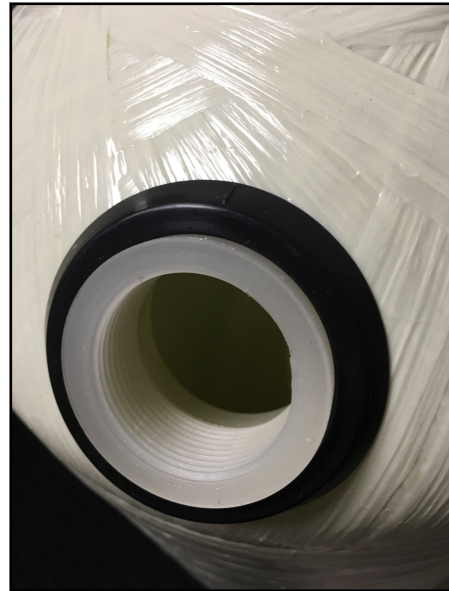

3. Now use a wet vac (Be sure to remove the dry filter) to remove the water from the top of the tank. Be sure not to remove any media while removing the water on top of the media.
4. Now pour the new calcite in the tank. **DO NOT** overfill the tank. There should be about 10" - 12" of open space in the top of the tank. This open space must be in the tank for the unit to backwash properly.

5. Lubricate the O-ring on the dome hole plug and install the dome plug in the dome hole.



6. Tighten it hand tight then snug it an additional 1/4 to 1/2 turn.
CAUTION: DO NOT overtighten the plug. This can cause damage to the dome hole and the tank.
7. The control valve should be back to the service position at this point. If not, advance the valve to the service position.
8. Once in the service position, initiate a manual regeneration.
9. When the valve moves to the backwash position and stops, slowly open the bypass valve and allow the water to refill the tank. Continue to open the valve slowly until it is fully open and no air is coming from the drain.
NOTE: If there is a loud knocking noise, then slow the water fill into the tank. This is air trying to escape the tank.
10. Allow the unit to continue to backwash and rinse until the water going to the drain runs clear.
NOTE: If the water coming out of the drain is still cloudy at the end of the first backwash and rinse, repeat the process and check the water again.
11. Once the drain line is running clear, the system is ready for use.

Power Head Exploded View / Parts List

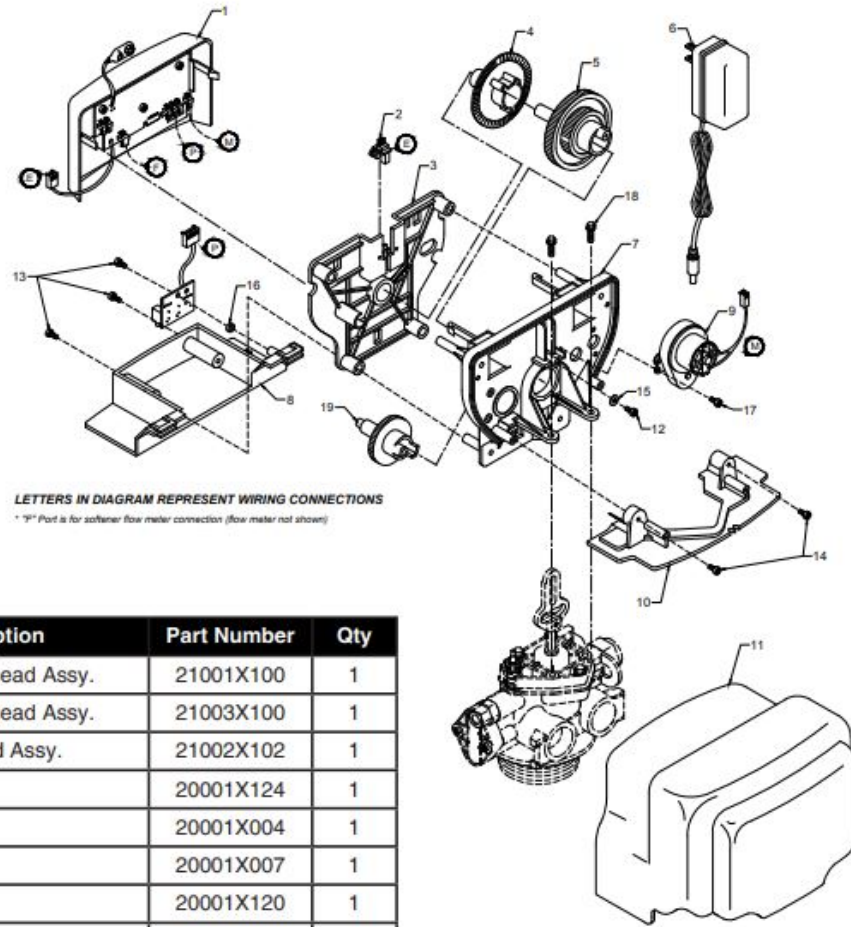

Ref	Description	Part Number	Qty
0	Timered Power Head Assy.	21001X100	1
0	Metered Power Head Assy.	21003X100	1
1	Filter Circuit Boad Assy.	21002X102	1
2	Encoder	20001X124	1
3	Front Plate	20001X004	1
4	Encoder Wheel	20001X007	1
5	Main Gear	20001X120	1
6	Power Supply	20001X125	1
7	Back Plate	20001X005	1
8	Lower Front Base For Cover	20111X002	1
9	Motor		1
10	Lower Back Base for Cover	20111X003	1
11	Valve Cover	20111X000	1
12	Piston Screw	20001X007	1
13	Screw	SC10	3
14	Screw	SC9	3
15	Piston Washer	20001X002	1
16	Washer Circuit Board	20111X014	1
17	Screw Motor	SC2	1
21	Valve Hex Screw	20001X001	2

Bypass Exploded View / Parts List

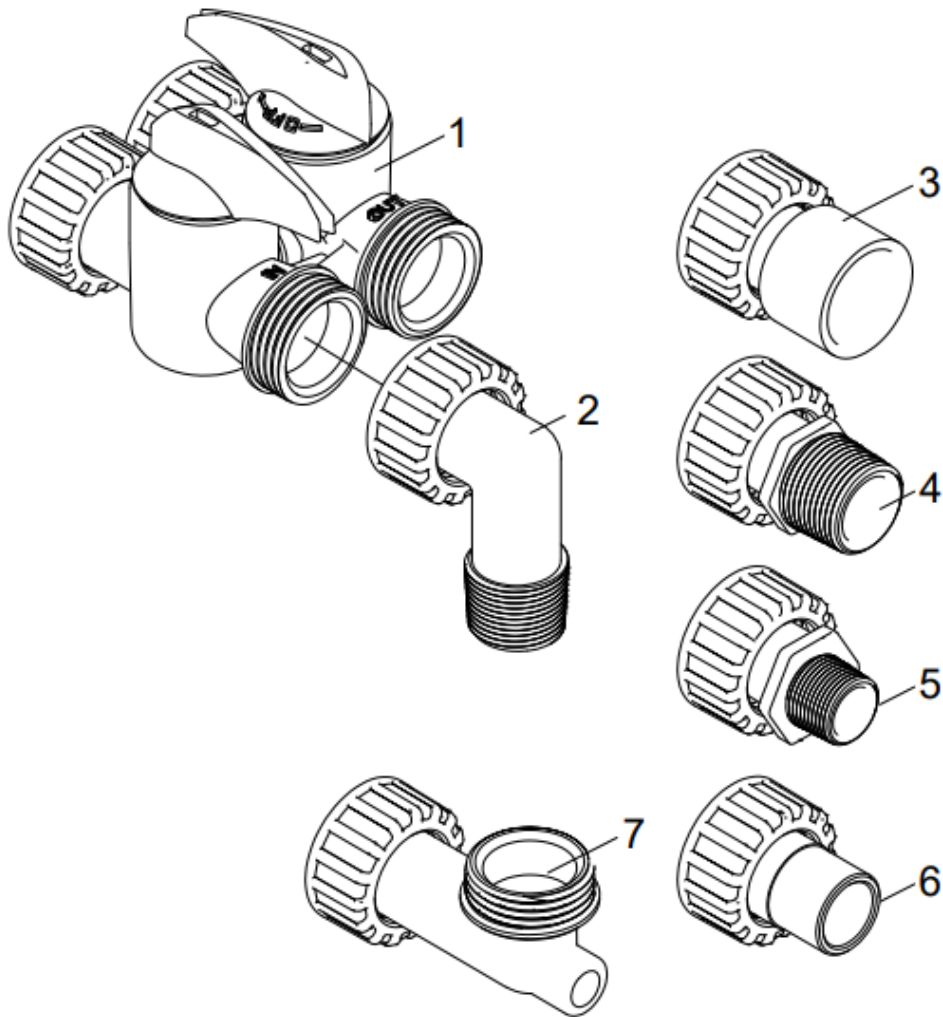

REF	Description	Part No.
1	D15 Bypass	085-PBP
2	1" NPT Elbow Set	085-PBP-ELL-100
3	1" Female Straight Slip Set	085-PBP-SJ-100
4	1" NPT Straight Set	085-PBP-100
5	3/4" NPT Straight Set	085-PBP-075
6	3/4" Female Straight Slip Set	085-PBP-SJ-075
7a	Elbow, Vertical Adapter (Blank)	085-PBPA-BL
7b	Elbow, Vertical Adapter (1/4" NPT Tapped)	085-PBPA-025

Valve Body Exploded View / Parts List

REF	Description	Part No.	QTY
1	Piston Assembly	085-MX-SFP	1
2	10-24 X 3/4" Screw SST	311-1024-34	3
3	Seal and Spacer Kit Incl (5) #3 & (4) #4	085-MX-SS	1
4	End Spacer	N/S	1
5	Flow Control Button 5.0 GPM	085-DLFC-50	1
	Flow Control Button 7.0 GPM	085-DLFC-70	1
6	DLFC Assy.	085-DLFC-ASSY	1
7	90 Degree Hose Barb Elbow	085-MX-DLF	1
8	Drain Retainer	085-DLFC-RTN	1
9	Brine Valve Plug w/ O-Ring	085-PLUG-BV	1
10	Filter Plug Assy w/ O-Ring	085-PLUG-FL	1
11	10-24 X 3/4" Screw SST	311-1024-34	2
12	Injector Cap	085-INJ-CAP	1
13	Injector Seal	085-INJ-SEAL	1
14	Injector Plug & O-Ring Assy	085-INJ-PL	1
15	Injector Screen	085-INJ-SC	1
16	Injector Plug & O-Ring Assy	085-INJ-PL	1
17	Valve O-Ring	085-FXO-CV-ORING	1
18	Dist O-Ring	085-DIST-ORING	1
19	Meter Assembly	085-METER-ASSY	1

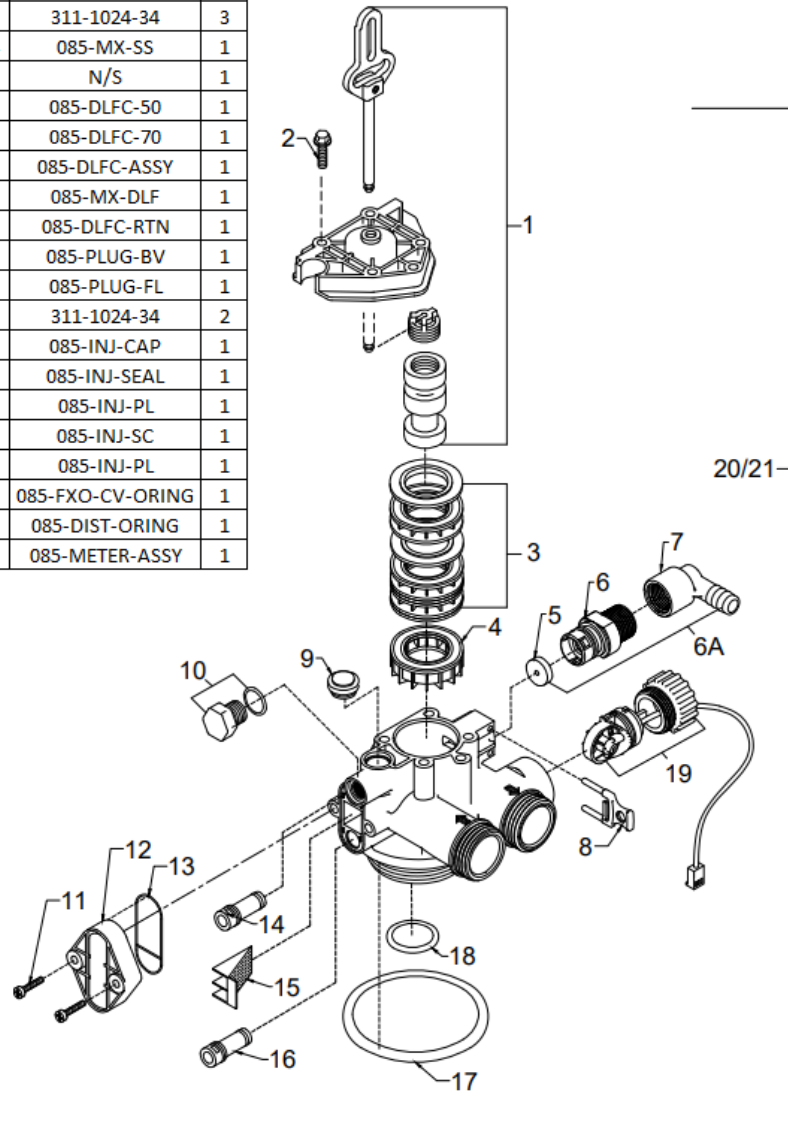

Warranty

MATRIX BACKWASHING FILTER LIMITED WARRANTY

US Water Systems, Inc. (“US Water Systems”) warrants that your new water treatment system is built of quality material and workmanship. When properly installed and maintained, it will give years of trouble-free service. TO PLACE THIS EQUIPMENT UNDER WARRANTY, THE WARRANTY REGISTRATION MUST BE COMPLETED AND RETURNED BY THE ORIGINAL OWNER TO US WATER SYSTEMS, INC. WITHIN 30 DAYS OF INSTALLATION.

Coverage - This limited warranty covers the Matrixx Backwashing Filter (the “System” hereafter) delivered to the original owner when the appliance is purchased for personal, family, or household use. It is intended to cover defects occurring in workmanship or materials or both. US Water Systems warrants that upon receipt from the owner of any Media Tank or Main Control Valve incorporated into the System found to be defective in material or workmanship, US Water Systems will repair or replace the defective item, at no charge for that item, under the procedures and limitations outlined below.

Ten Year System Parts Warranty - US Water Systems will replace any valve, electronics or miscellaneous part of the System, to any original purchaser of the System in possession of the System, which fails within ten (10) years from date of purchase, as indicated by the serial number, provided the failure is due to a defect in material or workmanship. THE DURATION OF THE

IMPLIED WARRANTIES OF FITNESS OR MERCHANTABILITY AS THEY APPLY TO THE PARTS OF THE SYSTEM COVERED BY THIS PARAGRAPH OF THE LIMITED WARRANTY ARE LIMITED TO THE DURATION OF THE LIMITED WARRANTY SET FORTH IN THIS PARAGRAPH.

Lifetime Warranty on Media Tank - US Water Systems will replace the mineral tank of the System, to any original purchaser of the System in possession of the System, which fails if the System was at all times operated in accordance with specifications set forth in the System’s handbook and not subject to freezing and other general limitations about the System. THE DURATION OF THE IMPLIED WARRANTIES OF FITNESS OR MERCHANTABILITY AS THEY APPLY TO THE PARTS OF THE SYSTEM COVERED BY THIS PARAGRAPH OF THE LIMITED WARRANTY ARE LIMITED TO THE DURATION OF THE LIMITED WARRANTY SET FORTH IN THIS PARAGRAPH.

General Provisions - US Water Systems assumes no responsibility for subsequent or consequential damage, labor or expense incurred as a result of a defect or for failure to meet the terms of this limited warranty because of circumstances beyond its control. Installation workmanship failure is not covered under this limited warranty. Damage caused by environmental conditions such as, fire, freezing, accidents, unreasonable use, abuse, neglect, lightning strikes, humidity or heat is not covered under this limited warranty. It is the responsibility of the customer to pay any and all shipping

charges for the return or replacement of any part covered under this limited warranty. In the event the water supply being processed through the System contains sand, bacterial iron, algae, sulfur, tannins, organic matter, high levels of chlorine or chloramine, methane, or other unusual substances, then unless the owner's manual or appliance specifications for the System provides that the System is capable of handling these substances, other special treatment of the water supply must be used to remove these substances before they enter the System. Otherwise, US Water Systems shall have no obligations under this limited warranty. This limited warranty does not cover damage to a part or parts of the System resulting from improper installation. All plumbing and electrical connections should be made in accordance with all local codes and the installation instructions provided with the System. The limited warranty does not cover damage resulting from use with inadequate or defective plumbing; inadequate or defective water supply or high or low pressure; inadequate or defective house wiring; improper voltage, electrical service, or electrical connections; or violation of applicable building, plumbing, or electrical codes, laws, ordinances, or regulations.

US Water Systems does not authorize any person to assume for us any other obliga-

tion on the sale of this water system. No responsibility is assumed for delays or failure to meet this limited warranty caused by strike, government regulations or other circumstances beyond the control of US WATER SYSTEMS, INC. To obtain warranty service, call or write: US WATER SYSTEMS, INC. 1209 Country Club Road Indianapolis, IN 46234 (800-608-8792). THIS LIMITED WARRANTY IS IN LIEU OF ALL OTHER WARRANTIES, EXPRESS OR IMPLIED, AND ANY IMPLIED WARRANTIES OF FITNESS OR MERCHANTABILITY ARE LIMITED TO THE TERMS OF THIS LIMITED WARRANTY, AND THERE ARE NO WARRANTIES WHICH EXTEND BEYOND THOSE HEREIN. US WATER SYSTEMS SHALL NOT BE LIABLE FOR ANY INCIDENTAL OR CONSEQUENTIAL DAMAGES. Some states do not allow the exclusion or limitations of incidental or consequential damages so the above limitation may not apply to you. This limited warranty gives you specific legal rights, and you may also have other rights which vary from state to state.

THIS LIMITED WARRANTY MAY BE TRANSFERRED TO A SUBSEQUENT OWNER WITH WRITTEN APPROVAL OF US WATER SYSTEMS AND PAYMENT OF STANDARD TRANSFER FEE.