

Visit us online at
www.uswatersystems.com

US Water
systems.com

Fusion NLT Hybrid Water Softener with Chlorine and Chloramine Removal



FUSION
NLT
next level technology

Owners Manual

Models:

087-FNLT-XXX-HY1

REVISION # 4.5
REVISION DATE May 12, 2015

US Water Systems Corporate Office
1209 Country Club Road
Indianapolis, IN 46234
1-800-608-8792
info@uswatersystems.com

Table of Contents

	PAGE
Unpacking / Inspection	3
Safety Guide	3
Proper Installation	4
Specification	7
Before Starting Installation	7
Installation Instructions	18
System Start Up	27
Programming Instructions	28
About The System	29
Maintenance	31
Sanitizing Procedure	35
Main Repair Parts	36
Trouble Shooting	41
Programming Chart	42
Warranty	43

Unpacking / Inspection

Be sure to check the entire softener for any shipping damage or parts loss. Also note damage to the shipping cartons. Contact US Water Systems at 1-800-608-8792 to report any shipping damage within 24 hours of delivery. Claims made after 24 hours may not be honored.

Small parts, needed to install the softener, are in a parts bag. To avoid loss of the small parts, keep them in the parts bag until you are ready to use them.

Safety Guide

For your safety, the information in this manual must be followed to minimize the risk of electric shock, property damage or personal injury.

- Check and comply with your provincial / state and local codes. You must follow these guidelines.
- Use care when handling the water softening system. Do not turn upside down, drop, drag or set on sharp protrusions.
- The water softening system works on 12 volt-60 Hz electrical power only. Be sure to use only the included transformer.
- Transformer must be plugged into an indoor 120 volt, grounded outlet only.
- Use clean water softening salts only, at least 99.5% pure. Extra Course Grade or Crystal salts are recommended. Do not use rock, block, granulated or ice cream making salts. They contain contaminants that could cause maintenance problems.
- Keep the salt lid in place on the softener unless servicing the unit or refilling with salt.
- **WARNING:** This system is not intended for treating water that is microbiologically unsafe or of unknown quality without adequate disinfection before or after the system. Contact US Water Systems for disinfection treatment equipment.

Proper Installation

This water softening system must be properly installed and located in accordance with the Installation Instructions before it is used or the warranty will be void.

- **Do not** install or store where it will be exposed to temperatures below freezing or exposed to any type of weather. Water freezing in the system will break it. Do not attempt to treat water over 100°F.
- **Do not** install in direct sunlight. Excessive sun or heat may cause distortion or other damage to non-metallic parts.
- Properly ground to conform with all governing codes and ordinances.
- Use only *lead-free solder and flux* for all sweat-solder connections, as required by state and federal codes.
- Maximum allowable inlet water pressure is 125 psi. If daytime pressure is over 80 psi, night time pressure may exceed the maximum. Use a pressure reducing valve to reduce the pressure.
- Softener resins may degrade in the presence of chlorine or chloramines above 2 ppm. If you have chlorine or chloramines in excess of this amount, you may experience reduced life of the resin. In these conditions, you may wish to consider purchasing a whole house carbon filter softener system with a chlorine reducing media. Contact US Water Systems for Chlorine and Chloramine removal equipment. Fusion Hybrid Water softeners can remove chlorine.
- **WARNING:** Discard all unused parts and packaging material after installation. Small parts remaining after the installation could be a choke hazard.

System Dimensions

Model	Tank Size	A	B	C
FNLT-100-HY	9" X 48"	61 7/8"	50 7/8"	9"
FNLT-150-HY	10" X 54"	67 7/8"	57"	10"
FNLT-200-HY	12" X 52"	65 7/8"	55 1/4"	12"
FNLT-250-HY	13" X 54"	67 7/8"	57 5/8"	13"

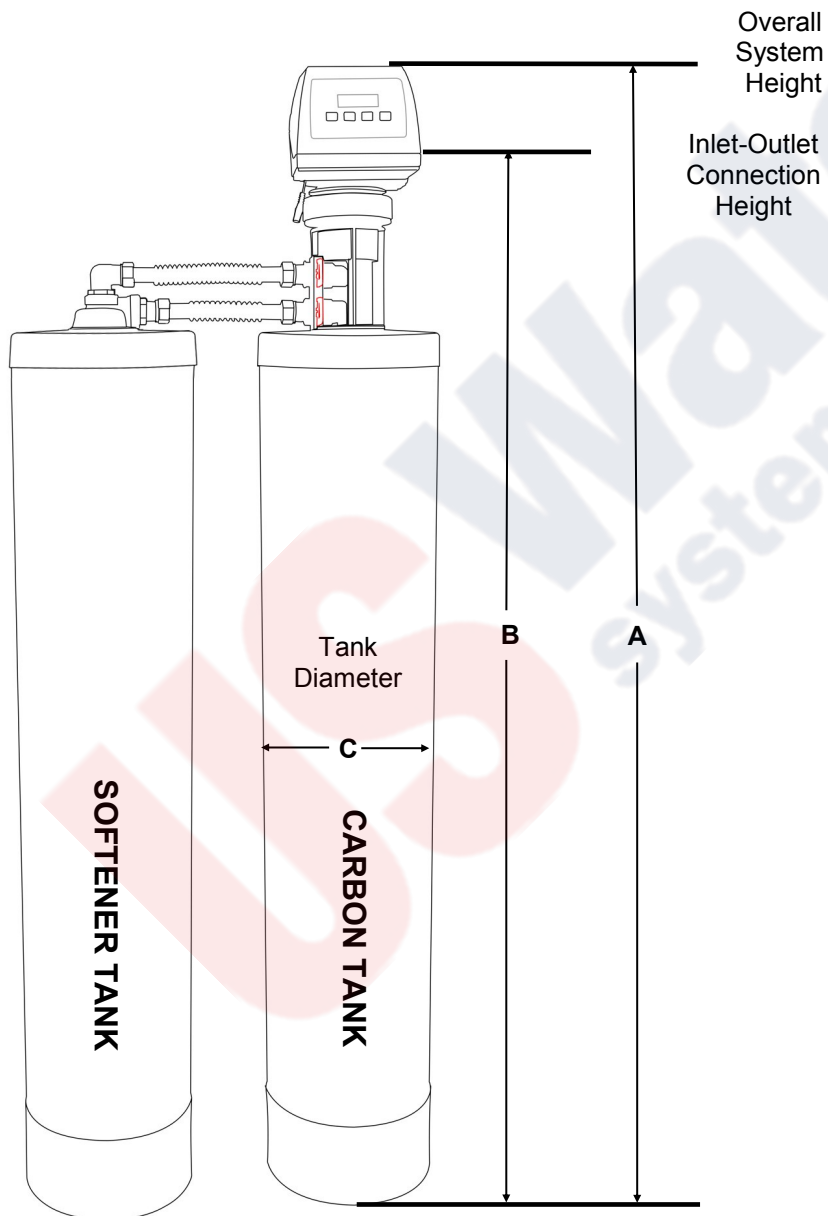

System Dimensions

15" Brine Tank

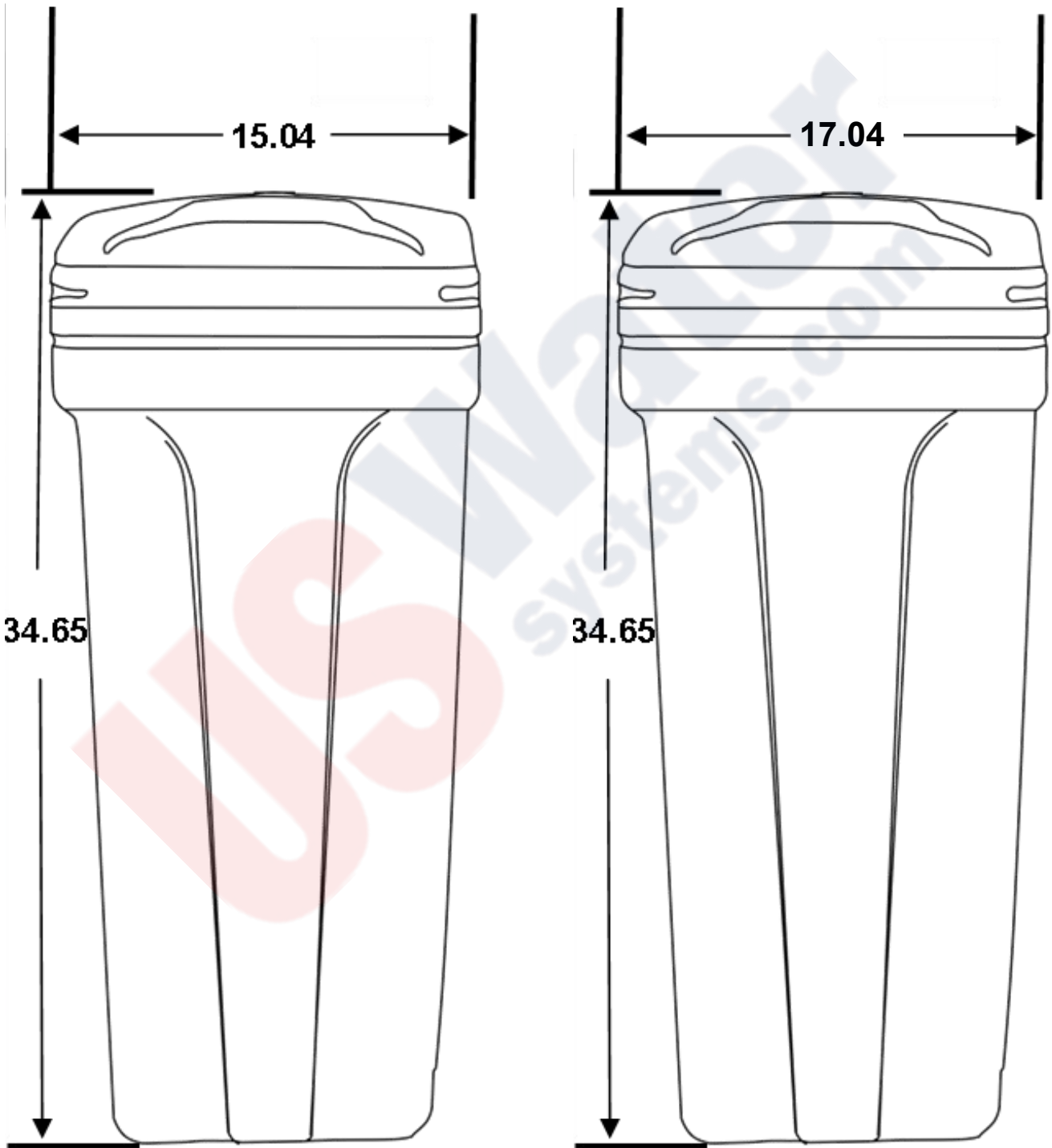

Specifications

Specifications	FNLT-100-HY1	FNLT-150-HY1	FNLT-200-HY1	FNLT-250-HY1
Maximum Capacity New (Not Optimal)	35,000 Grains/15lbs Salt	53,000 Grains/23lbs Salt	70,000 Grains/30lbs Salt	88,000 Grains/38lbs Salt
Optional Settings - High Efficiency				
Salt Used - Per Regeneration	3.0 lbs	4.5 lbs	6.0 lbs	7.5 lbs
Back Wash Override Selection	Without BW/With BW	Without BW/With BW	Without BW/With BW	Without BW/With BW
Water Used - Regeneration	101.7 Gal / 151.7 Gal	97.2 Gal / 147.2 Gal	127.2 Gal / 197.2 Gal	187.2 Gal / 297.2 Gal
Hardness Removal - Grains	15,000	22,500	30,000	37,500
Factory Settings - Standard Capacity				
Salt Used - Per Regeneration	6.0 lbs	9.0 lbs	12.0 lbs	18.0 lbs
Back Wash Override Selection	Without BW/With BW	Without BW/With BW	Without BW/With BW	Without BW/With BW
Water Used - Regeneration	106.5 Gal / 156.5 Gal	101.6 Gal / 151.6 Gal	131.6 Gal / 201.6 Gal	191.7 Gal / 301.7 Gal
Hardness Removal - Grains	24,600	36,900	49,200	61,500
Optional Settings - High Capacity				
Salt Used - Per Regeneration	12.0 lbs	18.0 lbs	24.0 lbs	30.0 lbs
Back Wash Override Selection	Without BW/With BW	Without BW/With BW	Without BW/With BW	Without BW/With BW
Water Used - Regeneration	113.4 Gal / 163.4 Gal	108.4 Gal / 158.4 Gal	138.4 Gal / 208.4 Gal	199 Gal / 309 Gal
Hardness Removal - Grains	30,000	45,000	60,000	75,000
Resin Quantity - Cubic Feet	1.0 CU/FT	1.5 CU/FT	2.0 CU/FT	2.5 CU/FT
Tank Size	9X48	10X54	12X52	13X54
Tank Jackets	YES	YES	YES	YES
Brine Tank/Cabinet Size (Inches)	15X17X35	15X17X35	15X17X35	15X17X35
Salt Storage Capacity	240 lbs	240 lbs	240 lbs	240 lbs
Flow Rate @ 15 PSI Pressure Drop	11.0 gpm	11.2 gpm	12.2 gpm	12.6 gpm
Flow Rate @ 25 PSI Pressure Drop	15 gpm	15.1 gpm	16.2 gpm	16.6 gpm
Peak Flow Rate	10 gpm	15 gpm	20 gpm	25 gpm
Back Wash Flow Rate	5 gpm	5 gpm	7 gpm	10 gpm
Plumbing Connections	3/4" or 1"			
Resin Type	10 % Cross-Linked Ion Exchange Resin/Carbon			
Electrical Requirements	Input 120V 60 Hz - Output 12V 650mA			
Water Temperature	Min 39 - Max. 100 degrees Fahrenheit			
Water Pressure	Min. 20 - Max. 125 PSI			

- Continuous operation at flow rates greater than the service flow rate may affect capacity and efficiency performance.
- The manufacturer reserves the right to make product improvements which may deviate from the specifications and descriptions stated herein, without obligation to change previously manufactured products or to note the change.
- The above capacity and flow rate specifications have not been validated by WQA.

Before Starting Installation

Tools, Pipe, and Fittings, Other Materials

- Channel Locks
- Screwdriver
- Teflon tape
- Razor knife
- Two adjustable wrenches
- Additional tools may be required if modification to home plumbing is required.
- Plastic inlet and outlet fittings are included with the softener. To maintain full valve flow, 1" pipes to and from the softener fittings are recommended. You should maintain the same, or larger, pipe size as the water supply pipe, up to the softener inlet and outlet.
- Use copper, brass, or PEX pipe and fittings.
- Some codes may also allow PVC plastic pipe.
- ALWAYS install the included bypass valve, or 3 shut-off valves. Bypass valves let you turn off water to the softener for repairs if needed, but still have water in the house pipes.
- 5/8" OD drain line is needed for the valve drain.
- A length of 5/8" OD drain line tubing is needed for the brine tank over flow fitting (optional).
- Extra Course Grade or Crystal water softener salt is needed to fill the cabinet or brine tank.

How Your Water Conditioner Works

The principle behind water softening is simple chemistry. A water softener contains resin beads which hold electrically charged ions. When hard water passes through the softener, calcium and magnesium ions are attracted to the charged resin beads. The result is removal of calcium and magnesium ions which produces soft water.

This system is controlled with simple, user-friendly electronics displayed on a LCD screen. The main page displays the current time and the remaining gallons in meter mode or the remaining days in calendar clock mode. The system will also scroll through other pertinent information.

Where To Install The Softener

- Place the softener as close as possible to the pressure tank (well system) or water meter (city water).
- Place the softener as close as possible to a floor drain, or other acceptable drain point (laundry tub, sump, standpipe, etc.).
- Connect the softener to the main water supply pipe BEFORE the water heater. **DO NOT RUN HOT WATER THROUGH THE SOFTENER.** Temperature of water passing through the softener must be less than 100 deg. F.
- Outside faucets and irrigation systems should be supplied with hard water prior to the water softener.
- Do not install the softener in a place where it could freeze. **Damage caused by freezing is not covered by the warranty.**
- Put the softener in a place water damage is least likely to occur if a leak develops. The manufacturer will not repair or pay for water damage.
- A 120 volt electric outlet is needed within 6 feet of the softener. The transformer has an attached 6 foot power cable. **Be sure the electric outlet and transformer are in an inside location, to protect from wet weather.**
- If installing in an outside location, you must take the steps necessary to assure the softener, installation plumbing, wiring, etc. are protected from the elements and contamination sources.
- **Keep the softener out of direct sunlight.** The sun's heat may soften and distort plastic parts.

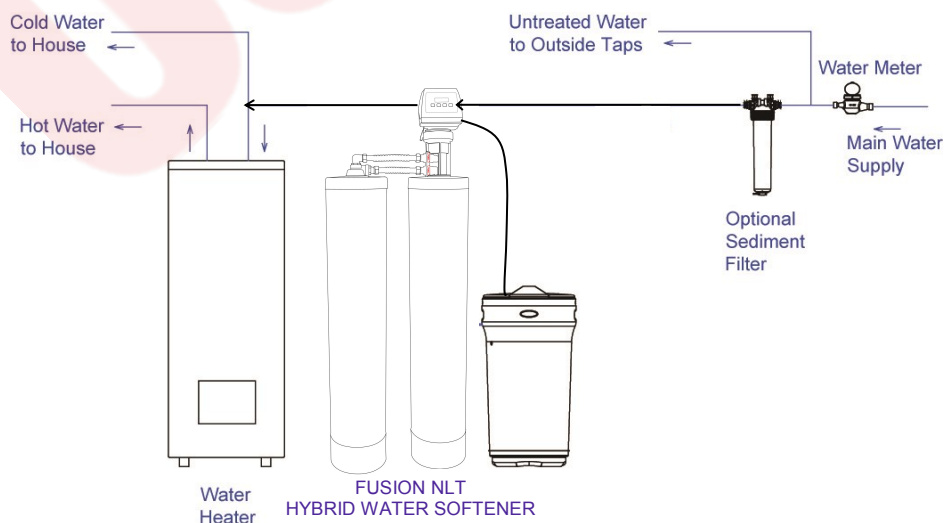

Softener Preparation

Fusion NLT Tank Installation Instructions

WATER PRESSURE: A minimum of 20 pounds of water pressure is required for regeneration valve to operate effectively.

ELECTRICAL FACILITIES: An uninterrupted alternating current (A/C) supply is required. Note: Other voltages are available. Please make sure your voltage supply is compatible with your unit before installation.

EXISTING PLUMBING: Condition of existing plumbing should be free from lime and iron buildup. Piping that is built up heavily with lime and/or iron should be replaced.

LOCATION OF FUSION NLT TANK AND DRAIN: The Infusion tank should be located close to a drain to prevent air breaks and back flow.

CAUTION: Water pressure is not to exceed 80 psi, water temperature is not to exceed 110°F (43°C), and the unit cannot be subjected to freezing conditions.

Media Installation

- 1) Remove the tank from carton.
- 2) Verify the riser tube is centered in the bottom center of the tank. A flashlight may be necessary.

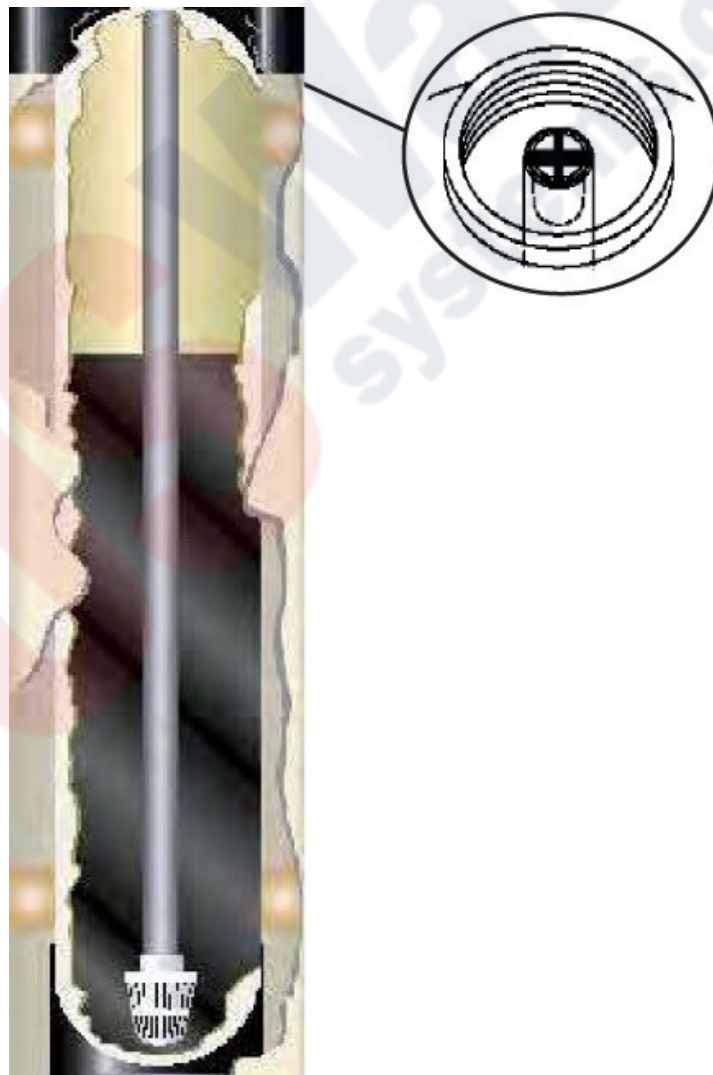

Softener Preparation

3) Place a piece of duct tape over the riser tube of one of the tanks, so no gravel or carbon enters the riser while filling. Both tanks are the same and it does not matter which tank is used for the carbon and which tank is used for the softening resin. Gravel will be poured in the carbon tank ONLY.



4) Use the Blue Funnel provided, to pour the gravel and carbon into the tank. Pour it evenly around the hole to ensure it is well distributed in the tank and pour slow enough, to keep from plugging the hole. The gravel should be poured in the tank first, then pour the carbon in the tank second. Pour all the gravel and carbon that was shipped in the tank. A helper may be needed to hold the funnel during the filling process. It is recommended that a dust mask and safety goggles be worn to prevent possible injury.

5) Once the carbon tank has been loaded with gravel and carbon, remove the duct tape and funnel and fill the tank with water (if possible/practical) and let it soak. This will decrease the rinse time needed to remove the carbon fines/dust during startup. If this cannot be done, the rinse time may take longer but it does not affect the performance or operation. Usually 1-2 hours of soak time is sufficient to reduce the rinse time during startup.

6) Now follow the same procedure for the softener resin tank. There is NO gravel in the softening resin tank. Pour all the resin that was shipped in the softener tank. The softener tank does not use gravel. Once all the softener resin has been poured in the tank, remove the tape and funnel. This tank can be filled with water if possible but is not required. The softening resin usually rinses quickly, but filling the tank with water will reduce the amount of air that must be flushed prior to startup.

Softener Preparation

7) Remove the hybrid tank inter-connect parts and lay them out. The Primary Tank Valve Adaptor, Control Valve Collar and Control Valve Nut may be assembled when they are received. Separate these pieces by loosening and removing the Control Valve Nut and pulling the Control Valve Collar and Primary Tank Valve Adaptor apart.

The following parts should be with the kit;

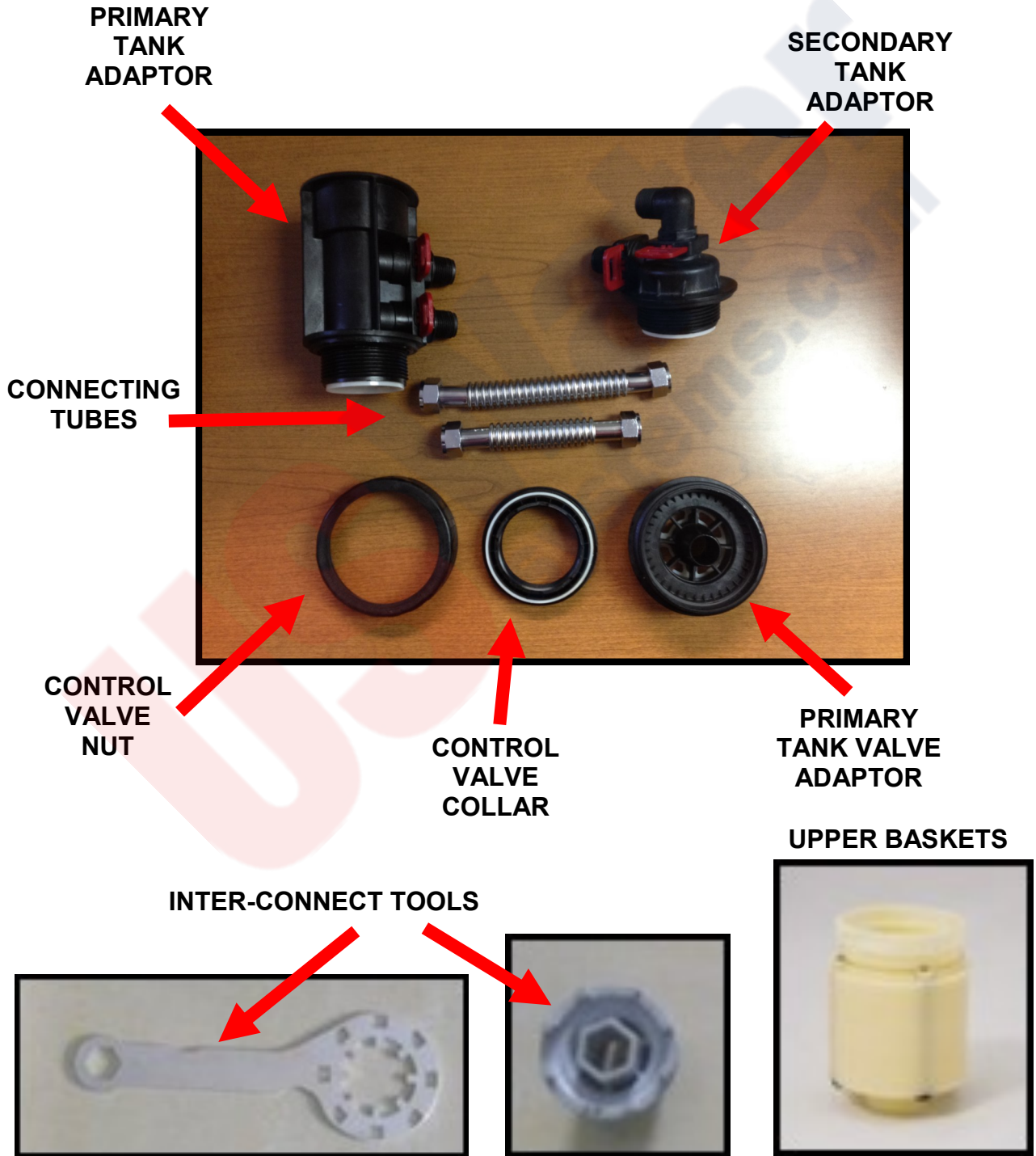

Softener Preparation

- 6) Separate the parts and lay them out like the picture on the previous page.
 7) Lubricate the distributor and tank O-ring on the primary tank adaptor.



- 8) Install an upper basket on the bottom of the primary tank adaptor.



- 9) Slide the primary tank adaptor upper basket over the distributor tube on the **CARBON** tank. Slide it down and tighten it hand tight by turning it clockwise. Snug it with both hands. DO NOT use tools to tighten the adaptor or damage may occur. It doesn't need to be really tight because the O-ring is creating the seal.

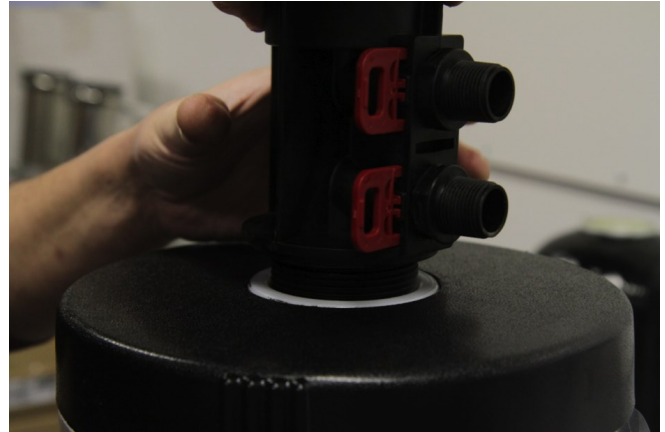
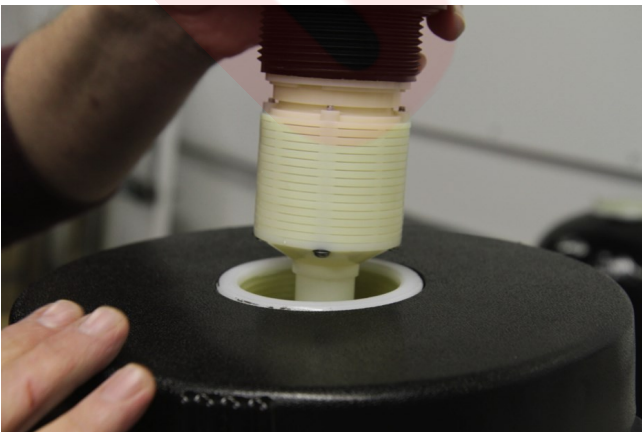

Softener Preparation

- 10) Lubricate the distributor and tank O-ring on the secondary tank adaptor.



- 11) Install the upper basket on the bottom of the secondary tank adaptor by lining up the slots and turning it clockwise to lock the basket into the adaptor. Then slide the secondary tank adaptor on the **SOFTENER RESIN** tank, push it down and tighten it hand tight. Snug it further with your hand. **DO NOT** use tools to tighten the tank adaptor.



- 12) Install the control valve nut on the valve. Now install the control valve collar on the control valve.

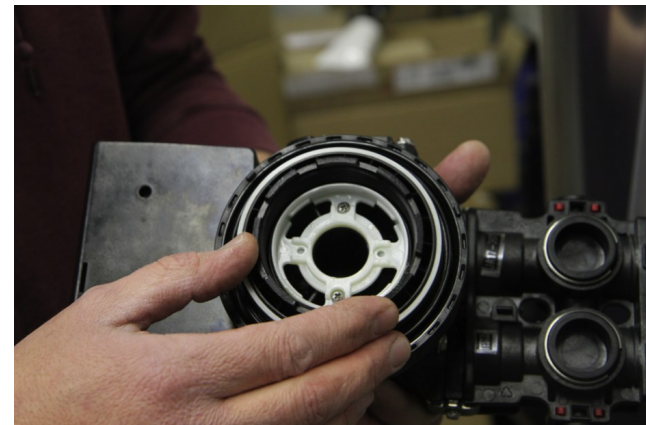
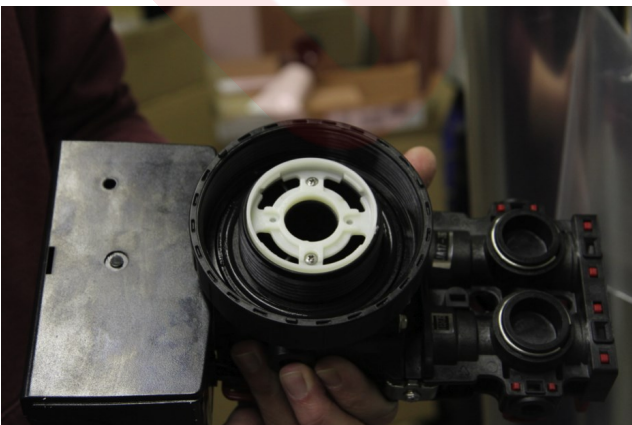

Softener Preparation

13) Use the inter-connect tools to tighten the collar on the valve.

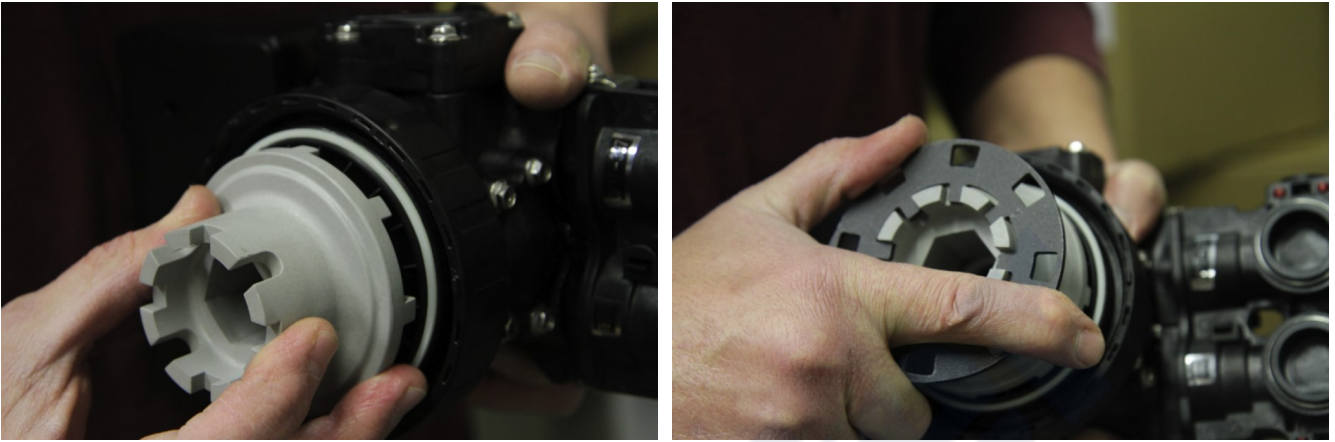

14) Lubricate the distributor and tank O-rings on the primary tank valve adaptor.



15) Install the primary tank valve adaptor on the primary tank adaptor. Use the supplied tool to tighten it in the primary tank adaptor.



16) Lubricate the center O-ring on the control valve collar. Lubricate the inside edge of the primary tank adaptor.

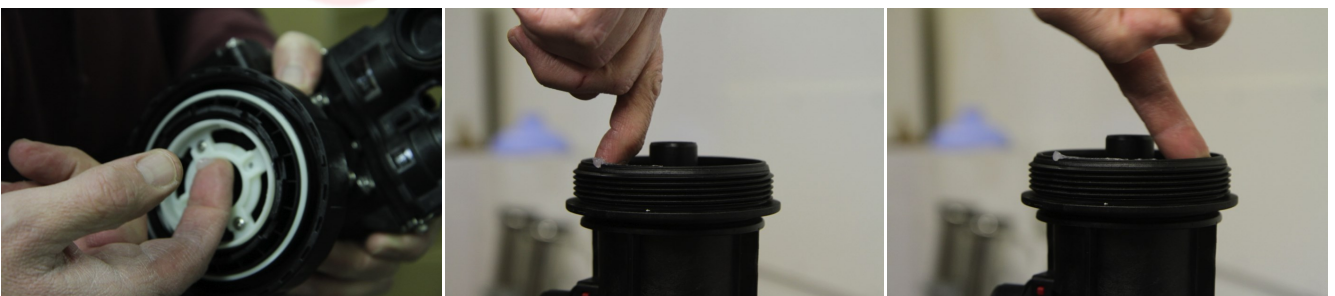

Softener Preparation

- 17) Place the valve on the primary tank adaptor and tighten the collar hand tight. **DO NOT** use tools. Tightening the collar hand tight is sufficient.



- 18) Connect the tanks together using the stainless steel tubes. If the threaded adaptors were previously installed, remove the red clips and pull the adaptors out.
 19) Lubricate the O-rings on all threaded adaptors.

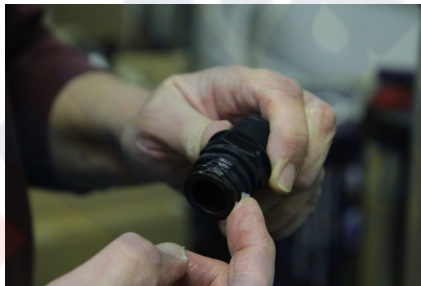

- 20) Install a threaded adaptor in the primary tank adaptor. Install the red clip to secure it. Use channel locks to tight the short stainless steel tube to the treaded adaptor.

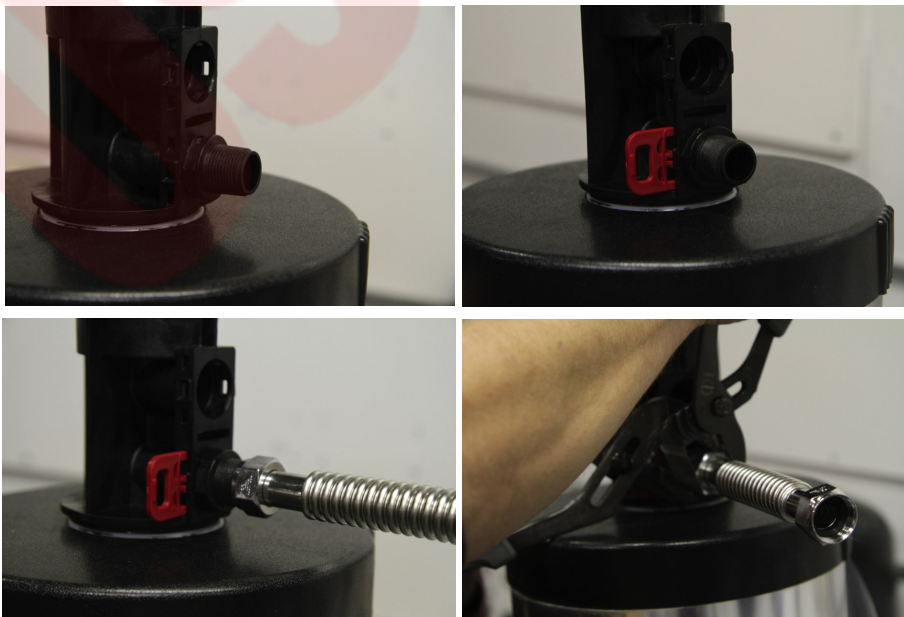

Softener Preparation

- 21) Install a threaded adaptor in the secondary tank adaptor lower port. Install the red clip to secure the threaded adaptor in the secondary tank adaptor. Attach the bottom stainless steel tube from the primary tank adaptor to the secondary tank adaptor. Tighten the tube to the threaded adaptor using channel locks.

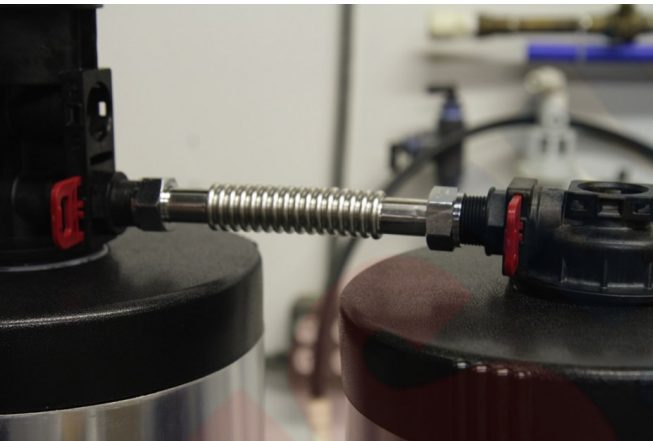

- 22) Install a threaded adaptor in the primary tank adaptor top port. Install the red clip to secure it. Now tighten the long stainless steel tube on the threaded adaptor and tighten it with channel locks.



Softener Preparation

- 23) Install the 90 degree angled threaded adaptor on the other end of the longer stainless steel tube. Place the angled threaded adaptor in the top port on the secondary tank adaptor and secure it with a red clip. Now tighten the longer stainless steel tube on the angled threaded adaptor using channel locks.



Installation Instructions

1. If your hot water tank is electric, turn off the power to it to avoid damage to the element in the tank.
2. If you have a private well, turn the power off to the pump and then shut off the main water shut off valve. If you have municipal water, simply shut off the main valve. Go to the faucet, (preferably on the lowest floor of the house) turn on the cold water until all pressure is relieved and the flow of water stops.
3. Locate the softener tank and brine tank close to a drain where the system will be installed. The surface should be clean and level.
4. Connect the inlet and outlet of the softener using appropriate fittings. Perform all plumbing according to local plumbing codes.
 - **ON COPPER PLUMBING SYSTEMS BE SURE TO INSTALL A GROUNDING WIRE BETWEEN THE INLET AND OUTLET PIPING TO MAINTAIN GROUNDING.**

Any solder joints being soldered near the valve must be done before connecting any piping to the valve. Always leave at least 6" (152 mm) between the control valve and joints being soldered when soldering pipes that are connected to the valve. Failure to do this could cause damage to the valve.

The Fusion NLT is equipped with 1" removable connectors. It is recommended that these connectors are installed in the plumbing fitting using Teflon tape then lubricate the o-ring on the connector remove the red clips and push them into the bypass valve once they are tight in the plumbing fitting. The red clips can then be re-installed to secure the connectors in the bypass valve.

The inlet and outlet can be identified on the bypass valve. There are arrows stamped in the bypass valve showing flow (See page 19 diagram). The arrow pointing toward the valve is the inlet and the arrow pointing away from the valve is the outlet.

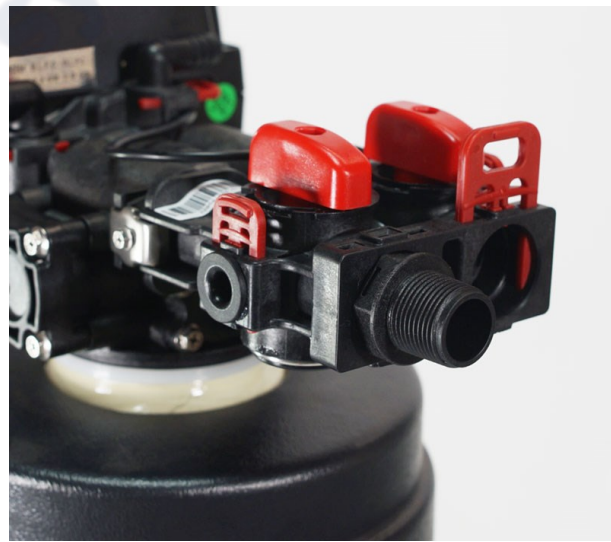

All piping should be secured to prevent stress on the bypass valve and connectors.

Installation Instructions

5. Connect the drain hose to the valve and secure it with a hose clamp. Run the drain hose to the nearest laundry tub or floor drain. This can be ran up overhead or down along the floor. Drain hose should be a minimum of 1/2". If running the drain line more than 20 ft overhead, it is recommended to increase the hose size to 3/4". A DIRECT CONNECTION INTO A WASTE DRAIN IS NOT RECOMMENDED. A PHYSICAL AIR GAP OF AT LEAST 1.5" SHOULD BE USED TO AVOID BACTERIA AND WASTEWATER TRAVELLING BACK THROUGH THE DRAIN LINE INTO THE SOFTENER.

**Hose barb fitting for drain line.
Be sure to use a hose clamp to
secure the line.**

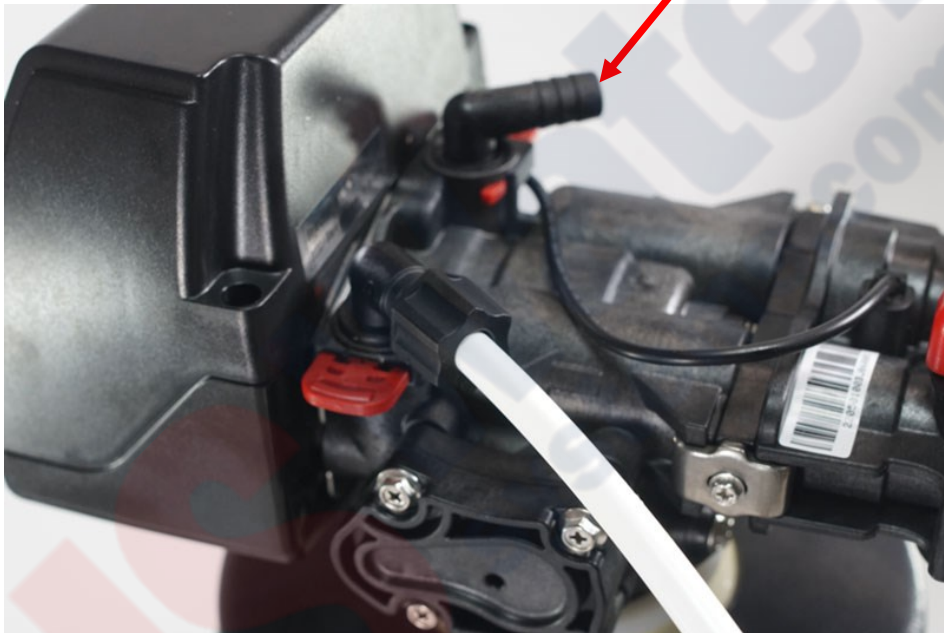

Be sure to secure the drain line. The softener will drain with force and it should be secured to prevent a leak. Hose clamps should be used to secure the drain line at the connection points.

Installation Instructions

6. Connect the brine line to the control valve by removing the nut on the brine elbow on the control valve and sliding it on the brine line. There is a brass tube stiffener pre-installed in the brine line. Make sure this is in the brine line before installing the line in the control valve elbow.



Push the brine line in the elbow fitting on the control valve until it stops. Then push the nut down on the fitting and tighten it hand tight. Use channel locks to tighten the nut an additional 1/2 turn.

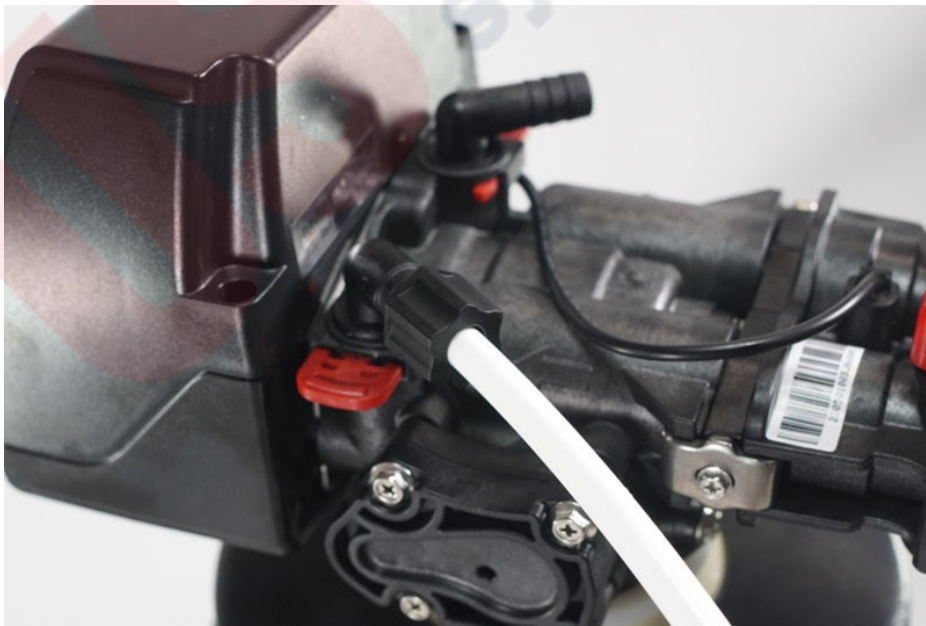

Installation Instructions

Now connect the brine line to the brine tank safety float assembly. Remove the brine tank lid and the brine well cap. Then push the brine line through the brine tank and brine well.



Remove the nut from the brine safety valve elbow. BE CAREFUL not to lose the sleeves in the nut. Slide the nut and sleeves over the brine line.



Installation Instructions

Slide the nut and sleeves over the brine line. Be sure to install the sleeves properly (see pictures below).



Installation Instructions



Installation Instructions

Be sure brass stiffener is in the brine tubing, then push the tubing in the elbow. Now tighten the nut by hand. Be sure not to cross thread it. Now tighten it an additional full turn with pliers or channel locks.



Installation Instructions

7. Using the Allen Key (included), place the unit in the bypass position (See page 19 for bypass valve handle placement). Slowly turn on the main water supply. At the nearest cold treated water tap nearby remove the faucet screen, open the faucet and let water run a few minutes or until the system is free of any air or foreign material resulting from the plumbing work.



8. Make sure there are no leaks in the plumbing system before proceeding. Close the water tap when water runs clean.
9. Open the brine tank lid and add 5 gallons of water to the brine tank. Add a minimum of 80lbs of salt to the brine tank.
10. Proceed to start up instructions.

Note: *The unit is not ready for service until you complete the start-up instructions.*

Installation Overview

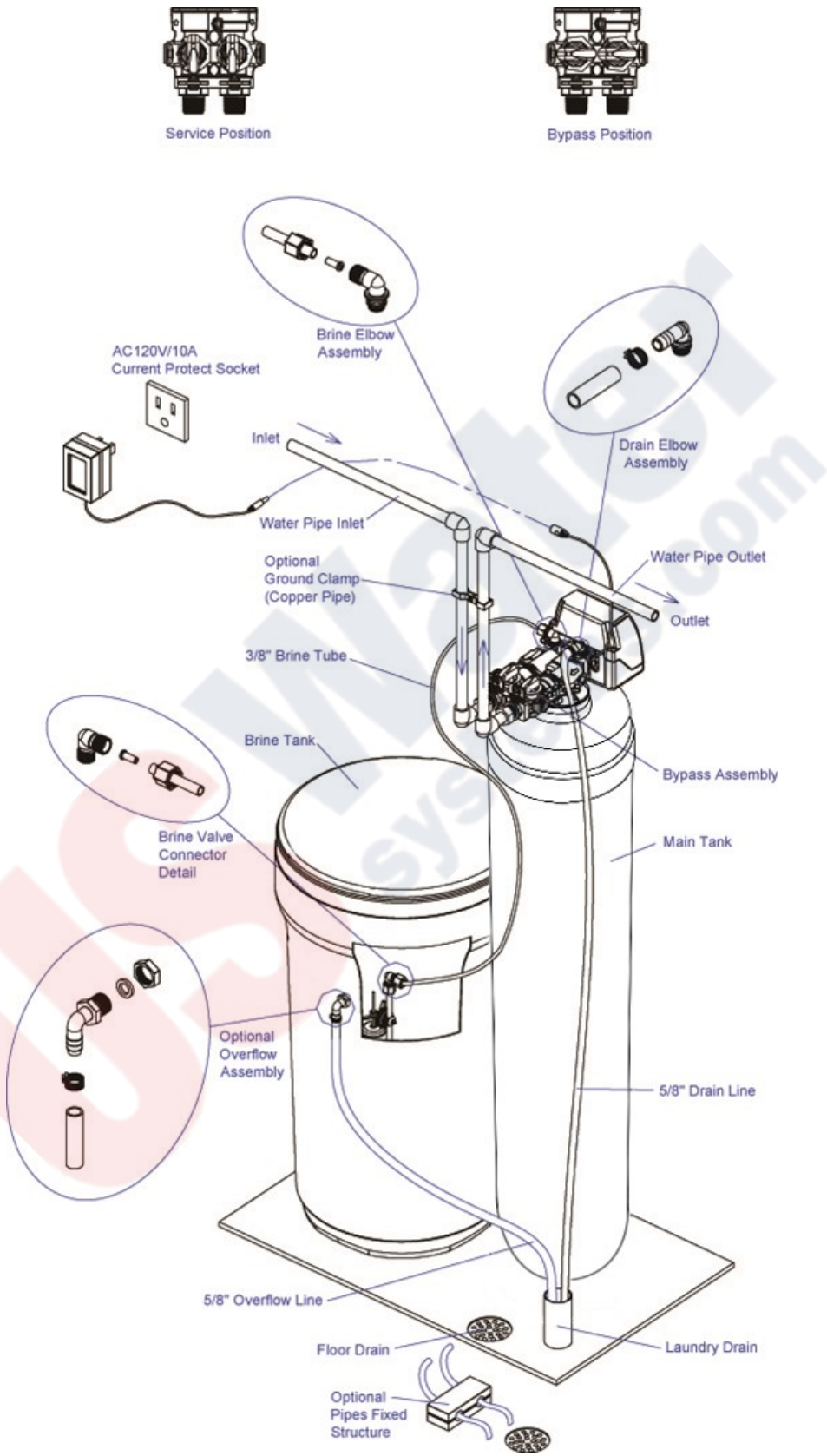

System Start-Up

Key Pad Configuration

SET-TINGS	This function is to enter the basic set up information required at the time of installation.
MANUAL REGEN	This function is to initiate an immediate or delayed manual regeneration.
DOWN / UP	Increase or decrease the value of the settings while in the programming mode.



Manual Regeneration (Step / Cycle Valve)

DELAYED REGENERATION

Press and release the MANUAL REGEN. Button to set a delayed regeneration that will occur at the regeneration time. The main display page will show DELAYED REGEN ON. To cancel press and release the MANUAL REGEN. Button. The main display page will show DELAYED REGEN OFF.

IMMEDIATE REGENERATION

To start an immediate regeneration (or step valve through each position), press and hold the MANUAL REGEN. Button for 3 seconds (until beeps). The valve will start an immediate regeneration. Press any key to skip to the next cycle.

Start-up Instructions

1. Plug the power transformer into an approved power source. Connect the power cord to the valve.
2. When power is supplied to the control, the screen will display service position parameters. If screen is locked, the screen will display "PRESS SETTINGS 3S TO UNLOCK". Follow the instructions and press SETTINGS for 3 seconds to unlock. Press and hold the "Manual" regen button. The valve will display "Advancing to Brine". Once the valve stops moving the valve will display "Brine" and will show a time value that is counting down.
3. Manually step the valve past the BRINE position to the BACKWASH position. Press any key to skip the BRINE cycle and move to the Backwash cycle..
4. Once in the BACKWASH cycle with a time value counting down, open the inlet on the bypass valve slowly and allow water to enter the unit. Allow all air to escape from the unit before turning the bypass fully open.
5. Then allow water to run to drain for 3-4 minutes or until all media fines are washed out of the softener indicated by clear water in the drain hose.
6. When the backwash cycle is complete, the valve will advance to the RINSE position. Continue to let the softener rinse. Check the drain line flow. Allow the water to run for the entire rinse cycle.
7. When the rinse cycle is complete, the valve will advance to the REFILL position. Check that the valve is filling water into the brine tank. Allow the valve to refill for the full amount of time as displayed on the screen to insure a proper brine solution for the next regeneration.
8. The valve will automatically advance to the SERVICE position. Open the outlet valve on the bypass, then open the nearest treated water faucet and allow the water to run until clear, close the tap and replace the faucet screen.
8. Program unit.

Programming Instructions

The factory setting for WATER TYPE is WELL / OTHER. Do not adjust this setting until after start-up is complete. If the setting is changed to MUNICIPAL before start-up, the back wash cycle will be skipped. **The Fusion Hybrid Water Softeners will not be changed.**

Settings

Press SETTINGS key (3 SECONDS / BEEP)

VALVE MODE
SOFTENER UF

TIME OF DAY
12:01 PM

YEAR
2012

MONTH
AUGUST

DAY
21

SET HARDNESS
20 GRAINS

SET PEOPLE
4

SALT SETTING
HIGH EFFICIENCY
STANDARD
IRON & MN

WATER TYPE
MUNICIPAL
WELL / OTHER

REGEN TIME
2:00 AM

PROGRAMMING
COMPLETE

CHANGE SETTINGS

To change settings press the SETTINGS key for 3 seconds. The first screen to be displayed will be the TIME OF DAY. To adjust the HOUR values, use the UP or DOWN key. To advance to the MINUTE values, press the SETTINGS key again. After adjusting each value using the UP or DOWN keys, continue advancing to the next value or screen by pressing the SETTINGS key.

TIME OF DAY, YEAR, MONTH, DAY

Time of day is for normal operation of system and the scheduling of the regeneration time. The date is used in a diagnostic function to track the last time the system regenerated.

SET HARDNESS

This value is the maximum compensated water hardness in grains per gallon of the raw water supply. It is used to calculate the system capacity. If Ferrous Iron is present add 4 gpg for every 1 ppm of Ferrous Iron.

SET PEOPLE

This value is the number of people living in the home. It is used to calculate the amount of water needed for daily use and the reserve capacity of the system.

SALT SETTING

Choose HIGH EFFICIENCY to minimize salt usage. Your system will regenerate a little more often but your salt usage can be reduced by 20% compared to the STANDARD setting.

IF YOU CHOOSE HIGH EFFICIENCY PLEASE CHANGE THE CYCLE TIMES USING THE PROGRAMMING TABLE ON PAGE #42.

Choose STANDARD (FACTORY SETTING) when you need to maximize your capacity but still operate the system with good efficiency. **THIS IS THE FACTORY SETTING. CYCLES TIMES FOR STANDARD ARE FACTORY SET.**

Choose IRON & MN if you have problem water containing these minerals. The high salt setting will be needed since these minerals are more difficult to clean out of the resin bed. Note: A resin cleaner will also need to periodically added to the brine tank to insure proper operation.

IF YOU CHOOSE IRON & MN PLEASE CHANGE THE TIMES USING THE TABLE ON PAGE #42.

WATER TYPE

This setting will determine if the BACKWASH OVERRIDE function will be on or off. Select WELL / OTHER if any Iron or Manganese is present or if the water source is not clean (< 1NUT turbidity). The system will back wash every time. WELL/OTHER must be selected on all Fusion Hybrid Water Softeners.

REGEN TIME

This setting determines the time of day to perform a scheduled regeneration.

About The System

Operation During A Power Failure

In the event of a power failure, the valve will keep track of the time and day for **48 hours**. The programmed settings are stored in a non-volatile memory and will not be lost during a power failure. If power fails while the unit is in regeneration, the valve will finish regeneration from the point it is at once power is restored. If the valve misses a scheduled regeneration due to a power failure, it will queue a regeneration at the next regeneration time once power is restored.

Safety Float

The brine tank is equipped with a safety float which prevents your brine tank from overflowing as a result of a malfunction such as a power failure.

Main Display

The main display will pause on the Date and Time page for 5 seconds. Then it will continually scroll through all of the system diagnostic display pages. To manually scroll through the diagnostics, press the down or up key. To reset the TOTAL REGENS, TOTAL GALLONS OVER RUN TOTAL, or PEAK flow rates, press and hold the MANUAL REGEN key until the value changes to zero.

Diagnostic Display

PARAMETER	DESCRIPTION
JULY/17/2012 8:30 PM	Month, Day, Year, Time
TOTAL 1,500 GAL REMAIN 1,200 GAL	The total amount is the system capacity when fully regenerated. The remaining is the capacity left in the system.
PEOPLE 2 RESERVE 150 GAL	Number of people in the household and the calculated reserve capacity. When remaining reaches reserve capacity a regeneration will be scheduled.
EST. DAYS TO NEXT REGEN 06 DAYS	The estimated number of days until the next regeneration will occur.
LAST REGEN 9/24/12	The date of the last regeneration.
TOTAL REGENS 10	The total number of regenerations.
TOTAL GALLONS 001590 GAL	The total amount of gallons treated by the system.
OVER RUN TOTAL 0500 GAL	The total amount of water that has exceeded the system capacity over the last 4 regenerations. When remaining goes to zero, the gallons used will be added to over run total.
CURRENT 1.5 GPM PEAK 6.5 GPM	The current flow rate and the peak flow rate since the last regeneration.
DELAYED REGEN OFF	Advises whether a delayed regeneration has been scheduled manually or automatically.
REGEN TIME 2:00 AM	The current setting for regeneration time.
REFILL TIME 3:00 MIN	The current calculated refill time. (Note: The refill time shown will be reduced by the pre-fill %. i.e. If pre-fill % is 70%, then displayed refill time will be 70% of the full target.)
VALVE MODE SOFTENER UF	The current setting of the valve mode.
TOTAL 4 DAYS REMAIN 3 DAYS	The number of days remaining before regeneration. This option is only in filter mode.

New Sounds

You may notice new sounds as your water softener operates. The regeneration cycle lasts up to 180 minutes. During this time, you may hear water running intermittently to the drain.

Precision Brining Regeneration Process

When the system capacity is near exhausted, a regeneration is necessary to restore the system to full capacity. The table below explains the regeneration steps.

Step	Name	Description
#1	Brine Making	A precise calculated amount of fresh water is added to the brine tank to make enough brine to regenerate only the exhausted portion of the ion exchange resin. Note: 70% of the required fresh water is added in Step #5 in the previous regeneration. The default brine making time is 30 minutes.
#2	Brine	The brine solution is introduced slowly to the bottom of the tank flowing up through the ion exchange resin pushing the hardness out to drain and restoring system capacity.
#3	Back Wash	Fresh water is introduced to the bottom of the tank flowing upwards expanding the ion exchange resin to rinse out any dirt or small particles to the drain and to un-compact the bed to restore full service flow rates.
#4	Rinse	Fresh water is introduced from the top of the tank down flowing down through the ion exchange resin rinsing any excess brine solution out to the drain.
#5	Refill	A fixed amount of soft water is added to the salt tank to prepare and insure fully saturated brine for the next regeneration. Note: Step #1 will "top off" the amount of water needed based on the percentage of exhausted resin to be regenerated.

Automatic Hard Water Bypass During Regeneration

The regeneration cycle can last 30 to 180 minutes, after which soft water service will be restored. During regeneration, hard water is automatically bypassed for use in the household. Hot water should be used as little as possible during this time to prevent hard water from filling the water heater. This is why automatic regeneration is set for sometime during the night and manual regenerations should be performed when little or no water will be used in the household. Normal regeneration time is 2:00 AM.

System Configuration

FUSION NLT UPFLOW System Configuration			
Tank Size (Diameter)	Injector Set	Brine Line Flow Control (BLFC)	Drain Line Flow Control (DLFC)
8"	#0000 Black	0.20 GPM	#1 (1.5 GPM)
9"			#2 (2.0 GPM)
10"	#3 (2.4 GPM)		
12"	#00 Purple		#5 (3.5 GPM)
13"	#0 Red		#6 (4.0 GPM)

Manual Bypass

In the case of emergency, such as an overflowing brine tank, you can isolate your water softener from the water supply using the bypass valve located at the back of the control. In normal operation the bypass is open with the on/off knobs in line with the inlet and outlet pipes.

To isolate the softener, simply rotate the knobs clockwise (as indicated by the word BY-PASS and arrow) until they lock. You can use your water related fixtures and appliances as the water supply is bypassing the softener. However, the water you use will be hard. To resume soft water service, open bypass valve by rotating the knobs counterclockwise.

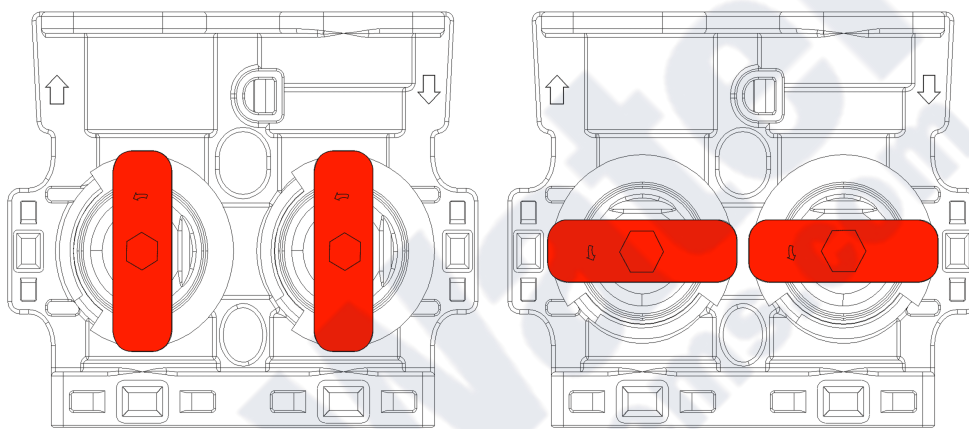

SERVICE POSITION

BYPASS POSITION

Maintenance

Adding Salt

Use only Extra Course Grade or Crystal water softener salt. Check the salt level monthly. It is important to maintain the salt level above the water level. To add salt, simply lift the salt lid and add the salt directly into the brine tank. Be sure the brine well cover is on and fill only to the height of the brine well.

Salt Bridging

Humidity or wrong type of salt may create a cavity between the water and the salt. This action, known as “bridging”, prevents the brine solution from being made, leading to your water supply being hard.

If you suspect salt bridging, carefully pound on the outside of the brine tank or pour some warm water over the salt to break up the bridge. This should always be followed up by allowing the unit to use up any remaining salt and then thoroughly cleaning out the brine tank. Allow two hours to produce a brine solution, then manually regenerate the softener.

Cleaning or Replacing Injectors

Sediment, salt and silt will restrict or clog the injector. A clean water supply and pure salt will prevent this from happening.

The injector assembly is located on the right side of the control valve. This assembly is easy to clean.

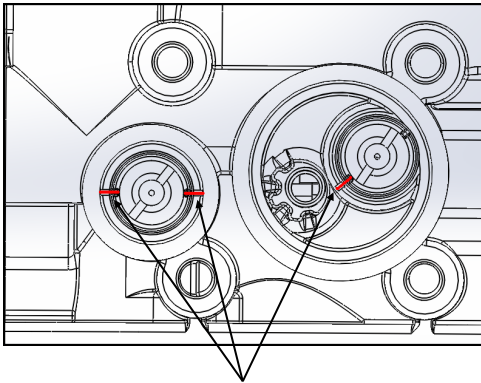

TIP: There are marks on the injector holder that must be lined up to the marks on the valve to fully insert the holder into the hole in the valve body

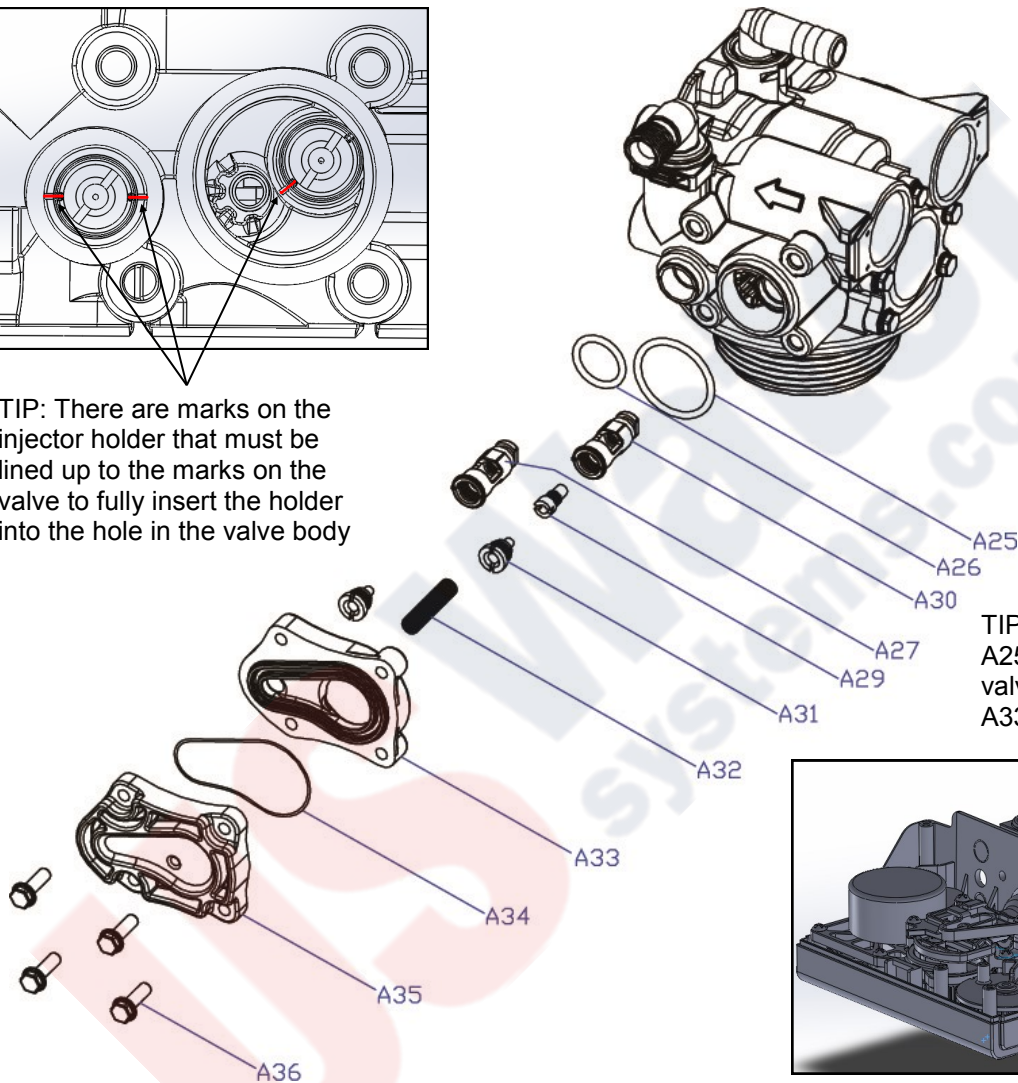

TIP: Place the o-rings A25 and A26 onto the valve before installing A33.

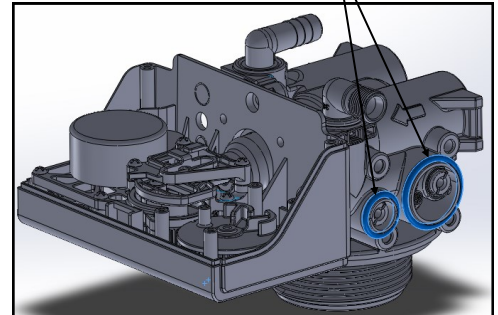

1. Shut off the water supply to your softener and reduce the pressure by opening a cold soft water faucet.
2. Using a screwdriver, remove the four screws holding the injector cover to the control valve body.
3. Carefully remove the assembly and disassemble as shown in above figure.
4. The injector orifice is removed from the valve body by carefully turning it out with a large screwdriver. Remove the injector throat the same way.
5. Carefully flush all parts including the screen. Use a mild acid such as vinegar or Pro-Rust Out to clean the small holes in the orifice and throat.
6. Reassemble using the reverse procedure.

Replacing Brine Line Flow Control (BLFC, COMPLETED BEFORE PURCHASE)

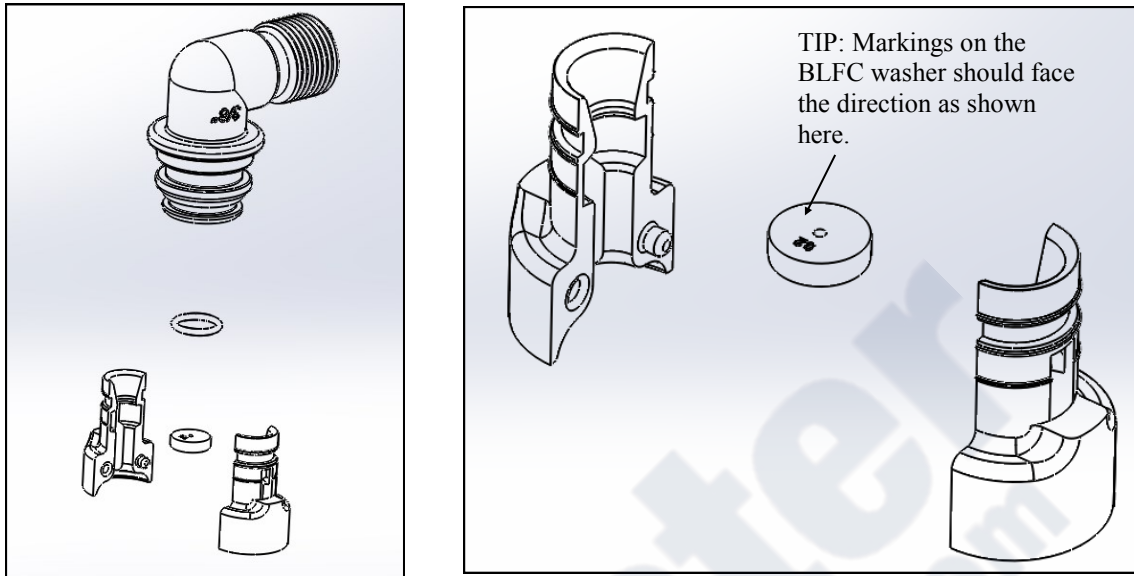

1. Remove the red clip that secures the brine elbow.
2. Remove the BLFC holder from the elbow fitting.
3. Split the BLFC holder apart and remove the flow washer.
4. Reassemble using the reverse procedure.

Replacing Drain Line Flow Control (DLFC, COMPLETED BEFORE PURCHASE)

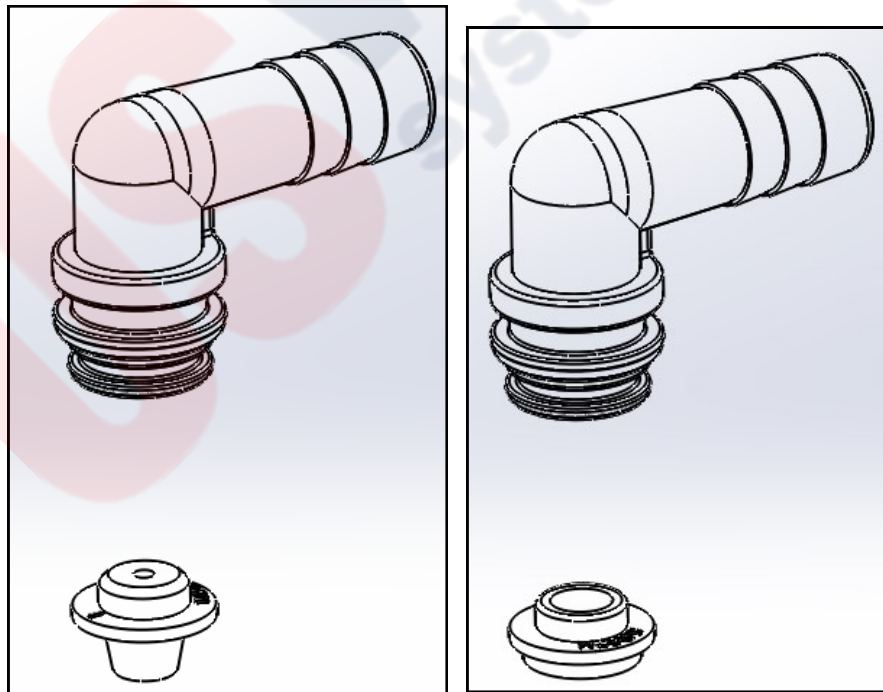

1. Remove the red clip that secures the drain line elbow.
2. Remove the BLFC washer from the elbow fitting.
3. Reassemble using the reverse procedure.

Care of Your System

To retain the attractive appearance of your new water softener, clean occasionally with mild soap solution. Do not use abrasive cleaners, ammonia or solvents. Never subject your softener to freezing or to temperatures above 100°F.

Resin Cleaner

An approved resin cleaner must be used on a regular basis if your water supply contains iron. The amount of resin cleaner and frequency of use is determined by the quantity of iron in your water (follow the directions on the resin cleaner package).

Item #	Description
710-RK41N	Res Care—1 Gal. Bottle
710-RK32N	Res Care—1 qt. Bottle



Item #	Description
710-RO12N	Rust Out—1.5 lb. Bottle
710-RO65N-CS	Rust Out—5 lb. Bottle Case
710-RO50N	Rust Out—50 lb. Pail



Item #	Description
710-RK11K	Easy Feeder—1.0 oz/day Feeder



Sanitizing Procedure

Care is taken at the factory to keep your water softener clean and sanitary. Materials used to make the softener will not infect or contaminate your water supply, and will not cause bacteria to form or grow. However, during shipping, storage, installing and operating, bacteria could get into the softener. For this reason, sanitizing as follows is suggested when installing.

Sani-System Liquid Sanitizer Concentrate



Item# 710-SS-24WS—Softener Sanitizer 0.25 fl.oz (24 Pack)

1. Be sure to complete all installation steps, including programming.
2. For effective and complete sanitization, Sani-System Liquid Sanitizer Concentrate is recommended. Pour one 0.25 fl. Oz. package into the brine well located in the cabinet or brine tank. (Alternative use 3/4 oz of common 5.25% household bleach)
3. Start an immediate regeneration. (See page 11)
4. The Softener Sanitizer Solution is drawn into and through the water softener to sanitize it. This sanitizing regeneration is over in about two hours. Then, **soft water** is available for your use.

NOTE: Sanitizing is recommended by the Water Quality Association for disinfecting. On some water supplies, they suggest periodic sanitizing.

Main Repair Parts

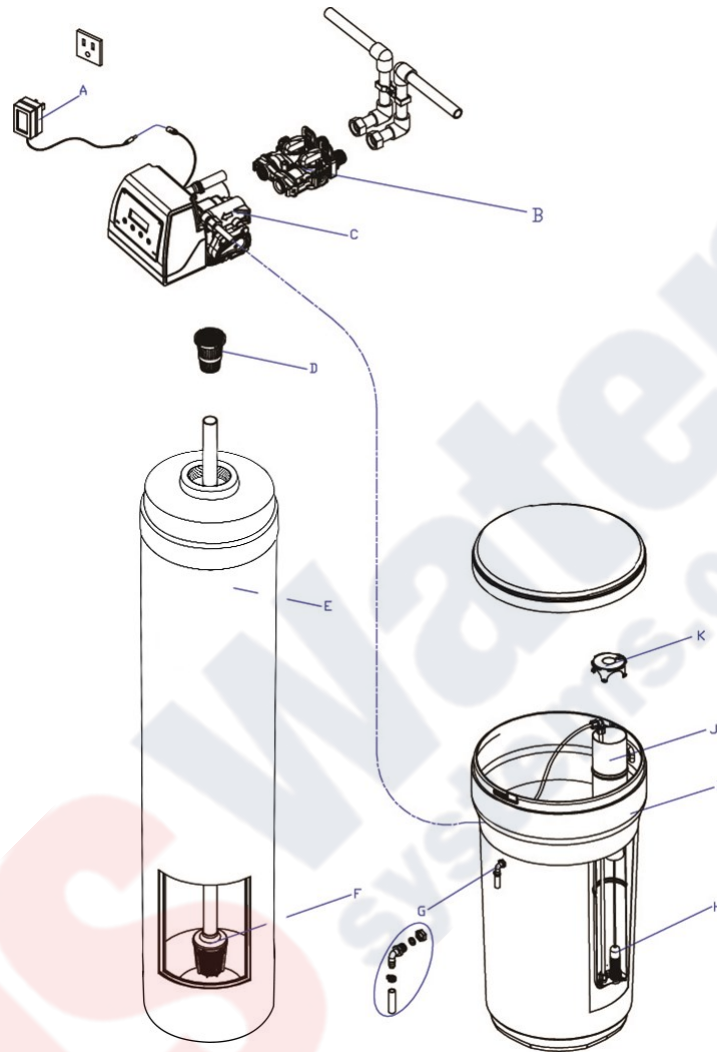

REPLACEMENT PARTS - TWIN TANK

Replacement Part Number	Part Description	DWG #	Quantity
60010052	POWER TRANSFORMER 120V-12V	A	1
60010002	BYPASS / METER	B	1
10010060	FUSION NLT VALVE	C	1
60010048	TOP CONE	D	1
25020041	844 TANK (75)	E	1
25020042	948 TANK (100)	E	1
25020043	1054 TANK (150)	E	1
25010058	1252 TANK (200)	E	1
25030007	1465 TANK (300)	E	1
50010005	DISTRIBUTOR 1X54	F	1
60010005	OVER FLOW FITTING ASSEMBLY	G	1
55010023	SAFETY / AIR CHECK ASSEMBLY	H	1
30020006	BRINE TANK BTR-100 (75,100,150)	I	1
30020011	BRINE TANK BTR-145 (200)	I	1
30020032	BRINE TANK BTR-200 (300)	I	1
55010010	BRINE WELL & CAP	J&K	1

Main Repair Parts - Connectors



A

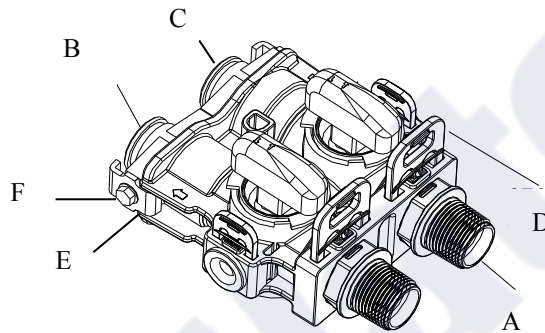

REPLACEMENT PARTS - CONNECTORS

Replacement Part Number	Part Description	DWG #	Quantity
60010019	1" NPT STRAIGHT	A	2
60010079	VALVE COUPLING INLET	B	1
60010101	VALVE COUPLING OUTLET (METER SIDE)	C	1
60010025	PLASTIC SECURE CLIP	D	2
60010046	BYPASS SS CLIP	E	2
60010047	BYPASS SS SCREW	F	2

Control Valve Exploded View

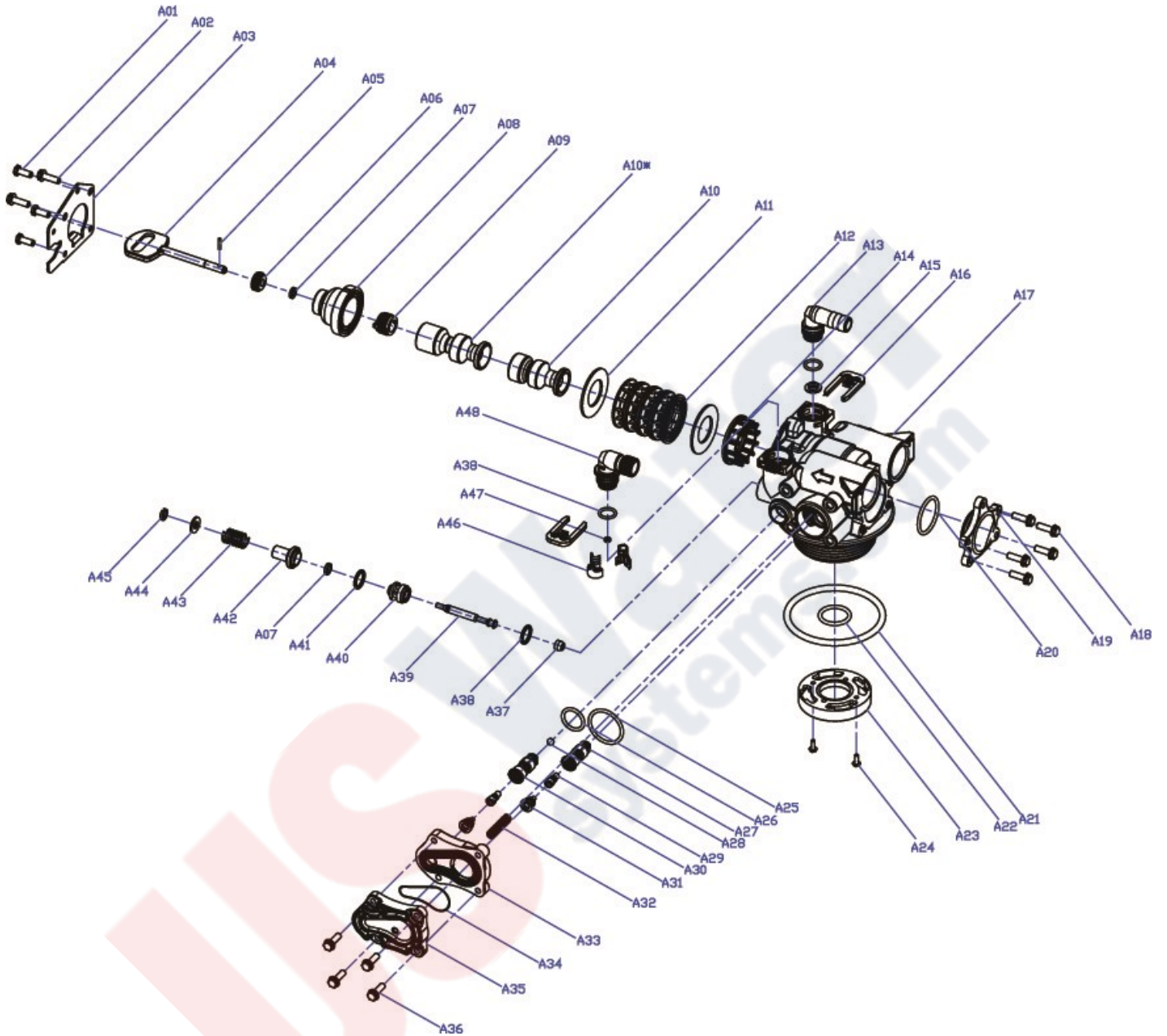

VALVE REPAIR PARTS LIST

Replacement Part Number	Part Description	Replacement Part Number	Part Description
60010127	INJECTOR SET #0000 BLACK	60010129	UPFLOW PISTON ASSEMBLY
60010126	INJECTOR SET #000 GREY	60010171	DOWNFLOW PISTON ASSEMBLY
60010035	INJECTOR SET #00 VIOLET	60010130	SEAL & SPACER KIT
60010034	INJECTOR SET #0 RED	60010131	DLFC #1 1.5 GPM
60010033	INJECTOR SET #1 WHITE	60010132	DLFC #2 2.0 GPM
60010032	INJECTOR SET #2 BLUE	60010133	DLFC #3 2.4 GPM
60010031	INJECTOR SET #3 YELLOW	60010135	DLFC #5 3.5 GPM
60010128	BLFC 0.2 GPM	60010136	DLFC #A 5.0 GPM
60010110	BLFC 0.3 GPM	60010137	DLFC #B 7.0 GPM
60010082	BLFC 0.7 GPM	60010138	DLFC #C 10.0 GPM

Control Valve Parts List

FUSION NLT UPFLOW CONTROL VALVE				
Replacement Part Number	MFG Part Number	Part Description	DWG #	Quantity
	5056087	Screw-M5x12(Hexagon)	A01	3
	5056088	Screw-M5x16(Hexagon With Washer)	A02	2
	5056047	End Plug Retainer	A03	1
	5031016	Fusion NLT Piston Rod	A04	1
	5056097	Piston Pin	A05	1
	5031015	Fusion NLT Quad Ring Plug Cover	A06	1
	5056070	Quad Ring	A07	2
	5031011	Fusion NLT End Plug	A08	1
	5031014	Fusion NLT Piston Retainer	A09	1
	5057002	Fusion NLT Piston(Electrical Upflow)	A10*	1
	5056073	Seal	A11	5
	5056021	Spacer	A12	4
	5010082	Drain Fitting-B	A13	1
	5031005	Fusion NLT Spacer	A14	1
	5056186	DLFC-2#	A15	1
	5056172	Secure Clip-s	A16	2
	5031002	Fusion NLT Valve Body	A17	1
	5056508	Screw-M5x12(Hexagon With Washer)	A18	5
	5030004	Fusion NLT End Cover	A19	1
	5030013	O-Ring- ϕ 30x2.65	A20	1
	5056063	O-Ring- ϕ 78.74x5.33	A21	1
	26010103	O-Ring- ϕ 25x3.55	A22	1
	7060007	Valve Bottom Connector	A23	1
	13000426	Screw-ST2.9X13(Large Washer)	A24	2
	5031022	O-Ring- ϕ 32x3	A25	1
	5031021	O-Ring- ϕ 18x3	A26	1
	5031013	Injector Plug Body	A27	1
	30040089	Injector Throat	A29	2
	5031012	Fusion NLT Injector Fixed Sleeve	A30	1
	30040090	Injector Nozzle	A31	2
	5056103	Injector Screen	A32	1
	5031003	Fusion NLT Injector Cover Body	A33	1
	5031018	O-Ring- ϕ 40x2.65	A34	1
	5031004	Fusion NLT Injector Cover Cap	A35	1
	5031027	Screw-M5x25(Hexagon With Washer)	A36	4
	5056075	Seal Mat	A37	1
	5056134	O-Ring- ϕ 12x2	A38	3
	5056054	Injector Stem	A39	1
	5056031	Injector Spacer	A40	1
	5056081	O-Ring- ϕ 12.5x1.8	A41	1
	5056030	Injector Cap	A42	1
	5056093	Injector Screen	A43	1
	5010049	Special Washer	A44	1
	5056105	Retaining Ring	A45	1
	5031010	Fusion NLT BLFC Fixed Sleeve	A46	2
	5056076	BLFC-2#	A47	1
	5005629	Injector Fitting(3/8".Elbow)	A48	1

Power Head Exploded View

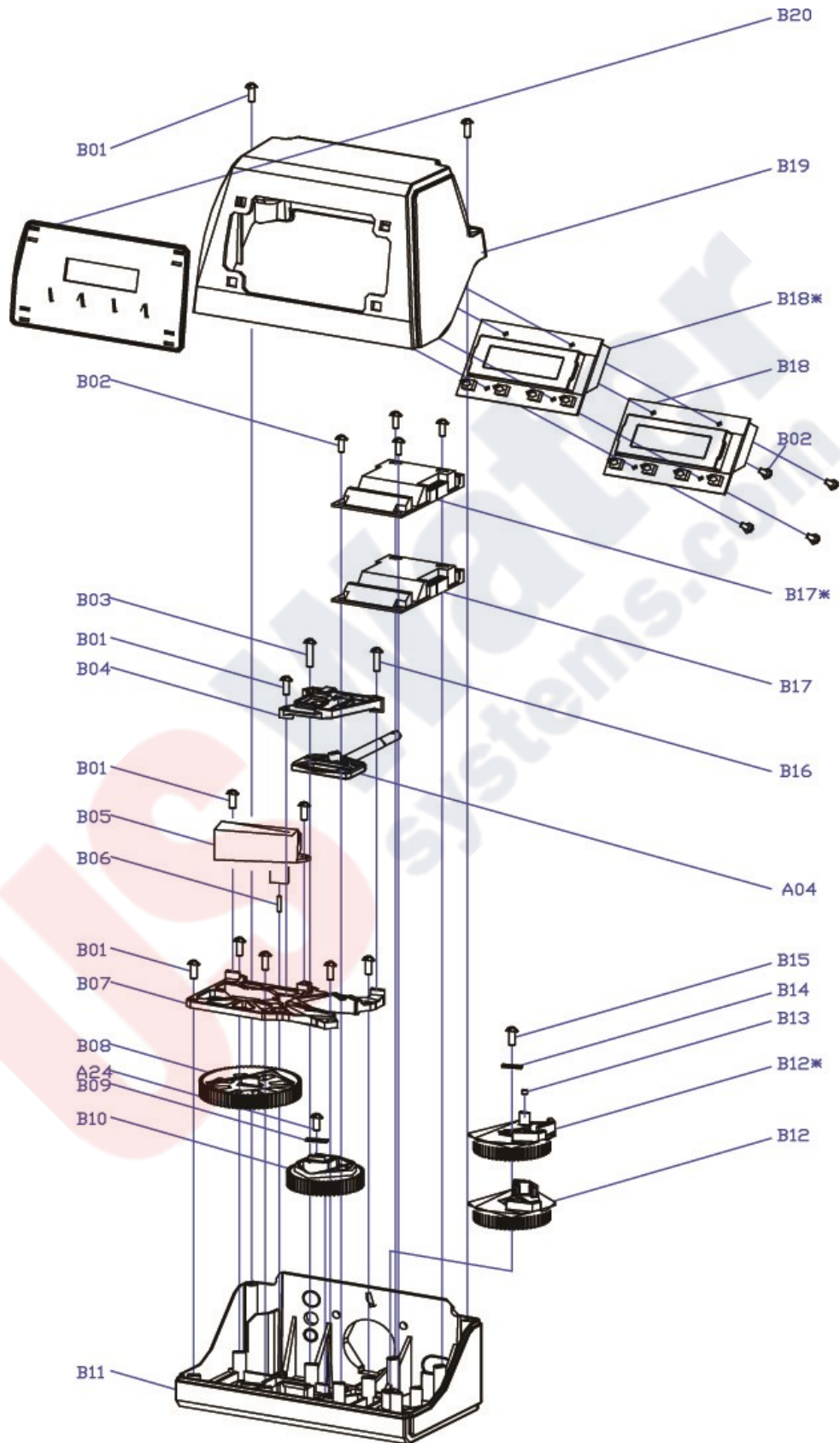

Power Head Parts List

FUSION NLT POWER HEAD (UPFLOW)				
Replacement Part Number	MFG Part Number	Part Description	DWG #	Quantity
	5056084	Screw-ST3.5X13	B01	10
	5010037	Screw-ST2.9X10	B02	9
	13000416	Screw-ST3.5X25	B03	1
	5031007	Piston Rod Guide Plate	B04	1
	5056510	Motor-12v/2rpm	B05	1
	5030014	Motor Power Cable		1
	11700005	Wire Connector		2
	5056098	Motor Pin	B06	1
	5031006	Mounting Plate	B07	1
	5030009	Drive Gear	B08	1
	13000426	Screw-ST2.9X13(Large Washer)	A24	2
	5056139	Washer-3x13	B09	1
	5030007	Main Gear	B10	1
	5030005	Mounting	B11	1
	5031009	Brine Gear(Upflow)	B12*	1
	5010023	Magnet(3x2.7)	B13	1
	5056141	Washer-4x12	B14	1
	5056166	Screw-ST4.2X12(Large Washer)	B15	1
	5031016	Fusion NLT Piston Rod	A04	1
	5010036	Screw-ST3.5X16	B16	1
	5031025	Fusion NLT Main Pcb(Upflow)	B17*	1
	5010031	Meter Assembly		1
	5010046	Meter Strain Relief		1
	5010029	Power Cable		1
	5010035	Power Strain Relief		1
	19010105	Wire Rope-3x100		2
	5031023	Fusion NLT PCB (Upflow)	B18*	1
	5030021	Fusion Wiring Harness		1
	5030032	Fusion Cover(Novo)	B19	1
	5030033	Fusion Display Plate(Novo)	B20	1

Trouble Shooting

Issue	Possible Cause	Possible Solution
A. Unit fails to initiate a regeneration cycle.	1. No power supply.	Check electrical service, fuse, etc.
	2. Defective circuit board.	Replace faulty parts.
	3. Power failure.	Reset time of day.
	4. Defective meter.	Replace turbine meter.
B. Water is hard.	1. By-pass valve open.	Close by-pass valve.
	2. Out of salt or salt level below water level.	Add salt to tank.
	3. Plugged injector / screen.	Clean parts.
	4. Flow of water blocked to brine tank.	Check brine tank refill rate.
	5. Hard water in hot water tank.	Repeat flushing of hot water tank required.
	6. Leak between valve and central tube.	Check if central tube is cracked or o-ring is damaged. Replace faulty parts.
	7. Internal valve leak.	Replace valve seals, spacer, and piston assembly.
	8. Reserve capacity setting too low.	Increase reserve capacity.
	9. Not enough capacity.	Increase salt dosage.
C. Salt use is high.	1. Refill time is too high.	Check refill time setting.
	2. Defective flow control.	Replace.
D. Low water pressure.	1. Iron or scale build up in line feeding unit.	Clean pipes.
	2. Iron build up inside valve or tank.	Clean control and add resin cleaner to clean bed. Increase regeneration frequency.
	3. Inlet of control plugged due to foreign material.	Remove piston and clean control valve.
	4. Deteriorated resin. (Maybe caused from high chlorine or chloramines.)	Re-bed unit. Consider adding carbon pre-treatment.
E. Resin in drain line.	1. Air in water system.	Check well system for proper air eliminator control.
	2. Incorrect drain line flow control (DLFC) button.	Check for proper flow rate.
F. Too much water in brine tank.	1. Plugged injector or screen.	Clean parts.
	2. Valve not regenerating.	Replace circuit board, motor, or control.
	3. Foreign material in brine valve.	Clean parts.
	4. Unit not drawing brine.	Check for vacuum leak in brine line connections.
G. Unit fails to draw brine.	1. Drain line flow control is plugged.	Clean parts.
	2. Injector or screen is plugged.	Clean parts.
	3. Inlet pressure too low.	Increase pressure to 25 PSI.
	4. Internal valve leak.	Replace seals, spacers, and piston assembly.
	5. Safety valve closed.	Check for leak in brine line connections. Replace safety float assembly.
	6. Vacuum leak in brine line.	Check for leak in brine line connections. Tighten all connections.
	7. Drain line has kink in it or is blocked.	Check drain line.
H. Valve continuously cycles.	1. Defective position sensor PCB.	Replace faulty parts.
I. Flow to drain continuously.	1. Valve settings incorrect.	Check valve settings.
	2. Foreign material in control valve.	Clean control.
	3. Internal leak.	Replace seals, spacers, and piston assembly.
	4. Piston is stuck in position. Motor may have failed or gears have jammed or disengaged.	Check for power to motor. Check for loose wire. Check for jammed gears or gears disengaged. Replace faulty parts.
J. Valve makes beeping sound.	1. The piston has not advanced to the next cycle position properly.	Check for power to motor. Check for loose wire. Check for jammed gears or gears disengaged.

Fusion NLT Hybrid Programming				
Part #	087-FNLT-100	087-FNLT-150	087-FNLT-200	087-FNLT-250
Tank Sizes	9 X 48	10 X 54	12 X 52	13 X 54
Cu/Ft	1	1.5	2	2.5
Backwash Flow Control	5	5	7	11
Brine Flow Control	Black	Black	Purple	Red
MASTER PROGRAMMING (PUSH SETTINGS AND MANUAL BUTTONS AT THE SAME TIME FOR 3-5 SECONDS, USE THE MANUAL BUTTON TO MOVE TO EACH PARAMETER)				
Language	ENGLISH	ENGLISH	ENGLISH	ENGLISH
Units	GALLONS	GALLONS	GALLONS	GALLONS
High Efficiency LBS.	3	3	3	3
High Efficiency Grains	5000	5000	5000	5000
STD Capacity LBS.	6	6	6	6
STD Capacity Grains	4100	4100	4100	4100
Iron & MN LBS.	12	12	12	12
Iron & MN Grains	2500	2500	2500	2500
Refill	0.2	0.2	0.2	0.2
Brine Make Time	30	30	30	30
Brine Per Refill	70	70	70	70
Daily Reserve	75	75	75	75
BW Override	2	2	2	2
Forced Regen	NO	NO	NO	NO
Vacation Mode	NO	NO	NO	NO
LEVEL II PROGRAMMING (PUSH THE UP AND DOWN ARROWS AT THE SAME TIME FOR 3-5 SECONDS, USE THE MANUAL BUTTON TO MOVE TO EACH PARAMETER)				
Valve Mode	SOFTENER UF	SOFTENER UF	SOFTENER UF	SOFTENER UF
Unit Size	1 cu/ft	1.5 cu/ft	2 cu/ft	2.5 cu/ft
High Efficiency Cycle Times				
Backwash	10	10	10	10
Brine Draw	99	128	104	102
Rinse	15	15	15	15
Standard Cycle Times				
Backwash	10	10	10	10
Brine Draw	124	147	119	116
Rinse	15	15	15	15
Iron & MN Cycle Times				
Backwash	10	10	10	10
Brine Draw	132	171	139	135
Rinse	15	15	15	15
PUSH AND HOLD THE SETTINGS BUTTON FOR 3-5 SECONDS, USE THE SETTINGS BUTTON TO MOVE TO EACH PARAMETER				
Time of Day	Customer	Customer	Customer	Customer
Hardness	5 above actual	5 above actual	5 above actual	5 above actual
Number of People	Customer	Customer	Customer	Customer
Salt Setting	Standard	Standard	Standard	Standard
Water Source	Well/Other	Well/Other	Well/Other	Well/Other
Regen. Time	2:00AM	2:00AM	2:00AM	2:00AM



WARRANTY

US Water Systems warrants that your new water conditioner is built of quality material and workmanship. When properly installed and maintained, it will give years of trouble free service.

Ten Year Valve and Electronics Guarantee

US Water Systems will replace any part on the valve or electronics which fails within ten years from date of manufacture, as indicated by the serial number, provided the failure is due to a defect in material or workmanship. The only exception shall be when proof of purchase or installation is provided and then the warranty period shall be from the date thereof.

Life Time Warranty on Resin, Mineral Tanks and Brine Tanks

US Water Systems will provide a replacement resin, mineral tank or brine tank to any original equipment purchaser in possession of the Fusion NLT softener that fails provided that the it is at all times operated in accordance with specifications and not subject to freezing.

General Provisions

US Water Systems assumes no responsibility for consequential damage, labor or expense incurred as a result of a defect or for failure to meet the terms of these guarantees because of circumstances beyond our control. Installation workmanship failure is not covered under warranty. Damage caused by environmental conditions such as, lightening strikes, humidity or heat will not be covered under warranty.

These warranties are in lieu of all other warranties expressed or implied, and we do not authorize any person to assume for us any other obligation on the sale of this water conditioner. No responsibility is assumed for delays or failure to meet these warranties caused by strike, government regulations or other circumstances beyond the control of *US WATER SYSTEMS, INC.*

TO OBTAIN WARRANTY SERVICE, CALL OR WRITE: *US WATER SYSTEMS, INC. 1209 COUNTRY CLUB ROAD INDIANAPOLIS, IN 46234 (317) 271-8600.* ANY IMPLIED WARRANTIES OF FITNESS OR MERCHANTABILITY ARE LIMITED TO THE TERMS OF THIS EXPRESSED WARRANTY AND THERE ARE NO WARRANTIES WHICH EXTEND BEYOND THOSE HEREIN. *US WATER* SHALL NOT BE LIABLE FOR ANY INCIDENTAL OR CONSEQUENTIAL DAMAGES.

SOME STATES DO NOT ALLOW THE EXCLUSION OR LIMITATIONS OF INCIDENTAL OR CONSEQUENTIAL DAMAGES SO THE ABOVE LIMITATION MAY NOT APPLY TO YOU. THIS WARRANTY GIVES YOU SPECIFIC LEGAL RIGHTS, AND YOU MAY ALSO HAVE OTHER RIGHTS WHICH VARY FROM STATE TO STATE.

THIS WARRANTY MAY BE TRANSFERRED TO A SUBSEQUENT OWNER WITH WRITTEN APPROVAL OF *US WATER* AND PAYMENT OF STANDARD TRANSFER FEE.

Fusion NLT is a product of US Water Systems.

