

Visit us online at  
[www.uswatersystems.com](http://www.uswatersystems.com)

**US Water**  
systems.com

# US Water Systems

## 56SE Water Softener



AQUATROL™

## Owners Manual

**Models:**

076-AQT-075, 076-AQT-100, 076-AQT-150, 076-AQT-200,  
076-AQT-56SE-SS-100

REVISION # 1.4  
REVISION DATE: October 29, 2018

US Water Systems Corporate Office  
1209 Country Club Road  
Indianapolis, IN 46234

## Table of Contents

Unpacking / Inspection	2
Safety Guide	2
Proper Installation	3
System Dimensions	4
Specifications/Before Starting Installation	5
Total Gallons Calculation	6
How The Water Softener Works	7
Where to Install the Softener	7
Softener Preparation	8
Installation Instructions	11
System Start-up	17
Master Programming	19
Product Features	28
Regeneration Modes	29
Valve Dimensions	31
Assembly Drawings and Parts Lists	32
Valve Wiring	38
Troubleshooting Chart	39
Warranty	40

## Unpacking / Inspection

Be sure to check the entire softener for any shipping damage or parts loss. Also note damage to the shipping cartons. Contact US Water Systems at **1-800-608-8792** to report any shipping damage within 24 hours of delivery. Claims made after 24 hours may not be honored.

## Safety Guide



*For safety purposes, the information in this manual must be followed to minimize the risk of electric shock, property damage or personal injury.*

- Check and comply with provincial / state and local codes. It may be mandatory that these codes/laws be followed.
- Use care when handling the water softening system. Do not turn upside down, drop, drag or set on sharp protrusions.
- The water softening system works on 24 volt-60 Hz electrical power only. Be sure to use only the included transformer.
- Transformer must be plugged into an indoor 120 volt, grounded outlet only.
- Use clean water softening salts only, at least 99.5% pure. Extra Course Grade or Crystal salts are recommended. Do not use rock, block, granulated or ice cream making salts. They contain contaminants that could cause maintenance problems.
- Keep the salt lid in place on the softener unless servicing the unit or refilling with salt.
- **WARNING:** This system is not intended for treating water that is microbiologically unsafe or of unknown quality without adequate disinfection before or after the system. Contact US Water Systems for disinfection treatment equipment.

## Proper Installation

*This water softening system must be properly installed and located in accordance with the Installation Instructions before it is used or the warranty will be void.*

**Do not** install or store where it will be exposed to temperatures below freezing or exposed to any type of weather. Water freezing in the system will break it. Do not attempt to treat water over 100°F.



32° - 100° F

**Do not** install in direct sunlight. Excessive sun or heat may cause distortion or other damage to non-metallic parts.



No Direct Sunlight

Properly ground to conform with all governing codes and ordinances. Use only *lead-free solder and flux* for all sweat-solder connections, as required by state and federal codes.



Conform to all Governing Codes

Maximum allowable inlet water pressure is **125 psi**. If daytime pressure is over 80 psi, night time pressure may exceed the maximum. Use a pressure reducing valve (PRV) to reduce the pressure.

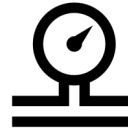

125 Max. PSI

Softener resins may degrade in the presence of chlorine or chloramines. If the feed water contains chlorine or chloramines, reduced life of the resin could occur. In these conditions, it is wise to consider purchasing a whole house carbon filter system with a chlorine reducing media. Contact US Water Systems for Chlorine and Chloramine removal equipment.



2 ppm Max. Chlorine & Chloramine

**WARNING:** Discard all unused parts and packaging material after installation. Small parts remaining after the installation could be a choke hazard.



Discard All Unused Material

## Aquatrol by US Water Systems Dimensions

Aquatrol Water Softeners				
Model	Tank Size	A	B	C
AQT-56SE-SS-100	10" x 40"	50"	40"	10"
AQT-100	9" X 48"	58"	48"	9"
AQT-150	10" X 54"	64"	54"	10"
AQT-200	12" X 52"	62"	52"	12"



## Specifications

Specifications	US Water Aquatrol Water Softeners			
	AQT-56SE-SS-100	AQT-100	AQT-150	AQT-200
Salt Used Per Regeneration	10 lbs	10 lbs	15 lbs	20 lbs
Hardness Removal-Grains	35,000	35,000	53,000	70,000
Resin Quantity - Cubic Feet	1	1	1.5	2
Tank Size	10X40	9X48	10X54	12X52
Brine Tanks Size	11x11x35	15x17x35	15x17x35	15x17x35
Normal Flow Rates	8 GPM	8 GPM	12 GPM	17 GPM
Peak Flow Rates	10 GPM	10 GPM	15 GPM	20 GPM
Backwash Flow Rate	2.4 GPM	2.4 GPM	3.0 GPM	3.5 GPM
Water Used Per Regeneration	96	96	110	125
Plumbing Connections	3/4" NPT			
Electrical Requirements	Input 120V 60 Hz - Output 24V 450mA			
Water Temperature	Min 39 - Max 100 degrees Fahrenheit			
Water Pressure	Min 20 - Max 125 psi			

- Continuous operation at flow rates greater than the service flow rate may affect capacity and efficiency performance.
- The manufacturer reserves the right to make product improvements which may deviate from the specifications and descriptions stated herein, without obligation to change previously manufactured products or to note the change.
- The above capacity and flow rate specifications have not been validated by WQA.

## Before Starting Installation

### Tools, Pipe, and Fittings, Other Materials

- Channel Locks
- Screwdriver
- Teflon tape
- Razor knife
- Two adjustable wrenches
- Additional tools may be required if modification to home plumbing is required.
- Plastic inlet and outlet fittings are included with the softener. To maintain full valve flow, 3/4" pipes to and from the softener fittings are recommended. The same, or larger, pipe size can be used as the water supply pipe, but the outlet piping should be the same as the inlet or smaller.
- Use copper, brass, or PEX pipe and fittings.
- Some codes may also allow PVC plastic pipe.
- ALWAYS install the included bypass valve, or a 3 shut-off valves "H" valve bypass manifold. Bypass valves allow the water to the softener to be bypassed for repairs if needed, but still have water in the house pipes.
- 5/8" OD drain line (not included) is needed for the valve drain.
- Extra Course Grade or Crystal water softener salt (not included) is needed to fill the cabinet or brine tank.



## Total Gallons Calculation

Parameter	US Water Aquatrol Water Softener			
	AQT-56SE-SS-100	AQT-100	AQT-150	AQT-200
Efficiency Capacity Setting	25,000	25,000	37,000	50,000
Brine Fill Setting in Minutes	8	8	10	14

The US Water Systems Aquatrol valve uses a meter to count the gallons of water being treated through the system. Once the gallons programmed in the unit has been exhausted the system will regenerate. The total gallons of treatable water the system can produce is based on the system size and the hardness level of the feed water. A simple calculation is done to determine the amount of gallons to input during the programming portion of the installation. When figuring the capacity in gallons, the number of people, size and the hardness level must all be considered. It is important that the number of people be inputted in the equation below to ensure there is adequate reserved capacity in place.

**ATTENTION: THIS CALCULATION MUST BE COMPLETED TO PROGRAM THE UNIT!**

**Total Gallons = System Capacity in Grains (See chart above) / Hardness in (GPG) Grains per Gallon (determined by a water test) - Number of People X 75 Gallons**

**Example;**

System Capacity: AQT-100 System/25,000 Grains (chart above)  
 Feed Water Hardness: 25 GPG (must be tested onsite by the end user or installer)  
 Number of People: 4

$$25,000 \text{ Grains} / 25 \text{ GPG} - 4 \text{ Number of people} \times 75 \text{ Gallons} = \text{Total Gallons}$$

$$1000 \text{ Gallons} - 300 \text{ Gallons} = 700 \text{ Total Gallons}$$

700 Gallons would be inputted for Total Gallons during programming.

*If the hardness level is given in ppm or mg/L, it can be converted to Grains Per Gallon by dividing the value by 17.1.*

**Example;**

*Hardness Level 345 ppm or mg/L*

*345 pm or mg/L / 17.1 = 20.18 GPG. In this case round up to 21 GPG*

**Input the site values in the equation below to figure the total gallons value.**

\_\_\_\_\_ Grains / \_\_\_\_\_ GPG - \_\_\_\_\_ Number of people X 75 Gallons = Total Gallons

\_\_\_\_\_ Gallons - \_\_\_\_\_ Gallons = \_\_\_\_\_ Total Gallons

## How The Water Softener Works

The principle behind water softening is simple chemistry. A water softener contains resin beads which hold electrically charged ions. When hard water passes through the softener, calcium and magnesium ions are attracted to the charged resin beads. The result is removal of calcium and magnesium ions which produces soft water.

This system is controlled with simple, user-friendly electronics displayed on a LCD screen.

## Where To Install The Softener

- Place the softener as close as possible to the pressure tank (well system) or water meter (city water).
- Place the softener as close as possible to a floor drain, or other acceptable drain point (laundry tub, sump, standpipe, etc.).
- Connect the softener to the main water supply pipe **BEFORE** the water heater. **DO NOT RUN HOT WATER THROUGH THE SOFTENER.** Temperature of water passing through the softener must be less than 100 deg. F.
- Outside faucets and irrigation systems should be supplied with hard water prior to the water softener. If this is not possible, be sure to bypass the softener when watering grass or plants. Chronic soft water exposure can be detrimental to plant life.
- Do not install the softener in a place where it could freeze. **Damage caused by freezing is not covered by the warranty.**
- Put the softener in a place where water damage is least likely to occur if a leak develops. The manufacturer will not repair or pay for water damage.
- A 120 volt electric outlet is needed within 6 feet of the softener. The transformer has an attached 8 foot power cable. **Be sure the electric outlet and transformer are in an inside location, to protect from wet weather.**
- If installing in an outside location, you must take the steps necessary to assure the softener, installation plumbing, wiring, etc. are protected from the elements and contamination sources.
- **Keep the softener out of direct sunlight.** The sun's heat may soften and distort plastic parts.

Unwrap and lay out the parts in the brine tank. The following parts should be with each system;

- Control Valve (1)
- Funnel (2)
- Upper Distributor Basket (3)
- Brine Line (4)
- Power Transformer (5)

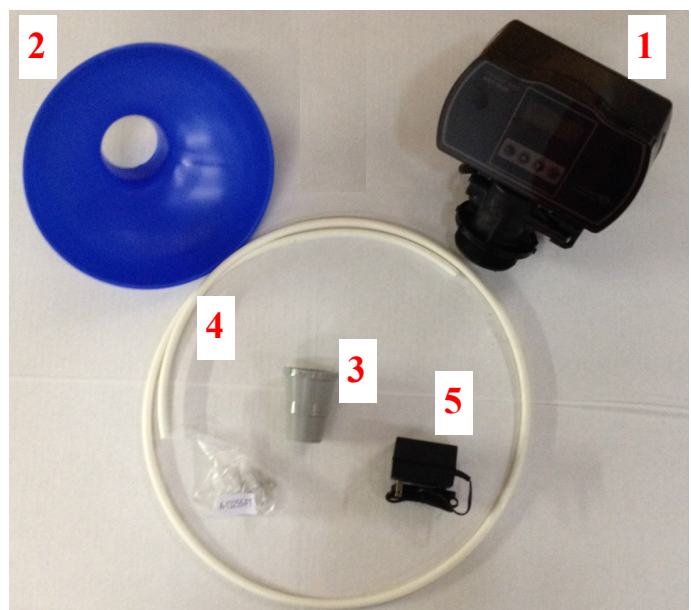

## Softener Preparation

### *Aquatrol Tank Installation Instructions*

**WATER PRESSURE:** A minimum of 20 pounds of water pressure is required for regeneration valve to operate effectively.

**ELECTRICAL FACILITIES:** An uninterrupted alternating current (A/C) supply is required. Please make sure your voltage supply is compatible with your unit before installation.

**EXISTING PLUMBING:** Condition of existing plumbing should be free from lime and iron buildup. Piping that is built up heavily with lime and/or iron should be replaced.

**LOCATION OF AQUATROL TANK AND DRAIN:** The Aquatrol tank should be located close to a drain to prevent air breaks and back flow.

**CAUTION:** Water pressure is not to exceed 80 psi, water temperature is not to exceed 110°F (43°C), and the unit cannot be subjected to freezing conditions.

### *Media Installation*

- 1) Remove the resin tank from carton.
- 2) Verify the riser tube is centered in the bottom center of the tank. A flashlight may be necessary. There is an indentation in the bottom of the tank that will center the distributor tube.

**NOTE:** The AQT-56SE-SS-100 unit tank riser tube is secured in the center and does not require centering. However, the riser tube in this unit should be secured in the bottom the tank and should not pull out.





## Softener Preparation

3) Place a piece of duct tape over the riser tube so no resin enters the riser while filling.

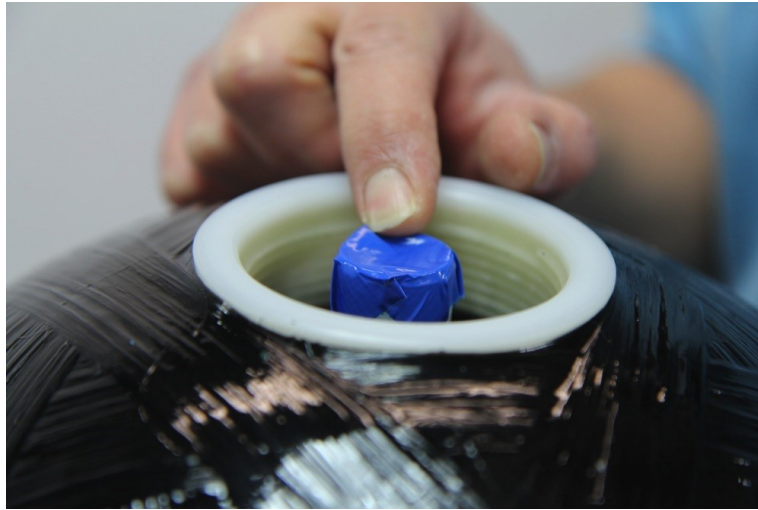

4) Use the Blue Funnel provided, to pour the softening resin into the tank. Pour it evenly around the hole to ensure it is well distributed in the tank and pour slow enough, to keep from plugging the hole. A helper may be needed to hold the funnel during the filling process. It is recommended that a dust mask and safety goggles be worn to prevent possible injury. Pour all the resin sent with the system in the tank. US Water does not ship "extra" resin.



5) When the resin is installed move tank side to side to settle the media. Remove the funnel and tape from the distributor tube.

## Softener Preparation

6) Lubricate both O-rings on the bottom of the control valve (center and outer). Install the upper basket on the bottom of the valve by lining up the tabs then turning the basket clockwise to lock it in place. Place the upper basket over the distributor tube and push the valve on the tank. Thread the valve on the tank by turning it clockwise. Be sure not to cross-thread the valve on the tank. The valve should thread easily in the tank. If not, it may be cross-threaded. Tighten the valve hand tight, then snug it further by tapping it with the palm of the hand. **DO NOT** use tools to tighten the valve or damage could occur.



## Installation Instructions

1. If the hot water tank is electric, turn off the power to it to avoid damage to the element in the tank.
2. If the source is a private well, turn the power off to the pump and then shut off the main water shut off valve. If the source is municipal water, simply shut off the main valve. Go to the faucet, (preferably on the lowest floor of the house) turn on the cold water until all pressure is relieved and the flow of water stops.
3. Locate the softener tank and brine tank close to a drain where the system will be installed. The surface should be clean and level.
4. Connect the inlet and outlet of the softener using appropriate fittings. Perform all plumbing according to local plumbing codes.

- **ON COPPER PLUMBING SYSTEMS BE SURE TO INSTALL A GROUNDING WIRE BETWEEN THE INLET AND OUTLET PIPING TO MAINTAIN GROUNDING.**

Any solder joints being soldered near the valve must be done before connecting any piping to the valve. Always leave at least 6" (152 mm) between the control valve and joints being soldered when soldering pipes that are connected to the valve. Failure to do this could cause damage to the valve.

The Aquatrol is equipped with 3/4" male NPT connections. It is recommended that these connections are made using Teflon tape.

The inlet and outlet can be identified on the bypass valve. There are arrows stamped in the bypass valve showing flow. The arrow pointing toward the valve is the inlet and the arrow pointing away from the valve is the outlet.

**All piping should be secured to prevent stress on the bypass valve and connectors.**



## Installation Instructions

5. Connect the drain hose to the valve and secure it with a hose clamp. Run the drain hose to the nearest laundry tub or floor drain. This can be ran up overhead or down along the floor. Drain hose should be a minimum of 1/2". If running the drain line more than 20 ft linear, it is recommended to increase the hose size to 3/4" and be sure there is no sags and a "drop" in the pip all the way to the drain destination. A DIRECT CONNECTION INTO A WASTE DRAIN IS NOT RECOMMENDED. A PHYSICAL AIR GAP OF AT LEAST 1.5" SHOULD BE USED TO AVOID BACTERIA AND WASTEWATER TRAVELLING BACK THROUGH THE DRAIN LINE INTO THE SOFTENER.

**Hose barb fitting for drain line.  
Be sure to use a hose clamp to  
secure the line.**

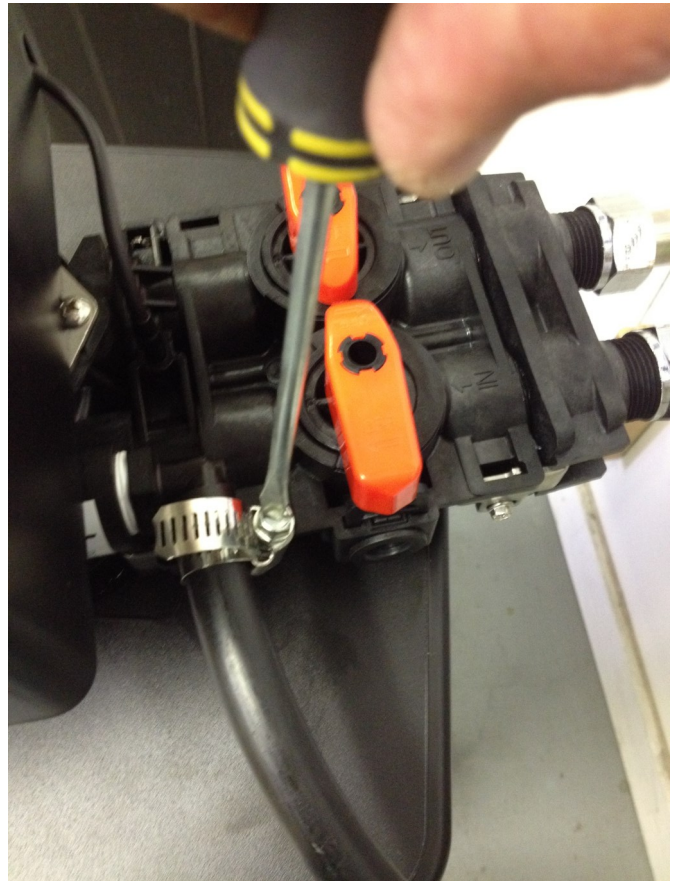
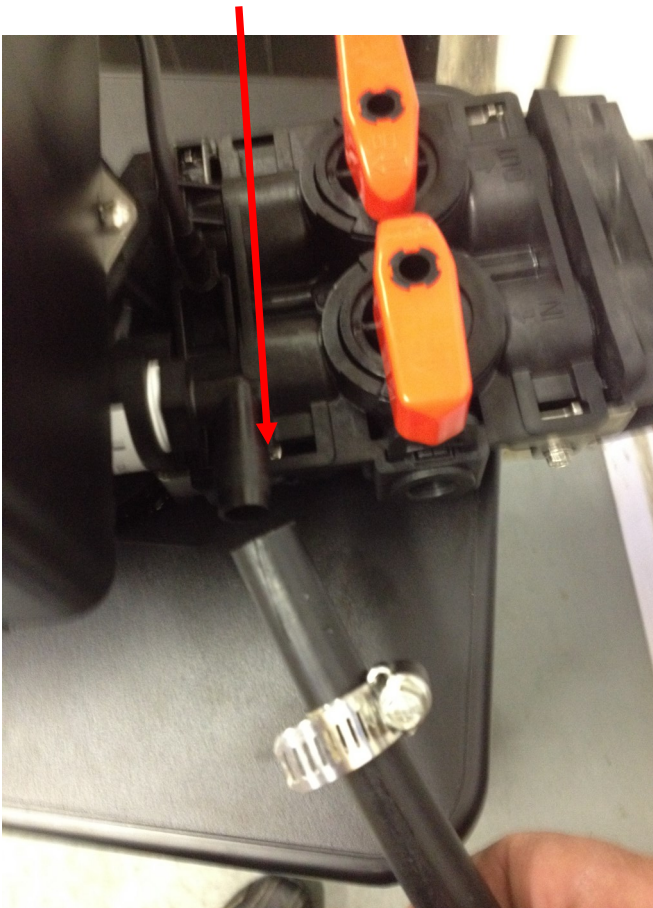

**Be sure to secure the drain line. The softener will drain with force and it should be secured to prevent a leak. Hose clamps should be used to secure the drain line at the connection points. Drain lines should be installed with the least amount of back pressure possible.**

## Installation Instructions

6. Connect the brine line to the control valve by removing the blue lock clip. Then push the brine line in the fitting until it is fully seated. Then re-install the blue lock clip.

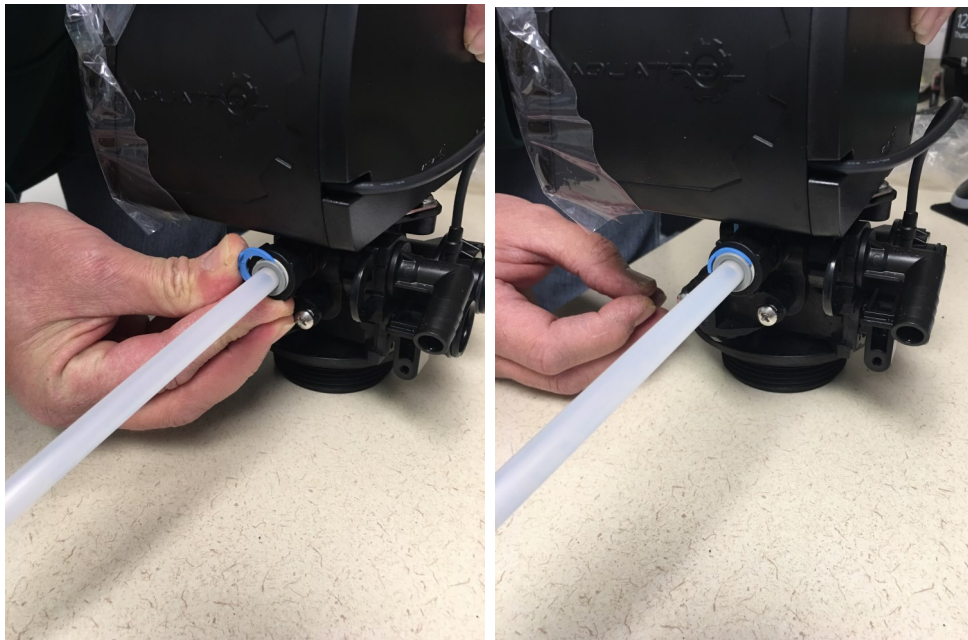

## Installation Instructions

7. Now connect the brine line to the brine tank . Remove the cap on the white brine well in the tank and push the brine line through the hole in the side of the tank and brine well.

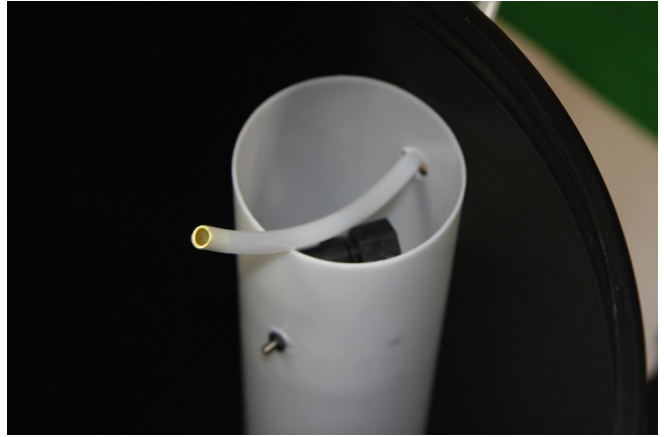

8. Remove the nut and sleeves from the brine safety valve in the brine well. BE CAREFUL not to drop the sleeves in the tank. Install the nut on the brine line first.



9. Install the “split” sleeve on the brine line with the tapered part facing the nut.

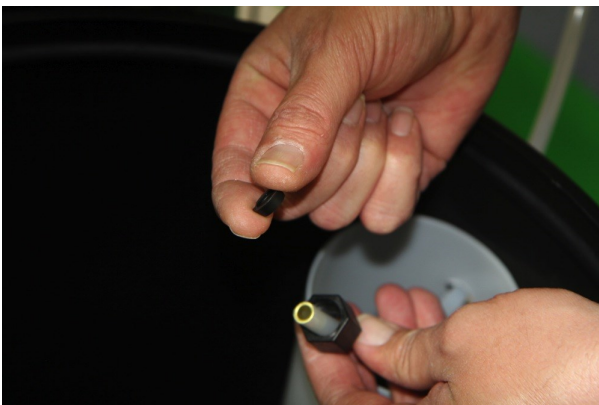

## Installation Instructions

10. Now slide the “shoulder” sleeve on the brine line with the larger diameter “shoulder” facing the brine nut.



11. Be sure the tube stiffener is in place. It may be brass or plastic, either can be used. Push the brine line in the elbow on the brine safety valve in the brine well until it stops. Tighten the nut hand tight then turn it another 1/2 to 1 full turn with channel locks.



12. Pour in at least two bags of salt and 5 gallons of clean water.

## Installation Instructions

13. Place the unit in the bypass position (see below). Slowly turn on the main water supply. At the nearest cold treated water tap nearby remove the faucet screen, open the faucet and let water run a few minutes or until the system is free of any air or foreign material resulting from the plumbing work.
14. Make sure there are no leaks in the plumbing system before proceeding. Close the water tap when water runs clear.
15. Open the brine tank lid and add 5 gallons of water to the brine tank. Add a minimum of 80lbs of salt to the brine tank.
16. Proceed to start up instructions.

**BYPASS POSITION**



**SERVICE POSITION**



**Note:** *The unit is not ready for service until you complete the start-up instructions.*



# System Start-Up

## Key Pad Configuration

<b>“Settings”</b>	This function is to enter the programming mode required at the time of installation. This button serves as the “Save” button.
<b>“Cycle”</b> <small>(Triangle Arrows)</small>	This function is to initiate a regeneration. This button also unlocks each parameter to be changed in the programming mode.
<b>DOWN / UP</b>	Increase or decrease the value of the settings while in the programming mode.



## Manual Regeneration (Step / Cycle Valve)

### IMMEDIATE REGENERATION

To start an immediate regeneration, press and hold the “Cycle” button. Button for 3-5 seconds. The valve will start an immediate regeneration.

### DELAYED REGENERATION

To queue a delayed regeneration push and release the “Cycle” button. The on screen

water spigot will be flashing. The flashing spigot indicates a regeneration queued for next programmed. regeneration times.

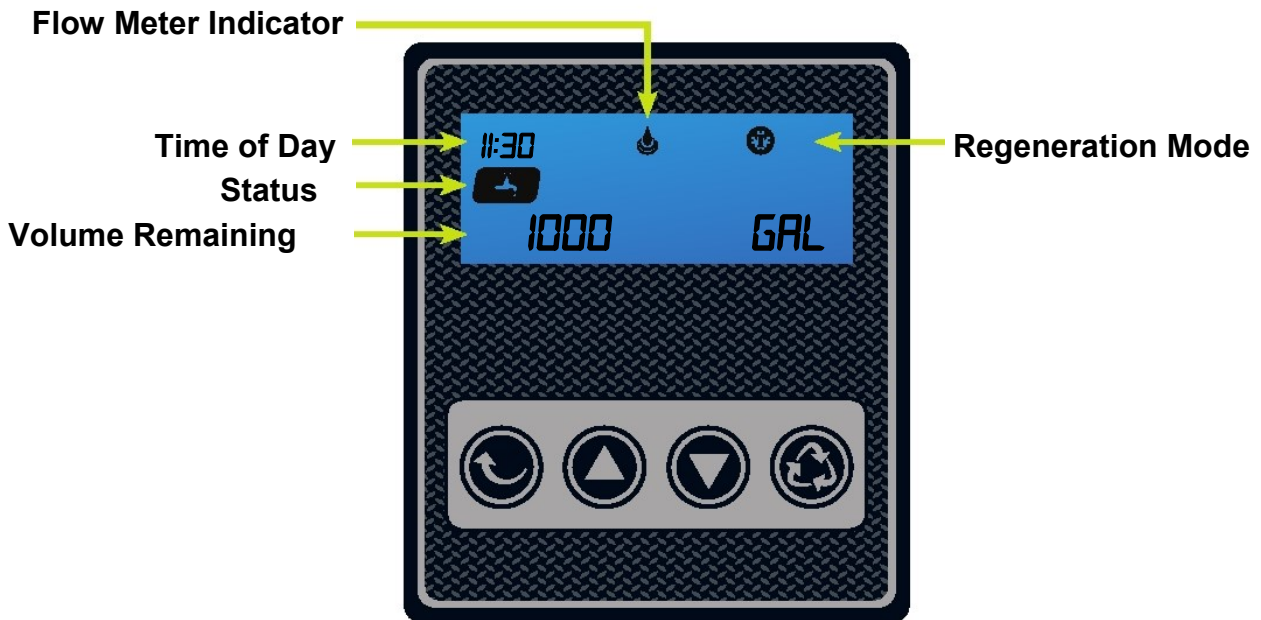

## System Start-Up

### Start-up Instructions

1. Plug the power transformer into an approved power source. Connect the power cord to the valve.
2. When power is supplied to the control, the screen will display the time of day, gallons remaining and the mode. Press and hold the "Cycle" button. The valve will display "**GOTO BW**" and will continue to move until it reaches the backwash system.
3. Once the valve is in the backwash (BW) cycle the display will show a time value (10), open the inlet on the bypass valve slowly and allow water to enter the unit. Air from the tank will begin to push out of the control valve drain. Allow all air to escape from the unit before turning the bypass fully open. If there is a large "knocking" sound, the water is being fed too quickly and should be slowed. Once there is a steady stream of water coming from the system drain with no air coming out, allow water to run to drain for 3-4 minutes or until all media/resin fines are washed out of the softener which is indicated by clear water in the drain hose.
4. When the backwash cycle is complete, the valve will advance to the brine draw (BD) position. Once the valve reaches the BD cycle, push and release the "Cycle" button. The display will show "**GOTO RR**" (Rapid Rinse). Once the valve reaches the rinse cycle, allow the water to run for the entire rinse cycle.
5. When the rinse cycle is complete, the valve will advance to the "BF" position. Once in the brine fill position, check that the control valve is pushing water into the brine tank (remove brine well cap to confirm that the water level is rising in the brine tank). Allow the valve to refill for the full amount of time as displayed on the screen to insure a proper brine solution for the next regeneration.
6. When the refill cycle is complete, the valve will automatically advance to the SERVICE position. Open the outlet valve on the bypass, then open the nearest treated water spigot or faucet (remove faucet screen to prevent clogging) and allow the water to run until clear, close the tap and replace the faucet screen.
7. Program unit.

# Master Programming

## First Step-Setting Time of Day

Press Simultaneously



Default setting 12:00 (24 hours)  
 Press Setting Button and Up Button  
 simultaneously to enter into Programing  
 Mode.



▲  
Flashing



## Set the hour

Press Up or Down buttons  
 to change hours.



Press the Settings Button  
 to accept and continue.



Flashing  
▼



## Set the Minutes

Press Up or Down buttons  
 to change minutes.



Press the Settings Button  
 to accept and continue.



Flashing  
▼

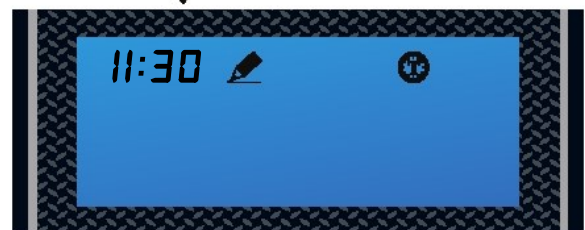

# Master Programming

## Second Step - Setting the Regeneration Mode



Default setting is "Timer"

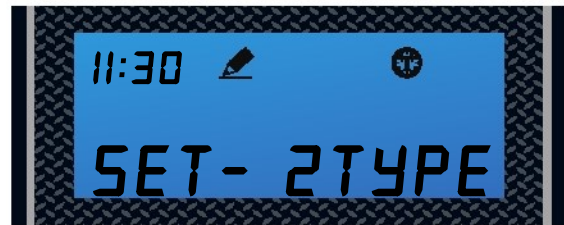

Flashing



## Choose Between Time, Meter Immediate or Meter Delayed

Timer  
This mode will  
Not show water  
capacity options.



Flashing



Press Up or Down buttons  
to change minutes.

Meter immediately



Flashing

Press the Settings Button  
to accept and continue.

Meter Delay



Flashing

# Master Programming

## Third Step - Setting the Unit Capacity (Not shown if Timer Mode was selected in 2nd Step)



Default setting is 1000 Gallons



Flashing



## Set Unit Measurement - Gallons, Liters or Cubic Meters

Press Up or Down buttons to Change Unit between:



Gal: Gallon  
L: Liter  
M3: Cubic Meter



Press the Settings Button to accept and continue.

Gallons



Flashing

Liters

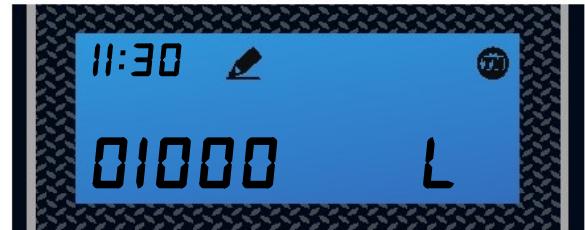

Flashing

Cubic Meters



Flashing

# Master Programming

Default setting is 1000 Gallons

Press Up or Down buttons to set water capacity



Press the Settings Button to accept, cursor moves left and the number flashes.

**Attention!**  
Enter the number of gallons that was determined on the Page 6 worksheet. This worksheet must be completed to determine the proper gallons.



▲  
Flashing

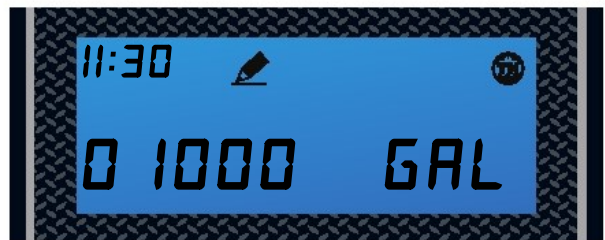

▲  
Flashing

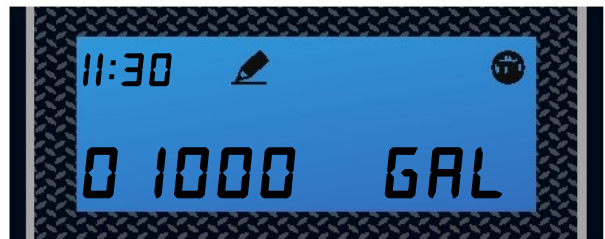

▲  
Flashing

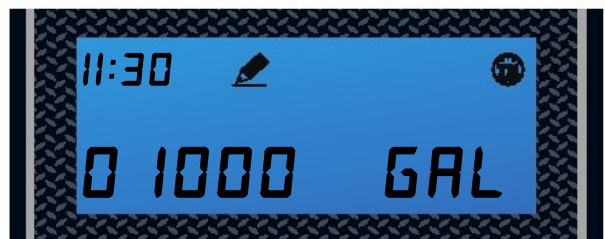

▲  
Flashing

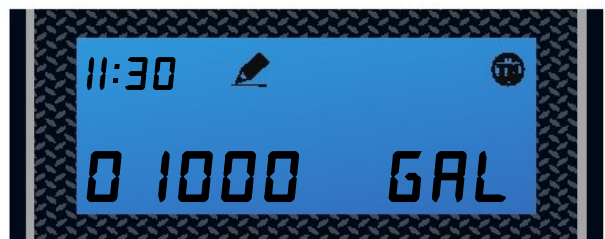

▲  
Flashing

# Master Programming

## Fourth Step - Regeneration Time and Hours Override

---



▲  
Flashing

### Meter Delay Modes

---

Default: 2:00 a.m - OFF  
Hours Override range:  
Every 24 hours (Set to 336)



Use UP or DOWN Buttons to adjust the Regeneration Time

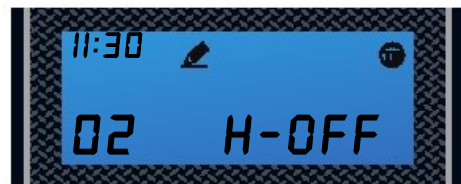

▲  
Flashing

Press SET to go to Hours Override

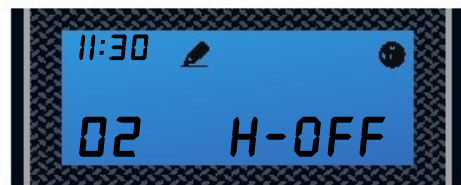

▲  
Flashing

Use UP or DOWN Buttons to adjust the Hours Override

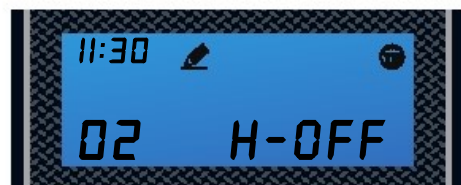

▲  
Flashing

# Master Programming

## Fifth Step - Setting the Back Wash Time



Flashing



### Set the Time

Default setting is 015

Use UP or DOWN Buttons to change Back Wash time (minutes)  
Range: 0-999



Press the Setting Button to accept and continue to next digit



Flashing

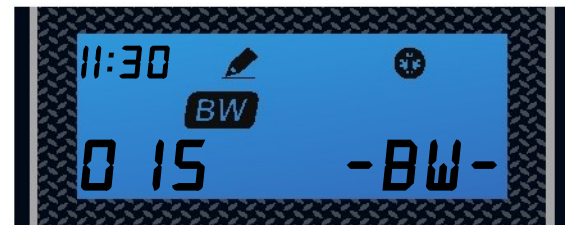

Flashing



Flashing



# Master Programming

## Sixth Step - Setting the Brine Time



Flashing



### Set the Time

Default setting is 060

Use UP or DOWN Buttons to change Brine time (minutes)  
Range: 0-999



Press the Setting Button to accept and continue to next digit

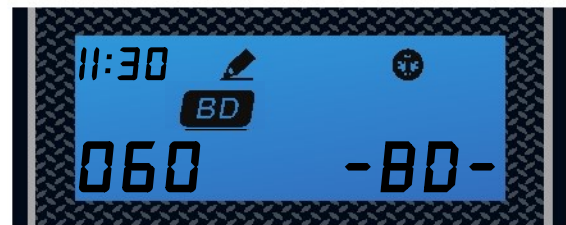

Flashing



Flashing

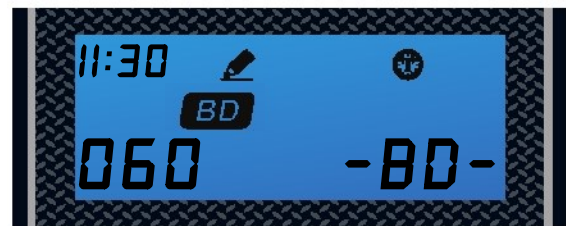

Flashing

# Master Programming

## Seventh Step - Setting the Rapid Rinse Time

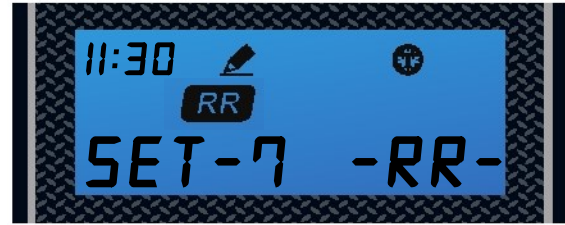

Flashing



### Set the Time

Default setting is 010

Use UP or DOWN  
Buttons to change  
Rapid Rinse time  
(minutes)  
Range: 0-999



Press the Setting  
Button to accept  
and continue to  
next digit



Flashing



Flashing

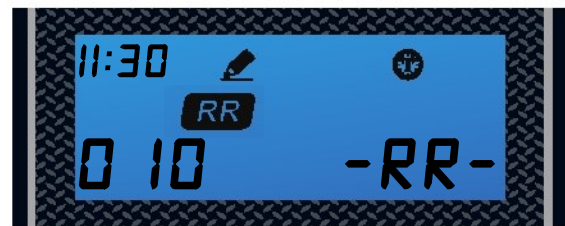

Flashing

# Master Programming

## Eighth Step - Setting the Brine Fill Time



▲  
Flashing



### Set the Time

Default setting is 012

Use UP or DOWN Buttons to change Brine Fill time (minutes)  
Range: 0-999



Press the Setting Button to accept and continue to next digit



▲  
Flashing



▲  
Flashing



▲  
Flashing

## Attention!

Use the table below to determine the proper BF setting for your unit.

Parameter	US Water Aquatrol Water Softener			
	AQT-56SE-SS-100	AQT-100	AQT-150	AQT-200
Efficiency Capacity Setting	25,000	25,000	37,000	50,000
Brine Fill Setting in Minutes	8	8	10	14

## Product Features

### Display in Service

#### Meter Delay Regeneration Mode

The display will show the current time and the remaining treated water alternatively. When the remaining treated water counts down to zero the display changes to the regeneration time set by the user.



#### Backlight Screen

The backlight on the screen will go off automatically after one minute if no buttons are pressed. To light it up again press any button on the touch pad.

#### Memory during power failure

All program settings are stored in permanent memory. Current valve position, cycle step elapsed, time of day are stored during the power failure. Reset the current time is necessary when power up.

If the valve stopped at a regeneration stage when power failure, the valve will return to prior position when power up. It takes 4 to 5 minutes to reset to the position.

The display shows as:

The system will show the status when power failure after finding the position of the valve.



#### Restore factory settings

- 1) Pull out the power
- 2) Press the  button and plug in the power simultaneously
- 3) Release the  button

The system is now restored.



# Regeneration Modes

## Queued (Delayed) Regeneration

When the valve is in service position press the  button to activate the queued regeneration.

Queued (Delayed) regeneration means the system will initiate a regeneration at the programmed regeneration time. If it is missed due to power failure it will regenerate on the next day.

The display shows the Queued (Delayed) Regeneration in Meter Delay Mode

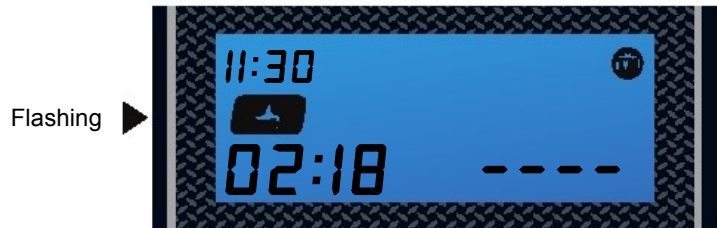

The system will initiate a regeneration - either the treated water remaining counts down to zero or the remaining time counts down to zero, whichever is first.

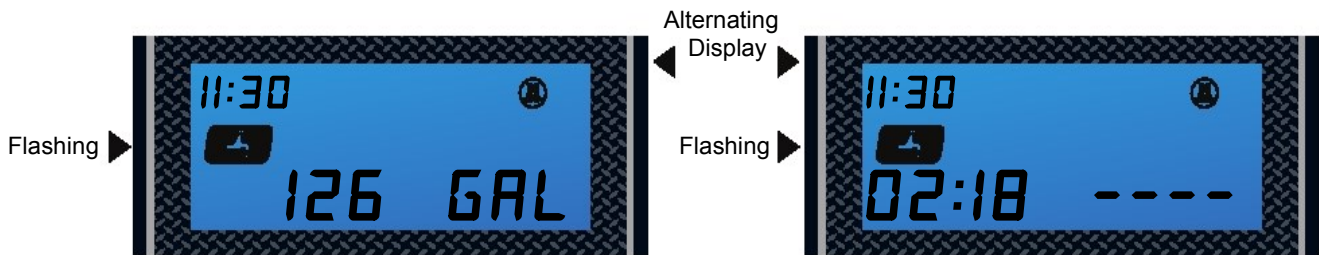

# Regeneration Modes

## Immediate Regeneration

When the valve is in service position press and hold the  button for 5 seconds, an immediate regeneration will be initiated.

**Examples:**

“BW” Flashing (ready to “Backwash”)



When the time counts down to zero or press the  button

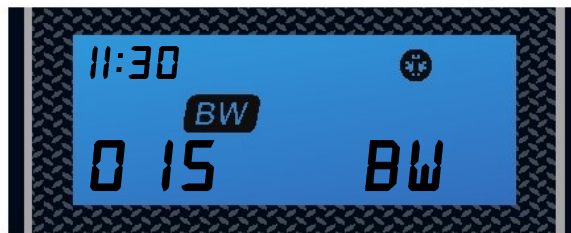



“BD” Flashing (ready to “brine”)



The display shows as:

**Stop Regenerating**

When regenerating, press the   simultaneously, the system will stop regenerating the display will start to return to the service position.



## Valve Dimensions

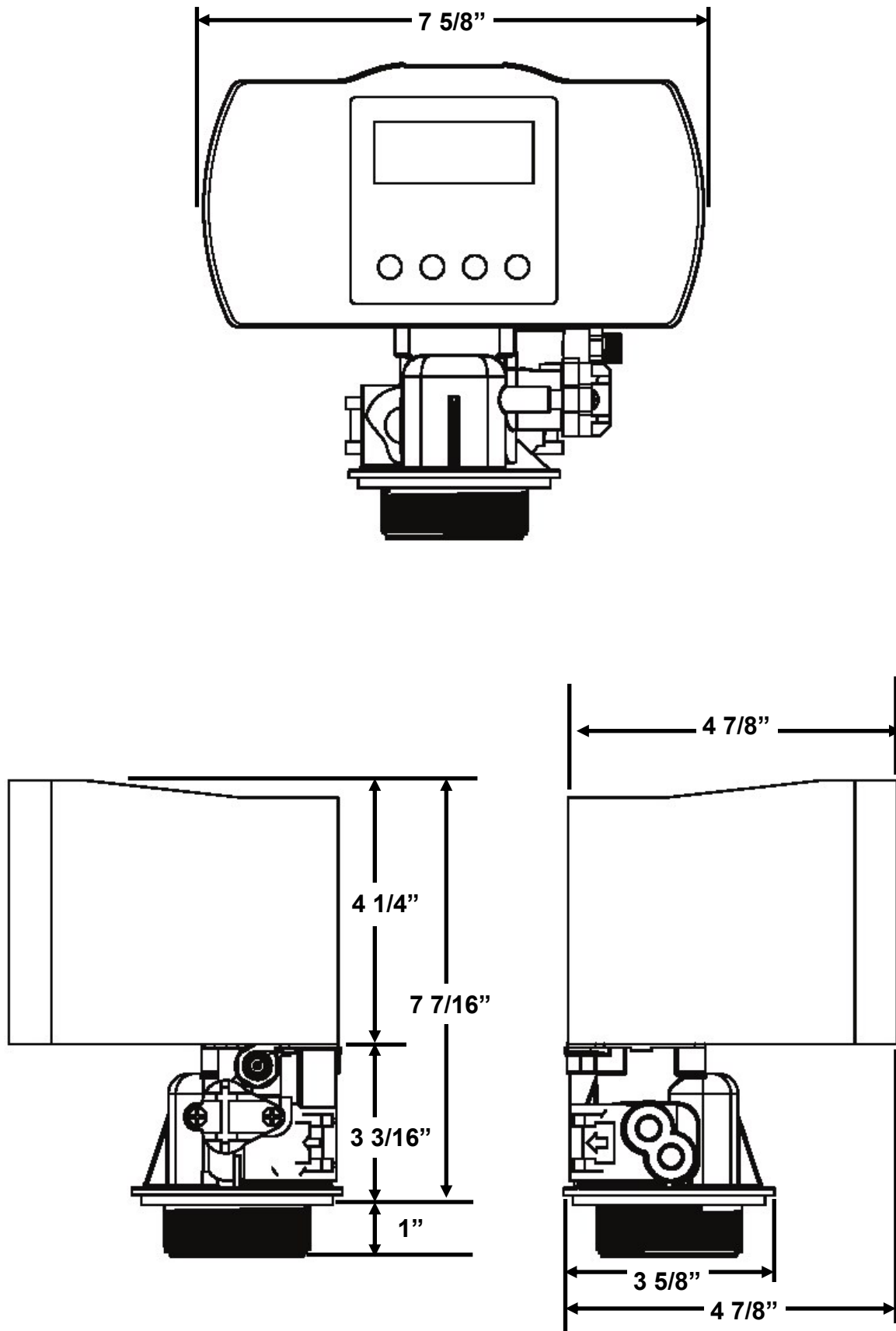

## Meter Assembly

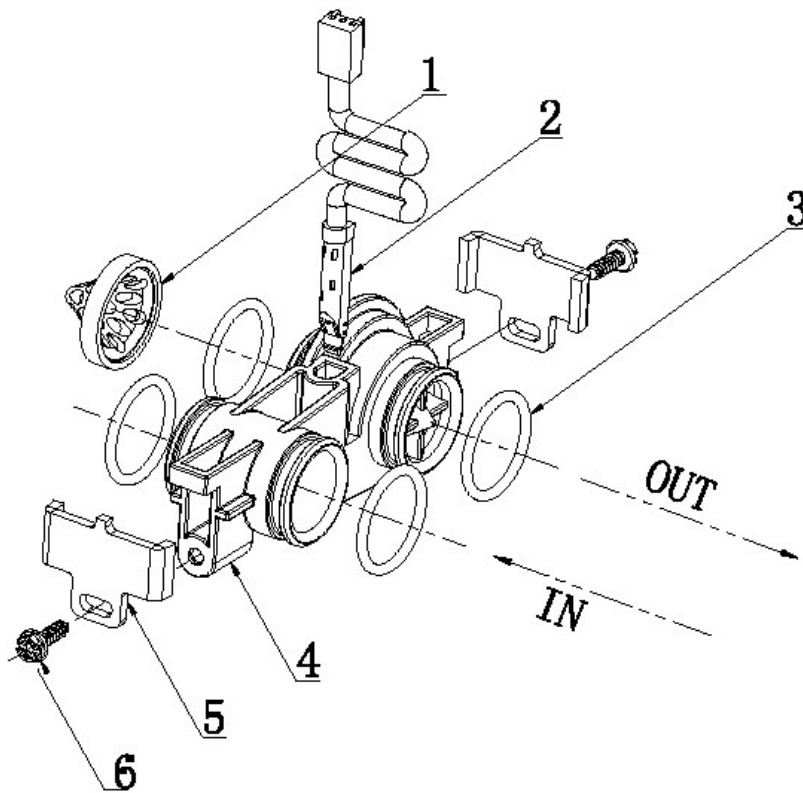

Item No.	Quantity	Part No.	Description
1	1	56013	Flow Straightener
2	1	50022-3	Meter Cable Assembly
3	4	01013	O-ring
4	1	1220E	Meter Body Assembly
5	2	50044	Adapter Clip
6	2	02105	Screw



# Powerhead Assembly

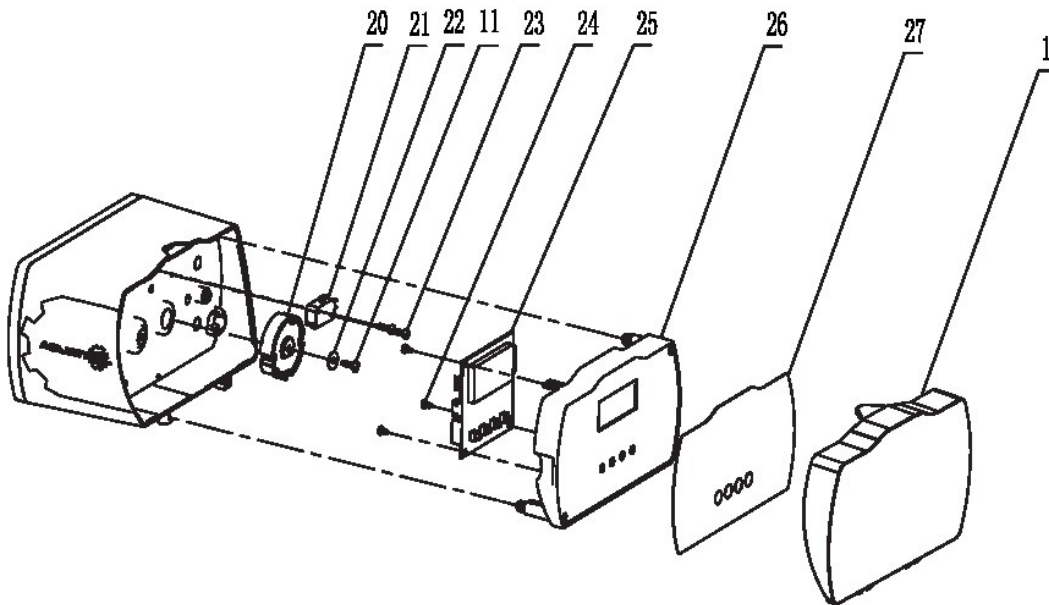
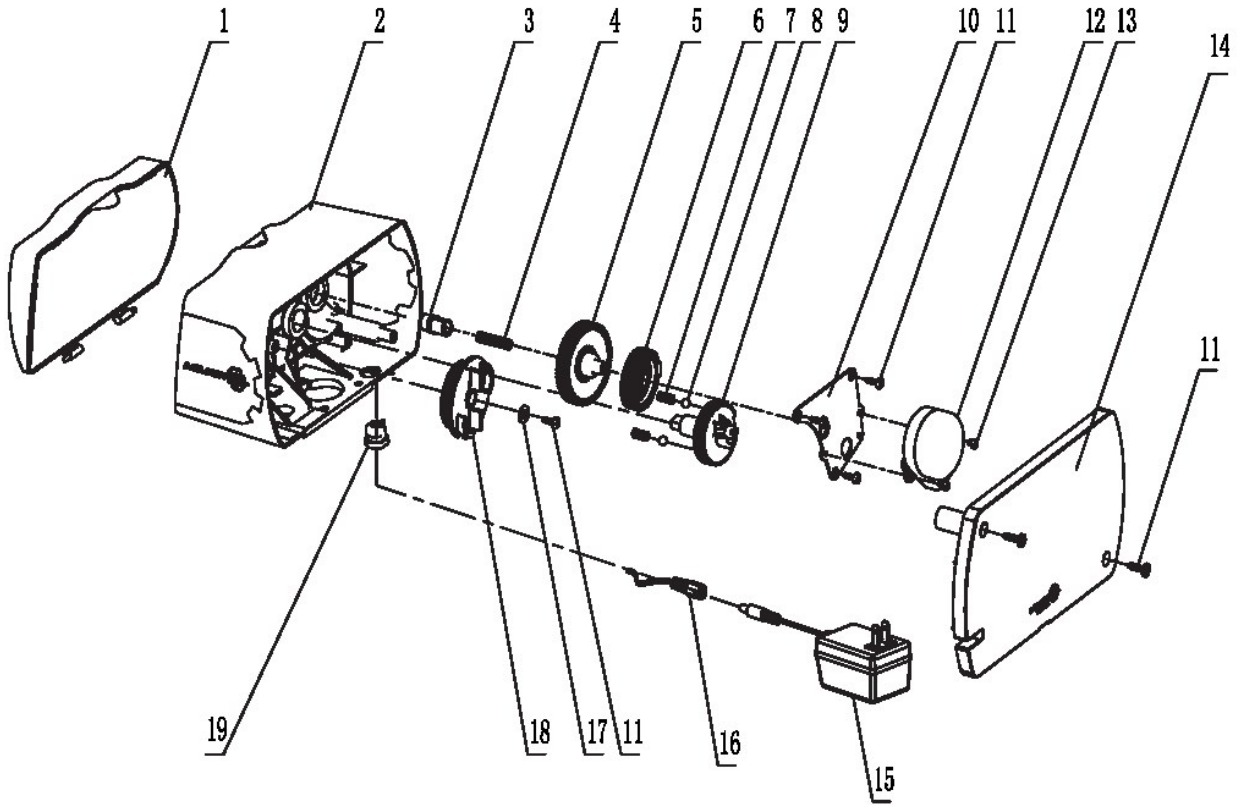

## Powerhead Assembly

Item No.	Quantity	Part No.	Description
1	1	A-15613	Front Cover
2	1	A-S0001	Housing Assembly
3	1	A-15616-1	Idler Pointer
4	1	A-13312	Spring Idler
5	1	A-13017	Idler Gear
6	1	A-15617	Drive Gear
7	2	A-14457	Spring
8	4	A-13300	Ball
9	1	A-15622-1	Main Gear and Shaft
10	1	A-15650	Motor Mounting Plate
11	7	A-13296	Screw
12	1		Motor
13	2	A-11384	Screw
14	1	A-15614	Back Cover
15	1		Transformer
16	1	07021	DC Mono Socket
17	1	A-12037	Washer
18	1	A-S1002	Brine Cam Assembly
19	1	A-13547	Strain Relief
20	1	15619	Drive Cam
21	1	06003	Switch
22	1	A-04002	Washer
23	2	02054	Screw
24	3	02015	Screw
25	1	07089	Circuit Board
26	1	S1003	Panel
27	1	A-56296	Front Label

## Control Valve Assembly

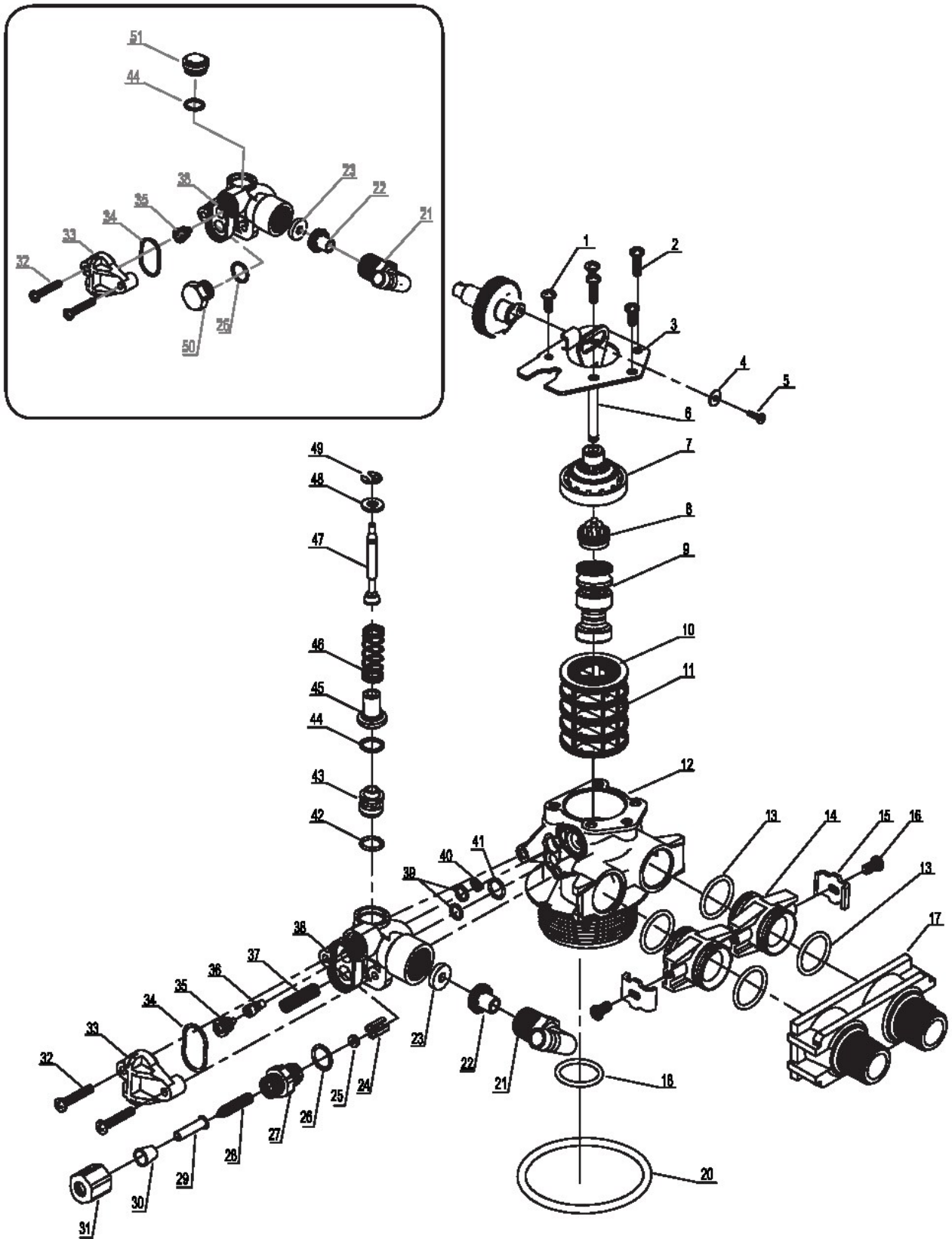

## Control Valve Assembly

Item No.	Quantity	Part No.	Description
1	3	A-02001	Screw
2	2	A-02002	Screw
3	1	A-13546	End Plug Retainer
4	1	A-13363	Washer
5	1	A-13296	Screw
6	1	66133	Piston Rod Assembly
7	1	A-13446	End Plug Assembly
8	1	56115	Piston Retainer
9	1	A-13247	Piston, Softener
10	5	A-13242	Seal
11	4	A-14241	Spacer
12	1	56256-1	Valve Body Assembly
13	4	A-13305	O-ring
14	2	A-19228	Adapter Coupling
15	2	A-13255	Adapter Clip
16	2	A-13314	Screw
17*	1		Yoke, Plastic
18	1	A-13304	O-ring
20	1	01071	O-ring
21	1	A-13308	Brine Hose Barb, Straight
		A-56011	Brine Hose Barb, 90 Elbow
22	1	A-13173	DLFC Button Retainer Assembly
23*	1		DLFC Button
		A-13245	DLFC Button Retainer
25*	1		BLFC Button
26	1	A-12977	O-ring
27	1	A-13244	BLFC Fitting
28	1	A-12767	Screen
29	1	A-10332	BFLC Tube Insert
30	1	A-10330	BFLC Ferrule

## Control Valve Assembly

Item No.	Quantity	Part No.	Description
31	1	A-10329	BLFC Fitting Nut
32	2	A-13315	Screw
33	1	A-13166	Injector Cover
34	1	A-13303	O-ring
35*	1		Nozzle
36*	1		Throat
37	1	A-10227	Screen
38	1	A-13163	Injector Body
39	2	A-13301	O-ring
40	1	A-13497	Air Dispenser
41	1	A-12638	O-ring
42	1	A-13302	O-ring
43	1	A-13167	Brine Valve Spacer
44	1	A-01003	O-ring
45	1	A-13165/A-12550	Brine Valve Cap Assembly
46	1	A-11973	Spring
47	1	A-13172/A-12626	Brine Piston Assembly
48	1	A-16098	Washer Assembly
49	1	A-11981	Ring
50	1	A-13918	BLFC, Plug
51	1	A-13857	Brine Valve, Plug

# Valve Wiring

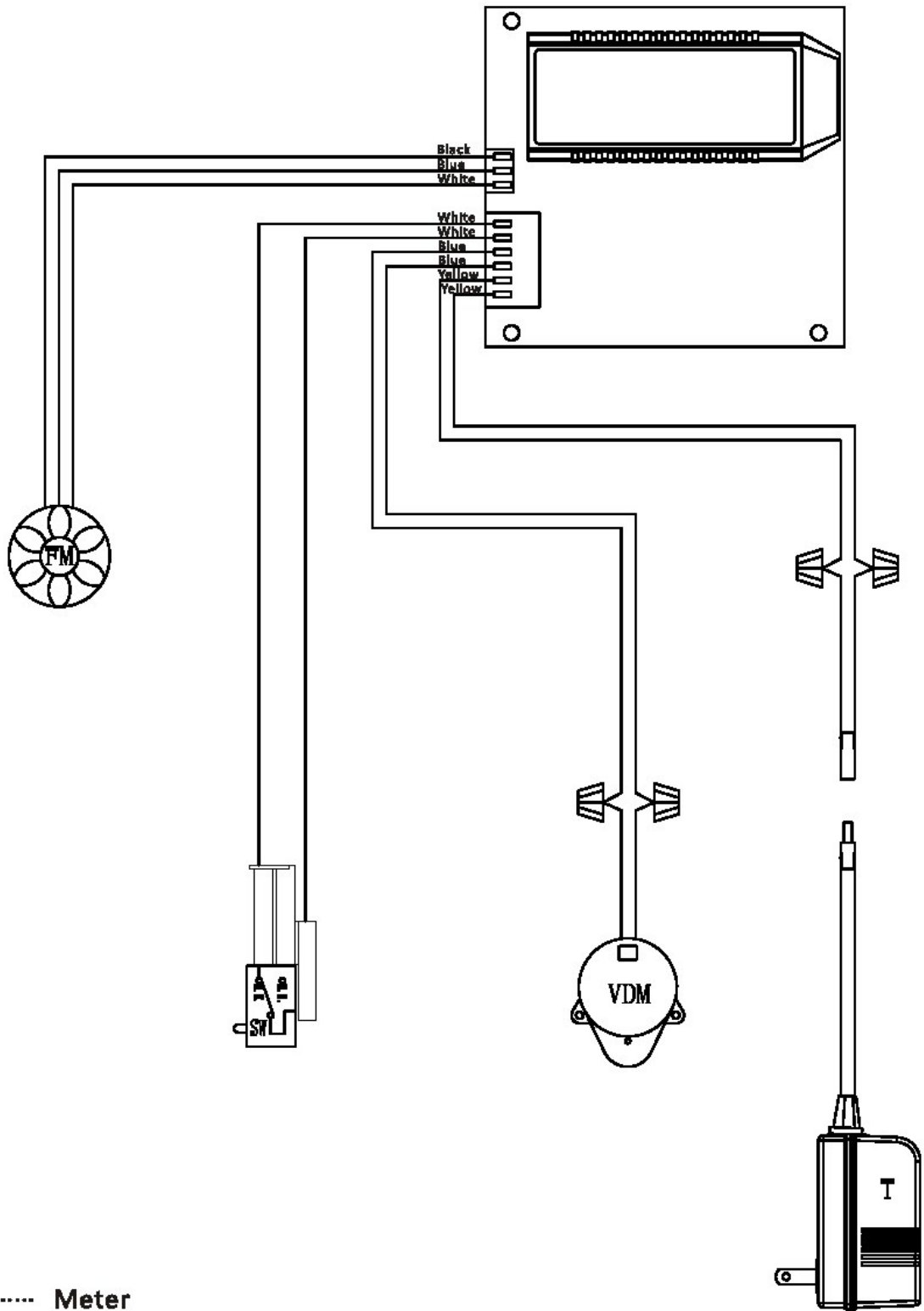

- FM ..... Meter
- SW ..... Valve Homing Switch
- VDM ..... Motor
- T ..... Transformer(24V)

## Troubleshooting

Problem	Cause	Correction
1) The control fails to Regenerate automatically	A) Disconnected meter cable	A) Reconnect the meter cable
	B) Transformer damaged	B) Replace the transformer
	C) Electronic controller or sensor damaged	C) Replace or repair
2) Regeneration at wrong time	aged	A) Reset timer
3) loss of capacity	A) Increase draw water hardness	A) reset unit to the new capacity
	B) Brine concentration or quantity	B) Keep brine tank full of salt at all times. Clean it yearly. Salt may be bridged. If using a salt grid Plate insure refill water is over it
	C) Rinse fouling	C) Consolidate the rinse time, clean the resin and prevent future fouling
	D) Poor distribution, channeling (Uneven bed service)	D) Check distributor and backwash flow
	E) Internal control leak	E) Replace the spacer, seal or piston
	F) Aging of resin	F) Check for resin oxidation caused by Chlorine. Mushy resin
	G) Loss of resin	G) Check for correct bed depth. Broken distributors. Air or gas in bed: Well gas Eliminator loose brine line
4) Poor water quality	A) Check items listed in Problem # 3	A) Check items listed in Correction # 3
	B) Bypass is open	B) Close the bypass
	C) Channeling	C) Check for too slow or high service flow
5) Excessive salt use	A) High salt setting	A) adjust salt setting
	B) Excessive water in brine tank	B) refer to problem # 7 tank
6) Loss of water pressure	A) Fouling of inlet pipe	A) Clean or replace the pipeline
	B) Fouled resin	B) Clean the resin. Pretreat to prevent
	C) Improper backwash	C) Too many resin fines. Reset the flow rate and time of backwash
7) Excessive water in brine tank	A) Plugged drain line	A) Check drain line and clean flow control
	B) Brine valve plugged or damaged	B) Clean or replace the brine valve
	C) Injector plugged	C) Clean injector, replace injector screen
	D) Low inlet water pressure	D) Increase water pressure to allow Injector to perform properly
8) Softener fails to brine draw	A) Plugged drain line	A) Clean drain line and flow control
	B) Plugged injector	B) Clean or replace the injector and screen
	C) No water in the brine tank	C) Check for restriction in B.L.F.C. Ensure Safety float is not stuck
	D) Low water pressure	
	E) Brine line injects air during brine draw	D) Increase water pressure
	F) Internal control leak	E) Check brine line for air leaks
9) Control cycles continuously	A) Faulty timer	F) Check seal, spacer and piston for scratches and dents
10) Continuous flow to drain	A) Foreign material in the control	A) Replace timer
	B) Internal control leak	A) Call dealer. Clean valve, rebuild unit
	C) Piston jammed in brine or back wash position	B) Same as above C)



# WARRANTY

**US Water Systems** warrants that your new water conditioner is built of quality material and workmanship. When properly installed and maintained, it will give years of trouble free service.

## Five Year Valve, Electronics and Resin Guarantee

**US Water Systems** will replace any part on the valve or electronics which fails or the softening resin within (5) five years from date of manufacture, as indicated by the serial number, provided the failure is due to a defect in material or workmanship. The only exception shall be when proof of purchase or installation is provided and then the warranty period shall be from the date thereof. Resin and internal control valve parts will not be covered for systems used to remove iron, manganese or with very high chlorine concentrated feed waters.

## Lifetime Warranty on Resin Tank and Brine Tank

US Water Systems will provide a replacement resin tank or brine tank to any original equipment purchaser in possession of the Aquatrol water softener that fails for the Lifetime of the equipment after the date of purchase, provided that it is at all times operated in accordance with specifications and not subject to freezing.

## General Provisions

US Water Systems assumes no responsibility for consequential damage, labor or expense incurred as a result of a defect or for failure to meet the terms of these guarantees because of circumstances beyond our control. Installation workmanship failure is not covered under warranty. Damage caused by environmental conditions such as, lightning strikes, humidity or heat will not be covered under warranty.

These warranties are in lieu of all other warranties expressed or implied, and we do not authorize any person to assume for us any other obligation on the sale of this water conditioner. No responsibility is assumed for delays or failure to meet these warranties caused by strike, government regulations or other circumstances beyond the control of *US WATER SYSTEMS, INC.*

TO OBTAIN WARRANTY SERVICE, CALL OR WRITE: *US WATER SYSTEMS, INC. 1209 COUNTRY CLUB ROAD INDIANAPOLIS, IN 46234 (317) 271-8600.* ANY IMPLIED WARRANTIES OF FITNESS OR MERCHANTABILITY ARE LIMITED TO THE TERMS OF THIS EXPRESSED WARRANTY AND THERE ARE NO WARRANTIES WHICH EXTEND BEYOND THOSE HEREIN. *US WATER* SHALL NOT BE LIABLE FOR ANY INCIDENTAL OR CONSEQUENTIAL DAMAGES.

SOME STATES DO NOT ALLOW THE EXCLUSION OR LIMITATIONS OF INCIDENTAL OR CONSEQUENTIAL DAMAGES SO THE ABOVE LIMITATION MAY NOT APPLY TO YOU. THIS WARRANTY GIVES YOU SPECIFIC LEGAL RIGHTS, AND YOU MAY ALSO HAVE OTHER RIGHTS WHICH VARY FROM STATE TO STATE. THIS WARRANTY MAY BE TRANSFERRED TO A SUBSEQUENT OWNER WITH WRITTEN APPROVAL OF *US WATER* AND PAYMENT OF STANDARD TRANSFER FEE.

**Aquatrol** is a product of US Water Systems.

