

USWater
systems.com

US Water Systems All American Reverse Osmosis System

200-AARO-XXXX | 200-AARO-XXXX-P | 200-AARO-LIV-XXXX | 200-AARO-LIV-XXXX-P



 **ALL AMERICAN**
REVERSE OSMOSIS SYSTEM

Table of Contents

Parts Check List	3
Parts Overview	5
Tools Needed	6
Quick Connect Fittings	7
How To Make a Connection	7
Disconnecting	8
Installation Location	9
Installation	10
Faucet Installation	10
Feed Water Angle Stop Valve and Tubing Installation	11
Drain Saddle Installation	13
Tank Installation	14
Initial Tubing Connections	15
RO Unit Installation	15
Final Tubing Connections	15
Ice Maker Hookup (Optional)	17
System Start Up	18
Prior to Start Up	18
Flushing System and Checking Operation	18
Air Purging	18
Maintenance	20
Sanitizing Filter Change Instructions	21
Flushing System and Checking Operation	22
Air Purging	22
Why the Regular Use of Sani-System is Important	23
Ice Maker Kit Installation	24
Ice Maker Flow Diagram	25
Standard Flow Diagram	26
Permeate Pump Flow Diagram	27
Livation Flow Diagram	28
Livation Permeate Pump Flow Diagram	29
Warranty	30

Parts Check List

- RO Module

- Tubing Bundle 

- Filter Wrench 

- 1/4" Drain Saddle 

- Tank Valve 

- Angle Stop Feed Valve 

- Tank and Side Mount Tank Stand 

- Faucet and Mounting Kit 

- Faucet Connector 

- Pre and Post Filters + Membrane (Pre-Installed)



- Sanitizing Packet and Syringe



- Teflon Tape

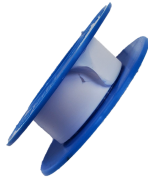

- TDS Meter



- Livation Membrane (Included with Alkaline System)



Parts Overview

- **Pre-Filter (Sediment Filter)** - Removes larger particles such as sand, silt, rust and scale.
- **Pre-Filter (Activated Carbon Filters)** - Removes chlorine and chloramine in the feed water to protect the reverse osmosis membrane.
- **Reverse Osmosis Membrane** - Reduces *dissolved* minerals, metals and salts. During the process, harmful compounds are separated by the membrane and the reject water goes to waste (drain).
- **Post-Filter** - Provides a final "polish" and removes foul tastes and odors to provide great tasting drinking water.
- **RO Module** - Housings hold the pre-filters and membrane while the bracket is provided to mount the system, typically below a sink.
- **Storage Tank** - Holds filtered water that is ready for use.
- **Automatic Shut-Off Valve (ASO)** - Senses when the storage tank is full and closes the water supply to conserve water. (Not used in a permeate pump system)
- **Permeate Pump** - Used to pressurize the tank and distribution system. This pump is operated by the drain water. The permeate pump will dramatically increase the faucet pressure. (A permeate pump system will not have an ASO valve.)
- **Faucet** - Used to dispense RO produced water when needed.
- **Feed Water Angle Stop Valve** - Connected to the cold water line to supply water to the RO system.
- **1/4" Waste Water Saddle Valve** - Connected to the drain to remove reject water from the RO system.
- **Tubing** - Supplies feed and reject water.
- **Fittings** - Used for necessary hose connections.

Tools Needed

The following tools may be necessary depending on each particular installation:

- 3/8 Drill and 1/4" drill bit



- Faucet Drill Bit - 1"



- Phillips head and flat blade screwdrivers



- Adjustable wrench



- Teflon tape

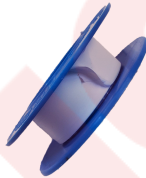

- Plastic Tube Cutter



Quick Connect Fittings

Many RO systems utilize quick connect fittings. These user-friendly fittings provide superior performance and are provided with this system. Proper use of these push-in fittings is shown below. Along with these fittings, all tubing selected must be of high quality and must be cut with a plastic tube cutter or sharp razor with a clean, square cut.

How To Make a Connection

1. **Cut the Tube Square** - It is essential that the outside diameter be free from score marks and that burrs and sharp edges be removed before inserting the tube into the fitting. For soft, thin walled tubing, we recommend the use of tube inserts.



2. **Insert Tube** - The fittings will grip before a seal is formed. Ensure the tubing is pushed fully into the tube stop.



3. **Push up to the Tube Stop** - Push the tubing into the fitting, up to the tube stop. The collet (gripper) has stainless steel teeth which hold the tubing firmly in position while the O-ring provides a permanent, leak proof seal.



4. **Pull to Check Secure** - Pull on the tubing to check that it is secure. It is a good practice to test the system prior to leaving the site and/or before use.



Disconnecting

Push in Collet and Remove Tubing - To disconnect, ensure the system is depressurized before removing the tube, Push in the collet squarely against the face of the fitting. With the collet held in this position, the tube can be removed. The fitting can be re-used.



Should a leak occur at a fitting, the cause is generally defective tubing. To fix a leak, relieve pressure, release tubing, cut off at least 1/4" from the end (square cut), reattach the tubing, and confirm the connection is leak free. Each time a new connection is made, it is advisable to cut off 1/4" from the end of the tubing using these fittings.

Installation Location

The RO system may be installed under a sink, in a basement, or other location depending on available space. Do not install unit where temperatures fall below freezing. Otherwise, damage will occur. Connection to an ice maker should also be considered for optimum performance.

- **Faucet** - Should be placed near the sink where drinking / cooking water is normally required. A 2" flat surface is required to mount the faucet if an existing hole for a second faucet is not available. The thickness of the mounting surface should not exceed 1-1/4"
- **Storage Tank** - May be placed where it is convenient within ten (10) feet of the RO module. Under the sink or in a nearby cabinet are excellent choices. Full tanks may weigh more than thirty pounds so a sturdy shelf is required.
- **RO Module** - May be mounted on either side of the sink, in a cabinet, or a heated basement with nearby access to a potable, cold water line and a sanitary drain.
- **Feed Water Connection** - Accomplished with an angle stop feed water valve. This valve will be installed in the cold water line between the sink cold water shutoff valve and the sink faucet tubing. Connect to a potable, cold water supply line only

NOTE: Softened water is preferred since it will extend the life of your RO membrane.

- **Drain Connection** - Accomplished using a waste water saddle valve which is designed to fit around a standard 1-1/2" OD drain pipe. The drain saddle valve should always be installed above (before) the trap and on the vertical or horizontal tailpiece. Do not install the drain saddle valve near a garbage disposal; otherwise, plugging of the waste water line may occur. If discharging into a utility sink or standpipe, an air gap may be needed. (Air gaps must be 1" or greater above the floor or pipe rim).

NOTE: Plumbing codes may require the use of air gaps. Check with your local municipality.

Do not connect the RO system drain line to the dishwasher drain line. Back pressure in the line may cause the air gap to over flow.

Installation

Faucet Installation

1. If the sink has a sprayer, it may be disconnected for faucet installation. A pipe cap or plug will be necessary to seal the sprayer connection. To make the faucet mounting hole (if sprayer or second hole is not used), check below the surface to ensure the drill does not interfere with anything. Drill a 1" hole for the faucet to be mounted in. Be sure to use a drill bit compatible with your surface. Clean up any sharp edges or burrs once the hole is drilled. The faucet should be positioned so it empties into the sink and the spout swivels freely for convenience. If the sink has a hole that can accommodate the RO faucet, no drilling is required. Proceed with mounting the faucet.
2. Remove the faucet from the packaging and remove the tightening nut from the faucet stem.



3. Install the faucet by inserting the faucet stem into the previously drilled hole. Make sure the rubber gasket is flush with the sink and seated properly.



4. Install the tightening nut onto the faucet stem underneath the sink. Assistance may be needed to hold the faucet in place while the nut is tightened.



5. Now push the blue tube into the faucet connector. Leave the other end of the blue tube unconnected for now. It will be connected later in the installation.

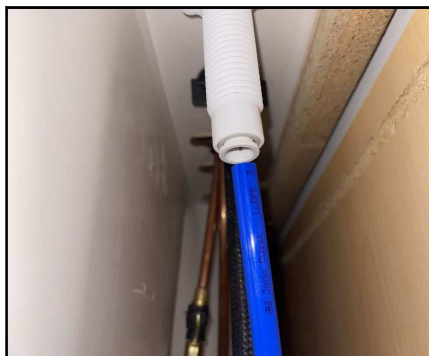

Feed Water Angle Stop Valve and Tubing Installation

1. To install the angle stop valve, turn off the cold water supply valve for the sink faucet. Open the sink faucet cold water and relieve the pressure.

2. Remove the sink faucet "whip hose" or tubing from the shutoff valve. There will be residual water spilled when this tube is removed. Be sure to have a towel to dry the water that is spilled. Now install the angle stop valve on the sink faucet shutoff valve and tighten it. Use two wrenches to hold the valve while tightening. Don't worry about the angle stop valve position because it will swivel and can be positioned later.



3. Install the whip hose or tubing on the angle stop valve and tighten.



4. Be sure the blue handle on the angle stop valve is in the closed position (as pictured). Now open the sink shutoff valve and check the angle stop connections for leaks. If there are leaks, repair them now. If there are no leaks, connect the orange tubing to the angle stop valve. Leave the other end of this tubing unconnected for now. It will be connected later in the installation.

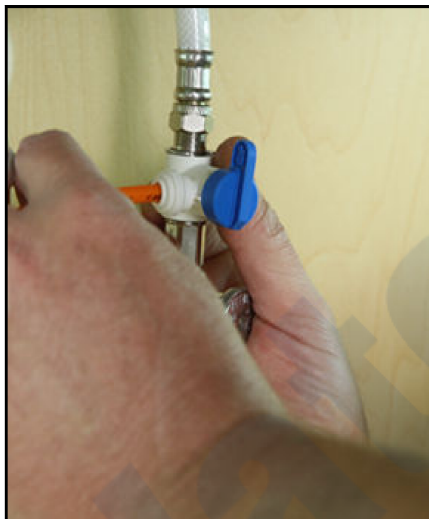

Drain Saddle Installation

Prior to Drain saddle installation, it is important to inspect the condition of drain pipes to make sure they are not thin and frail. Drain saddle valves are designed to be installed on standard 1-1/2" OD drain pipe. Install the drain saddle valve above the trap (between the sink and trap) and on the vertical or horizontal tailpiece. Never install a drain saddle valve close to the outlet of a garbage disposal or plugging of the RO drain line may result.

1. Position the port side of the drain saddle valve at the selected location and mark for the opening. Never position the opening at the bottom of the pipe. A side or top position is recommended. Install the rubber gasket on this half of the drain saddle. Be sure the gasket hole is lined up with the port hole.
2. Drill a 1/4" hole at the spot previously marked. Take care not to drill through both sides of the pipe.

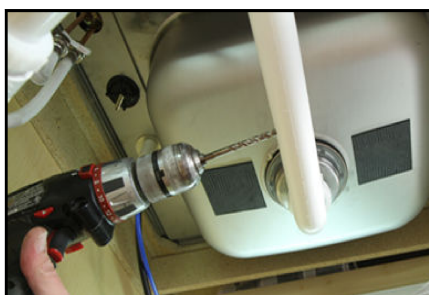

3. Position both halves of the drain saddle on the drain pipe so the quick connect opening lines up with the the previously drilled hole. A screwdriver may be used to keep the holes oriented during the tightening process.



4. Secure the drain saddle clamp on the drain pipe with the provided nuts and bolts. (Do not over tighten. Make sure there is equal space between saddle halves on each side.)

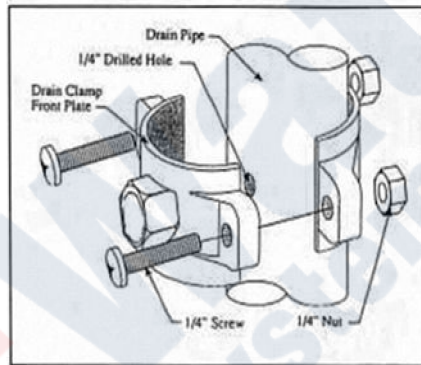

Drain saddle valve installation

5. Install the black drain line to the port on the drain saddle.



Tank Installation

1. Apply Teflon tape to the tank outlet threads. 3 - 4 wraps will be sufficient.
2. Install the tank valve by turning it clockwise. Tightening it hand tight is usually adequate but additional tightening may be required.
3. Once the valve is installed, connect the green 3/8" tubing to the tank valve. Leave the other end of the tubing loose. It will be connected later in the installation. **NOTE: Tanks are pre-pressurized at 7 psi. Prior to installation, check and add or release as required. Tanks should always maintain 7 psi**

Initial Tubing Connections

It may be desirable to leave the excess tubing when making the final connects. This will allow space to pull the unit out of the cabinet for filter changes without disconnecting all the tubing. If you want to secure the system and cut the tubing to fit, that is fine, but this may require that the system be removed for filter changes or the filters will have to be changed with the system in the cabinet, which can be difficult.

RO Unit Installation

The RO Unit is normally mounted to the sink cabinet sidewall, depending on where the supply tank is to be located. Generally, the unit is installed at the front of the cabinet and the tank at the rear.

To mount the unit, elevate it at least 2" off the floor, level it, and mark the location of the mounting holes needed. Drill holes for mounting screws then proceed to install the mounting screws. Allow the mounting bracket slots to slip over them.

NOTE: If the cabinet sidewalls are not solid, the unit may sit on the floor with screws installed to keep it against the cabinet in a vertical position. The system does not have to be secured to the wall but it is a good practice. If the system is not mounted to the cabinet wall and the tubing is not cut short, the module can be removed from the cabinet during filter changes.

Final Tubing Connections

With all components in place, complete final tubing connections using these guidelines

- Tubing should follow the contour of the cabinets.
- Cut tubing to desired length using square cuts or a proper cutting device.
- Ensure there are no sharp bends

Proceed with final tubing connections using the provided flow diagrams and the following procedures.

1. Connect the blue tubing from the faucet to the RO units post carbon filter outlet elbow fitting.

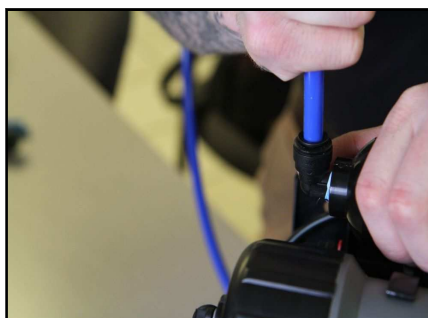

2. Be sure the storage tank shutoff valve is in the closed position. Use the supplied syringe and add 5ml of the supplied sanitizing solution to the green tank tubing attached to the storage tank. Connect the open end of the green tubing from the tank to the RO units post carbon filter inlet tee fitting. Leave the tank valve closed.



3. Connect the orange tubing from the angle stop supply valve to the RO unit at the sediment filter inlet fitting. When facing the unit, this is the far right sump.



Permeate Pump Installation - If the system is equipped with a permeate pump, clip the pump to the membrane housing using the supplied mounting bracket and make the connections to the pump using the label on the pump and the flow diagrams provided. The **BRINE OUT** connection will be made in the following step.

4. Connect the 1/4" black tubing from the RO unit to the drain saddle. If the system is equipped with a permeate pump, run a length of tubing from the "Brine Out" port on the permeate pump to the drain saddle connection.

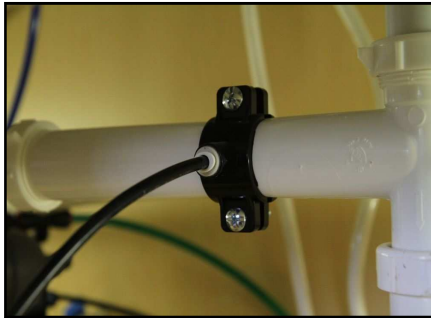

Ice Maker Hookup (Optional)

The RO drinking water system can be connected to any standard refrigerator ice maker or ice maker / water dispenser. 3/8" tubing must be used for ice maker connections. If your system is using 1/4" tubing for the tank and faucet, it will need to be changed to 3/8" tubing. (Do not connect to a commercial type bar ice maker.)

To complete this operation, connect a tee with shutoff valve into the faucet tubing (Blue Line) and route tubing to the refrigerator.

NOTE: Hooking up to an existing copper line is not recommended as RO water can cause the copper to leach into the water stream

Shut off the ice maker prior to turning off the existing tap water supply line to the refrigerator. Connect the RO system tubing to the ice maker inlet. Turn on the ice maker after the RO system has been flushed several times and the tank has a full supply of water. There are detailed instructions and a layout drawing on page 23.

NOTE: Before any service is performed on the RO system, turn off the ice maker valve and ice maker unit. Turn back on only after the RO tank has been flushed and is full of water.

System Start Up

Prior to Start Up

1. Check all connections and ensure they are secure.
2. Turn on the feed water valve and check for leaks. (Turn off and correct leaks if any occur)
3. Close the valve on the storage tank (The tank should be closed from the Final Tubing Connections) and open the faucet until a steady stream of water flows. Water will be flowing to the drain as well.
4. Once there is a steady stream of water coming from the faucet (about 1/8" in diameter), close the faucet and wait five minutes to see if any leaks result on the system. The initial water from the system may be discolored. This is normal.
NOTE: It is very important that there is a steady stream (not drips) of water coming from the faucet before it is closed. If not, there could be air trapped in the system and it will not fill the tank properly. This can waste a larger volume of water.
5. If there are no leaks, open the storage tank valve and allow the system to fill. Most systems will be full within 2 hours. The system is full when the water to the drain stops. Check for leaks with the system full and repair them accordingly.

CAUTION: Ensure that the system is not being fed with water above 75 PSI or damage to the system could occur.

Flushing System and Checking Operation

To make sure the RO system is operating correctly, follow these simple procedures:

1. Open the faucet handle and allow the tank to completely drain. (Water will be discolored and will have suds from the sanitizing solution)
2. Close faucet and re-fill the system.
3. Allow system to process water for approximately 2-3 hours. The tank will be practically full at this point.
4. Open the faucet again and allow the tank to empty for a second time. Do not use this water.
5. Wait another 2-3 hours to allow tank to re-fill.

Air Purging

If the tank does not fill, the tank tubing may have air in it. Typically the standard startup procedure will be sufficient but in some cases, due to the water temperature and pressure, additional air bleeding must be performed. The following procedure will help bleed air from the system.

1. Close the tank valve and the feed water valve and open the faucet to relieve the pressure on the system.
2. Remove the tank tubing from the tank valve and hold it over a bucket or pan.
3. Open the feed water valve and the faucet.
4. Allow the system to run until there is a stream of water coming from the tank tubing.
5. Once there is a steady stream coming from the tank tubing, push it back into the tank valve. Be sure to push it in the tank valve completely or a leak could occur.
6. Turn the tank valve on and allow water to run until there is a steady stream coming from the faucet. Then shut the faucet and allow the tank to fill.

NOTE: If no objectionable tastes are noticed after a second tank draining, RO processed water is ready for use. Otherwise, drain the tank and re-fill for a third time.

At this point, the supply line to an ice maker connection (optional) may be opened.

Maintenance

The RO system contains filters and membranes which must be replaced periodically for proper operation.

Replacement Part	Frequency
551-USWS-2509-05-OR (First Sump)	Every 6-12 Months
507-USWCB-2509-OR (Second Sump)	Every 6-12 Months
507-USWCB-2509-CL-OR (Third Sump)	Every 6-12 Months
255-208338 (50 GPD RO Membrane)	Every 3-5 Years
255-208340 (100 GPD RO Membrane)	Every 3-5 Years
530-INLRO-14-B (Carbon Post Filter)	Every 6-12 Months

NOTE: Filter change frequencies may be amended, depending on source water conditions.

Sanitizing Filter Change Instructions

1. Turn off the feed water to the system and shut off the ice maker power and water supply valve (if applicable).
2. Turn on the faucet to relieve any pressure on the system and make sure water has stopped flowing out of the faucet.
3. Remove the membrane and all the lower vertical sump filters. The post carbon filter can be left in place at this time. Use rubber gloves and store the membrane in water or a Ziploc bag to prevent damage or discard the membrane if it is being replaced.
4. Use the included plastic syringe to collect 5 ml of Sani-System solution from the packet and set aside. Pour the remainder of the packet of Sani-System directly into the sediment filter housing (where the orange inlet feed line attaches). Reattach all filter housings and membrane caps. Do not install the filters at this time. Remove the tube that connects to the storage tank from the RO module and invert it to remove the water from the tube. Inject all of the Sani-System solution from the plastic syringe into the line. Reattach the tank tube. Make sure the RO water faucet is closed and turn on the water supply.
5. Allow the system to fill with water. The time will vary depending on the water pressure. However, the system should be full within 5 - 10 minutes without the filters or membrane. Allow the system to rest for 10 minutes. Open the faucet and allow it to drain for 10 minutes after which, close the faucet. Allow the system to fill and rest for another 10 minutes. Open the faucet again and allow the system to flush for another 10 minutes. Shut off the inlet supply and open the faucet to depressurize the system. Remove the sumps and install the filters and membrane.
6. The white fiber-type filter is installed in the cap for the Inlet (sediment) filter sump. Lubricate the O-ring at the top of the sump and the O-rings on the filter with a small amount of silicone. Insert the filter into the sump cap. Install the filter sump, tighten the filter sump hand tight then, using a filter wrench, tighten an additional 1/4 turn. Do not over tighten.
7. The carbon block filters are installed into the next two sumps. The white capped carbon block will go in the middle sump. The green capped (Chloramine) carbon block will go in the last sump. Lubricate the O-ring at the top of each sump and the O-rings on the filters with a small amount of silicone. Insert the filters into the filter housing caps then install the filter sumps. Tighten the filter sumps hand tight then, using the filter wrench, turn an additional 1/4 turn. Do not over tighten.
8. The inline filter is installed on the top of the membrane housing. The fittings in each end of the old post filter must be removed and wrapped with 3-4 layers of 1/2" Teflon tape after having removed the old layer of Teflon tape. When looking at the threaded side of the fitting, wrap clockwise to ensure a proper seal. The tee fitting will screw into the inlet side of the new filter while the elbow fitting will screw into the outlet side. Re-install the tubing and make sure everything is sealed.

9. Turn on the feed water valve and check for leaks. Turn off the valve and correct leaks if any occur.
10. Close the valve on the storage tank and open the faucet until a steady stream of water flows. Water will be flowing to the drain as well. The initial water from the system may be discolored. This is normal.
11. Once there is a steady stream of water coming from the faucet (about 1/8" in diameter), close the faucet and wait five minutes to see if any leaks occur through the system.
NOTE: It is very important that there is a steady stream (not drips) of water coming from the faucet before it is closed. If not, there could be air trapped in the system and it will not fill the tank properly. This can waste a larger volume of water.
12. If there are no leaks, open the storage tank valve and allow the system to fill. Most systems will be full within 2 hours. The system is full when the water to the drain stops. Check for leaks with the system full and repair them accordingly.

Flushing System and Checking Operation

To make sure the RO system is operating correctly, follow these simple procedures:

1. Open the faucet handle and allow the tank to completely drain. (Water will be discolored and will have suds from the sanitizing solution)
2. Close faucet and re-fill the system.
3. Allow system to process water for approximately 2-3 hours. The tank will be practically full at this point.
4. Open the faucet again and allow the tank to empty for a second time. Do not use this water.
5. Wait another 2-3 hours to allow tank to re-fill.

Air Purging

If the tank does not fill, the tank tubing may have air in it. Typically the standard startup procedure will be sufficient but in some cases, due to the water temperature and pressure, additional air bleeding must be performed. The following procedure will help bleed air from the system.

1. Close the tank valve and the feed water valve and open the faucet to relieve the pressure on the system.
2. Remove the tank tubing from the tank valve and hold it over a bucket or pan.
3. Open the feed water valve and the faucet.
4. Allow the system to run until there is a stream of water coming from the tank tubing.
5. Once there is a steady stream coming from the tank tubing, push it back into the tank valve. Be sure to push it in the tank valve completely or a leak could occur.
6. Turn the tank valve on and allow water to run until there is a steady stream coming from the faucet. Then shut the faucet and allow the tank to fill.

NOTE: If no objectionable tastes are noticed after a second tank draining, RO processed water is ready for use. Otherwise, drain the tank and re-fill for a third time.

At this point, the supply line to an ice maker connection (optional) may be opened.

Why the Regular Use of Sani-System is Important

A reverse osmosis system should be sanitized regularly to maintain quality service levels. If the system is not properly maintained, bacteria can begin to grow and multiply wherever the water sits, including on the inside surfaces of tanks and hoses. Filling the system with impure water can also be a cause but, over time, bacteria grows - even in chlorinated water. When water sits in a tank or hose, chlorine levels drop, reducing its chemical ability to prevent bacterial growth. Filters can also filter out chlorine, making the water more susceptible to bacterial growth. In addition, system equipment such as hoses, filters, and canisters can harbor and help to support bacterial growth.

Sani-System is the only EPA & NSF approved sanitizer for use in reverse osmosis units. It is proven to kill 99.9% of harmful bacteria without the use of chlorine, oxidizers, or acids that can harm system parts. Sani-System maintains the performance of your reverse osmosis system and restores it to peak efficiency.

Ice Maker Kit Installation

1. Cut the 3/8" line that goes to the faucet and insert the 3/8" tee fitting.
2. Attach the 3/8" tubing that came with the kit to the open port on the tee.
3. Cut this tube about 2" after the 3/8" tee. Insert the shut off valve.
4. Attach the remaining 3/8" tubing to the refrigerator / ice maker close to the water inlet solenoid.
5. Now run the 3/8" tubing to the refrigerator / ice maker close to the water inlet solenoid.
6. Once the tubing is routed to the refrigerator / ice maker, use the 3/8" to 1/4" adapter to the existing 1/4" tubing on the refrigerator / ice maker or use the 7/16" x 3/8" water inlet solenoid adapter. If the solenoid adapter is used, remove the 1/4" existing line nut and sleeve, then screw the adapter to the water inlet solenoid. No sealant or Teflon tape is required for solenoid adapter. It is a compression fitting. Tighten the fitting and insert the 3/8" tubing. Leave the ice maker off until the RO system is flushed and full.
7. When the RO system is full, turn on the ice maker shutoff valve and the ice maker shutoff level or switch.
8. Disregard the first two batches of ice. This will flush the internal tubing in the ice maker or refrigerator.
9. If there is a filter in the refrigerator or ice maker, be sure to bypass it or make sure it is changed annually with the RO system filter.

Ice Maker Flow Diagram

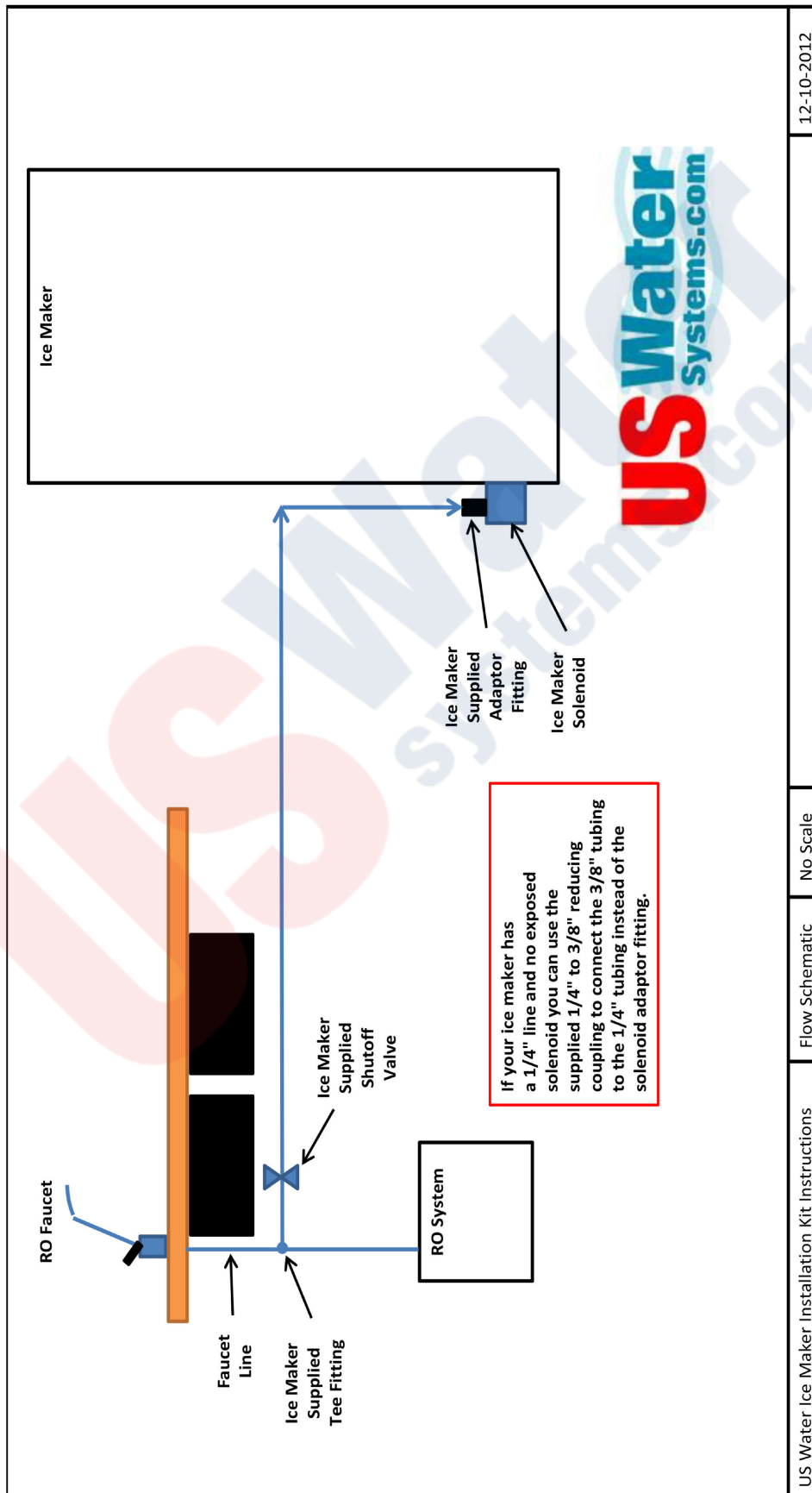

US Water Ice Maker Installation Kit Instructions	Flow Schematic	No Scale	12-10-2012
--	----------------	----------	------------

Standard Flow Diagram

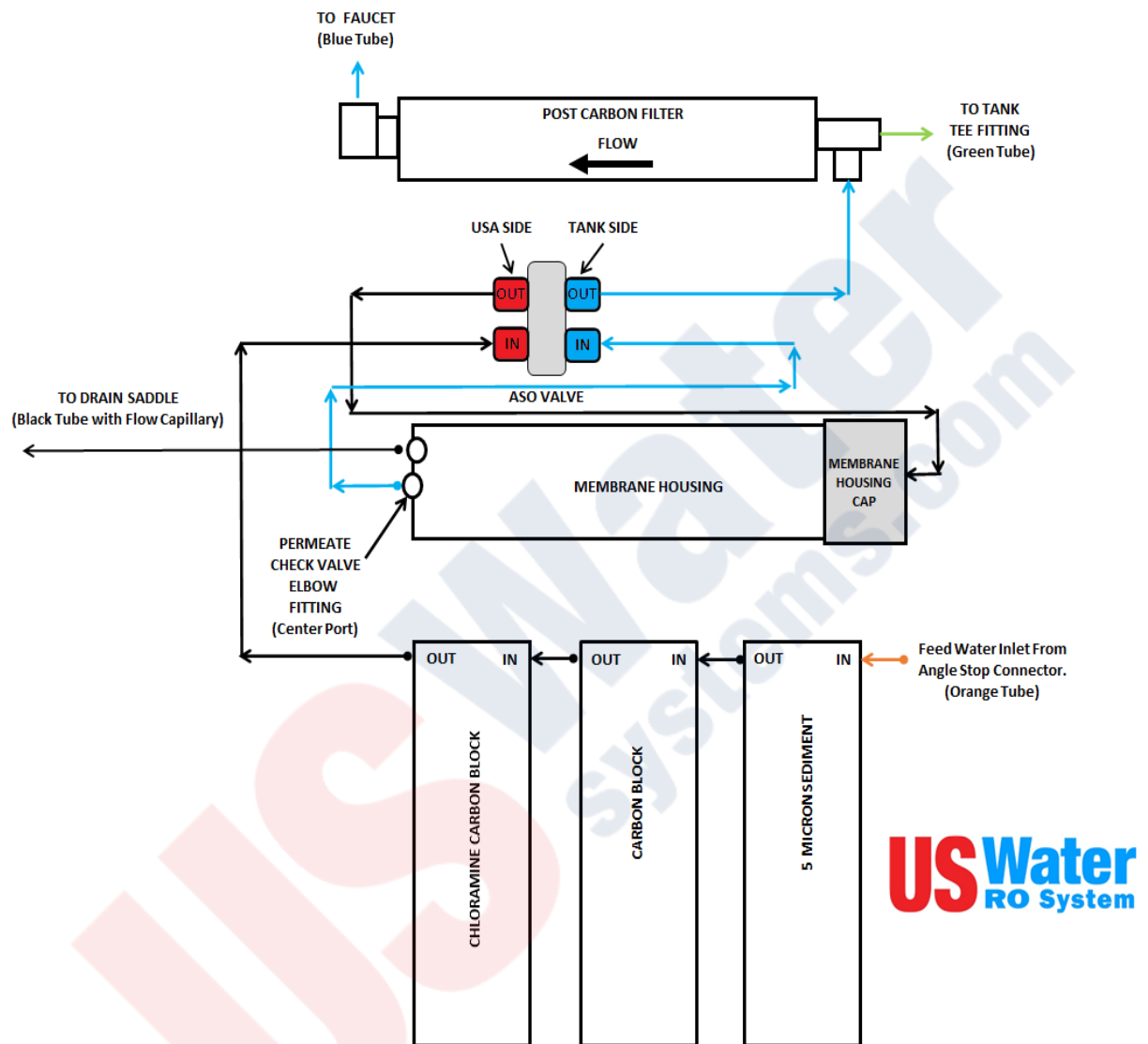

US Water Systems American Revolution RO System Flow Schematic	No Scale	Drawn by: C. Dietz	June 22, 2014
---	----------	--------------------	---------------

Permeate Pump Flow Diagram

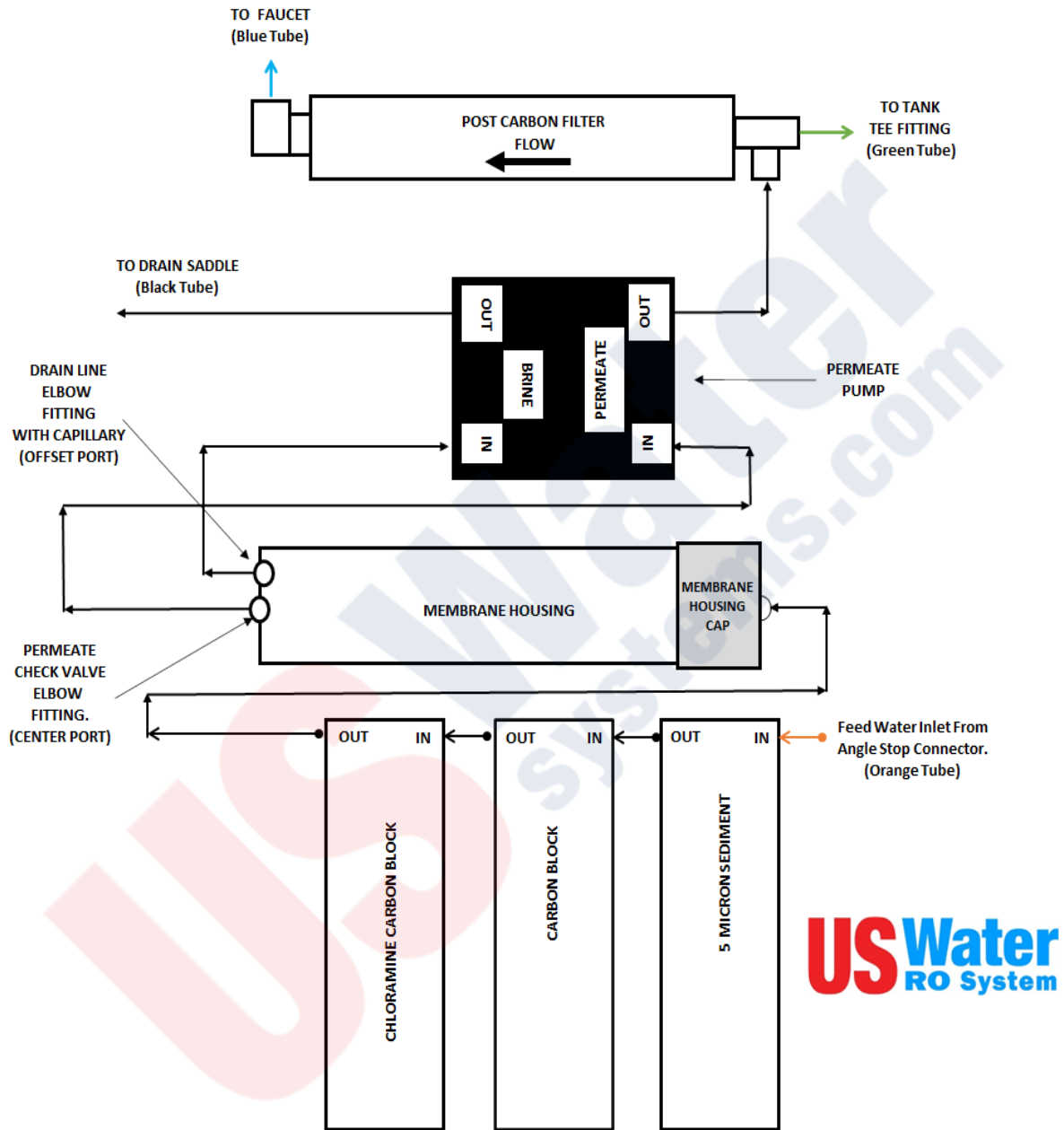

US Water Systems American Revolution RO System Flow Schematic	No Scale		Drawn by: C. Dietz June 22, 2014
---	----------	--	----------------------------------

Livation Flow Diagram

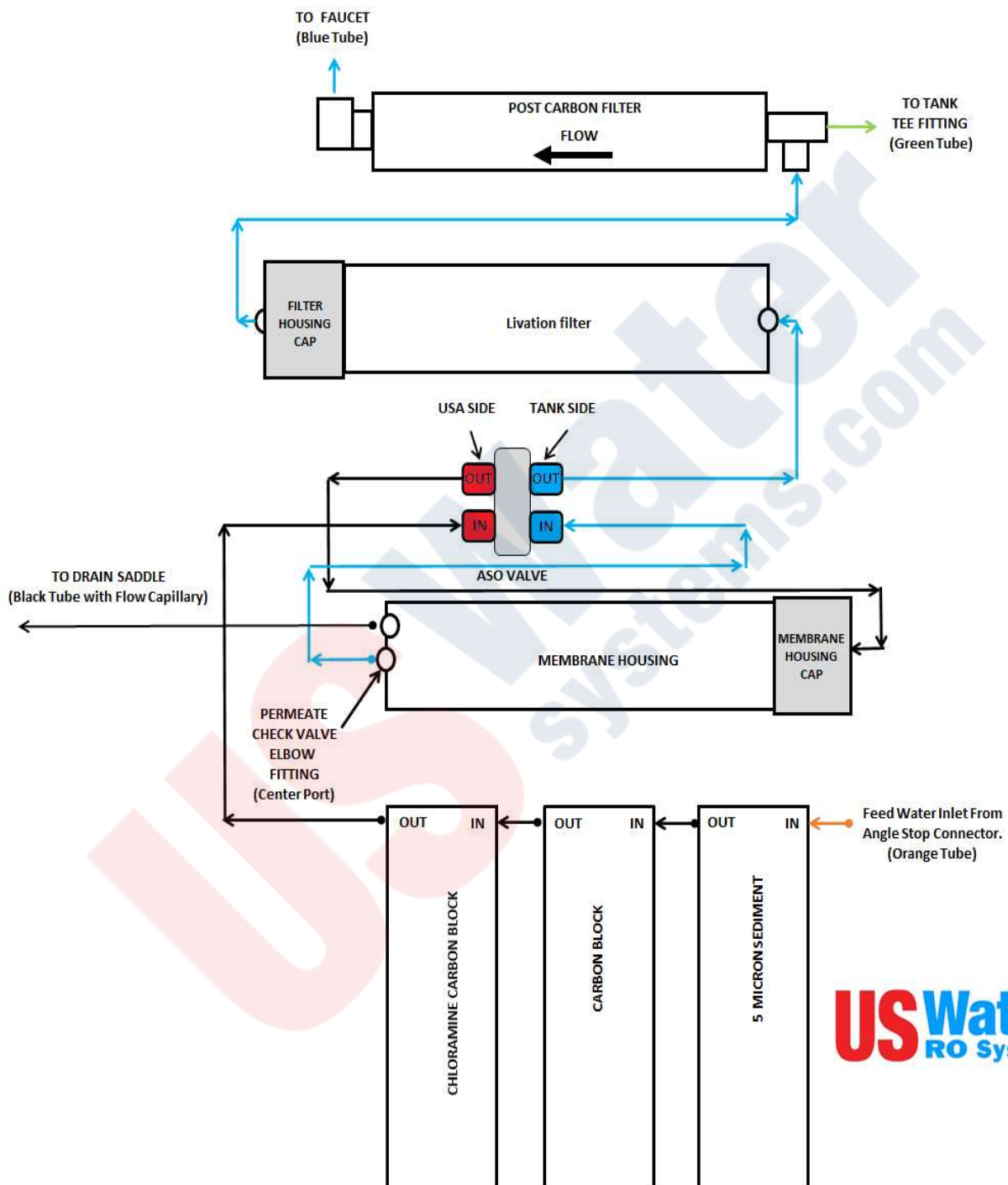

US Water Systems American Revolution RO System Flow Schematic | No Scale | Drawn by: C. Dietz | June 22, 2014

Livation Permeate Pump Flow Diagram

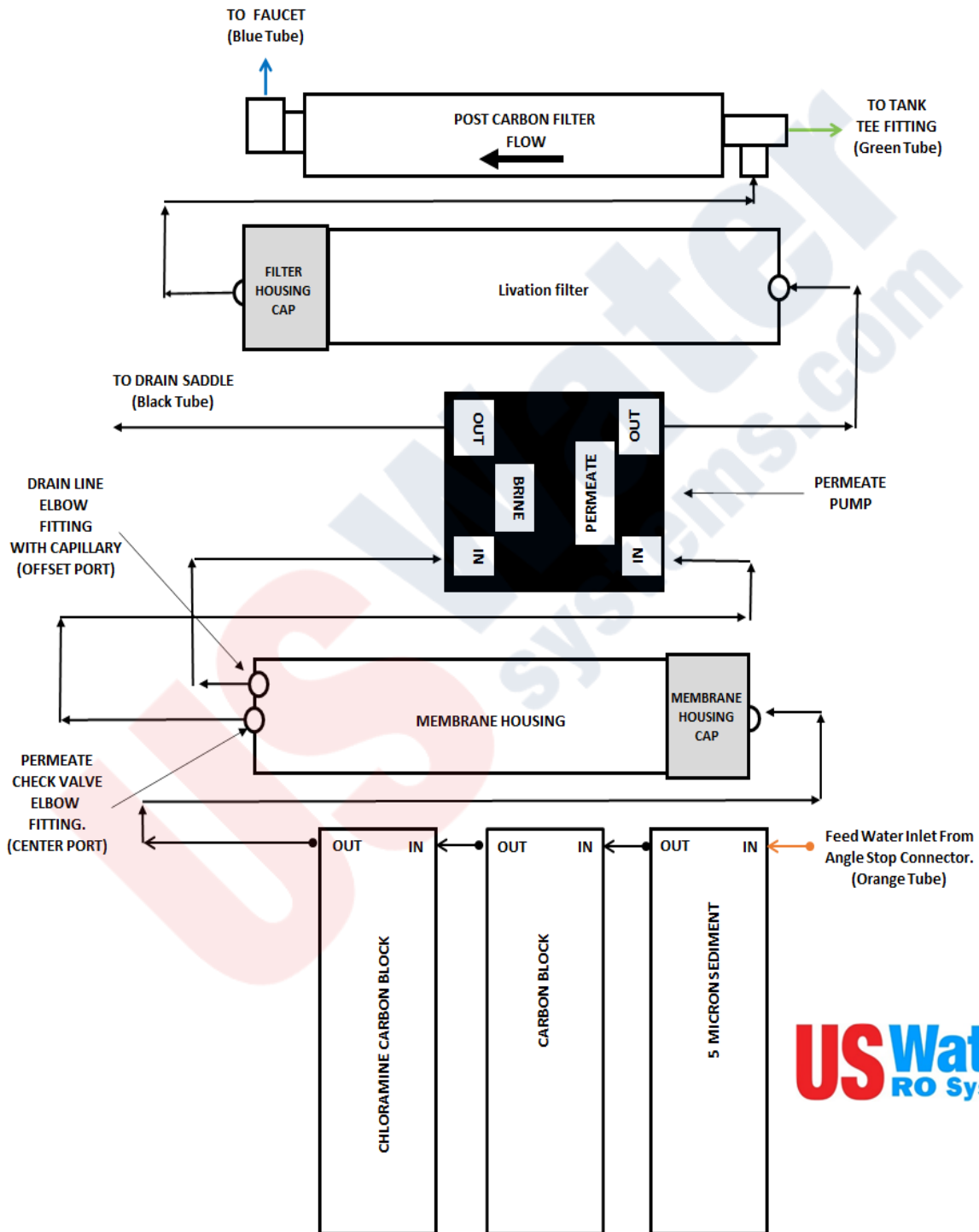

US Water Systems American Revolution RO System Flow Schematic	No Scale	Drawn by: C. Dietz	June 22, 2014
---	----------	--------------------	---------------

Warranty

This warranty cannot be transferred - it is extended only to the original purchaser or first user of the product in a residential application. By accepting this product, you agree to all of the warranty terms and limitations of liability described below. Important Warning: Carefully read the Installation & Operating Instructions Manual to avoid serious personal injury and property HAZARDS and to ensure safe and proper care of this product.

Model Numbers Covered: All AARO Models

This warranty covers the All-American Reverse Osmosis System, if you are the original owner of this system and purchased it for single family home use - subject to all of the conditions, limitations and exclusions listed below. Purchasers who buy this system for other purposes, and other component parts are subject to more limited warranties and you should read all of the terms included in this form to make sure you understand your warranty.

What is covered by this warranty? - US Water Systems, Inc. warrants that at the time of manufacture, the water treatment equipment shall be free from defects in material and workmanship as follows:

Filter Housings, Membrane Housing, Brackets, Tanks, Tubing, and Fittings are covered for five (5) years from the date of purchase, not the date of installation.

*** This warranty does not include filters or membranes.**

Additional Terms & Conditions - US Water Systems, Inc. will, at its option, either make repairs to correct any defect in material or workmanship or supply and ship either new or used replacement parts or products. US Water Systems, Inc. will not accept any claims for labor or other costs, including subsequent or consequential damages.

Additional Exclusions and Limitations - This warranty is non-transferable and does not cover any failure or problem unless it was caused solely by a defect in material or workmanship. In addition, this warranty shall not apply:

- If the water treatment equipment is not correctly installed, operated, repaired and maintained as described in the Installation & Operating Manual provided with the product.
- Defects caused as a direct result of the incoming water quality.
- To any failure or malfunction resulting from abuse (including freezing), improper or negligent handling, shipping (by anyone), etc..
- If the unit has not always been operated within the factory calibrated temperature limits, and at a water pressure not exceeding 75 psi, storage, use, operation, accident; or alteration, lightning, flooding or other environmental conditions;
- This warranty does not cover labor costs, shipping charges, service charges, delivery expenses, property damage, administrative

fees or any costs incurred by the purchaser in removing or reinstalling the water treatment equipment.

- The warranty does not cover any claims submitted to US WATER SYSTEMS, INC. more than 30 days after expiration of the applicable warranty, and does not apply unless prompt notice of any claim is given to an authorized US WATER SYSTEMS, INC. Dealer or to US WATER SYSTEMS, INC. or a designated contractor is provided access to the installation and to the water treatment equipment.

THESE WARRANTIES ARE GIVEN IN LIEU OF ALL OTHER EXPRESS WARRANTIES. NO US WATER SYSTEMS, INC. REPRESENTATIVE OR ANY OTHER PARTY IS AUTHORIZED TO MAKE ANY WARRANTY OTHER THAN THOSE EXPRESSLY CONTAINED IN THIS WARRANTY AGREEMENT.

Additional Warranty Limitations - ANY IMPLIED WARRANTIES THE PURCHASER MAY HAVE, INCLUDING THE IMPLIED WARRANTIES OF MERCHANTABILITY AND FITNESS FOR A PARTICULAR PURPOSE, SHALL NOT EXTEND BEYOND THE APPLICABLE TIME PERIODS SPECIFIED ABOVE. Some states do not allow limitations on how long an implied warranty lasts, so the above limitations may not apply to you.

Limitations of Remedies - The remedies contained in this warranty are the purchaser's exclusive remedies. In no circumstances will US WATER SYSTEMS, INC. or the seller of the product be liable for more than, and purchaser-user's remedies shall not exceed, the price paid for the product. In no case shall US WATER SYSTEMS, INC. or seller be liable for any special, incidental, contingent or consequential damages. Special, incidental, contingent and consequential damages for which US WATER SYSTEMS, INC. is not liable include, but are not limited to, inconvenience, loss or damage to property, consequential mold damage, loss of profits, loss of savings or revenue, loss of use of the products or any associated equipment, facilities, buildings or services, downtime, and the claims of third parties including customers. Some states do not allow the exclusion or the limitation of incidental or consequential damages, so the above limitations or exclusion may not apply to you.

What to do if you have a problem covered by this warranty - Any warranty coverage must be authorized by US WATER SYSTEMS, INC. Contact the person from whom you purchased the product, who must receive authorization from a US WATER SYSTEMS, INC. or Dealer. If your product is new and not used and you wish to return it, contact your US WATER SYSTEMS, INC. or Dealer.