

SOFTENER

MODEL NO. 140-39-900-S-4M

CAPACITY:

MIN. 720,000 grs. @ 10 lbs./cu.ft. (each tank)
 MAX. 900,000 grs. @ 15 lbs./cu.ft. (each tank)

FLOW RATE:

NORMAL 200 gpm. (each tank)
 PEAK 270 gpm. (each tank)
 BACKWASH 50 gpm. (each tank)

TANK SIZE: 42" x 72"

COMPOSITE

MEDIA:

RESIN 30 cu.ft. (each tank)
 GRAVEL 700 lbs. (each tank)

PIPE SIZE:

INLET 3"
 OUTLET 3"
 DRAIN 2"
 BRINE 1"
 METER 3"

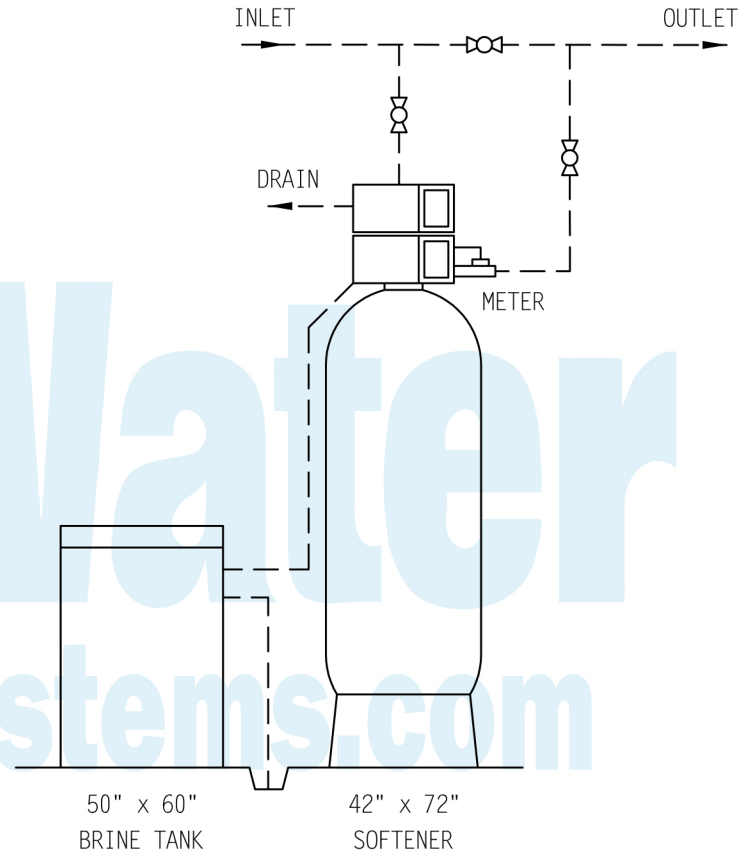

NOTE:
 ALL DASHED PIPE, VALVES,
 AND FITTINGS NOT PROVIDED
 BY US WATER SYSTEMS

BRINE TANK

TANK SIZE: 50" x 60"

POLYETHYLENE

CAPACITY:

500 gals.
 4500 lbs./salt

BRINE VALVE: 494

BRINE WELL: 5"

WEIGHT (APPROX)

TOTAL SHIPPING 3,405 lbs.

SPACE REQUIRED (APPROX)
 96"L x 50"W x 101"H

PEAK FLOWS ARE NOT
 RECOMMENDED FOR EXTENDED
 PERIODS OF TIME.

DO NOT SCALE DRAWING

THIS DRAWING IS ISSUED IN CONFIDENCE AND
 CANNOT BE REPRODUCED OR USED TO
 MANUFACTURE ANYTHING SHOWN OR REFERRED
 TO WITHOUT DIRECT WRITTEN PERMISSION FROM
 US WATER SYSTEMS

| | | |
|---|------------------------------------|---|
|  | | US WATER SYSTEMS 1209 COUNTRY CLUB RD INDIANAPOLIS, IN 46234 1-800-608-8792 |
| GENERAL ARRANGEMENT DWG. SOFTENER 900K SYSTEM 4-METER | | |
| DRAWN BY: M. CURTIS DATE: CHECKED BY: PAGE 1 OF 1 | DWG. NO. 140-39-900-S-4M | |