

2" SEDIMENT FILTER

MODEL NO. 140-31F-CSB-20

FLOW RATE:
 PEAK 125 GPM.
 BACKWASH 85 GPM.

TANK SIZE: 36" x 72"
 COMPOSITE

MEDIA:
 CHEMSORB 20 cu. ft.
 GRAVEL 500 lbs.

PIPE SIZE"
 INLET 2"
 OUTLET 2"
 DRAIN 2"

WEIGHT (APPROX)
 TOTAL SHIPPING 1950 lbs.

SPACE REQUIRED (APPROX)
 36" L x 36" W x 85" H

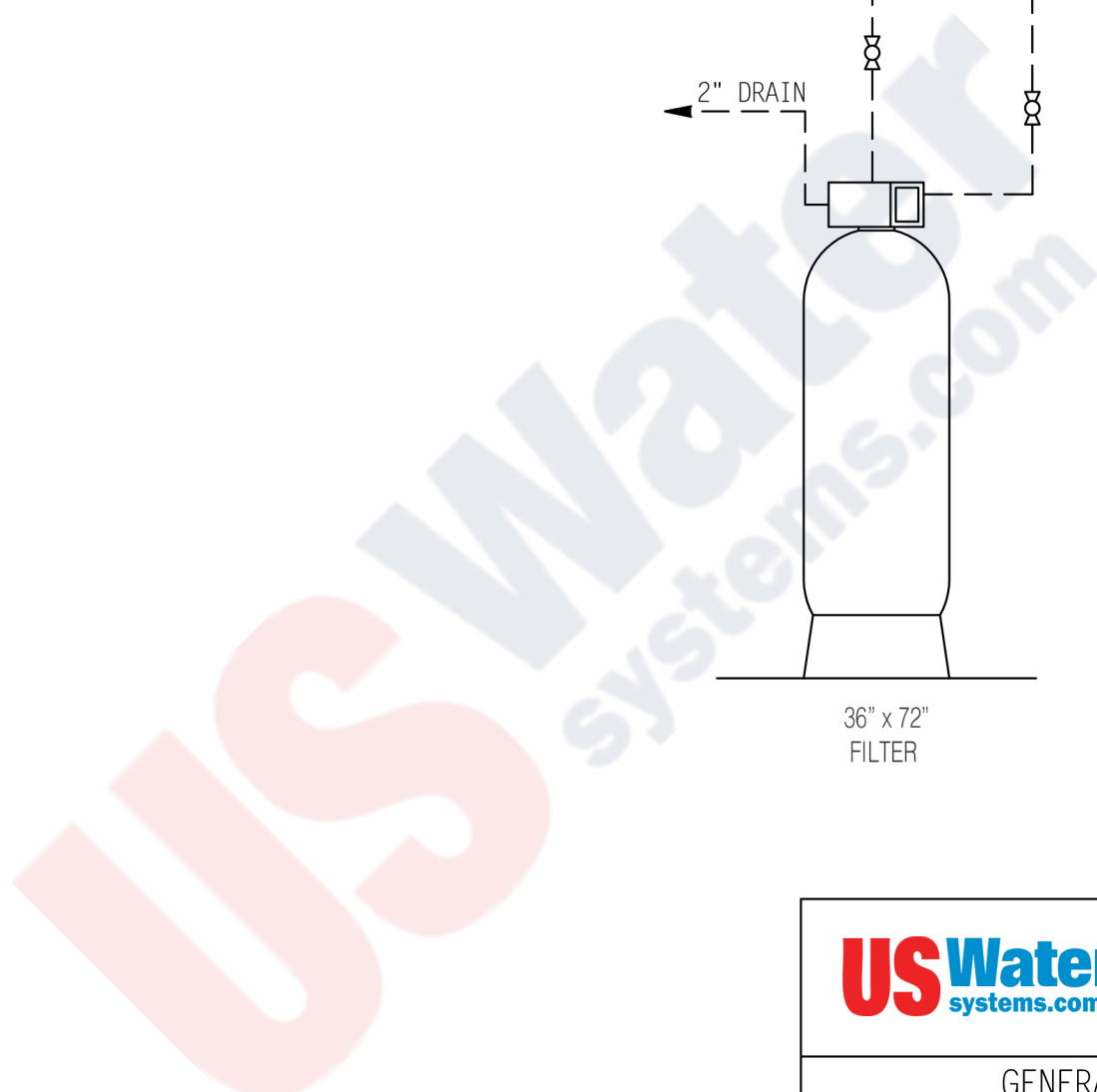
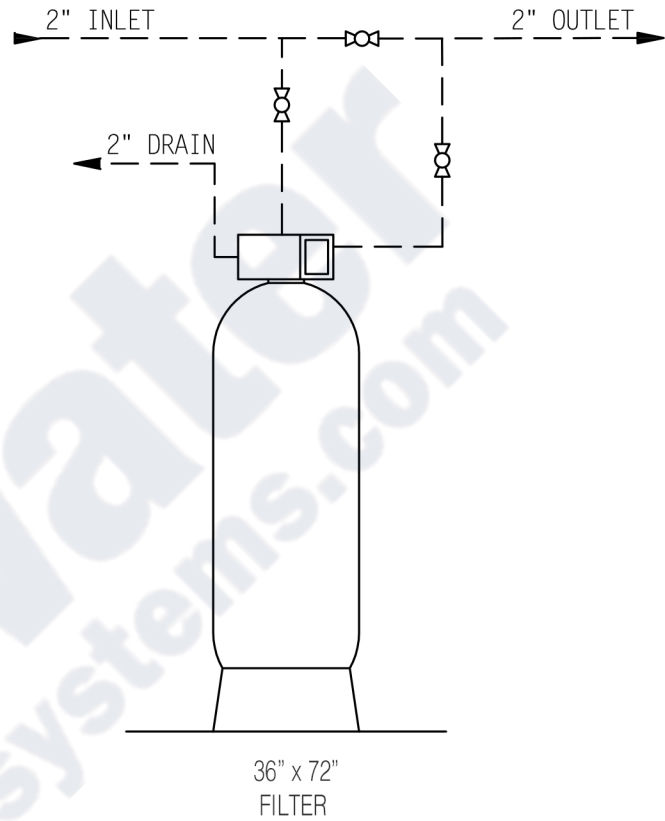

NOTE:
 ALL DASHED PIPE, VALVES,
 AND FITTINGS NOT PROVIDED
 BY US WATER SYSTEMS

DO NOT SCALE DRAWING

THIS DRAWING IS ISSUED IN CONFIDENCE AND CANNOT BE REPRODUCED OR USED TO MANUFACTURE ANYTHING SHOWN OR REFERRED TO WITHOUT DIRECT WRITTEN PERMISSION FROM US WATER SYSTEMS

| | | | |
|---|----------------------------------|--|--|
|  | | US Water Systems 1209 Country Club Road Indianapolis, IN 46234 1-800-608-8792 www.USWaterSystems.com | |
| GENERAL ARRANGEMENT DWG. FILTER SIMPLEX SYSTEM TIMELOCK | | | |
| DRAWN BY: DATE: CHECKED BY: PAGE 1 OF 1 | _____ _____ _____ _____ | DWG. NO. 140-31F-CSB-20 | |