



Installation and Operation Manual

BISTRO WOOD BURNING COOKSTOVE

(DB04815 model)

ENGLISH

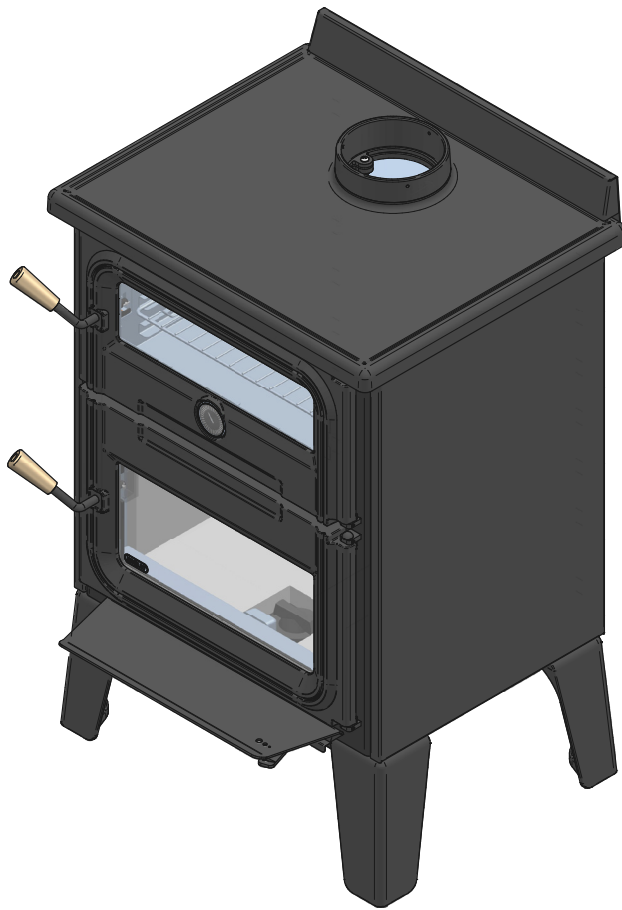

Security test made according to regulations ULC S627 and UL 1482 by an accredited laboratory.

CONTACT LOCAL BUILDING OR FIRE OFFICIALS ABOUT RESTRICTIONS AND INSTALLATION INSPECTION REQUIREMENTS IN LOCAL AREA.

READ THIS ENTIRE MANUAL BEFORE INSTALLATION AND USE OF THIS WOOD STOVE. FAILURE TO FOLLOW THESE INSTRUCTIONS COULD RESULT IN PROPERTY DAMAGE, BODILY INJURY OR EVEN DEATH.

U.S. ENVIRONMENTAL PROTECTION AGENCY: THIS UNIT IS NOT A CERTIFIED RESIDENTIAL WOOD HEATER. THE PRIMARY USE FOR THIS UNIT IS FOR COOKING OR BAKING.

READ AND KEEP THIS MANUAL FOR REFERENCE

THANK YOU FOR CHOOSING THIS WOOD BURNING COOKSTOVE.

If this cookstove is not installed properly, combustible materials near it may overheat and catch fire.

To reduce the risk of fire, follow the installation instructions in this manual.

As one of North America's largest and most respected wood stove and fireplace manufacturers, Stove Builder International takes pride in the quality and performance of all its products.

The following pages provide general advice on wood heating, detailed instructions for safe and effective installation, and guidance on how to get the best performance from this cookstove.

It is highly recommended that this cookstove be installed and serviced by professionals who are certified in the United States by NFI (National Fireplace Institute®) or in Canada by WETT (Wood Energy Technology Transfer) or in Quebec by APC (Association des Professionnels du Chauffage).

Contact local building or fire officials about restrictions and installation inspection requirements in your local area.

A building permit might be required for the installation of this cookstove and the chimney that it is connected to. It is also highly recommended to inform your home insurance company.

Please read this entire manual before installing and using this cookstove.

ONLINE WARRANTY REGISTRATION

If the unit requires repairs during the warranty period, proof of purchase must be provided. The purchase invoice must be kept. The date indicated on it establishes the warranty period. If it can not be provided, the warranty period will be determined by the date of manufacture of the product.

It is also highly recommended to register the warranty online at

<https://www.drolet.ca/en/warranty/warranty-registration/>

Registering the warranty will help to quickly find the information needed on the unit.

TABLE OF CONTENTS

CERTIFICATION PLATE	6
PART A - OPERATION AND MAINTENANCE	7
1. Safety Information	7
2. General information	9
2.1 Specifications	9
2.2 Cookstove Dimensions	10
3. Cookstove operation	12
3.1 Components use	12
3.2 Gas path.....	15
4. Combustibles	16
4.1 Tree Species	16
4.2 Log Length	17
4.3 Piece Size.....	17
4.4 Drying Time	17
5. Efficient wood combustion	18
5.1 General Advice.....	18
5.2 First Use	19
5.3 Lighting Fires	19
5.4 Combustion Cycles	20
5.5 Rekindling a Fire.....	21
5.6 Air Intake Control	21
6. Maintenance	23
6.1 Combustion Chamber.....	23
6.2 Removing ashes.....	23
6.3 Grills and cast iron cooking surface	24
6.4 Cleaning and Painting	24
6.5 Refractory Materials and Baffle.....	24
6.6 Glasses	25
6.7 Decorative Panels.....	31
6.8 Optional Fresh Air Intake Kit Installation	32
6.9 Air Tubes And Baffle Installation	33
6.10 Handles installation	34
6.11 Mobile Home Installation.....	35
6.12 Exhaust System	35

PART B - INSTALLATION.....37

7. General Information..... 37

7.1 Security37

7.2 Regulations Governing the Installation of the Cookstove38

7.3 Cookstove Positioning38

7.4 Location of the Certification Label38

8. Clearances to Combustible Material 39

8.1 Floor Protection42

8.2 Clearances Reduction to the Walls and the Ceiling43

8.3 Clearances for Shield Installation45

9. Evacuation System..... 47

9.1 General Information47

9.2 Suitable Chimneys.....47

9.3 Minimum Chimney Height49

9.4 Chimney Location.....49

10. Installing the Chimney Connector..... 51

10.1 Installation of Single Wall Chimney Connector51

10.2 Installation of Double wall Chimney Connector53

11. Combustion Air..... 54

11.1 Mobile home54

11.2 Conventional House55

12. Troubleshooting 56

13. Parts List 57

Bistro Cooking Stove Limited Lifetime Warranty60

Dealer:	
Installer:	
Phone Number:	
Serial Number:	

CERTIFICATION PLATE



REFER TO INTERTEK'S DIRECTORY OF BUILDING PRODUCTS FOR DETAILED INFORMATION
SE RÉFÉRER AU RÉPERTOIRE DES PRODUITS HOMOLOGUÉS D'INTERTEK POUR PLUS D'INFORMATION

STANDARDS / NORMES D'ESSAI:
Certified to/Certifié selon ULC S627
Certified to/Certifié selon UL 1482

LISTED SOLID FUEL BURNING
APPLIANCE

POÊLE À COMBUSTIBLE SOLIDE
HOMOLOGUÉ

MODEL / MODÈLE :

BISTRO

Intertek
June/Juin 2021

Control number: 4002461

Serial Number
No. de Série

1

Clearances to combustibles / Dégagements aux combustibles

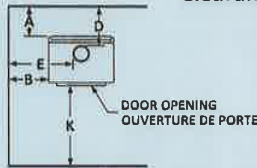

DOOR OPENING
OUVERTURE DE PORTE

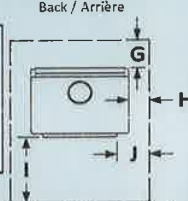
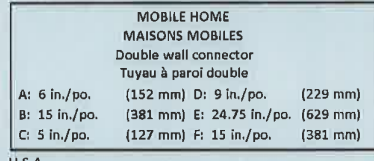
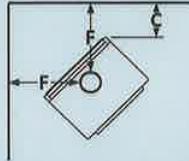

Back / Arrière

U.S.A.

CANADA		U.S.A.		CANADA		U.S.A.	
Single wall connector Tuyau à paroi simple	Double wall connector Tuyau à paroi double	Single wall connector Tuyau à paroi simple	Double wall connector Tuyau à paroi double	Protection de plancher/Floor protection	Protection de plancher/Floor protection	Protection de plancher/Floor protection	Protection de plancher/Floor protection
A: 15 in./po. (381 mm)	A: 6 in./po. (152 mm)	A: 15 in./po. (381 mm)	A: 6 in./po. (152 mm)	G: 8 in./po. (203 mm)	I: 16 in./po. (406 mm)		
B: 15 in./po. (381 mm)	B: 15 in./po. (381 mm)	B: 15 in./po. (381 mm)	B: 15 in./po. (381 mm)	H: 8 in./po. (203 mm)	J: 8 in./po. (203 mm)		
C: 7.5 in./po. (191 mm)	C: 5 in./po. (127 mm)	C: 7.5 in./po. (191 mm)	C: 5 in./po. (127 mm)	I: 18 in./po. (457 mm)	K: 36 in./po. (914 mm)		
D: 18 in./po. (457 mm)	D: 9 in./po. (229 mm)	D: 18 in./po. (457 mm)	D: 9 in./po. (229 mm)				
E: 25 in./po. (635 mm)	E: 24.75 in./po. (629 mm)	E: 25 in./po. (635 mm)	E: 24.75 in./po. (629 mm)				
F: 18 in./po. (457 mm)	F: 15 in./po. (381 mm)	F: 18 in./po. (457 mm)	F: 15 in./po. (381 mm)				

Floor-ceiling/plancher-plafond: 72 in./po. (183cm)

* See owner's manual for other clearances with lowered ceiling/
voir manuel d'installation pour autres dégagements avec plafond abaissé

PREVENT HOUSE FIRES

- Install and use only in accordance with the manufacturer's installation and operating instructions.
- Contact local building or fire officials about restrictions and installation inspection in your area.
- Use listed 152 mm / 6 in. diameter single or double wall connectors with prefabricated chimneys approved UL 103 HT (US) and ULC S629 (CAN) suitable for solid fuels or lined masonry chimneys.
- See local building code and manufacturer's instructions for precautions required for passing a chimney through a combustible wall or ceiling.
- Do not pass connector through combustible wall or ceiling.
- Do not connect this unit to a chimney serving another appliance.
- Use with wood only. Do not use other fuels.
- Operate only with door closed. Open door to feed the stove only.
- Do not obstruct the space underneath the stove.
- Do not use grate or elevate fire. Build fire directly on hearth.
- Do not overfire. If heater or chimney connector glows, you are overfiring.
- Inspect and clean chimney frequently. Under certain condition of use, creosote buildup may occur rapidly.
- Replace glass with ceramic type only.
- Install unit on a non-combustible material extending as shown above on this label.
- Suitable for mobile-home installation. Floor protection may vary from pedestal to legs version refer to owner's manual.
- Combustion air openings shall not be obstructed.
- This wood heater needs periodic inspection and repair for proper operation. Consult the owner's manual for further information. It is against US federal regulations to operate this wood heater in a manner inconsistent with the operating instructions in the owner's manual.

PRÉVENEZ LES INCENDIES

- Installer et utiliser conformément au manuel d'utilisation du fabricant.
- Contacter les autorités de votre localité ayant juridiction concernant les restrictions et inspections d'installation.
- Utiliser des tuyaux d'évacuation à parois simple ou double homologués d'un diamètre de 6 po. (152 mm) avec une cheminée préfabriquée approuvée UL 103 HT (US) et ULC S629 (CAN) pour utilisation au bois ou une cheminée de maçonnerie gainée.
- Voir les codes locaux et le manuel d'installation du fabricant pour le passage de la cheminée à travers un mur ou un plafond combustible.
- Ne pas traverser un plafond ou un mur combustible avec un tuyau d'évacuation.
- Ne pas raccorder cet appareil à une cheminée desservant un autre appareil.
- Brûler du bois seulement. Ne pas utiliser d'autres combustibles.
- Garder la porte fermée en tout temps. Ouvrir la porte que lors du chargement.
- Ne rien entreposer sous l'appareil.
- Ne pas utiliser de grilles ou de chenets pour surélever le feu. Préparer le feu directement sur l'âtre.
- Ne pas surchauffer. Si l'appareil ou le tuyau rougit, il y a surchauffe.
- Inspecter et nettoyer la cheminée fréquemment. Sous certaines conditions, l'accumulation de crésote peut être rapide.
- Remplacer la vitre seulement avec un verre de céramique.
- Installer l'appareil sur une plaque non combustible tel qu'indiqué sur l'étiquette.
- Poêle approuvé pour maison mobile. La protection de plancher peut varier entre la version piédestal et sur pattes. Voir le manuel d'instructions.
- Les entrées d'air servant à la combustion ne doivent pas être obstruées.
- Cet appareil de chauffage requiert des inspections et réparations périodiques. Consulter le manuel de l'utilisateur pour plus d'information. Opérer cet appareil de chauffage de façon inconsistante par rapport au manuel de l'utilisateur consiste en une violation de la loi fédérale (USA).

"U.S. ENVIRONMENTAL PROTECTION AGENCY This unit is not a certified residential wood heater. The primary use for this unit is for cooking or baking".

AGENCE DE PROTECTION DE L'ENVIRONNEMENT DES É.U. (EPA) Cette unité n'est pas un appareil de chauffage au bois résidentiel certifié. L'utilisation principale de cette unité concerne la cuisson."



WARNING: This product can expose you to carbon monoxide, which is known to the State of California to cause cancer, birth defects or other reproductive harm. (For more information go to www.p65warnings.ca.gov)



CAUTION

- HOT WHILE IN OPERATION.
- DO NOT TOUCH. KEEP CHILDREN, CLOTHING AND FURNITURE AWAY.
- CONTACT MAY CAUSE SKIN BURNS. SEE NAME-PLATE AND INSTRUCTIONS

ATTENTION

- CHAUD EN FONCTIONNEMENT.
- NE PAS TOUCHER. GARDER LES ENFANTS, LES VÊTEMENTS ET LES MEUBLES ÉLOIGNÉS.
- UN CONTACT AVEC LA PEAU PEUT OCCASIONNER DES BRÛLURES. VOIR LES INSTRUCTIONS.

Made in St-Augustin-de-Desmaures (Qc), Canada
12/05/2021 (# test)



Fabriqué à St-Augustin-de-Desmaures (Qc), Canada
12/05/2021 (# test)

27883

PART A - OPERATION AND MAINTENANCE

U.S. ENVIRONMENTAL PROTECTION AGENCY: THIS UNIT IS NOT A CERTIFIED RESIDENTIAL WOOD HEATER. THE PRIMARY USE FOR THIS UNIT IS FOR COOKING OR BAKING.

1. Safety Information

- Operate only with doors fully closed. If door is left partly open, gas and flame may be drawn out of the opening, creating risks from both fire and smoke.
- The cookstove is not designed to be used when the door is open. Open the door only to startup or to reload the stove.
- Don't leave unattended when the door is slightly open for startups. Always close the door after ignition.
- **HOT WHILE IN OPERATION, KEEP CHILDREN, CLOTHING AND FURNITURE AWAY. CONTACT MAY CAUSE SKIN BURNS. GLOVES MAY BE NEEDED FOR COOKSTOVE OPERATION.**
- Using the cookstove with cracked or broken components, such as glass, firebricks or baffle may produce an unsafe condition and may damage the cookstove.
- Open the air control fully before opening the combustion chamber door.
- Do not store fuel within cookstove minimum installation clearances.
- Do not store wood underneath the combustion chamber.
- Burn only seasoned natural firewood.
- Do not elevate the fire by using a grate.
- A smoke detector, a carbon monoxide detector and a fire extinguisher should be installed in the house. The location of the fire extinguisher should be known by all family members.
- Paint used on this appliance is not food grade (including the cast iron cooking surface). It is strongly not recommended to cook directly on the painted surfaces.
- Radiant heat coming from the stove glass can cause intense heat or burning sensations. It is recommended to cook on the cast iron cooking surface from the side of the appliance.
- During cooking, keep the oven door closed to keep a constant temperature.
- Make sure the ash drawer is in place when the cookstove is in use (when it gives off heat).

- **DO NOT USE CHEMICALS OR FLUIDS TO START THE FIRE.**
- **DO NOT BURN GARBAGE OR FLAMMABLE LIQUIDS SUCH AS GASOLINE, NAPHTHA, FUEL OIL, ENGINE OIL, KEROSENE, CHARCOAL LIGHTER FUEL, SIMILAR LIQUIDS, OR AEROSOLS TO START, REVIVE OR NEAR THE FIRE. KEEP ALL SUCH LIQUIDS WELL AWAY FROM THE HEATER WHILE IT IS IN USE.**
- This appliance should always be maintained and operated in accordance with these instructions.



WARNING: This product can expose you to chemicals including carbon monoxide, which is known to the State of California to cause cancer, birth defects or other reproductive harm. For more information go to www.P65warnings.ca.gov

2. General information

2.1 Specifications

Model	Bistro woodburning cookstove (DB04815)
Fuel Type	Dry Cordwood
Recommended log length	16" (406 mm)
Maximum log length	20" (508 mm) east-west orientation ¹
Flue outlet diameter	6 in (150 mm)
Chimney diameter	6 in (150 mm)
Type of chimney	UL 103 HT, ULC S629
Necessary flue draft	0,05" H ₂ O (12 Pa)
Alcove installation	Not approved
Mobile home installation ²	Approved
Shipping weight	575 lb (261 kg)
American standards (security)	UL 1482
Canadian standards (security)	ULC S627
Oven dimensions (WxDxH)	18" x 15-5/16" x 7-7/8" 457 mm x 177 mm x 381 mm

ENGLISH

¹ East-west orientation: longitudinal side of logs visible; north-south orientation: end of logs visible.

² Mobile home (Canada) or prefabricated home (USA): The US department of Housing and urban development describes "prefabricated homes" better known as "mobile homes" as follows; constructed buildings on fixed wheels and those transported on temporary wheels/axles installed on a permanent foundation. In Canada, a mobile home is a dwelling which the assembly of each component is done or mostly done before moving it to a location where it will be placed on foundations and connected to service facilities that meet the standards CAN/CSA-Z240 MH.

2.2 Cookstove Dimensions

ENGLISH

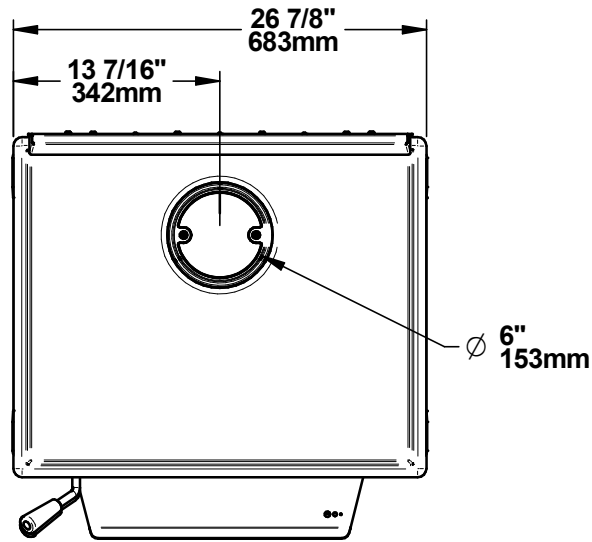

Figure 1: Top view

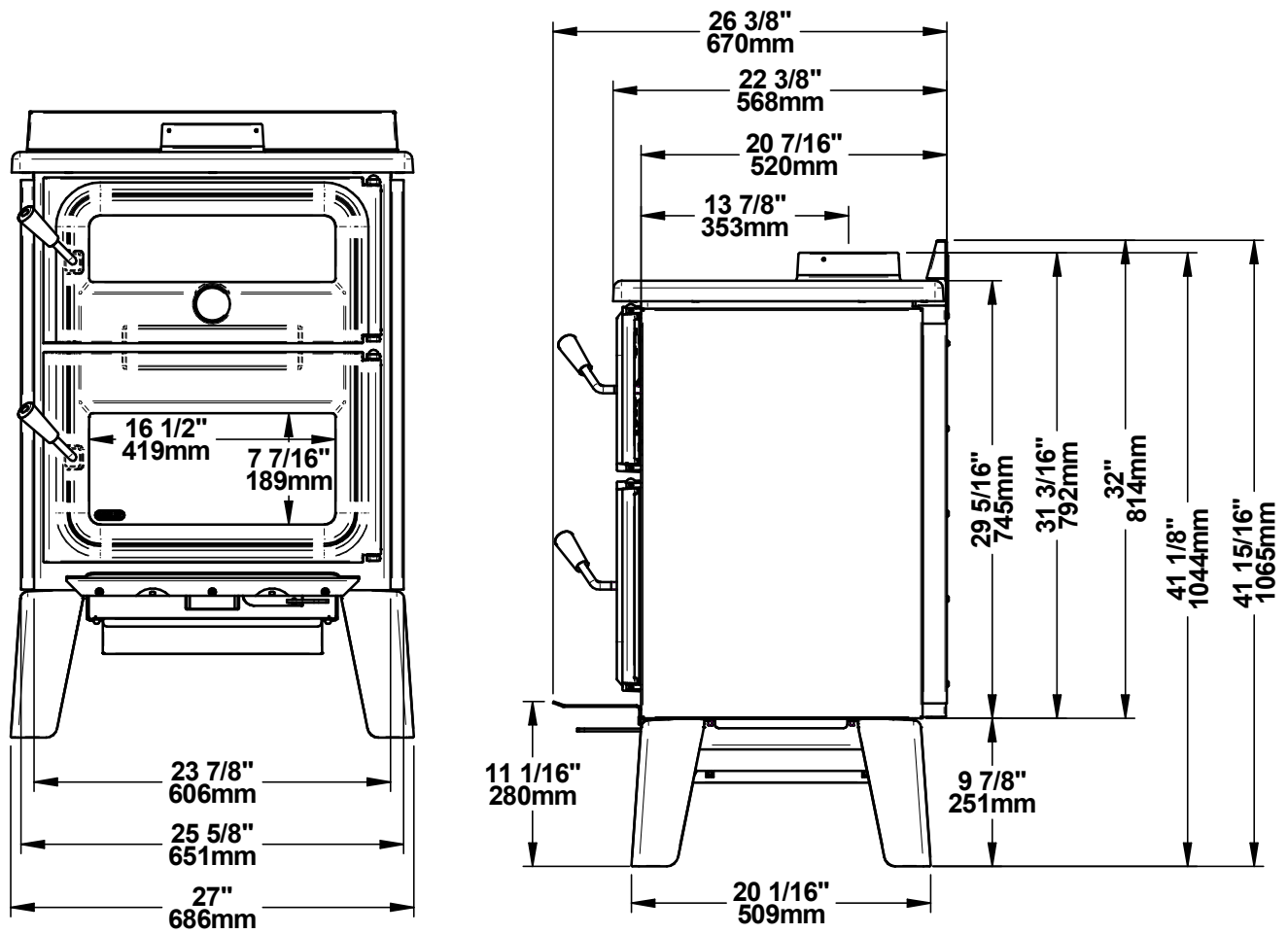

Figure 2: Front view

Figure 3: Side view

2.2.1 Combustion Chamber Dimensions

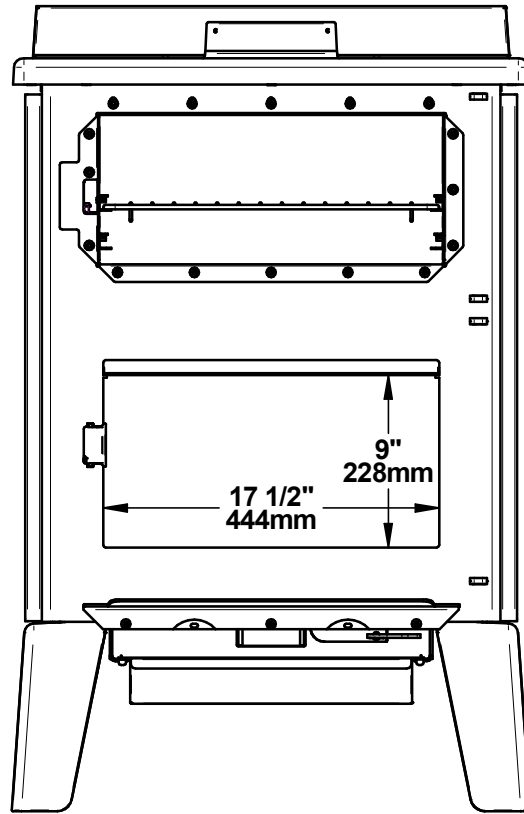

Figure 4: Door opening

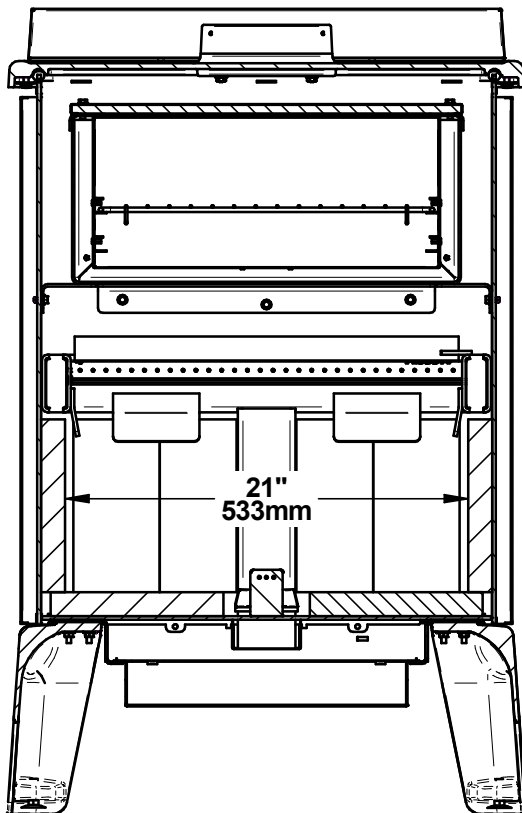

Figure 5: Front view : Combustion chamber

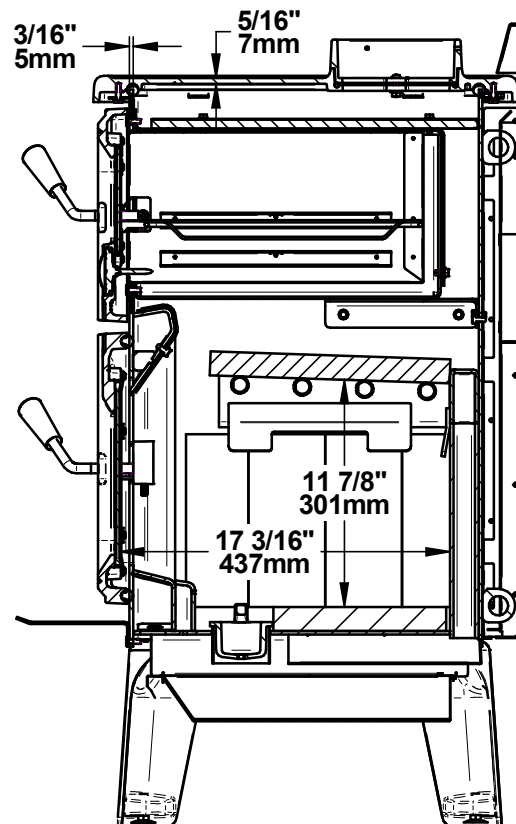

Figure 6: Side view : Combustion chamber

3. Cookstove operation

3.1 Components use

Cooking with a wood-burning cookstove is an art that requires several attempts to get to know and control the appliance. Many factors can influence how the cookstove will heat the oven and the cooking surface. Among them, the type of fuel used and its quality, the size of the logs and when to load before cooking. It is therefore recommended to do several tests to make the Bistro your own.

A	Oven thermometer
B	Combustion chamber
C	Air control
D	Cast iron cooking surface
E	Stainless steel oven
F	Cooking grills
G	Ash pan

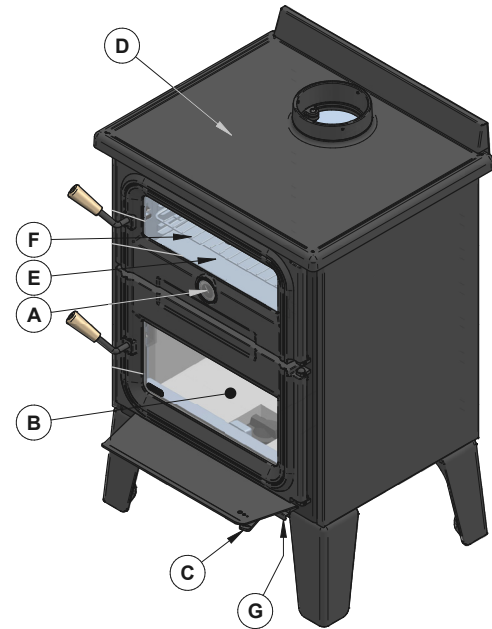

Figure 7: Component Location



It is prohibited to put or store inside the required appliance clearances: alcohol, gasoline, liquid fuel, flammable materials, ashes, paper and wood in the accessory compartment.

3.1.1 Oven

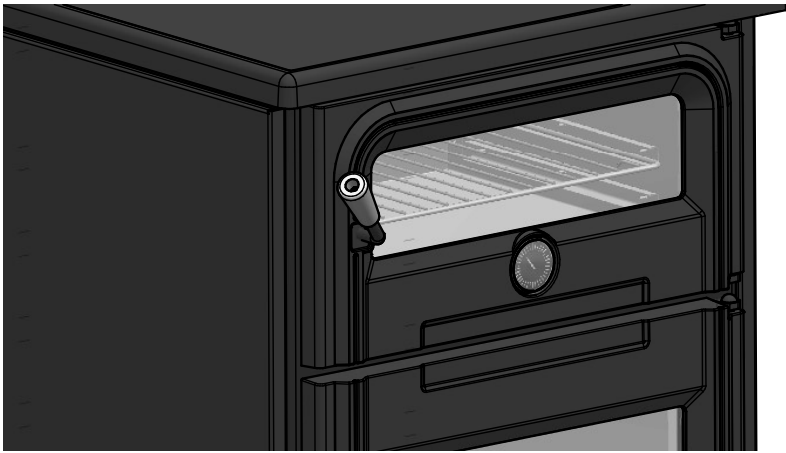

Figure 8: Oven door closed

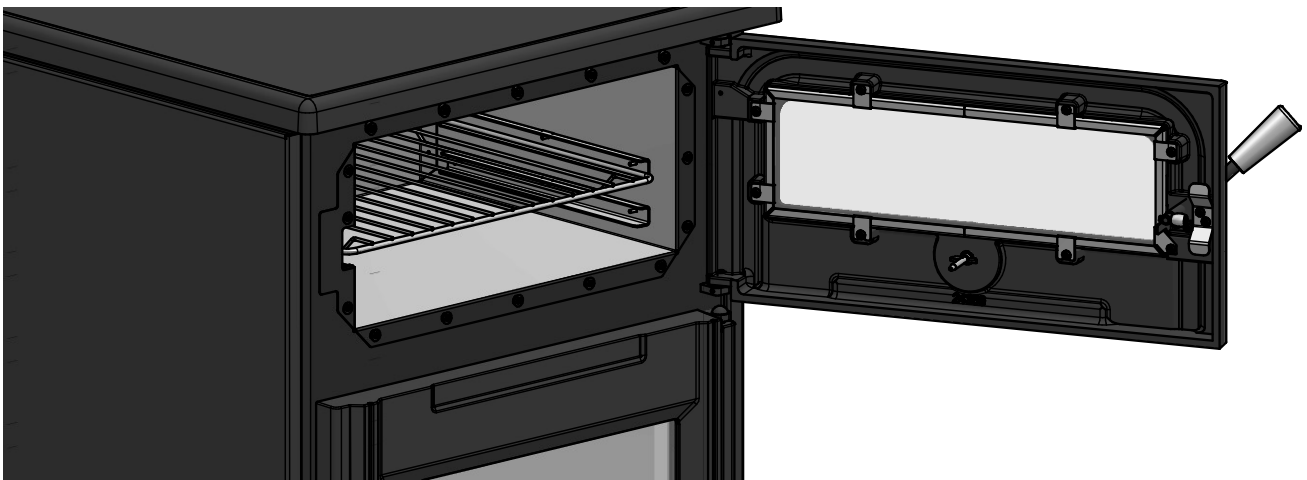

Figure 9: Oven door open

The cooker has a stainless steel oven to cook or bake food. The panoramic glass of the oven door allows you to watch your meal without having to open the door. During cooking, keep the oven door closed to maintain a constant temperature.

The oven cooking temperature can be adjusted using the air intake control (see section "[5.6 Air Intake Control](#)") or by opening or closing the oven door. For even cooking, turn the kitchen accessory used (plate, frying pan, dish, etc.) by 180 ° et half the cooking time.

A cooking grid is supplied with the cooker, allowing food to be cooked at center or bottom of the oven.

The thermometer integrated in the oven door simplifies the temperature reading. The dial can indicate temperatures ranging from 150°F to 750°F (Approximately 50°C to 400°C).

The ambient air inside the oven can vary by approximately 50°F between the hottest point and the coldest point. Typically, the coldest spot is at the front left of the oven, near the doorknob, and the hottest spot is at the rear right, completely opposite. The oven wall temperature is not necessarily equal to room temperature. The thermometer indicates the ambient temperature at a specific point in the oven, which is why the temperature indicated by the thermometer is for reference only.

3.1.2 Cast iron cooking surface

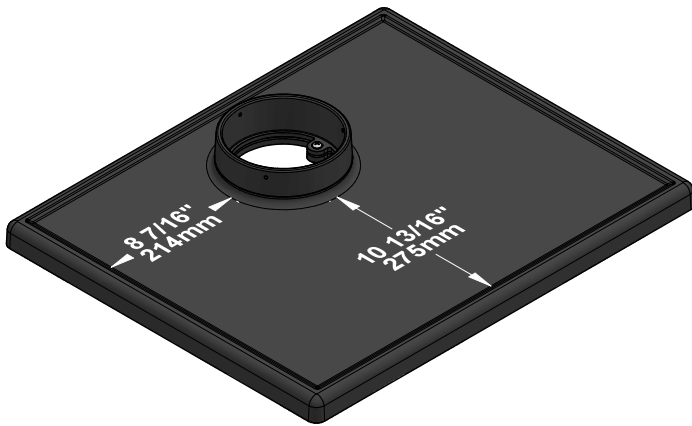

Figure 10: Cast iron cooking surface

ENGLISH

It is not recommended to cook food directly on the cast iron top, as the paint used is not food grade.

The cast iron cooking surface on the top of the range is designed to provide intense heat to allow food to be cooked. It was designed to cook with kitchen accessories (frying pan, saucepan, etc.). It is recommended to use heat resistant cast iron or aluminum accessories for best results. The temperature of the cooking surface is not necessarily uniform.

The temperature of Cast iron top cooking can be adjusted with the air intake control.

To reduce the discomfort due to the heat coming from the combustion chamber, it is recommended to cook on the side of the appliance.

3.2 Gas path

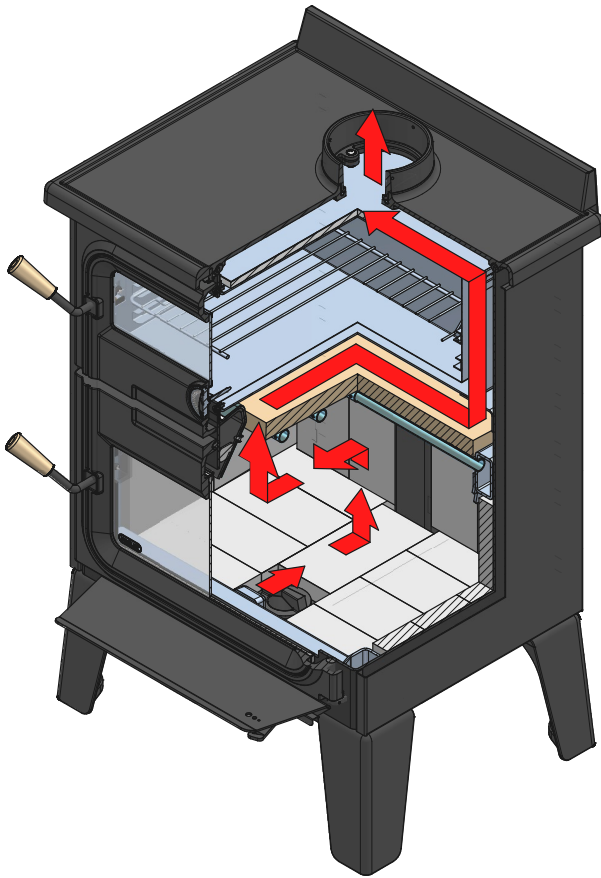

Figure 11: Gas path

The gas path is in fact the circuit followed by the hot gases emitted by burning wood. This circuit is used to heat the stainless steel oven and the cast iron cooking surface.

1. The primary air supply provided by the pilot feeds the wood combustion.
2. Wood burning in the combustion chamber gives off particles and hot gases heading upwards.
3. The secondary air supply from the tubes at the top of the combustion chamber burns a second time gases and particles. This process makes the combustion cleaner and allows to regulate the efficiency of the fire.
4. The gases burned twice are then guided by the baffle towards the front of the combustion chamber.
5. The gases then divide in two, passing through the ducts to the left and right of the oven and joining between the oven and the cooking surface. This portion of the journey is the one that allows for gases to transmit their heat to the oven and to the cooking surface. The path borrowed by gases has an impact on heat distribution. For example, if the fire is further to the left in the combustion chamber, the heat released may pass more through the ducts to the left of the device. The temperature of the cast iron cooking surface may therefore vary according to the path taken by the gases. On the other hand, the oven tends to keep a relatively uniform temperature thanks to its insulation.
6. The gases finally escape through the chimney.

4. Combustibles

Good firewood has been cut to the correct length for the stove, split to a range of sizes and stacked in the open until its moisture content is down to 15% to 20%.

DO NOT BURN:

- **GARBAGE;**
- **LAWN CLIPPINGS OR YARD WASTE;**
- **MATERIALS CONTAINING RUBBER, INCLUDING TIRES;**
- **MATERIALS CONTAINING PLASTIC;**
- **WASTE PETROLEUM PRODUCTS, PAINTS OR PAINT THINNERS, OR ASPHALT PRODUCTS;**
- **MATERIALS CONTAINING ASBESTOS;**
- **CONSTRUCTION OR DEMOLITION DEBRIS;**
- **RAILROAD TIES OR PRESSURE-TREATED WOOD;**
- **MANURE OR ANIMAL REMAINS;**
- **SALT WATER DRIFTWOOD OR OTHER PREVIOUSLY SALT WATER SATURATED MATERIALS;**
- **UNSEASONED WOOD; OR**
- **PAPER PRODUCTS, CARDBOARD, PLYWOOD, OR PARTICLE BOARD. THE PROHIBITION AGAINST BURNING THESE MATERIALS DOES NOT PROHIBIT THE USE OF FIRE STARTERS MADE FROM PAPER, CARDBOARD, SAW DUST, WAX AND SIMILAR SUBSTANCES FOR THE PURPOSE OF STARTING A FIRE IN AN AFFECTED WOOD HEATER.**
- **BURNING THESE MATERIALS MAY RESULT IN THE RELEASE OF TOXIC FUMES OR RENDER THE HEATER INEFFECTIVE AND CAUSE SMOKE.**

4.1 Tree Species

The tree species the firewood is produced from is less important than its moisture content. The main difference in firewood from various tree species is the density of the wood. Hardwoods are denser than softwoods.

Note that hardwood trees like oak, maple, ash and beech are slower growing and longer lived than softer woods like poplar and birch. That makes hardwood trees more valuable. The advice that only hardwoods are good to burn is outdated. Old, leaky cast iron stoves wouldn't hold a fire over a longer period of time unless they were fed large pieces of hardwood. That is no longer true.

4.2 Log Length

Logs should be cut at least 1" (25 mm) shorter than the firebox so they fit in easily. Pieces that are even slightly too long makes loading the stove very difficult. The most common standard length of firewood is 16" (400 mm).

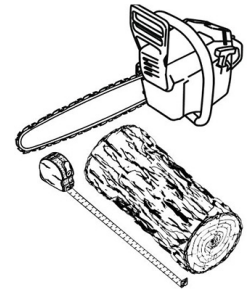

4.3 Piece Size

Firewood dries more quickly when it is split. Large unsplit rounds can take years to dry enough to burn. Even when dried, unsplit logs are difficult to ignite because they don't have the sharp edges where the flames first catch.

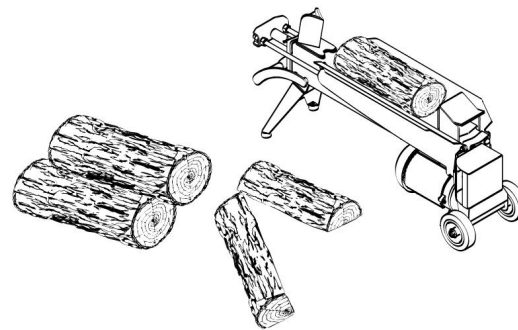
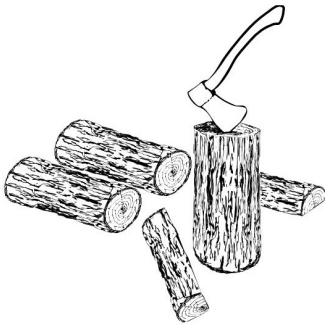

Wood should be split to a range of sizes, from about 3" to 6" (75 mm to 150 mm) in cross section. Having a range of sizes makes starting and rekindling fires much easier.

4.4 Drying Time

Firewood that is not dry enough to burn is the cause of most complaints about wood burning appliances. Continually burning green or unseasoned wood produces more creosote and involves lack of heat and dirty glass door. Firewood with a moisture content between 15% and 20% will allow the stove to produce its optimal output.

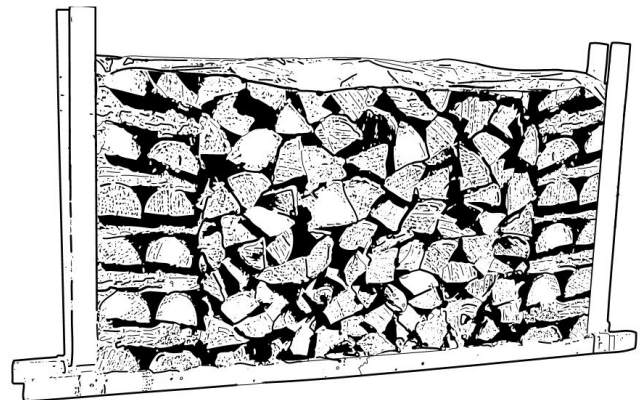

Here are some facts to consider in estimating drying time:

- Firewood bought from a dealer is rarely dry enough to burn, so it is advisable to buy the wood in spring and dry it yourself;
- Drying happens faster in dry weather than in a damp climate;
- Drying happens faster in warm summer weather than in winter weather;
- Small pieces dry more quickly than large pieces;
- Split pieces dry more quickly than unsplit rounds;
- Softwoods like pine, spruce, poplar, and aspen take less time to dry than hardwoods. they can be dry enough to burn after being stacked to air dry only for the summer months;
- Hardwoods like oak, maple and ash can take one, or even two years to dry fully, especially if the pieces are big;
- Firewood dries more quickly when stacked outside in a location exposed to sun and wind; it takes much longer to dry when stacked in a wood shed;
- Ready-to-burn wood with a moisture content of 15% to 20% will allow the appliance to achieve its optimal use.

Use these guidelines to find out if the firewood is dry enough to burn:

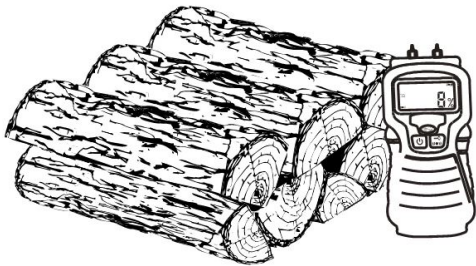

- Cracks form at the ends of logs as they dry;
- The wood turns from white or cream colored to grey or yellow;
- Two pieces of wood struck together sounds hollow;
- Dry wood is much lighter in weight than wet wood;
- The face of a fresh cut feels warm and dry;
- The moisture content read by a moisture meter is between 15% to 20%.

5. Efficient wood combustion

5.1 General Advice

Wood burns best in cycles. A cycle starts when a new load of wood is ignited by hot coals and ends when that load has been consumed down to a bed of charcoal about the same size as it was when the wood was loaded. Trying to produce a steady fire by placing a single log at regular intervals is not recommended. Always place at least three, and preferably more pieces on the fire at a time so that the heat radiated from one piece helps to ignite the pieces next to it.



Prolonged and continuous use at a very low rate of combustion or with very wet wood can cause highly flammable creosote to build up in the flue.

Burning in cycles means the stove door does not need to be opened while the wood is flaming. This is an advantage since it is preventing smoke leaking from the stove when the door is opened as a full fire is burning. This is especially true if the chimney is on the outside wall of the house.

If the door must be open while the fire is flaming, fully open the air control for a few minutes then open the door slowly.

5.2 First Use

Two things happen when burning the first few fires; the paint cures and the internal components are conditioned. As the paint cures, some of the chemicals vaporize. The vapors are not poisonous, but they smell bad. Fresh paint fumes can also trigger false alarms in smoke detectors. When lighting the heater for the first few times, it may be wise to open doors and windows to ventilate the house.

Burn two or three small fires to begin the curing and conditioning process. Then build bigger and hotter fires until there is no longer paint smell from the stove. As hotter and hotter fires are burned, more of the painted surfaces reach the curing temperature of the paint. The smell of curing paint does not disappear until one or two very hot fires have been burned.

5.3 Lighting Fires

Each person cooking with wood develops its own favorite way to light fires. Regardless of the method chosen, the goal should be to have a hot fire burning, quickly. A fire that ignites fast produces less smoke and deposits less creosote in the chimney.

Consult the video using the following link to better visualize the ignition methods:

https://www.youtube.com/watch?v=Y7O0v-nw7QQ&ab_channel=SBI



Never use gasoline, gasoline-type lantern fuel (naphtha), fuel oil, motor oil, kerosene, charcoal lighter fluid, or similar liquids or aerosols to start or 'freshen up' a fire in this wood stove. Keep all such liquids well away from the stove while it is in use.

Here are three popular and effective ways to ignite wood fires.

5.3.1 Conventional Method

The conventional method to build a wood fire is to crumple 5 to 10 sheets of newspaper and place them in the firebox and hold them in place with ten pieces of kindling wood. The kindling should be placed on and behind the newspaper.

Then add two or three small pieces of firewood. Open the air intake control completely and ignite the newspaper. Leave the door slightly ajar.

Once the fire has ignited, the door can be closed with the air control still fully open. When the kindling is almost completely burned, standard firewood pieces can be added.

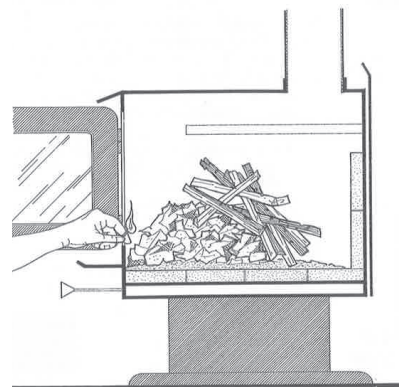

Do not leave the heater unattended when the door is slightly open. Always close and latch the door after the fire ignites.

5.3.2 The Top Down Method

This method is the opposite of the conventional method and only works properly if well-seasoned wood is used.

Place three or four small, split, dry logs in the firebox. Arrange the kindling wood on the logs in two layers at right angles and place a dozen finely split kindling on the second row.

It is possible to use ragged paper but it may not hold in place since it tends to roll while it is burning. The best is to wrap a sheet on itself, grab the ends of the roll and make a knot. Use four or five sheets of paper tied together and put them on top and around the kindling. Open the air intake control completely, ignite the paper and close the door.

The top down fire method has two advantages over the traditional method: first, the fire does not collapse on itself, and it is not necessary to add wood gradually since the combustion chamber is full before the fire is lit.

5.3.3 *Two Parallel Logs Method*

Two spit logs are placed in the firebox with a few sheets of twisted newspapers in between the logs. Fine kindling is added across the two logs and some larger kindling across those, log cabin style. Newspaper is lit.

5.3.4 *Using Fire Starters*

Commercial fire starters can be used instead of a newspaper. Some of these starters are made of sawdust and wax and others are made of specialized flammable solid chemicals. Always follow the package directions when using. Gel starters can also be used, but only to light a fire, in a cold combustion chamber without hot embers inside.

5.4 **Combustion Cycles**

Wood-burning cookstove don't have a steady heat output. It is normal for the heat output to increase after a new load of wood is ignited and to gradually decrease throughout the burning cycle. This increasing and decreasing temperature can be matched with the household routines. For example, add small pieces of wood for fast and intense cooking heat or bigger pieces for long lasting heat to simmer a dish.

Wood burns best in cycles. A cycle starts when a new load of wood is ignited by hot coals and ends when that load has been consumed down to a bed of charcoal about the same size as it was when the wood was loaded.

Trying to produce a steady heat output by placing a single log on the fire at regular intervals is not recommended. Always place at least three, and preferably more pieces on the fire at a time so that the heat radiated from one piece helps to ignite the pieces next to it. Each load of wood should provide several hours of heat. The size of each load may vary depending on the amount of heat required.

Burning in cycles means the loading door does not need to be opened while the wood is flaming. This is an advantage since it is preventing smoke leaking from the heater when the door is opened as a full fire is burning. This is especially true if the chimney is on the outside wall of the house.

If the door must be opened while the fire is flaming, fully open air control for a few minutes then open the door slowly.

5.5 Rekindling a Fire

Generally, when you need to cook, it is time to reload. Remove excess ash from the front of the firebox and bring the ashes forward. Place a new load of wood on, and at the back of the embers. Open the air control completely and close the door.

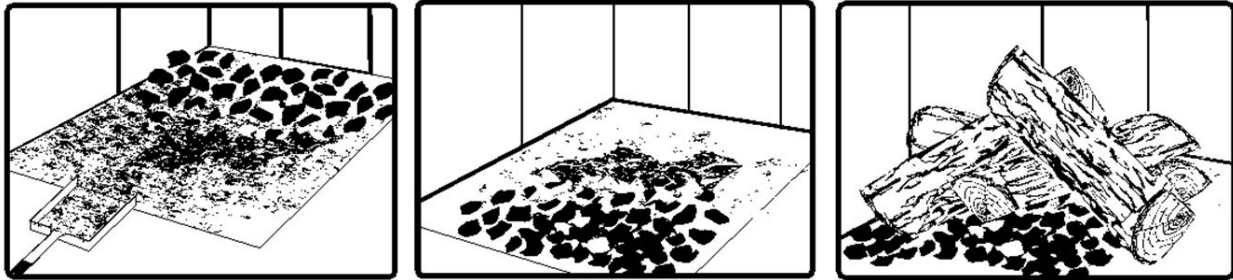

Raking the coals is useful for two reasons. First, it brings them near where most of the combustion air enters the firebox. This will ignite the new load quickly. Secondly, the charcoal will not be smothered by the new load of wood. When the embers are simply spread inside the combustion chamber, the new load smoulder for a long time before igniting.

Close the air control only when the firebox is full of bright turbulent flames, the wood is charred, and its edges are glowing.

The heater should not be left unattended during ignition and the fire should not burn at full intensity for more than a few minutes.

When lighting a new load, the appliance produces a heat surge. This heat boost is useful for reheating the oven and cast iron cooking surface, but can give a feeling of extra heat in the room if it is already hot there. Therefore, it is better to have a cooler room than desired to put back a load of wood for to cook.

5.6 Air Intake Control

Once the firewood, firebox and chimney are hot, air intake can be reduced to achieve a steady burn.

As the air intake is reduced, the burn rate decreases. This has the effect of distributing the thermal energy of the fuel over a longer period of time. In addition, the flow rate of exhaust through the appliance and flue pipe slows down, which increases the duration of the energy transfer of the exhaust gases. As the air intake is reduced, the flame slows down.

If the flames diminish to the point of disappearing, the air intake has been reduced too early in the combustion cycle or the wood used is too wet. If the wood is dry and the air control is used properly, the flames should decrease, but remain bright and stable.

On the other hand, too much air can make the fire uncontrollable, creating very high temperatures in the unit as well as in the chimney and seriously damaging them. A reddish glow on the unit and on the chimney components indicates overheating. Excessive temperatures can cause a chimney fire.

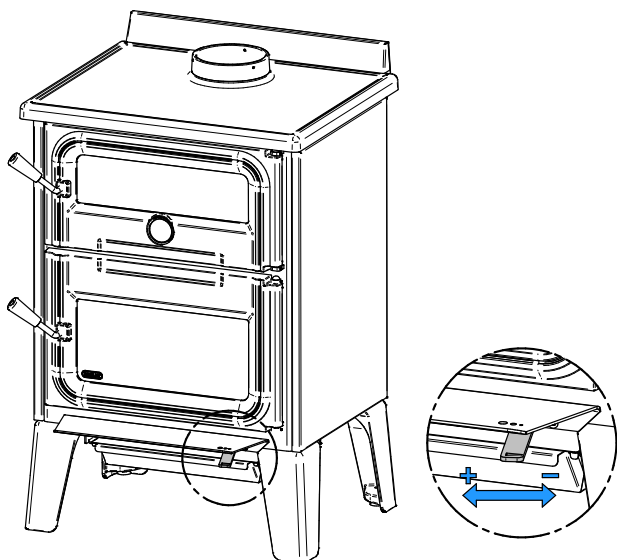

Figure 12: Air Intake Control

The control of the primary and secondary air inlet is simultaneous and is done with a single regulation control, located under the combustion chamber door.

The optimum regulation of the air inlet can vary according to various factors, such as the chimney flue, the temperature of the cookstove and, the quality of the firewood (moisture, size and shape).

Do not alter the air regulation control to increase firing for any reason.

5.6.1 *Regulating the air during lighting*

Opening the air inlet completely is mandatory during the lighting, and it is recommended to leave the door ajar during lighting as well, in order to avoid condensation of fumes on the glass. Wait enough time (until the hearth has warmed up) before starting to regulate the air inlet.

5.6.2 *Regulating the air during combustion*

Controlling the air intake is the recommended way to help adjust the temperature of the cooking surface and one of the two recommended ways to adjust the oven temperature. Once the fire is well established in the combustion chamber, when the flames are vivid and there is a good bed of embers, it is possible to close the air intake. The more it will be reduced, the more the combustion will be regulated to stretch over time. On the other hand, you need a very strong combustion to completely shut off the air intake. It is recommended to reduce it between 15 and 40%.

5.7 Carbon Monoxide

When unburned logs remain in the firebox and the flame disappears, go outside and look at the chimney exit. If there is visible smoke, it means that there is still combustible to burn but that the fire lacks air to burn properly. In this situation, the CO rate will increase so it is important to react. Open the door slightly and move the log with a poker. Turn it over and create a passage for the air below, making a trench with the coal bed. Add small pieces of wood to restart the combustion.

6. Maintenance

This cookstove will give many years of reliable service if used and maintained properly. Some of the internal components of the firebox, such as vermiculite and baffle will wear over time under intense heat. Defective parts should always be replaced with original parts. Firing each load hot to begin a cycle will not cause premature deterioration of the cookstove. However, letting the cookstove run with the air intake fully open for the entire burn cycles can cause damage over time. The hotter the cookstove becomes throughout burn cycles, the more quickly its components will deteriorate. For this reason, **the cookstove should never be left unattended while a new load is being fired hot.**

6.1 Combustion Chamber

The cookstove cleaning frequency depends on the type and quality of combustible used. A high humidity rate, ashes, soot, or chemical components in the wood could increase the number of cleanings necessary. Therefore, it is important to pay attention to the combustible used.

To get the maximum performance from the cookstove, ashes should be removed regularly. The use of a personal, central, or commercial vacuum cleaner to clean up the cookstove is not recommended. Ash particles can damage the vacuum engine. Furthermore, hot ashes could ignite the content of the vacuum. The use of a specialized ash vacuum is highly recommended.

6.2 Removing ashes

It is recommended to clean the ashes only when there is an accumulation that is blocking the pilot in front of the combustion chamber or when they come out too easily when opening the door or by putting logs. There are two ways to dispose of ashes:

1. By removing the ash plug and pushing them into the ash drawer through the opening using a shovel.
2. By directly using a shovel in the combustion chamber and putting it in a container.

Always operate the cookstove with the ash drawer in place.

The best time to remove ashes is when the appliance is relatively cold, but there is still a little draft to suck the ash dust and prevent it from entering the room. Ashes should be placed in a metal container with a tight cover. The container should be placed on a non-combustible floor or on the ground away from any flammable material. Ashes can contain hot embers that can stay hot for several days. If the ashes are buried in the ground or scattered on site, they should be kept in the closed metal container until they are completely cooled. No other waste should be placed in this container.



NEVER STORE ASHES INDOORS OR IN A NON-METALLIC CONTAINER OR ON A WOODEN DECK.

6.3 Grills and cast iron cooking surface

Clean the grills with a brush and mild soap.

To clean the cast iron cooking surface, wipe it with a soft and damp cloth. **Do not clean the surface when it is hot.** If rust or scratches appear, follow the instructions in [section 6.4 Cleaning and painting](#) to repair the surface.

6.4 Cleaning and Painting

Painted surfaces can be wiped down with a soft, damp cloth. If the paint is scratched or damaged, it is possible to repaint the heater with a heat-resistant paint. **Do not clean or paint the appliance when it is hot.** Before painting, the surface should be sanded lightly with sandpaper and then wiped off to remove dust. Apply two thin layers of paint.

6.5 Refractory Materials and Baffle

Inspect the firebricks or the refractory panels and the baffle for damage periodically and replace anything that is broken.

Operation of the heater with a cracked or missing baffle may cause unsafe temperatures and hazardous conditions and will void the warranty.

6.6 Glasses

The cookstove has two glasses to maintain. The combustion chamber glass has a gasket while the furnace does not.

6.6.1 Cleaning

Under normal conditions, the door glass should stay relatively clear. If the firewood is dry enough and the operating instructions in this guide are followed, a whitish, dusty deposit will form on the inner surface of the glass after a week or so of use. This is normal and can be easily removed when the heater is cold by wiping with a damp cloth or paper towel and then drying.

When the stove runs at a low combustion rate, light brown stains may form, especially in the lower corners of the glass. This indicates that the fire has been smoky and some of the smoke has condensed on the glass. It also indicates incomplete combustion of the wood, which also means more smoke emissions and faster formation of creosote in the chimney.

The deposits that form on the glass are the best indication of the fuel quality and success in properly using the stove. These stains can be cleaned with a special wood stove glass cleaner. **Do not use abrasive products to clean the glass.**

The goal should be having a clear glass with no brown stains. If brown stains appear regularly on the glass, something about the fuel or the operating procedure needs to be changed. When brown streaks are coming from the edge of the glass, it is time to replace the gasket around the glass.

The glass gasket should be self-adhesive. Always replace the gasket with a genuine one.

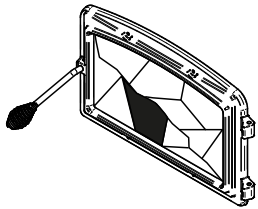

Do not clean the glass when the stove is hot.

Do not abuse the glass door by striking or slamming shut.

Do not use the stove if the glass is broken.

6.6.2 Replacement

The glass used is a ceramic glass, 5/32" (4 mm) thick, tested to reach temperatures up to 1400° F. If the glass breaks, it must be replaced with one having the same specification.

To remove or replace the glass (D):

THE IMAGES SHOWN ARE FOR GUIDANCE ONLY AND MAY BE DIFFERENT FROM YOUR PRODUCT, BUT THE ASSEMBLY REMAINS THE SAME.

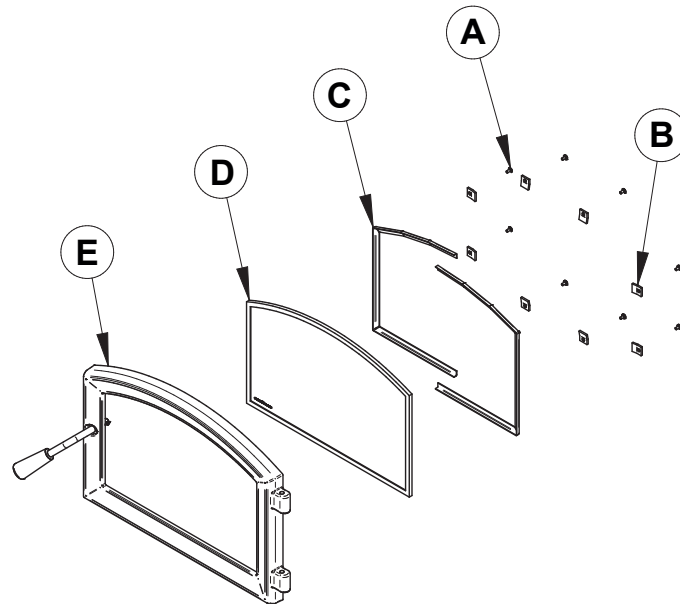

1. Unscrew the setscrew from the hinge at the top of the door to release the rivet (rod inserted in the hinge). Remove the rivet while retaining the door. Lift the door **(E)** to remove it from the lower hinge and place it on a soft, level surface.
2. Remove the screws **(A)**, the glass retainers **(B)**, and the metal frames **(C)**.
3. Remove the glass **(D)**. If it is damaged install a new one in place. The replacement glass must have a gasket all around (see procedure below).
4. Reinstall the glass, being careful to centre the glass in the door and not to over-tightening the retaining screw.

The two main causes of broken door glass are uneven placement in the door and over-tightening the retaining screws.

6.6.3 Gasket

The glass gasket is flat, adhesive-backed, woven fibreglass. The gasket must be centred on the edge of the glass.

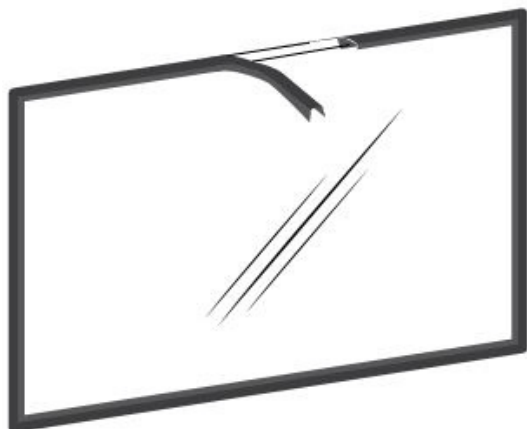

1. Follow the steps of the previous section to remove the glass.
2. Remove the old gasket and clean the glass thoroughly.
3. Peel back a section of the paper covering the adhesive and place the gasket on a table with the adhesive side up.
4. Stick the end of the gasket to the middle of one edge, then press the edge of the glass down onto the gasket, taking care that it is perfectly centred on the gasket.
5. Peel off more of the backing and rotate the glass. The gasket must not be stretched during installation.
6. Cut the gasket to the required length.
7. Pinch the gasket onto the glass in a U shape, all around the glass.

ENGLISH

6.6.4 Replacing the Glass Door and the Glass Gasket

The glass used in the this cookstove is 4 mm thick, and was tested to reach temperatures up to 1400° F. It has the following dimensions:

- Oven (W x H): 17.5" x 5.375" (without gasket)
- Combustion chamber (W x H): 17-5/8" x 9-9/16" (with gasket)

If the glass breaks, it must be replaced with one having the same specification. Contact your dealer to obtain a genuine replacement part.

6.6.5 Door sealing

In order for the stove to burn at its best efficiency, the door must provide a perfect seal with the firebox. The tightness of the door seal can be verified by closing and latching the door on a strip of paper. The test must be performed all a round the door. If the paper slips out easily anywhere, either adjust the door or replace the gasket.

Perform this test only when the device is cold.

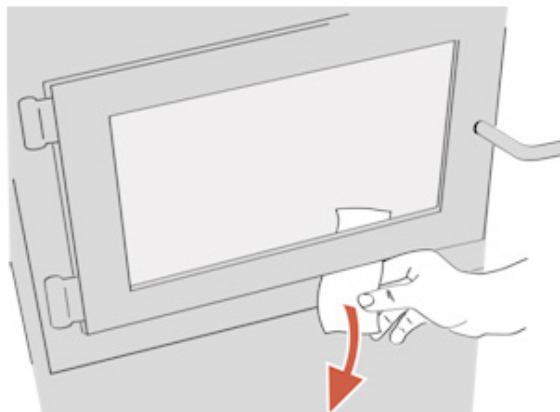

6.6.6 Adjustment of the combustion chamber door

In order for the stove to burn at its best efficiency, the door must provide a perfect seal with the firebox. Therefore, the gasket should be inspected periodically to check for a good seal. The gasket seal may be improved with a simple latch mechanism adjustment:

1. Remove the split pin by pulling and turning it using pliers.
2. Turn the handle one counterclockwise turn to increase pressure.
3. Reinstall the split pin with a small hammer.

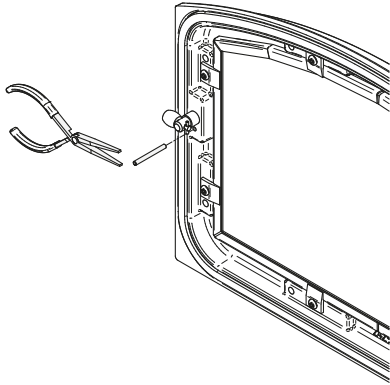

Figure 13: Removing the split pin

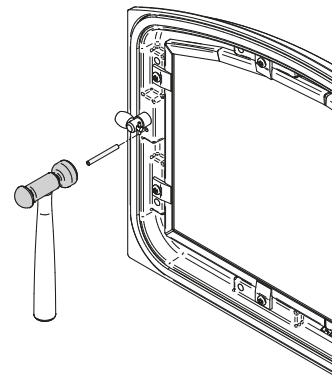

Figure 14: Installing the split pin

6.6.7 Door Alignment

To align, open the door and loosen the pressures screws located on the lower and upper hinges of the door using a 3/32" Allen key to free the adjustable hinge rods.

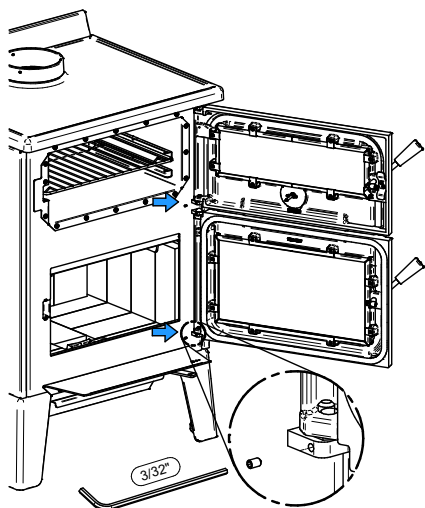

Figure 15: Release eccentric hinges

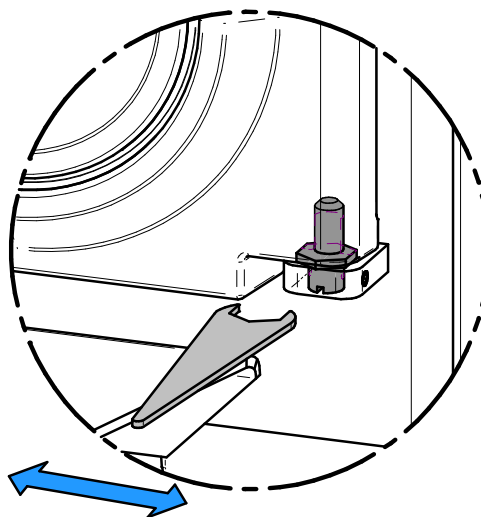

Figure 16: Adjust eccentric hinges

Using a flat screwdriver, turn the adjustable hinge rods in the direction shown to adjust the doors. Tighten all door hinge pressure screws when they are at the desired positions. Configurations 1-2-3-4-5-6-7-8, show in which direction these act on the adjustment of the door.

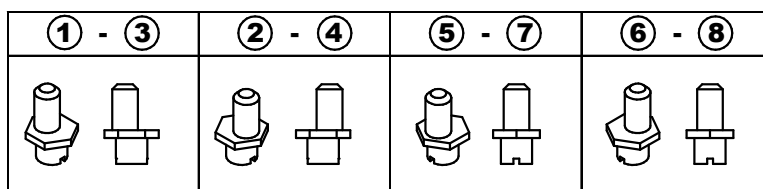

Figure 17: Eccentric hinges depth adjustment

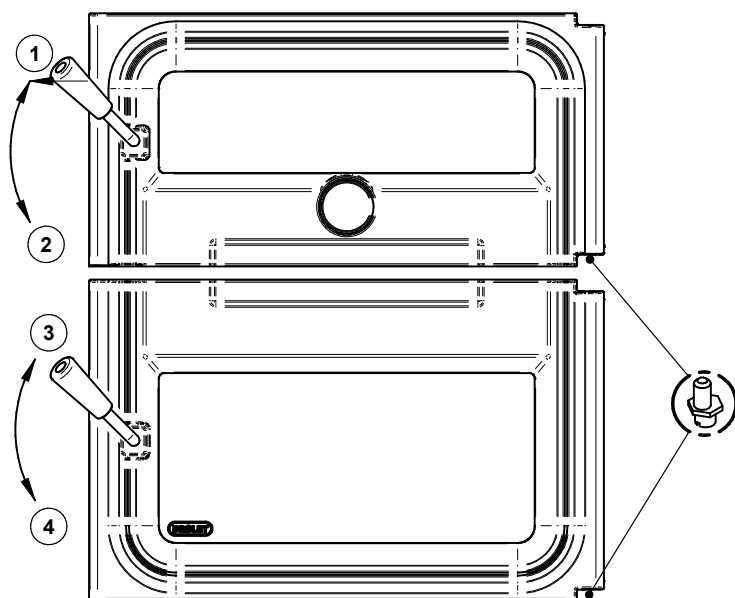

Figure 18: Doors adjustment

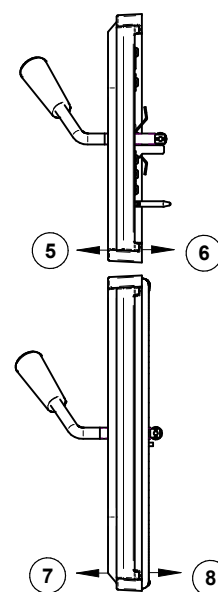

Figure 19: Eccentric hinges lateral adjustment

6.6.8 Gasket

It is important to replace the gasket with another having the same diameter and density to maintain a good seal.

1. Remove the door and place it face-down on something soft like a cushion of rags or a piece of carpet.
2. Remove the old gasket from the door. Use a screwdriver to scrape the old gasket adhesive from the door gasket groove.
3. Apply a bead of approximately $\frac{3}{16}$ " (5 mm) of high temperature silicone in the door gasket groove. Starting from the middle, hinges side, press the gasket into the groove. The gasket must not be stretched during installation.
4. Leave about $\frac{1}{2}$ " long of the gasket when cutting and press the end into the groove. Tuck any loose fibers under the gasket and into the silicone.
5. Close the door. Do not use the stove for 24 hours.

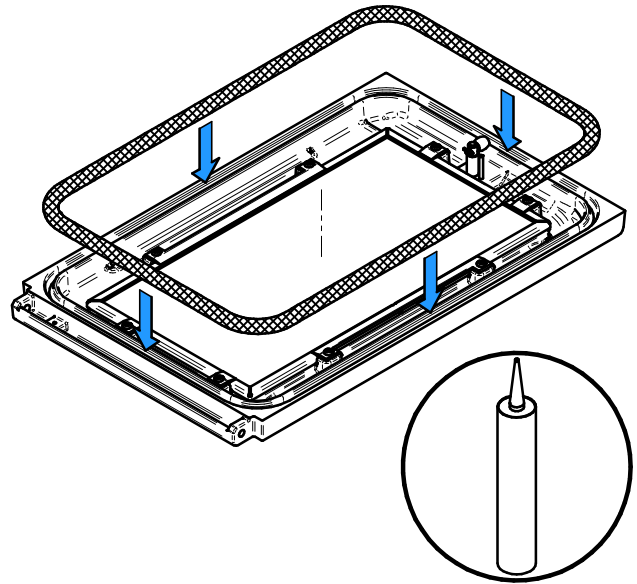
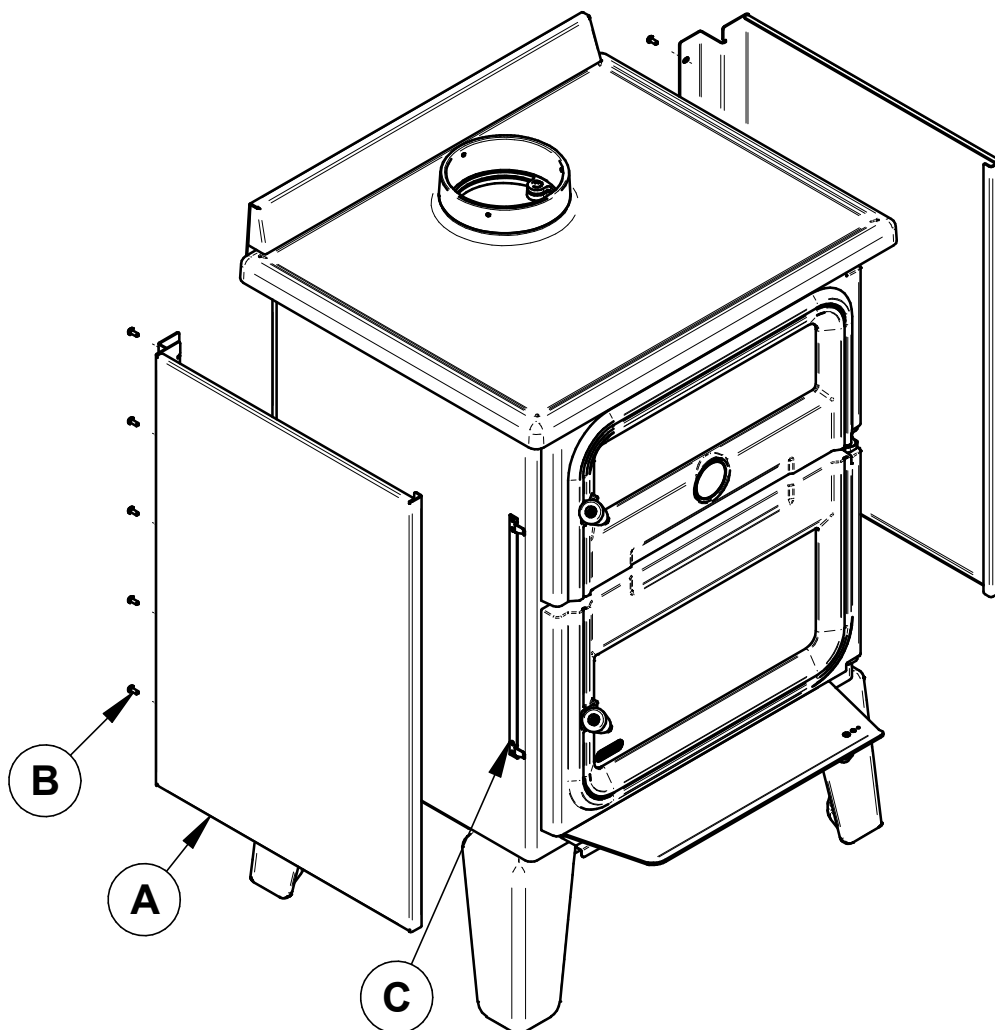

Figure 20: Gasket

6.7 Decorative Panels

To remove the decorative panel **(A)**, remove the screws **(B)** and push forward on the panel to unhook it from the bracket **(C)**.



6.8 Fresh Air Intake Kit Installation

The installation of a fresh air intake kit **(A)** requires an insulated fresh air intake pipe **(B)** HVAC type (must meet ULC S110 or UL 181 class 0 or class 1), sold separately.

It is mandatory to install the fresh air intake in a mobile home.

Refer to air intake kit installation instructions for more details.

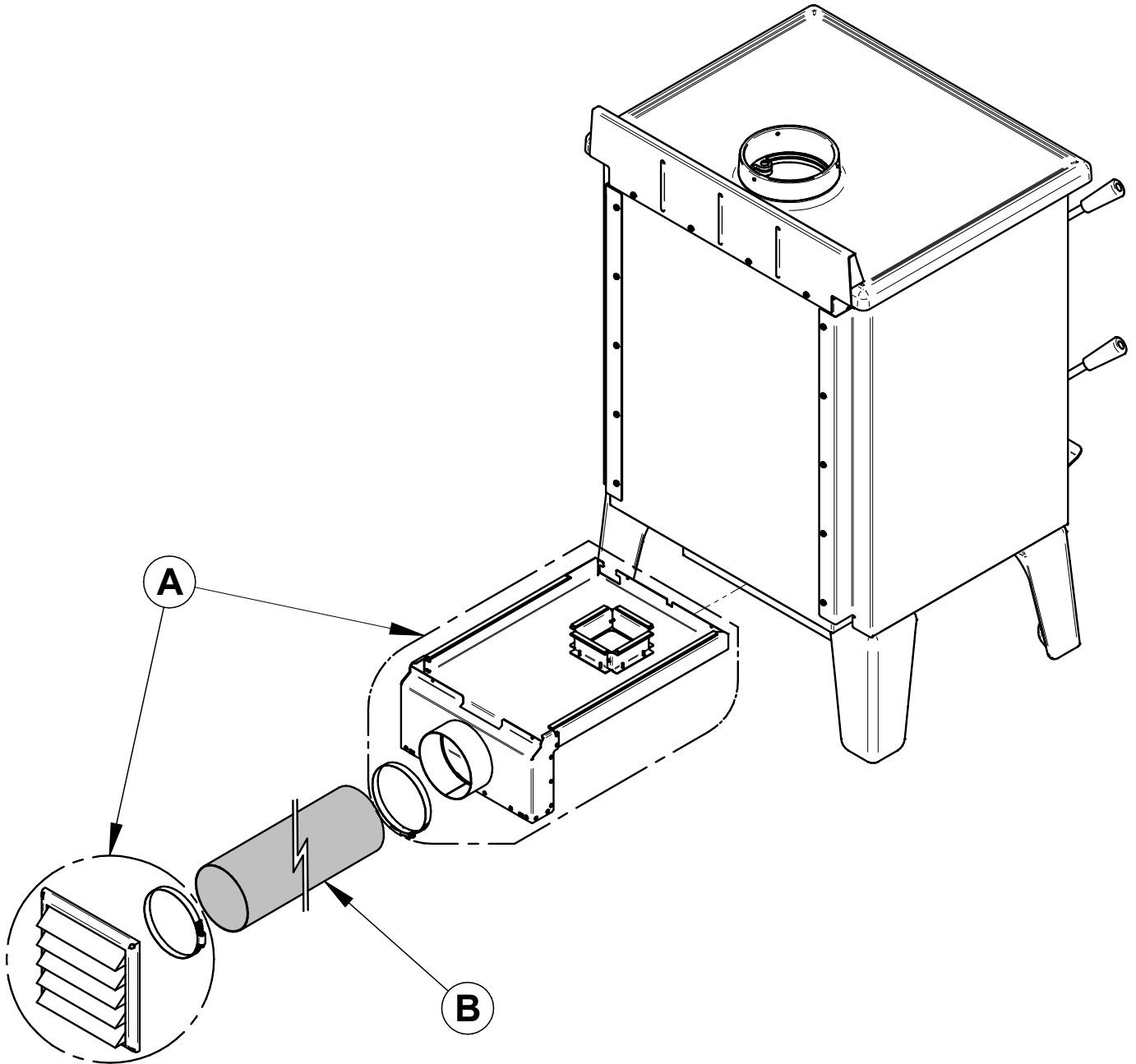

6.9 Air Tubes And Baffle Installation

1. Starting with the rear tube, lean and insert the right end of the secondary air tube into the rear right channel hole. Then lift and insert the left end of the tube into the rear left channel.

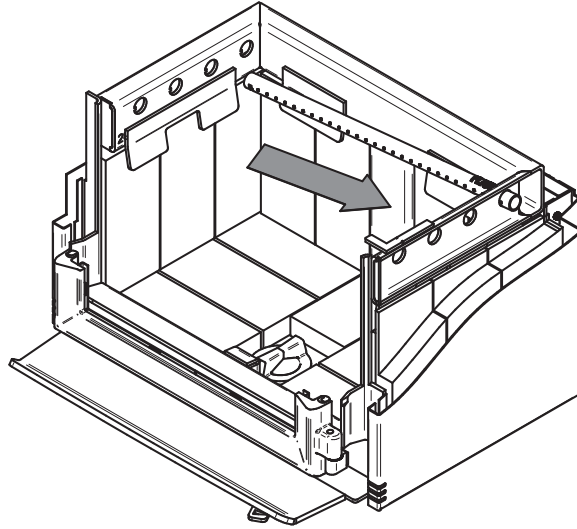

2. Align the notch in the left end of the tube with the key of the left air channel hole. Using a « Wise grip » hold the tube and lock it in place by turning the tube as shown. Make sure the notch reaches the end of the key way.
3. Put the baffle in place.
4. Repeat steps 1 and 2 for the three other tubes.
5. To remove the tubes use the above steps in reverse order.

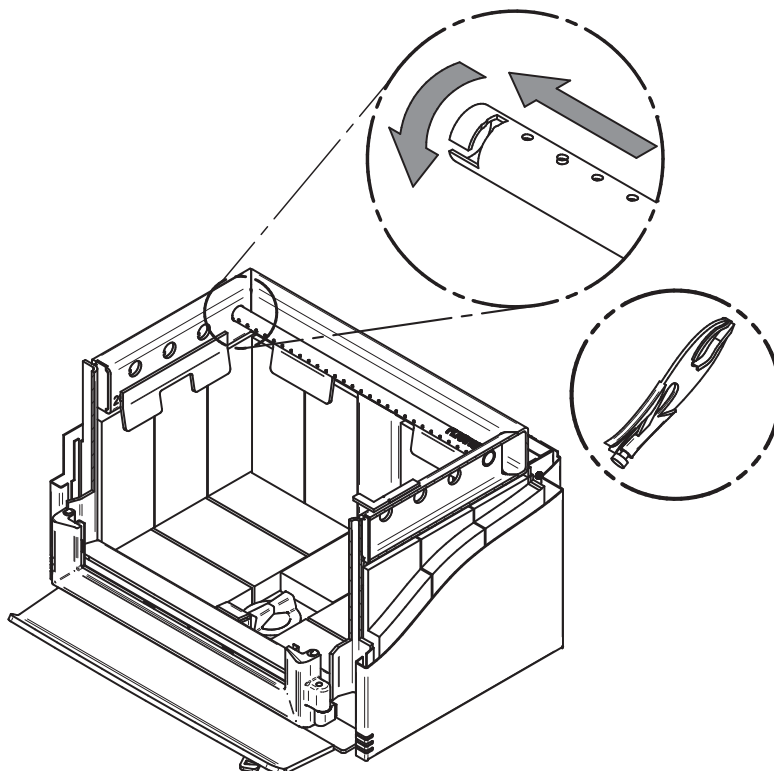

Note that secondary air tubes (B) can be replaced without removing the baffle board (A) and that all tubes are not necessarily identical (look at the part number on the tube).

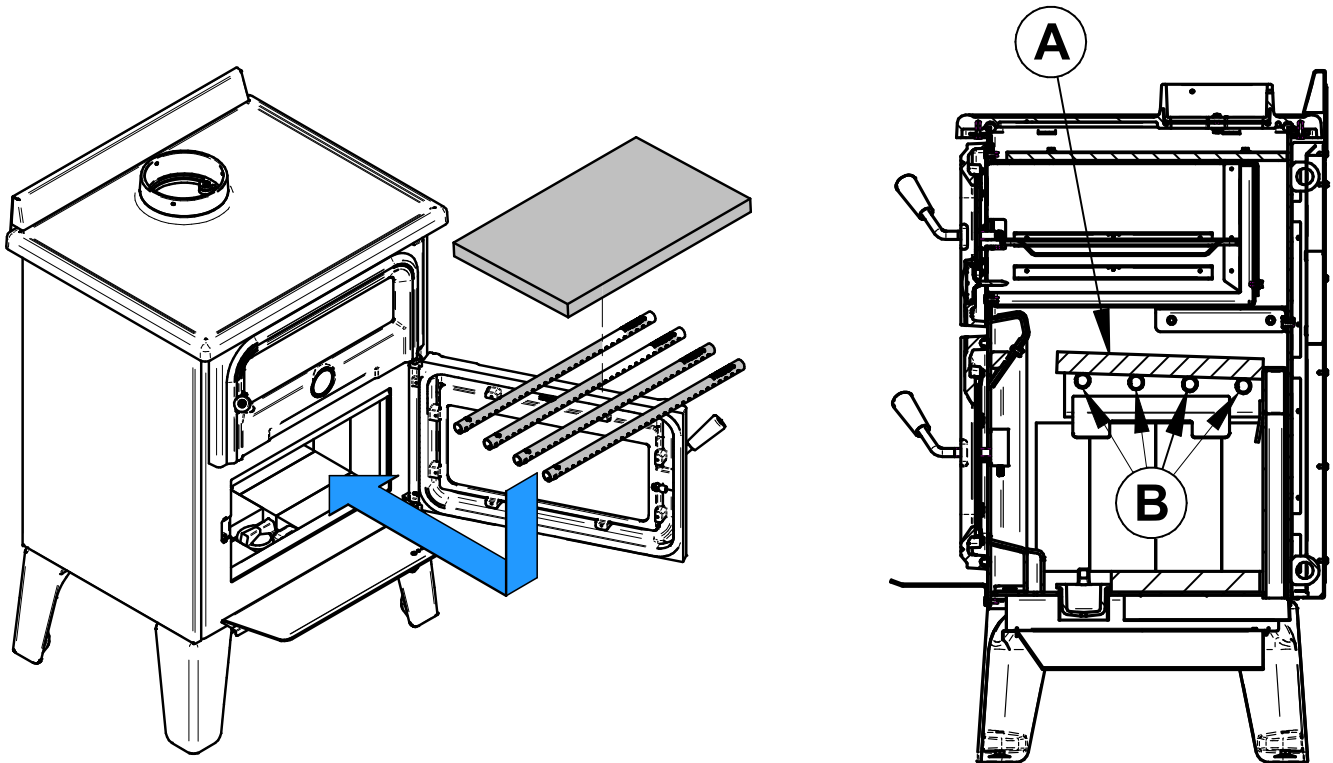

6.10 Handles installation

Insert, in order, the natural wood handle (A), the washer (B) and the screw (C) on the handle rod of each door. Screw everything in place with a square head screwdriver.

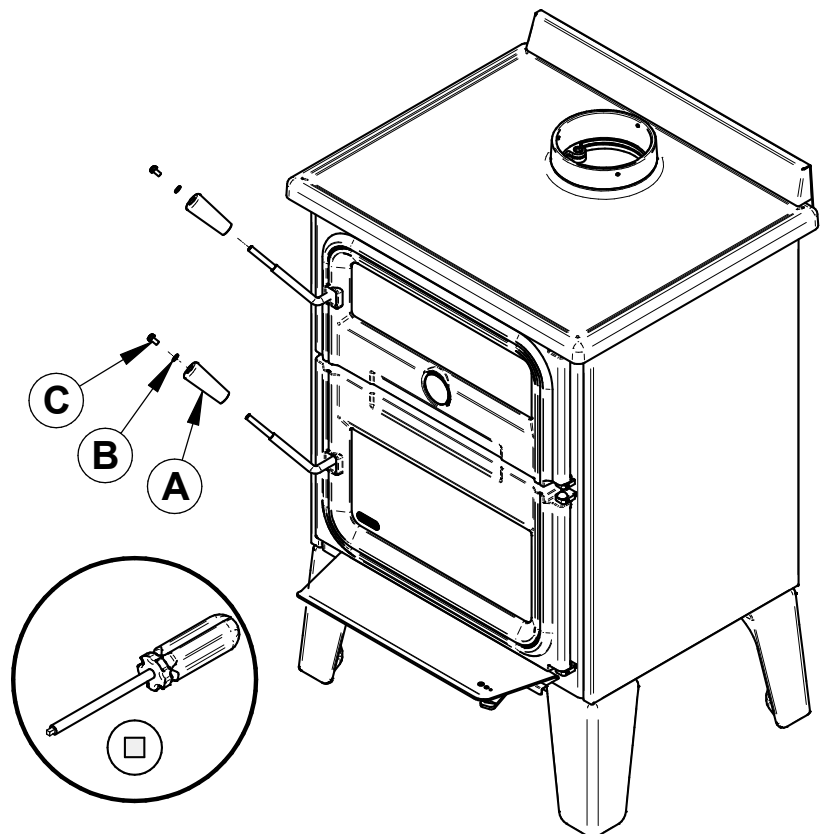

6.11 Mobile Home Installation

THE IMAGES SHOWN ARE FOR GUIDANCE ONLY AND MAY BE DIFFERENT FROM YOUR PRODUCT,
BUT THE ASSEMBLY REMAINS THE SAME.

For a stove on legs, install a plate (**L**) on each leg and screw it in place with the proper hardware (**M**). Plates are included in the combustion chamber, but the proper hardware to screw the legs in place is not included.

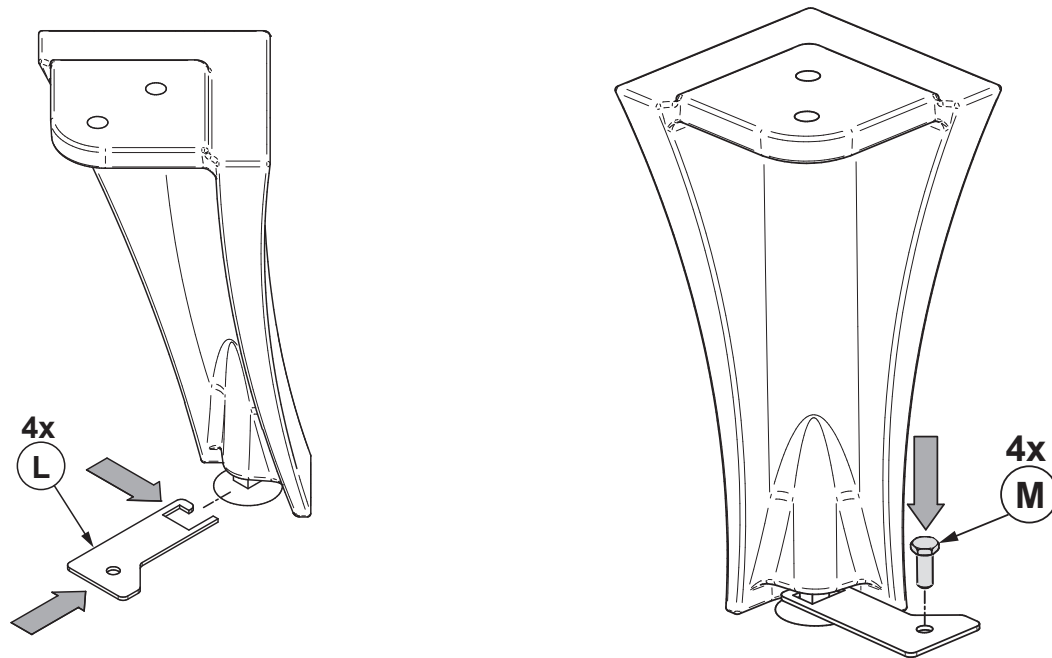

6.12 Exhaust System

Wood smoke can condense inside the chimney, forming a inflammable deposit called creosote. If creosote builds up in the system, it can ignite when a hot fire is burned in the stove. A very hot fire can progress to the top of the chimney. Severe chimney fires can damage even the best chimneys. Smouldering, smoky fires can quickly cause a thick layer of creosote to form. When the stove is operated properly, the exhaust from the chimney is mostly clear and creosote builds up more slowly.

«Creosote - Formation and Need to Removal

When wood is burned slowly, it produces tar and other organic vapors, which combine with expelled moisture to form creosote. The creosote vapors condense in the relatively cooler chimney flue of a slow-burning fire. As a result, creosote residue accumulates on the flue lining. When ignited this creosote makes an extremely hot fire.

The chimney connector and chimney should be inspected at least once every two months during the heating season to determine if a creosote buildup has occurred. If a significant layer of creosote has accumulated ($\frac{1}{8}$ " [3 mm] or more) it should be removed to reduce the risk of a chimney fire.»

6.12.1 Frequency

It is not possible to predict how much or how quickly creosote will form in the chimney. It is important, therefore, to check the build-up in the chimney monthly until the rate of creosote formation is determined. Even if creosote forms slowly in the system, the chimney should be cleaned and inspected at least once each year.

Establish a routine for the fuel, wood burner and firing technique. Check daily for creosote build-up until experience shows how often you need to clean to be safe. Be aware that the hotter the fire the less creosote is deposited, and weekly cleaning may be necessary in mild weather even though monthly cleaning may be enough in the coldest months.

Contact your local municipal or provincial fire authority for information on how to handle a chimney fire. Have a clearly understood plan to handle a chimney fire.

6.12.2 Sweeping the Chimney

Chimney sweeping can be a difficult and dangerous job. People with no chimney sweeping experience will often prefer to hire a professional chimney sweep to inspect and clean the system for the first time. After seeing the cleaning process, some will choose to do it themselves. The chimney should be checked regularly for creosote build-up.

Inspection and cleaning of the chimney, but mainly cleaning of the gas path, can be facilitated by removing the baffle. See section «[6.9 Air Tubes And Baffle Installation](#)»

To properly clean all the gas path, it is recommended to use the cleaning brush. To make sure you reach all corners, especially the top and sides of the oven, it is recommended remove the chimney.

N.B. It is possible to remove the chimney after sweeping. The residues will thus all have fallen on top of the oven. You can also remove the chimney before sweeping and make sure to put a container as airtight as possible at the end of the chimney (where it has been unscrewed), to collect the residues that will fall during the sweeping.

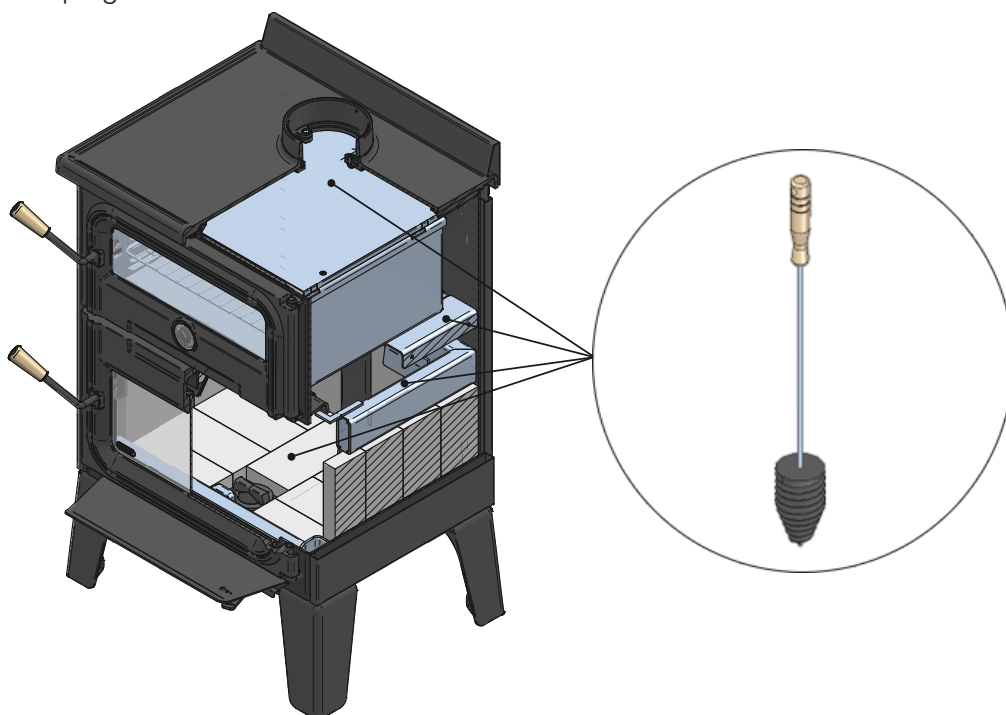
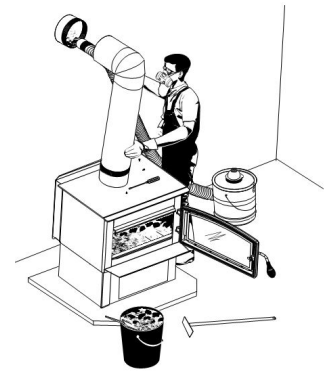

6.12.3 Chimney Fire

Regular chimney maintenance and inspection can prevent chimney fires. If you have a chimney fire, follow these steps:

1. Close the stove door and the air intake control;
2. Alert the occupants of the house of the possible danger;
3. If you require assistance, alert the fire department;
4. If possible, use a dry chemical fire extinguisher, baking soda or sand to control the fire. Do not use water as it may cause a dangerous steam explosion;

Do not use the appliance again until the stove and its chimney have been inspected by a qualified chimney sweep or a fire department inspector.

PART B - INSTALLATION

7. General Information

7.1 Security

- Read this manual completely before installing the cookstove. It is important to fully respect the installation instructions. If the cookstove is not correctly installed, it could result in a fire, bodily injuries or even death.
- The information given on the certification label affixed to the appliance always overrides the information published, in any other media (owner's manual, catalogues, flyers, magazines and web sites).
- Mixing of appliance components from different sources or modifying components may result in hazardous conditions. Where any such changes are planned, Stove Builder International Inc. Should be contacted in advance.
- **DO NOT CONNECT TO OR USE IN CONJUNCTION WITH ANY AIR DISTRIBUTION DUCTWORK UNLESS SPECIFICALLY APPROVED FOR SUCH INSTALLATION.**
- **DO NOT CONNECT THIS UNIT TO A CHIMNEY FLUE SERVING ANOTHER APPLIANCE.**
- **HOT WHILE IN OPERATION, KEEP CHILDREN, CLOTHING AND FURNITURE AWAY. CONTACT MAY CAUSE SKIN BURNS. GLOVES MAY BE NEEDED FOR THE STOVE OPERATION.**
- **WARNING: DO NOT INSTALL IN THE SLEEPING ROOM.**
- **MAY BE INSTALLED IN A MOBILE HOME:**
 - **THE INSTALLATION REQUIRES A FRESH AIR KIT, SOLD SEPARATELY.**
 - **THE STOVE MUST BE ATTACHED TO THE STRUCTURE OF THE MOBILE HOME.**
 - **CAUTION: THE STRUCTURAL INTEGRITY OF THE MOBILE HOME FLOOR, WALL, CEILING AND ROOF MUST BE MAINTAINED.**
- Connect this stove only to a listed factory-built chimney for use with solid fuel or to a lined masonry chimney conforming to local and national building codes.
- If required, a supply of combustion air shall be provided to the room.
- Do not use makeshift materials or make any compromises when installing this cookstove.
- Any modification to the device that has not been approved in writing by the approval authority or the manufacturer violates CSA B365 (Canada) and ANSI NFPA 211 (USA) standards.

7.2 Regulations Governing the Installation of the Cookstove

In Canada, the CSA B365 Installation Code for Solid Fuel Burning Appliances and Equipment is to be followed in the absence of local code requirements. In the USA, the ANSI NFPA 211 Standard for Chimneys, Fireplaces, Vents and Solid Fuel-Burning Appliances is to be followed in the absence of local code requirements.

This cookstove must be connected to a chimney complying with the requirements for Type HT chimneys in the Standard for Factory-Built Chimneys for Residential Type and Building Heating Appliances, UL 103 HT and ULC S629 or to a code-approved masonry chimney with a flue liner.

7.3 Cookstove Positioning

Choose a location to avoid the chimney conflicting with floor joists, roof trusses, wall studs, water pipes, electric wires, and that allows the least possible deviations in the chimney. The location of the cookstove must allow enough room for its maintenance and the exhaust system.

This cookstove weighs approximately 575 lb (261 kg). To validate the installation of additional floor joist, consult the local building code.

7.4 Location of the Certification Label

Since the information given on the certification label affixed to the appliance always overrides the information published, in any other media (owner's manual, catalogues, flyers, magazines and web sites) it is important to refer to it in order to have a safe and compliant installation. In addition, important information about the stove can be found (model, serial number, etc.). The certification label is located on the back of the stove.

It is recommended to note the stove serial number on [page 5](#) of this manual since it will be needed to precisely identify the version of the appliance in the event replacement parts or technical assistance is required. It is also recommended to [register the warranty online](#).

8. Clearances to Combustible Material

The clearances given in this section have been established following test results in accordance with the procedures described in the standards ULC S627 (Canada) and UL 1482 (USA). When this cookstove is installed respecting the indicated minimum clearances or more, the flammable surfaces won't overheat during normal or even abnormal usage.

None of the cookstove parts or smoke pipe can be installed closer to the combustible materials than the minimum clearances indicated.

Fuel, solid or liquid, should not be located closer to combustibles than the minimum clearances given.

The clearances to the combustible walls can differ slightly between Canada and the United States and can also vary depending on the use of a single wall or double connector. Make sure to use the proper clearances for the location and the type of pipe.

The clearances of the appliance and the flue pipes must be met individually, meaning the appliance can not be installed closer to the combustible materials than the single or double wall pipe allows. To know the safe way to reduce clearances, see section [8.2 Clearances Reduction to the Walls and the Ceiling](#).

Refer to the following images and tables for minimum required clearances.

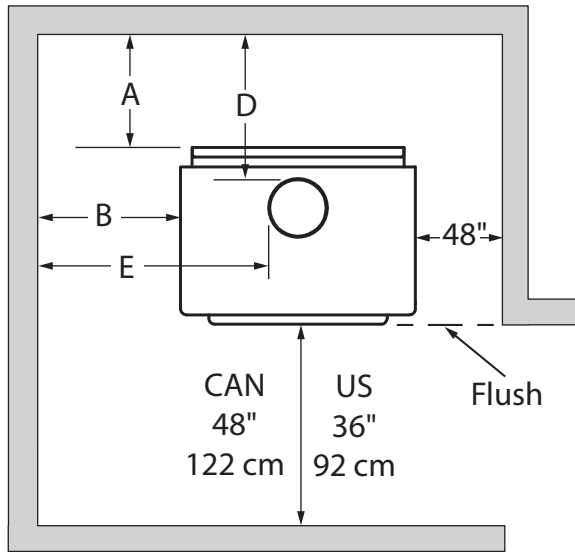

Figure 21: Clearances - Top

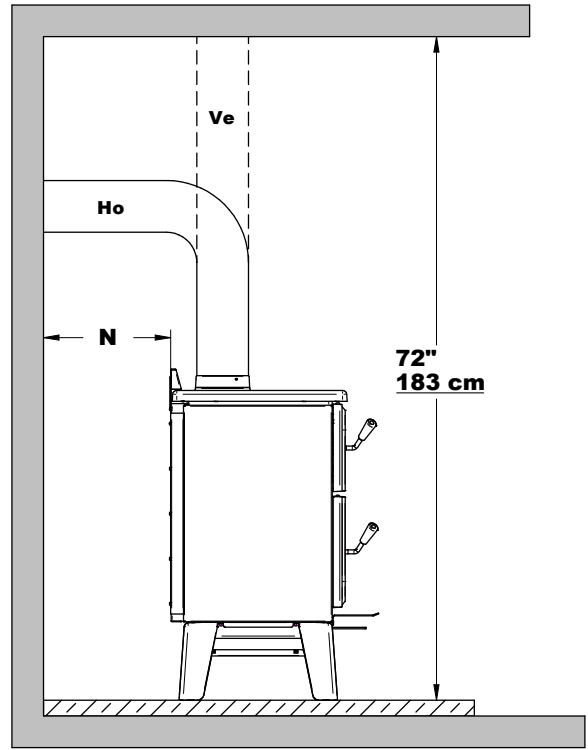

Figure 22: Clearances - Side

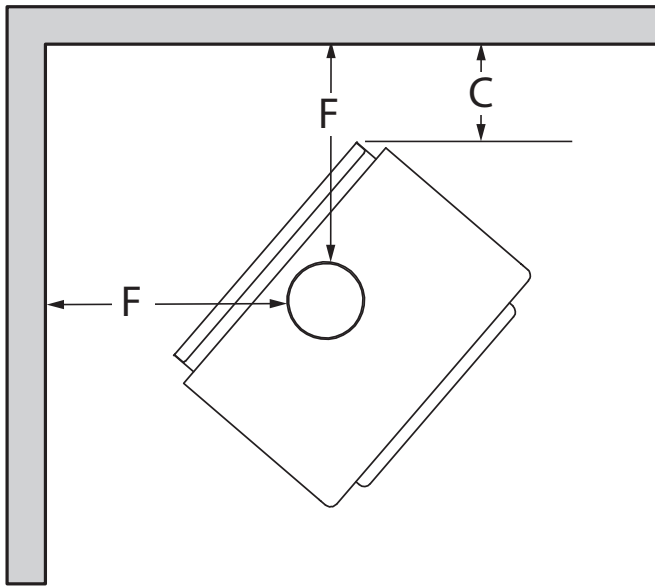

Figure 23: Clearances - Corner

	APPLIANCE CLEARANCES (INSTALLATION WITH SINGLE WALL PIPE CONNECTOR)	
	Canada	USA
A	15" (381 mm)	15" (381 mm)
B	15" (381 mm)	15" (381 mm)
C	7.5" (191 mm)	7.5" (191 mm)
L	72" (183 cm)	72" (183 cm)

	APPLIANCE CLEARANCES (INSTALLATION WITH DOUBLE WALL PIPE CONNECTOR)	
	Canada	USA
A	6" (152 mm)	6" (152 mm)
B	15" (381 mm)	15" (381 mm)
C	5" (127 mm)	5" (127 mm)
L	72" (183 cm)	72" (183 cm)

If the above clearances are met, then the distances measured from the flue outlet will be:

	DISTANCES ³ FROM PIPE CONNECTOR WITH SINGLE WALL PIPE CONNECTOR	
	Canada	USA
D	18" (457 mm)	18" (457 mm)
E	25" (635 mm)	25" (635 mm)
F	18" (457 mm)	18" (457 mm)

	DISTANCES ³ FROM PIPE CONNECTOR WITH DOUBLE WALL PIPE CONNECTOR	
	Canada	USA
D	9" (127 mm)	9" (127 mm)
E	24.75" (318 mm)	24.75" (318 mm)
F	15" (318 mm)	15" (318 mm)

³ The pipe distances listed in this table refer to the distances obtained when the stove is installed in accordance with the appliance clearances above mentioned.

8.1 Floor Protection

This stove is designed to prevent the floor from overheating. However, it must be placed on a non-flammable surface to protect the floor from hot embers that may fall during loading.

Any type of tile will require a continuous non combustible sheet beneath to prevent the possibility of embers falling through to the combustible floor if cracks or separation should occur in the finished surface. Check local codes for approved alternatives. No protection is required if the unit is installed on a non-combustible floor (ex: concrete).

	FLOOR PROTECTION	
	Canada	USA
G⁴	8" (203 mm)	N/A
H	8" (203 mm)	N/A
I	18" (457 mm) From door opening	16" (406 mm) From door opening
J	N/A	8" (203 mm)
K	42 7/8" (1089 mm)	39 7/8" (1013 mm)
N⁵	N/A	See note 5
S	48 3/8" (1229 mm)	38 3/8" (975 mm)
T	34 1/4" (870 mm)	27 1/8" (689 mm)
U	42 7/8" (1089 mm)	39 7/8" (1013 mm)
V	69 7/8" (1775 mm)	58 3/8" (1483 mm)

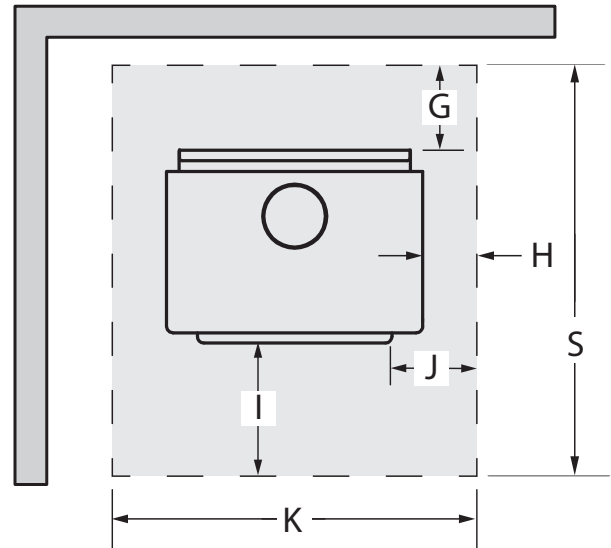

Figure 24: Floor protection

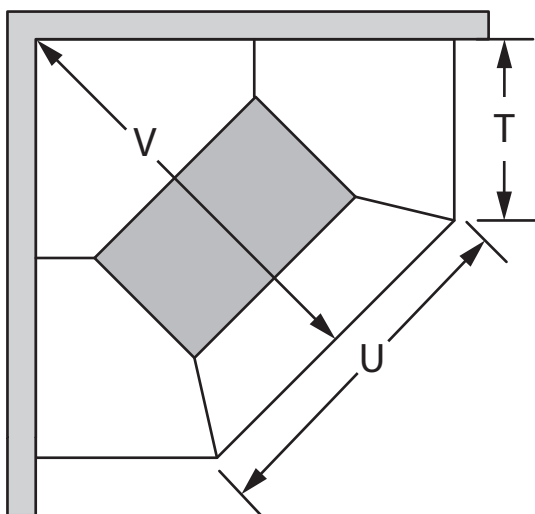

Figure 25: Clearances

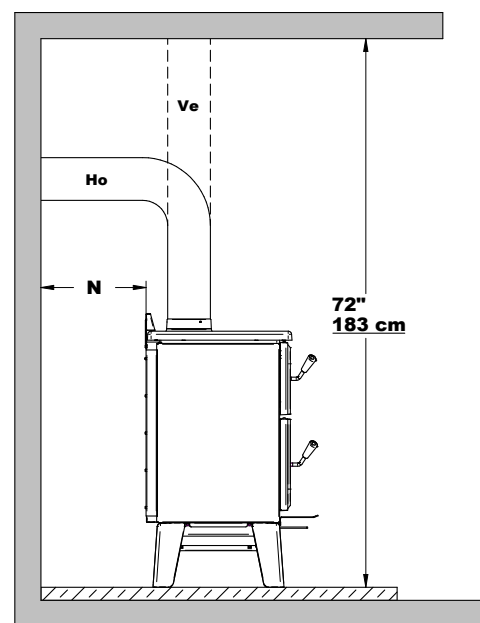
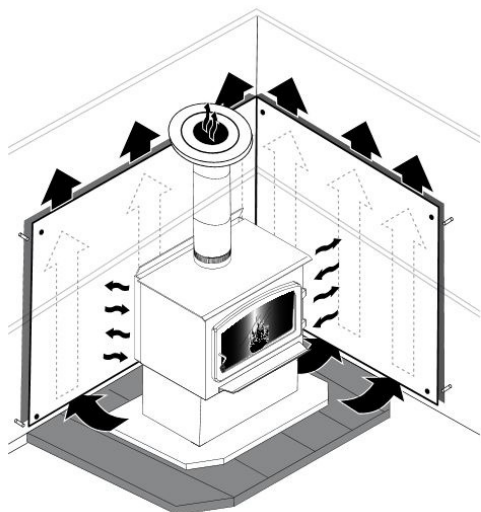

Figure 26: Clearances

⁴ The floor protection at the back of the stove is limited to the stove's required clearance if such clearance is smaller than 8 inches (203 mm).

⁵ Only required under the horizontal section (Ho) of the connector. Must exceed each side of the connector by at least 2 inches (51 mm).

8.2 Clearances Reduction to the Walls and the Ceiling



It is often desired to use as little space as possible when installing cookstove. To do this, it is possible to reduce the clearances safely and install the cookstove closer to the walls by permanently installing a heat shield between the cookstove and the flammable material. It is possible to obtain a heat shield that respects the dimensions requirements indicated in sections [8.3 Clearances for Shield Installation](#) and [8.3.2 Mobile home with heat shield](#). It is possible that additional sections or extensions are needed in order to reduce clearances easily and safely.

It is also possible to fabricate the heat shield but one must be careful since the rules for heat shield construction are sometimes complicated. Read and apply the instructions carefully. Some regions may have different regulations. Consult the local building code or contact the fire department for restrictions, inspection and installation requirements in the area.

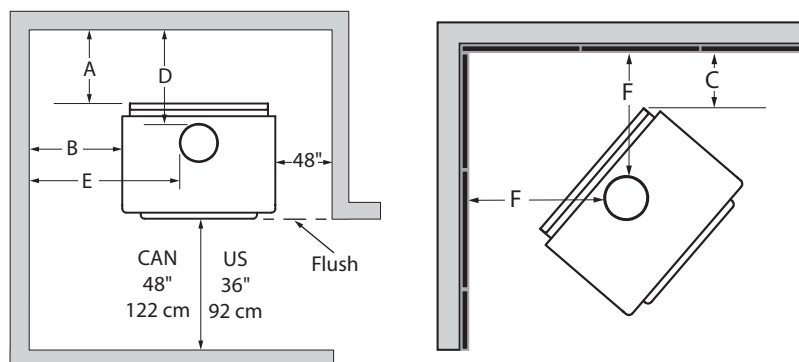

	APPLIANCE CLEARANCES WITH A SINGLE WALL PIPE CONNECTOR AND A HEAT SHIELD ⁶	
	Canada	USA
A	2.5" (64 mm)	2.5" (64 mm)
B	2.5" (64 mm)	2.5" (64 mm)
C	2.5" (64 mm)	2.5" (64 mm)

	DISTANCE FROM PIPE CONNECTOR WITH DOUBLE WALL PIPE CONNECTOR AND A HEAT SHIELD ⁶	
	Canada	USA
D	5.5" (140 mm)	5.5" (140 mm)
E	12.25" (311 mm)	12.25" (311 mm)
F	12.5" (318 mm)	12.5" (318 mm)

8.2.1 Heat Shield Construction Rules

- Adhesives used in the shield construction must not inflame or loose their adhesive properties at the temperature that potentially will be reached.
- The assembly hardware must allow for complete vertical ventilation.
- The assembly hardware that penetrates in the combustible material from the screen surface can only be used on the edges of the screen.

⁶ Note that to reduce the clearances as close as 6" from combustible material of an appliance using a single wall pipe, a certified heat shield must be used. Only in this situation, the same clearances as with a certified double wall pipe connector can be used.

Table 1 : Clearances Reduction Percentages Table

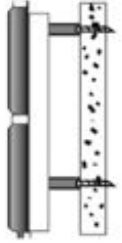
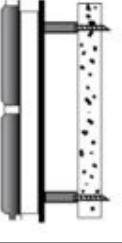
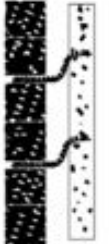
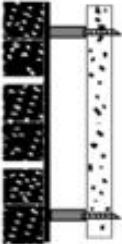
TYPE OF SHIELD	CLEARANCES MAY BE REDUCED BY THESE PERCENTAGES				
	SIDES AND REAR		TOP (CEILING)		
	CAN /USA (%)	USA MIN.	CAN /USA (%)	USA MIN.	
Sheet metal, a minimum of 24 gauge (0.61 mm) in thickness , spaced out at least 25 mm (1 in)* by non-combustible spacers	67	12 in	50	18 in	
Ceramic tiles, or equivalent non-combustible material, on non-combustible board spaced out at least 25 mm (1 in)* by non-combustible spacers	50	18 in	33	24 in	
Ceramic tiles, or equivalent non-combustible material, on non-combustible board, with a minimum of 24 gauge (0.61 mm) sheet metal backing spaced out at least 25 mm (1 in)* by non-combustible spacers	67	12 in	50	24 in	
Brick, spaced out at least 25 mm (1 in)* by non-combustible spacers	50	18 in	N/A	N/A	
Brick, with a minimum of 24 gauge (0.61 mm) sheet metal backing, spaced out at least 25 mm (1 in)* by non-combustible spacers	67	12 in	N/A	N/A	

* In Canada this space can be 7/8" (21 mm)

8.3 Clearances for Shield Installation

1	Minimum clearance between the top of the appliance and the unprotected ceiling	833 mm (32 13/16")
2	Shield extension above appliance	500 mm (20")
3	Minimum space behind the shield	USA 25 mm (1") Can. 21 mm (7/8")
4	Clearance at the bottom of the shield	USA 25 mm (1") Can. min. 25 mm (1") max 76 mm (3")
5	Minimum clearance from the top of the shield to the ceiling:	76 mm (3")
6	The assembly hardware must not be located at less than 200 mm (8") from the combustion chamber central axis.	
7	Shield edges clearances from the side and back walls for ceiling shield	75 mm (3")
8	Shield overtaking beyond the sides of the appliance	450 mm (18")

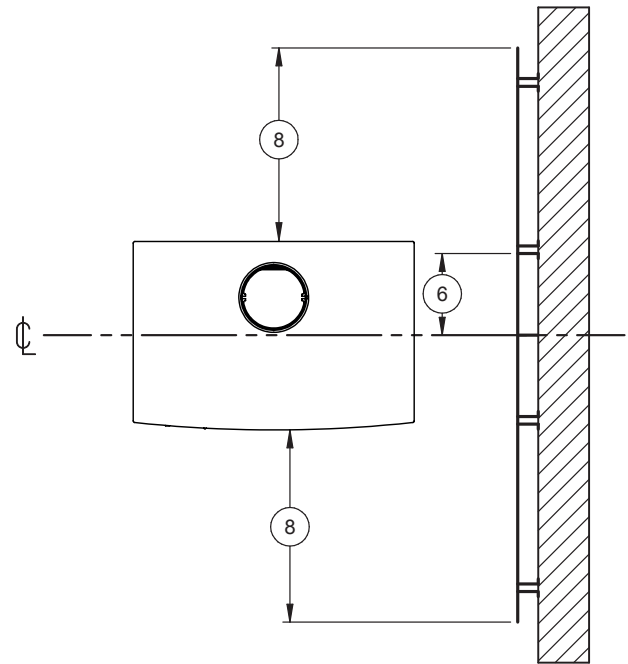

ENGLISH

Figure 27: Clearances with Heat Shield - Top

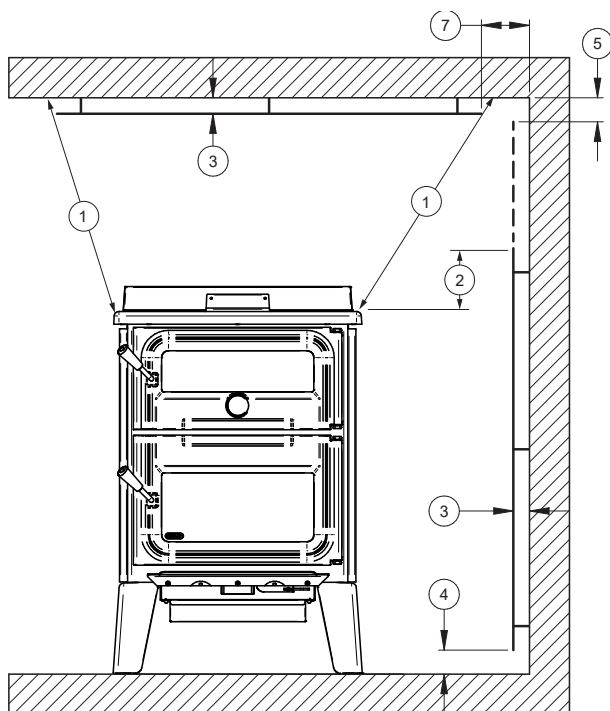

Figure 28: Clearances with Heat Shield - Face

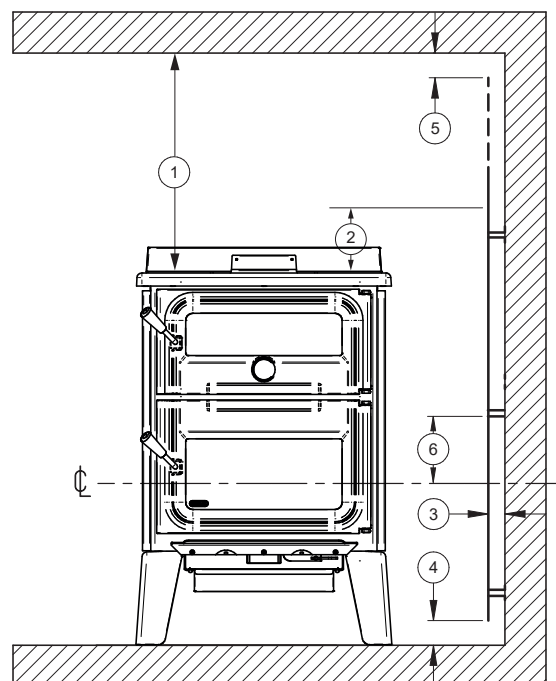

Figure 29: Clearances with Heat Shield - Face

8.3.1 Mobile Home

It is strictly **forbidden** to install a unit with a **single wall pipe** in a **mobile home**.

ENGLISH

	APPLIANCE CLEARANCES WITH DOUBLE WALL PIPE CONNECTOR	
	Canada	USA
A	6" (152 mm)	6" (152 mm)
B	15" (381 mm)	15" (381 mm)
C	5" (127 mm)	5" (127 mm)
L	84" (213 cm)	84" (213 cm)

	DISTANCES ⁷ FROM PIPE CONNECTOR WITH DOUBLE WALL PIPE CONNECTOR	
	Canada	USA
D	9" (229 mm)	9" (229 mm)
E	24.75" (629 mm)	24.75" (629 mm)
F	15" (381 mm)	15" (381 mm)

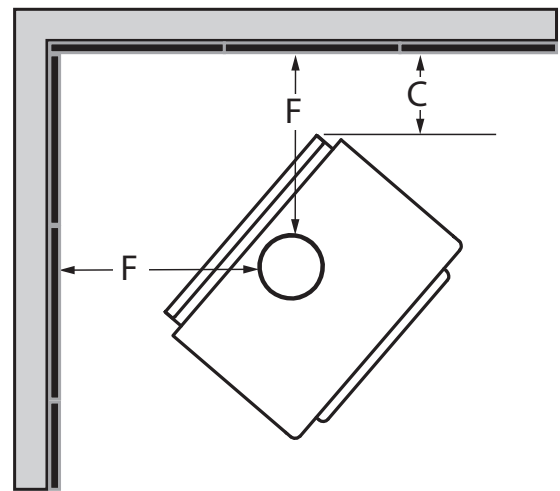
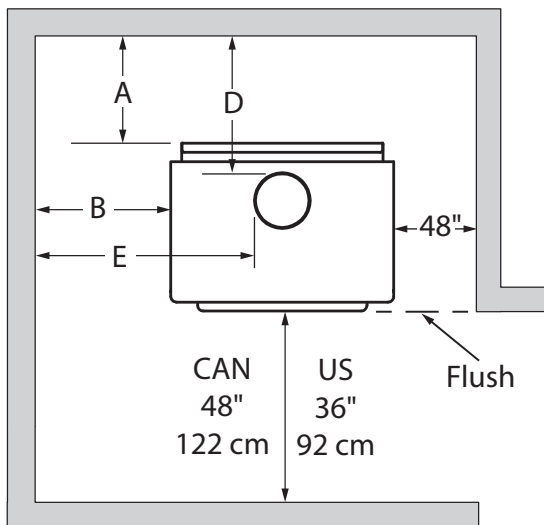

⁷ The pipe distances listed in this table refer to the distances obtained when the stove is installed in accordance with the appliance clearances above mentioned.

8.3.2 Mobile Home With Heat Shield

	APPLIANCE CLEARANCES WITH DOUBLE WALL PIPE CONNECTOR	
	Canada	USA
A	3" (76 mm)	3" (76 mm)
B	3" (76 mm)	3" (76 mm)
C	3" (76 mm)	3" (76 mm)

	DISTANCES FROM PIPE CONNECTOR WITH DOUBLE WALL PIPE CONNECTOR	
	Canada	USA
D	6.25" (159 mm)	6.25" (159 mm)
E	8.75" (222 mm)	8.75" (222 mm)
F	13" (330 mm)	13" (330 mm)

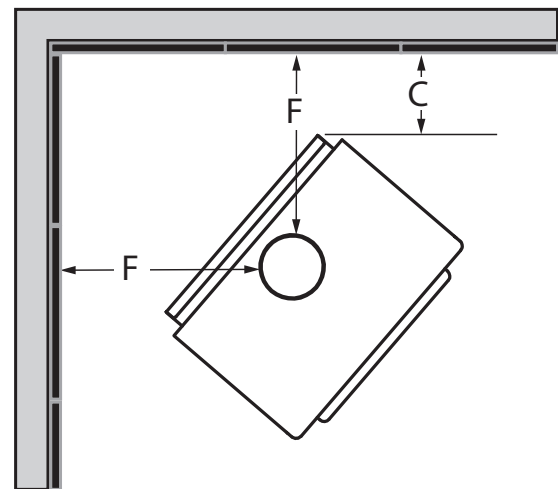
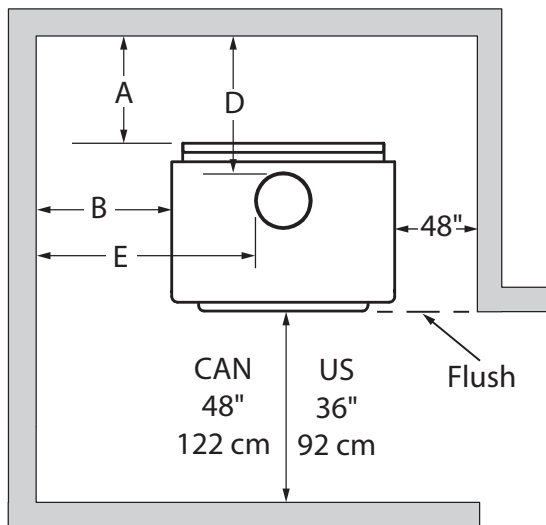

9. Evacuation System

9.1 General Information

The exhaust system, consisting of the chimney and the pipe that connects the cookstove to the chimney, acts as the engine that drives the wood heating system. Even the best appliance will not work as securely and adequately as expected if it is not connected to an adequate chimney.

The heat contained in the exhaust gas, which goes from the cookstove to the chimney connector, then to the chimney, is not lost heat. The chimney uses that heat to create the draft that draws the combustion air, keeps the smoke in the appliance and evacuates the gas securely toward open air. You can consider the heat contained in the exhaust gas as the combustible that the chimney uses to create the draft.

9.2 Suitable Chimneys

To be suitable, a prefabricated metal chimney must follow the standards UL 103 HT (USA) or ULC S629 (Canada). Furthermore, this wood burning cookstove has a performance and optimal efficiency when it is connected to a 6" chimney flue.

9.2.1 Factory-Built Metal Chimneys

These are sometimes referred to as ‘high temp’ chimneys because they have the specific characteristics to withstand temperatures that can be created by wood burning stoves. Factory-built chimneys are tested as a system with all the necessary components for installation. The instructions provided with the chimney by its manufacturer are the only reliable source of installation guidelines. To be safe and effective, the chimney must be installed exactly in accordance with the manufacturer’s instructions. Only components intended for the brand and model of chimney should be used. Never fabricate or substitute parts from other chimney brands. The chimney must be a type suitable for solid fuel.

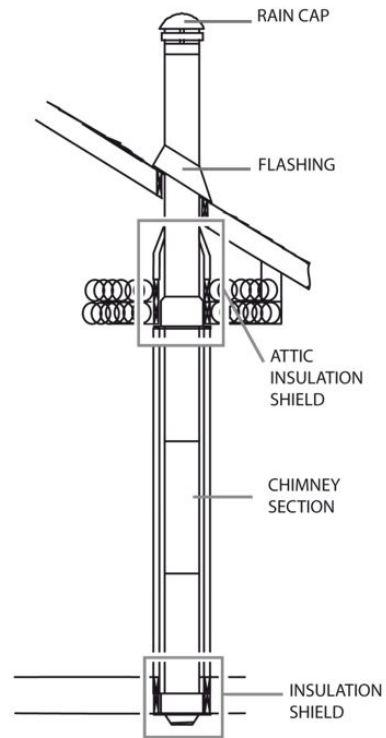

Figure 30: Standard installation

9.2.2 Factory-Built Metal Chimneys in Mobile Homes

For use in a mobile home, this stove is to be connected to a 6" double wall factory built chimney pipe conforming to ULC-S629 or UL 103HT standards for 650°C Factory-built chimney. The total length of the flue system should be at least 12 feet including elbows, from the top of the stove.

To maintain an effective vapour barrier, insulation and waterproof at the chimney and outside flue pipe, a roof flashing must be installed and sealed with silicone adhesive.

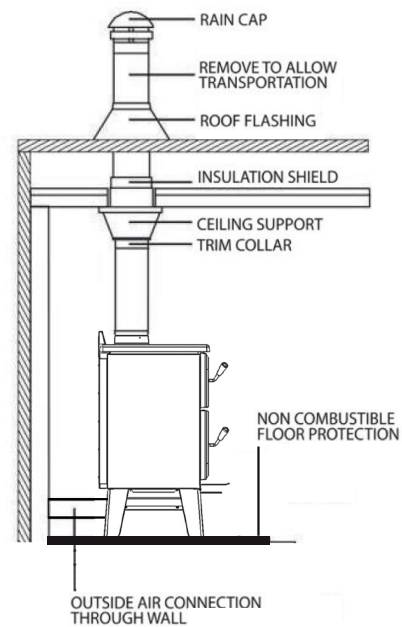

Figure 31: Mobile home installation

9.2.3 Masonry Chimneys

The stove may also be connected to a masonry chimney, provided the chimney complies with the construction rules found in the building code enforced locally. The chimney must have either a clay liner or a suitably listed stainless steel liner. If the masonry chimney has a square or rectangular liner that is larger in cross-sectional area than a round 6" flue, it should be relined with a suitably listed 6" stainless steel liner. Do not downsize the flue to less than 6" unless the venting system is straight and exceeds 25 feet in height. When passing through a combustible wall, the use of an insulated listed thimble is required.

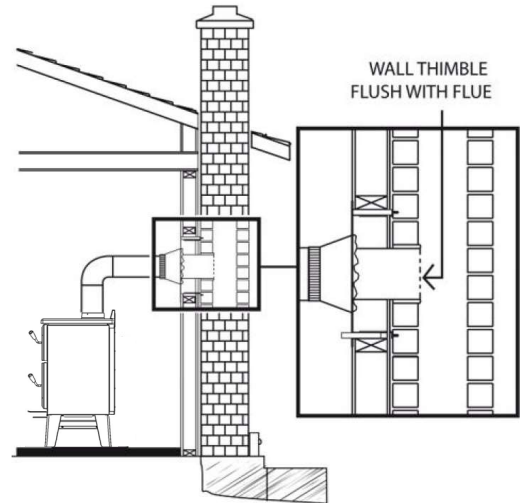

Figure 32: Masonry hearth installation

9.3 Minimum Chimney Height

The top of the chimney should be tall enough to be above the air turbulence caused when wind blows against the house and its roof. The chimney must extend at least 3 ft. (1 m) above the highest point of contact with the roof, and at least 2 ft. (60 cm) higher than any roof line or obstacle within a horizontal distance of 10 ft. (3 m).

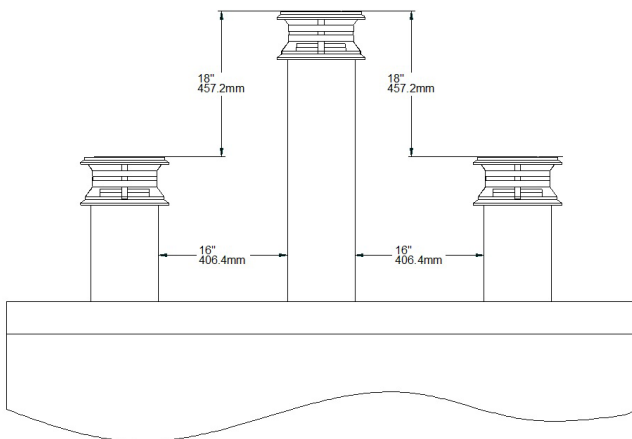

Figure 33: Flat roof

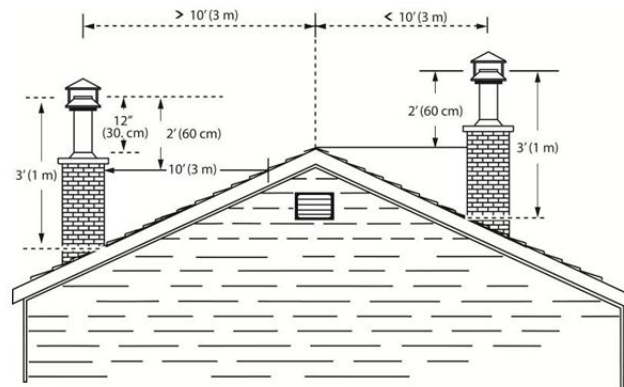

Figure 34: Sloping roof

9.4 Chimney Location

Because the venting system is the engine that drives the wood heating system, it must have the right characteristics. The signs of bad system design are cold back drafting when there is no fire in the stove, slow kindling of new fires, and smoke roll-out when the door is opened for loading. There are two guidelines to follow. First, the chimney should be installed up through the heated space of the house, not outside up on the wall. Second, the chimney should ideally go through the highest heated space of the building or near the highest heated space.

Venting systems that rise straight up from the stove flue collar provide the best performance. Chimneys that rise inside the warm space of the house tend to provide a small amount of draft even when there is no fire burning. This means that when a fire is lit, the smoke goes up the chimney and strong draft build quickly as the chimney flue warms up. Although they are common in North America, chimneys that exit a house wall and run up outside can cause problems.

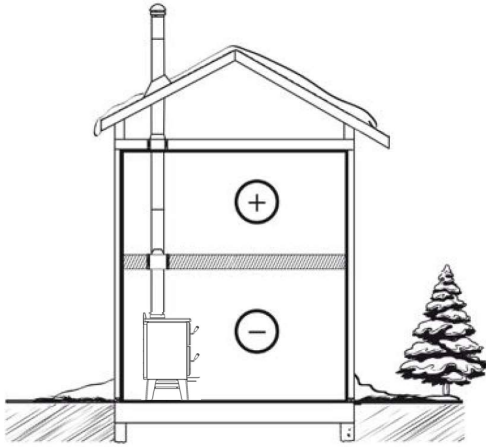

Figure 35: Good System Design

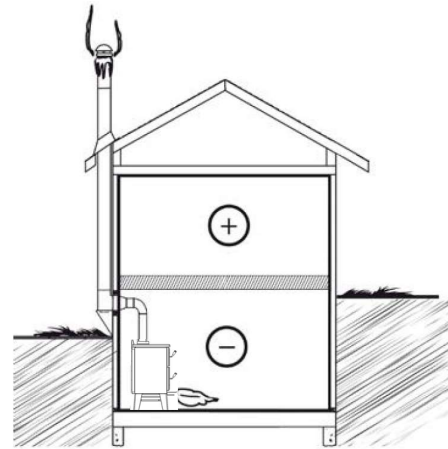
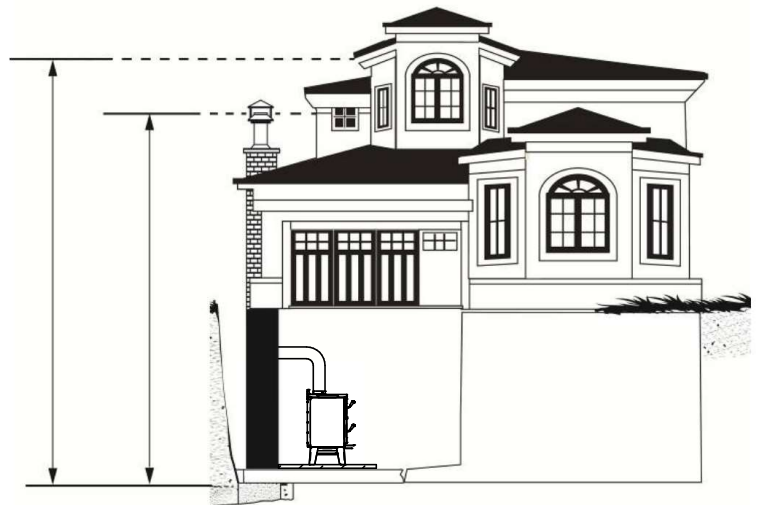

Figure 36: Acceptable System Design

When it is cold outside, the warm air in the house is buoyant so it tends to rise. This creates a slight pressure difference in the house. Called 'stack effect', it produces a slightly negative pressure in the lower part of the house (compared to the outside) and a slightly positive pressure zone in the high part of the house. If there is no fire burning in a heater connected to a chimney that is shorter than the warm space inside the house, the slight negative pressure in the lower part of the house will compete against the desired upward flow in the chimney. This occurs for the two following reasons:

First, the chimney runs up the outside of the house, so the air in it is colder and denser than the warm air in the house. And second, the chimney is shorter than the heated space of the house, meaning the negative pressure in the lower part of the house will draw cold air down the chimney, through the stove and into the room. Even the finest stove will not work well when connected to this chimney.



10. Installing the Chimney Connector

The chimney connector is the single or double wall pipe installed between the stove flue collar and the chimney breech. Single wall pipe components are available from most hardware and building supply stores. These components are not usually tested to a particular standard and certified as compliant. Therefore, a list of rules found in solid fuel installation codes apply to the installation of a single wallpipe.

Double wall chimney connectors are tested and certified. The rules for double wall pipe are found in the manufacturer's installation instructions. These rules will be very different than those for single wall.

10.1 Installation of Single Wall Chimney Connector

The chimney connector assembly has been called 'the weak link' in the safety of wood heating systems because failure to install the connector properly (which has been common in the past) can result in house fires.

The best flue pipe assembly is one that rises straight up from the stove to the base of the chimney with no elbows. Straight assemblies are less likely to cause problems like smoke rollout when the door is opened for loading. They are also more stable and easier to maintain than assemblies with elbows. Horizontal runs of flue pipe should be avoided where possible because they reduce chimney draft.

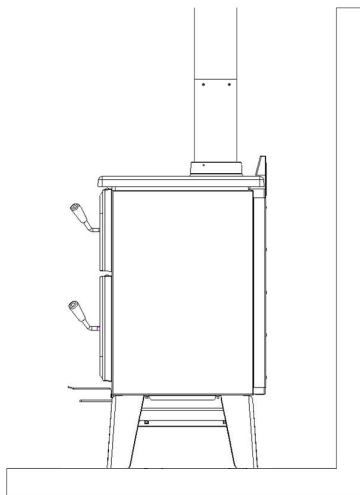

Figure 37: Best

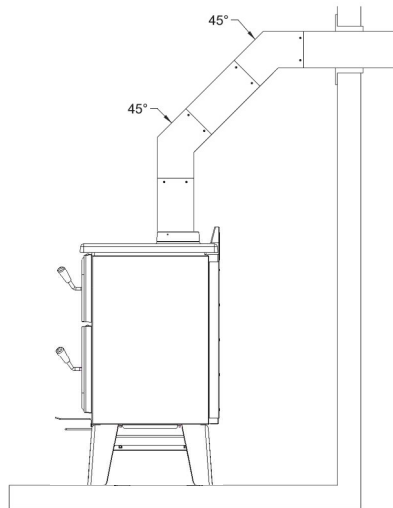

Figure 38: Acceptable

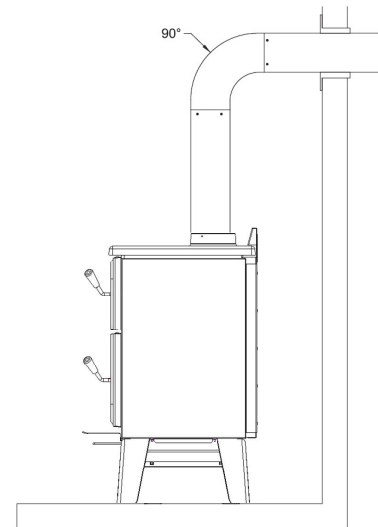

Figure 39: Avoid

The rules below are based on those found in the CSA B365 installation code. Please carefully follow these installation instruction rules, or those enforced by the local code.

- Maximum overall length of horizontal pipe: 10 ft. (3 m) including elbows.
- Minimum clearance from combustible material: 18" (450 mm). The minimum clearance may be reduced by 50 percent to 9" (225 mm) if suitable shielding is installed either on the pipe or on the combustible surface.

- The assembly should be as short and direct as possible between the stove and chimney. The use of two 45 degree elbows is often preferable to a single 90 degree elbow because less turbulence is created in the exhaust flow and they result in less horizontal run.
- The minimum overall height of the chimney system, measured from the stove top to the exterior termination cap of the chimney should be at least 12 ft. (3.66 m). A chimney which is too short may lack the “tunnel effect” required to obtain a proper draft.
- Maximum number of 90-degree elbows: 2.
- Maximum unsupported horizontal length: 3 ft. (1 m).
- Galvanized flue pipes must not be used because the coatings vaporize at high temperatures and release dangerous gases. Use black painted flue pipes.
- Flue pipes must be at least 24 gauge in thickness.
- Flue pipe joints should overlap 1 ¼" (30 mm).
- Each joint in the assembly must be fastened with at least three screws.
- The assembly must make allowance for expansion: elbows in assemblies allow for expansion; straight assemblies should include an inspection wrap with one end unfastened, or a telescopic section.
- Minimum upward slope towards the chimney: ¼ in/ft. (20 mm/m).
- One end of the assembly must be securely fastened to the flue collar with 3 sheet metal screws and the other end securely fastened to the chimney.
- There must be provision for cleaning of the pipes, either through a clean out or by removal of the pipe assembly. Removal of the assembly should not require that the stove be moved.
- The male ends of the sections must be oriented towards the appliance so that falling dust and condensation stay inside the pipe.
- A flue pipe must never pass through a combustible floor or ceiling or through an attic, roof space, closet or concealed space. Where passage through a wall or partition of combustible construction is desired, the installation shall conform to CAN/CSA-B365, Installation Code for Solid-Fuel-Burning Appliances and Equipment.
- A straight up connector assembly needs either a telescopic length or an inspection wrap (pipe coupler) to allow it to be assembled and disassembled without moving the stove.
- A straight flue pipe assembly offers the least restriction to gas flow and results in a stronger draft. Straight assemblies also need less maintenance because there are no corners to collect creosote.
- The chimney connector must be clean and in good condition.

10.2 Installation of Double wall Chimney Connector



Important!

A double wall chimney connector can be installed only with the universal connector PL36899 supplied with the cookstove and a vented double wall stove adaptor.

To install a double wall connector on the appliance, the universal connector supplied with the stove must be installed as shown on the picture bellow.

Insert the connector **(A)** to the spigot and fix it with the 3 screws **(B)** included with the appliance.

A vortex double wall connector, with its vented stove adaptor (VOD0290), is recommended for this type of installation. Consult www.drolet.ca for more details. Other brands of double wall connectors are adequate as long as they offer the option of a vented double wall stove adaptor.

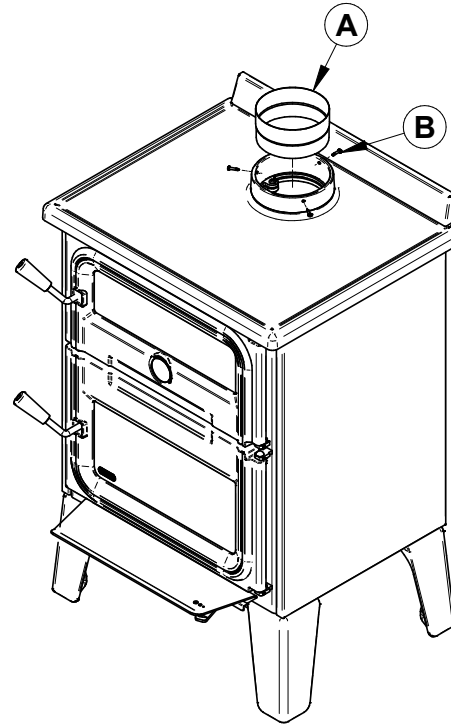

Figure 40: Universal connector PL36899

11. Combustion Air

For the cookstove draft to work correctly, the room must have an outside or fresh air inlet, with a minimum of 5" diameter, from the house exterior to the room, that is at least sufficient to replenish the volume of air that comes out of the chimney flue. In well insulated houses an air inlet must be fitted through the outer wall that is not exposed to the prevailing winds, depending on the surrounding conditions of the house. If a vent is installed, it must be fitted in such a way that it cannot be blocked. A fresh air intake register with a airtight damper may be installed to help prevent any uncomfortable air draft.

When the cookstove and the chimney are completely cold, it may be necessary before starting up to provide an external air supply by opening a door or a window for a short period. A house constructed or renovated in a waterproof manner is prone to not having the air exchange required for the proper functioning of a wood heating appliance.

In that case, avoid, during startups, to use appliances that evacuate air outside of the house, such as:

- Cookstove hood
- Bathroom vent
- Air exchange system
- Ventilated central vacuum cleaner
- Dryer

The supply of fresh combustion air can be done in several ways, provided they comply with CSA B365 and NFPA211.

In Canada, wood stoves are not required to have a combustion air supply from outside, except for mobile homes. Research has shown that outside air supply do not compensate for the depressurization of the house and may not be sufficient to provide a supply of combustion air in windy weather. However, to reduce the risks against smoke spillage due to house depressurization, a carbon monoxide (CO) detector is required in the room where the stove is installed. The CO detector will provide warning if for any reason the wood stove fails to function correctly.

11.1 Mobile home

This stove is 'mobile home approved'. It must therefore have a supply of combustion air from outdoors. The air intake must not draw air from the attic, from the basement, from a garage or any enclosed space. Air must be drawn from a ventilated crawl space under the floor or directly from outside. Install a flexible or rigid, insulated pipe (HVAC type, must comply to ULC S110 and/or UL 181, Class 0 or Class 1) to the fresh air intake.

Where a mobile home has been converted to a standard house by mounting it on a permanent basement foundation, the supply of outdoor air is not required.

11.2 Conventional House

The safest and most reliable supply of combustion air for a wood stove is from the room in which it is installed. Room air is already preheated so it will not chill the fire, and its availability is not affected by wind pressures on the house. Contrary to commonly expressed concerns, almost all tightly sealed new houses have enough natural leakage to provide the small amount of air needed by the stove. The only case in which the wood stove may not have adequate access to combustion air is if the operation of a powerful exhaust device (such as a kitchen range exhaust) causes the pressure in the house to become negative relative to outdoors.

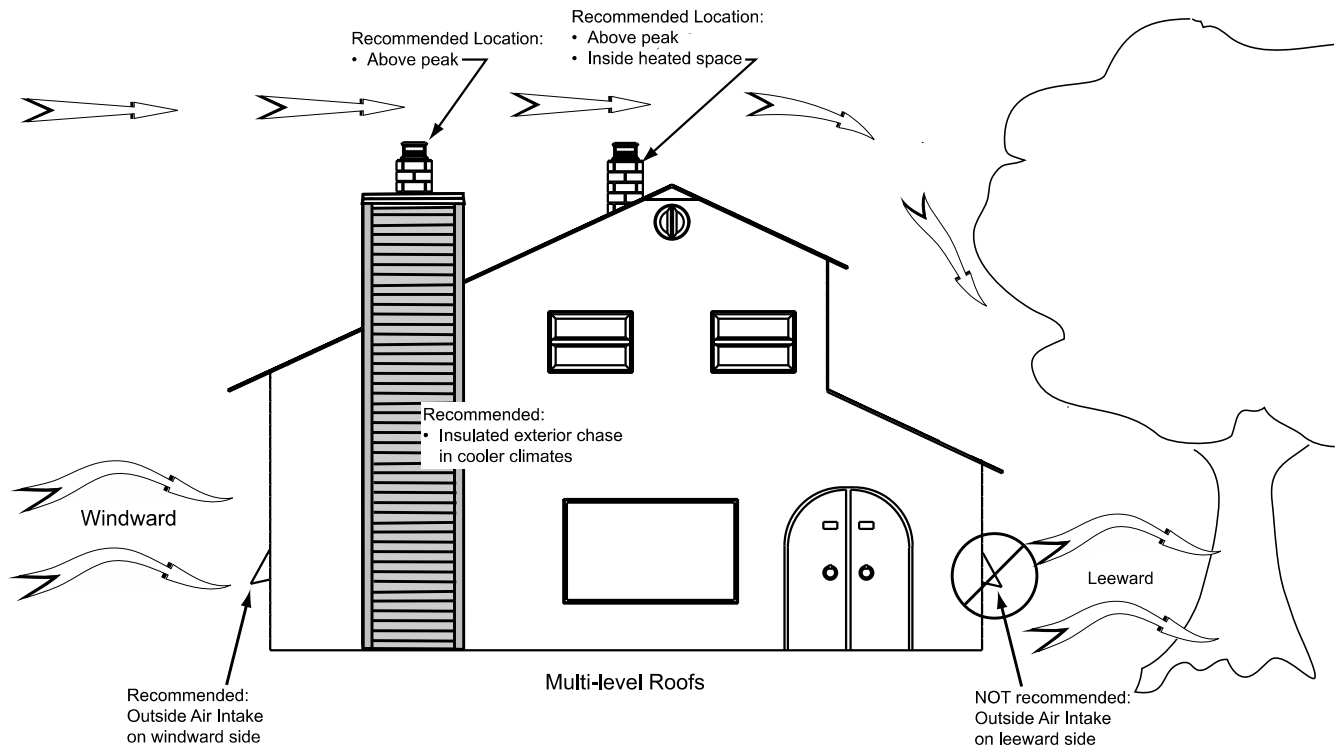

Figure 41: Air supply in conventional houses

If an air intake is installed through the wall of the house, its pressure can vary during windy weather. If there are changes in wood stove performance in windy weather, and in particular if smoke puffs from the stove, the air duct should be disconnected from the stove to determine if it is the cause of the problem. In some windy conditions, negative pressure at the duct weather hood outside the house wall may draw hot exhaust gases from the stove backwards through the duct to outdoors. Check the outdoor air duct for soot deposits when the full system is cleaned and inspected at least once each year.

12. Troubleshooting

PROBLEM	POSSIBLE CAUSES	SOLUTION
Oven window or combustion chamber's window blackening.	<ul style="list-style-type: none"> • Draft too low • Bad air intake adjustment • Too much combustible in the cookstove. • Wood with a high rate of relative humidity > 20-25% • Unregulated combustion. 	<ul style="list-style-type: none"> • Check that all the pipes are clean. • Modify the chimney: increase the height or check surroundings. • Reduce the quantity of combustible in the combustion chamber. • Dry the wood longer.
Irregular draw.	<ul style="list-style-type: none"> • Inadequate or dirty chimney. • Dirt in the combustion chamber or in the cookstove. • Strong winds 	<ul style="list-style-type: none"> • Sweep the chimney or have it clean by a professional. • Clean the cookstove. • Relocate chimney or fresh air intake.
Black smoke leaking out of the cookstove.	<ul style="list-style-type: none"> • Ignition with green wood. • Smoke pipe obstructed. 	<ul style="list-style-type: none"> • Ignite the cookstove with suitable combustible. • Ask for professional qualified assistance.
Smoke coming out of the cookstove.	<ul style="list-style-type: none"> • Combustion chamber's door open while the cookstove is heating. • Insufficient draw • Bad adjustments of the air inlets during startup. • The cookstove must be cleaned. 	<ul style="list-style-type: none"> • Check the door closing and the tightness of the gaskets. • Check the chimney system. • Eliminate or reduce to minimum the deviations and horizontal lengths in the chimney. • Check all the chimney sections as well as its height on the outside. • Ask for a chimney inspection by a certified technician. • Regularly clean the cookstove as indicated.

13. Parts List

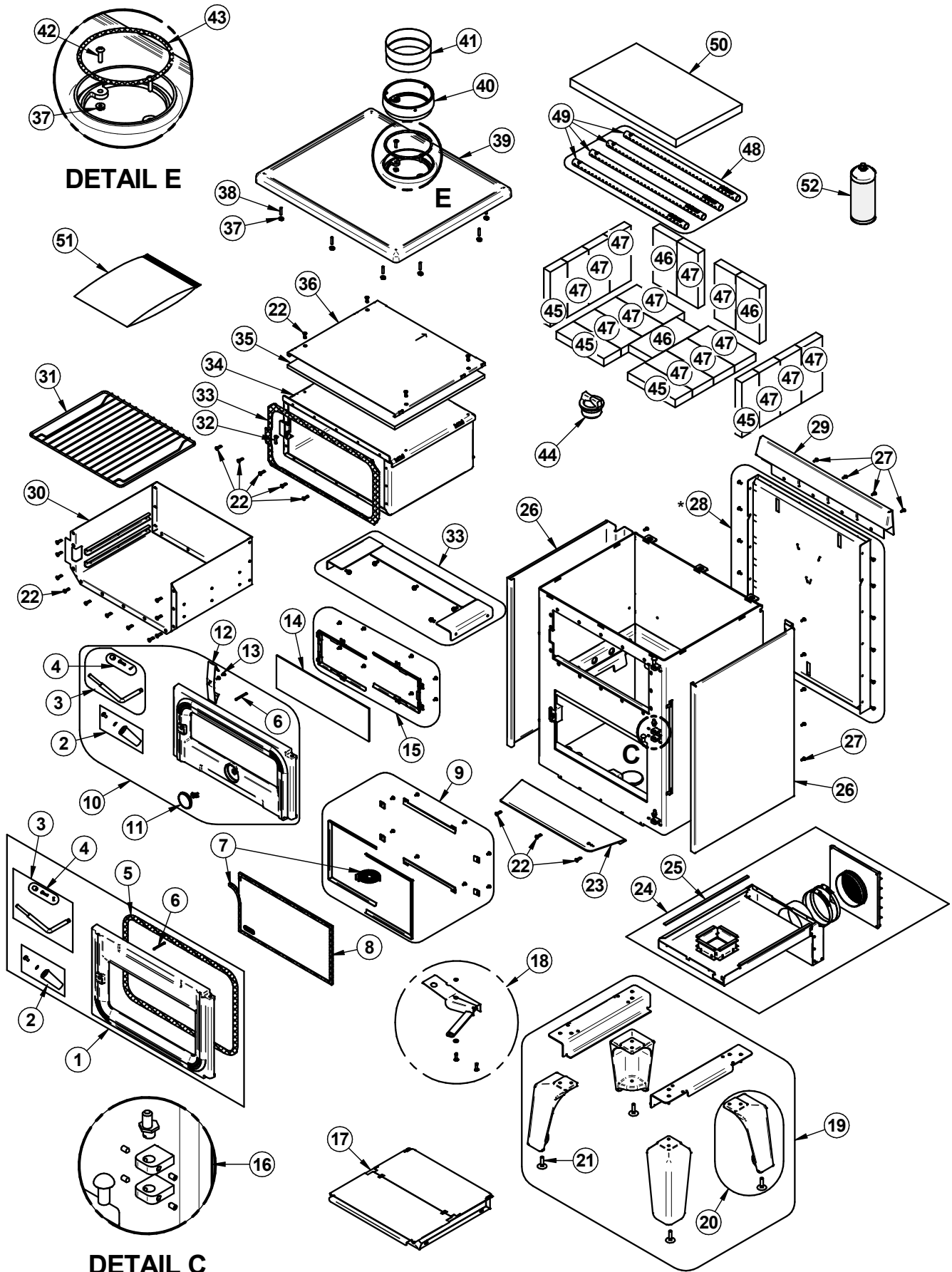

ENGLISH

IMPORTANT: THIS IS DATED INFORMATION. When requesting service or replacement parts for your unit, please provide the model number and the serial number. We reserve the right to change parts due to technology upgrade or availability. Contact an authorized dealer to obtain any of these parts. Never use substitute materials. Use of non-approved parts can result in poor performance and safety hazards.

#	Item	Description	Qty
1	SE24360	OVEN BISTRO DOOR ASSEMBLY	1
2	SE31234	BISTRO HANDLE KIT	1
3	SE74531	BISTRO DOOR HANDLE ROD KIT	2
4	AC09185	DOOR LATCH KIT	2
5	AC06500	SILICONE AND 5/8" X 8' BLACK DOOR GASKET KIT	1
6	31243	PLAIN FINISH STEEL SLOTTED SPRING PIN 3/16"Ø X 2"L	2
7	AC06400	3/4" X 6' FLAT BLACK SELF-ADHESIVE GLASS GASKET	2
8	SE74520	17 5/8" X 9 9/16" GLASS WITH GASKET	1
9	SE74521	BISTRO GLASS RETAINER KIT	1
10	SE24359	OVEN BISTRO DOOR ASSEMBLY	1
11	31227	COOK STOVE THERMOMETER	1
12	PL74524	SHOCK-ABSORBER	1
13	30124	SCREW #8 - 32 X 5/16" TRUSS QUADREX ZINC	2
14	SE74522	17 5/8" X 5 1/2" GLASS WITH GASKET	1
15	SE74523	BISTRO OVEN GLASS RETAINER KIT	1
16	SE31226	COMPLETE HINGE PIN KIT	1
17	SE65867	ASH PAN ASSEMBLY	1
18	SE74542	AIR CONTROL DAMPER ASSEMBLY	1
19	SE74512	SUPPORT AND LEGS KIT	1
20	SE24362	LEG WITH ELEVATOR BOLT	1
21	30050	LEVELING BOLT 3/8-16 X 1 1/2"	4
22	30507	BLACK TORX SCREW WITH FLAT HEAD TYPE F 1/4-20 X 3/4"	17
23	PL74533	BISTRO ASH SHELF	1
24	AC01211	5"Ø FRESH AIR INTAKE KIT FOR WOOD STOVE ON LEGS	1
25	AC06810	SELF ADHESIVE BLACK GASKET KIT 1/8" X 3/8" X 6'	1
26	PL74516	DECORATIVE SIDE	2
27	30154	BLACK SCREW #10 X 5/8" QUADREX #2 TYPE A	14
28	SE74514	REAR HEAT SHIELD ASSEMBLY	1
29	PL74525	BACK-SPLASH	1
30	SE74507	OVEN INTERIOR	1
31	31224	BISTRO GRILL COOK STOVE	1
32	30506	SCREW PAN TORX TYPE F 1/4-20 X 1" BLACK	1
33	AC06950	SELF-ADHESIVE GASKET 1" X 1/8" X 9'	1
34	SE74504	OVEN ASSEMBLY	1

#	Item	Description	Qty
35	21635	17" X 20 5/16" X 1/2" INSULATION	1
36	PL74534	INSULATING PROTECTIVE	1
37	30782	HEX FLANGE NUT SERRATED 1/4-20 STAINLESS 18-8	12
38	30128	1/4"-20 X 1 1/4" SOCKET SET SCREW	10
39	SE24361	TOP ASSEMBLY	1
40	PL24365	CAST IRON SPIGOT PAINTED	1
41	PL36899	DOUBLE WALL ADAPTOR	1
42	30024	1/4-20 X 1" MECHANICAL SCREW PAN QUADREX ZINC	2
43	AC06815	BLACK GASKET AND SILICONE KIT 3/16" X 5'	1
44	24096	ROUND CAST IRON ASH PLUG	1
45	29007	3 1/4" X 9" X 1 1/4" REFRACTORY BRICK	3
46	29010	4 1/2" X 9" X 1 1/4" REFRACTORY BRICK	4
47	29015	4" X 9" X 1 1/4" REFRACTORY BRICK	14
48	SE65514	SECONDARY AIR TUBE KIT	1
49	PL65514	SECONDARY AIR TUBE	4
50	21388	20" X 12 1/2" X 1 1/4" VERMICULITE BAFFLE	1
51	SE46251	BISTRO INSTRUCTION MANUAL KIT	1
52	AC05959	METALLIC BLACK STOVE PAINT - 342 g (12oz) AEROSOL	1

BISTRO COOKING STOVE LIMITED LIFETIME WARRANTY

The warranty of the manufacturer extends only to the original retail purchaser and is not transferable. This warranty covers brand new products only, which have not been altered, modified nor repaired since shipment from factory. Proof of purchase (dated bill of sale), model name and serial number must be supplied when making any warranty claim to your DROLET dealer.

This warranty applies to normal residential use only. Damages caused by misuse, abuse, improper installation, lack of maintenance, over firing, negligence or accident during transportation, power failures, downdrafts, venting problems or under-estimated heating area are not covered by this warranty. The recommended heated area for a given appliance is defined by the manufacturer as its capacity to maintain a minimum acceptable temperature in the designated area in case of a power failure.

This warranty does not cover any scratch, corrosion, distortion, or discoloration. Any defect or damage caused by the use of unauthorized or other than original parts voids this warranty. An authorized qualified technician must perform the installation in accordance with the instructions supplied with this product and all local and national building codes. Any service call related to an improper installation is not covered by this warranty.

The manufacturer may require that defective products be returned or that digital pictures be provided to support the claim. Returned products are to be shipped prepaid to the manufacturer for investigation. Transportation fees to ship the product back to the purchaser will be paid by the manufacturer. All parts covered by this warranty are limited according to the table below.

The manufacturer, at its discretion, may decide to repair or replace any part or unit after inspection and investigation of the defect. The manufacturer may, at its discretion, fully discharge all obligations with respect to this warranty by refunding the wholesale price of any warranted but defective parts. The manufacturer shall, in no event, be responsible for any uncommon, indirect, consequential damages of any nature, which are in excess of the original purchase price of the product. A one-time replacement limit applies to all parts benefiting from lifetime coverage. This warranty applies to products purchased after March 1st, 2015.

DESCRIPTION	WARRANTY APPLICATION*	
	PARTS	LABOUR
Combustion chamber (welds only) and cast iron door frame.	Lifetime	N/A
Surrounds, ash drawer, trims (extrusions), and convector air-mate.	5 years	N/A
Removable stainless steel combustion chamber components, deflectors, and supports.	5 years	N/A
Glass retainers, handle assembly, and air control mechanism.	3 years	N/A
Carbon steel combustion chamber components.	2 years	N/A
Paint (peeling**), plating (defective manufacture**), ceramic glass (thermal breakage only**), gaskets, insulation, and oven thermometer.	1 year	N/A
Firebricks, vermiculite combustion chamber components, oven mitt, and cooking accessories.	N/A	N/A
All parts replaced under the warranty.	90 days	N/A

**Subject to limitations above. **Picture required.*

Shall your unit or a components be defective, contact immediately your **DROLET** dealer. To accelerate processing of your warranty claim, make sure to have on hand the following information when calling:

- Your name, address and telephone number;
- Bill of sale and dealer's name;
- Installation configuration;
- Serial number and model name as indicated on the nameplate fixed to the back of your unit;
- Nature of the defect and any relevant information.

Before shipping your unit or defective component to our plant, you must obtain an Authorization Number from your DROLET dealer. Any merchandise shipped to our plant without authorization will be refused automatically and returned to sender.

This document is available for free download on the manufacturer's website. It is a copyrighted document. Resale is strictly prohibited. The manufacturer may update this document from time to time and cannot be responsible for problems, injuries, or damages arising out of the use of information contained in any document obtained from unauthorized sources.



Stove Builder International inc.
250, rue de Copenhague,
St-Augustin-de-Desmaures (Québec) Canada
G3A 2H3
418-908-8002
www.drolet.ca/en/
tech@sbi-international.com