

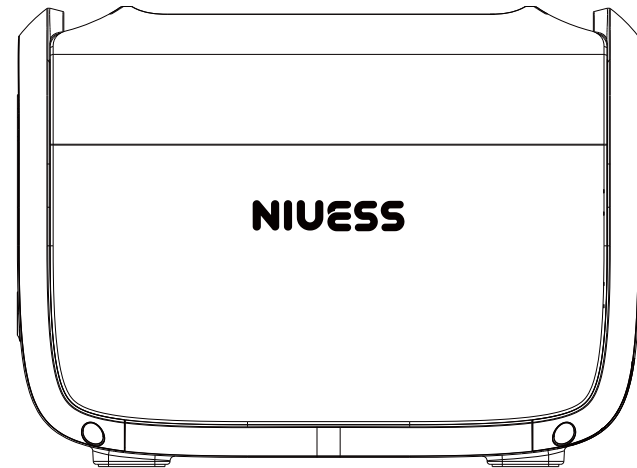

NIUESS

Usage/Maintenance/Safety User Manual

NE-1200 **120V 60Hz**



REPOWER TIMES TECHNOLOGY CO., LTD.

Add: Babai industrial park, Baihuayuan road,
Guangming district, Shenzhen, CN

Tel: +86 - 755 - 26703611

Website: www.niuess.com

Service line: 4000-188-189

Glossary

The following terms are used in this document to indicate various levels of potential harmd that may be caused by improper operation.

NOTICE

The instructions,if not properly followed, may result in property damage and minor injury .

CAUTION

The instructions, if not properly followed, may result in property damage and serious physical damage injury.

WARNING

The instructions, if not properly followed, may result in property damage, major accident and serious injury.

Warning 1

- 1.Please keep dry and keep away from fire.
- 2.Do not disassemble, puncture, perform irregular operations on the exposed ports or strongly impact the product.
- 3.Please recycle and dispose of the product according to local laws.
- 4.Pay attention to safety when carrying, do not hit your feet.
- 5.For children or people with limited intelligence, be careful to use it under the protection of a supervisor.

Warning 2

Read the ENTIRE user manual to be familiar with the features of this product before operating.Failure to operate the product correctly may result in damage to the product or personal property and cause serious injury. NIUESS will not assume any legal responsibility.

Do not use parts not provided or recommended by NIUESS, and must strictly follow the instructions of NIUESS to install and use the product, otherwise you will not be able to obtain free after-sales service from NIUESS.

This guidance document contains instructions for safety, operation, and maintenance. It is important to read the user manual carefully before assembly, setup and use.

Product Safety Guidelines

⚠ Warning

Improper use may result in fire, property damage or personal injury. Make sure to use the product according to the following safety rules and guidelines.

Product Use:

1. Do not let the product come into contact with any liquid, do not immerse the product in water or get it wet. Do not use the machine in the rain or wet environment, otherwise the battery will spontaneously ignite, and may even cause an explosion.
2. Never use NON-NIUSS parts. Go to <http://www.niuess.com> to purchase new parts. NIUESS takes no responsibilities for any damages caused by the use of Non-NIUSS parts.
3. Never install or remove other modules from the machine when it is turned on. Do Not plug or unplug other modules when the power of the product is turned on, otherwise the power interface may be damaged.
4. The product should be used at an ambient temperature between -20°C and 50°C. If the temperature is too high (above 50°C), the battery may catch fire or even explode. If the temperature is too low (below - 20°C), the performance of the product will be seriously reduced, and it may

not meet the normal use requirements. It can be used normally after returning to normal temperature.

5. DO NOT use the batteries in strong electrostatic or electromagnetic environments. Otherwise, the battery control board may malfunction and cause a serious accident during use.
6. Never disassemble or pierce the product in any way. Otherwise, it may leak, catch on fire, or explode.
7. DO NOT use the product if it was involved in a crash or a heavy bump.
8. If the product falls into the water during use, take the product out immediately and put it in a safe and open area. Keep a safe distance from it until it is completely dry. Never use it again and dispose it properly as described in the Battery Disposal section below. If the product catches fire, it is recommended to use fire extinguishing equipment in the following order: water or water mist, sand, fire blanket, dry powder, carbon dioxide fire extinguisher.
9. DO NOT put the machine in a microwave oven or in a pressurized container.
10. Do NOT short-circuit the product with wires or other metal objects.
11. Avoid collision. DO NOT place heavy objects on the machine.
12. If the machine interface is dirty, wipe it off with a dry cloth. Otherwise, it will cause abrasion and result in energy loss or inability to charge.

Product Charging:

1. Always use NIUESS approved charging cables. NIUESS does not take any responsibility for any damages caused by using non-NIUESS charging cables.
2. When charging, please place the product on the ground with no flammable or combustible materials around. To prevent accidents, never leave the machine unattended during charging.
3. After continuous full-load discharge, if the product battery is in a high temperature state, it is recommended to wait for the device to cool to room temperature before charging, otherwise charging may be prohibited. The rechargeable ambient temperature of the battery is 0 °C - 45 °C, and the ideal charging ambient temperature (22 °C - 28 °C) can greatly extend the service life of the battery.

Product Storage and Transportation:

1. Keep the product out of the reach of children. If any children accidentally swallow parts, please see a doctor immediately.
2. If a low-battery warning appears after use, charge the product before storing it. Otherwise, long-term storage may cause damage to the batteries in the product. Batteries in the product will enter hibernation mode if they are depleted and stored for a long time. Recharging the product can bring the battery out of hibernation.
3. Do not place the machine near heat sources, such as a car in direct sunlight, a fire source, or a heating stove.
4. Store the product in dry environments. Please keep the machine away

from water or where it may leak.

5. Do not store or transport the machine together with glasses, watches, metal necklaces, hairpins or other metal objects.
6. Never ship a product with a battery power level higher than 30%.

Product Battery Disposal:

Be sure to completely discharge the battery of the machine before placing the battery of the machine in the designated battery recycling bin. Batteries are hazardous chemicals and should not be disposed of in ordinary trash cans. For details, please follow local laws and regulations on battery recycling and disposal.

Product Maintenance:

1. Do not store the battery of the machine for a long time in an environment where the room temperature exceeds 45°C or is lower than -20°C.
2. If the machine is idle for a long time, its performance will be affected.
3. Recharge and discharge every 3 months or so to keep the battery alive.

Travel Notice:

Lithium batteries and equipment with a capacity greater than 160Wh are prohibited. This product cannot be carried on board the aircraft.

CONGRATULATIONS!

Welcome to use the portable power station NE-1200. This short manual will help you. Please take a moment to read the manual and use the NE-1200 as instructed in the manual. You can fully grasp how to use the NE-1200 in just one reading!

Notice!

To turn the NE-1200 on or off, you need to press and hold the ON/OFF power key.

To turn on the AC power outlet, you need to PRESS and HOLD the AC Button after turning on NE-1200. We set the AC power button for users to turn off AC power when they don't need it and save power.

Please follow this introduction step-by-step to be familiar with each of NE-1200's ports, buttons, display screens and more. Please fully charge (100%) the NE-1200 before use it.

CONTENTS

Description of NE-1200	11
Introduction to Screen Interactive Display	17
Description of Alarm Prompt Information	20
Technical Specifications	23
Introduction of Special Functions	24
FAQs	27
Parts Box	32

Machine Description of NE-1200

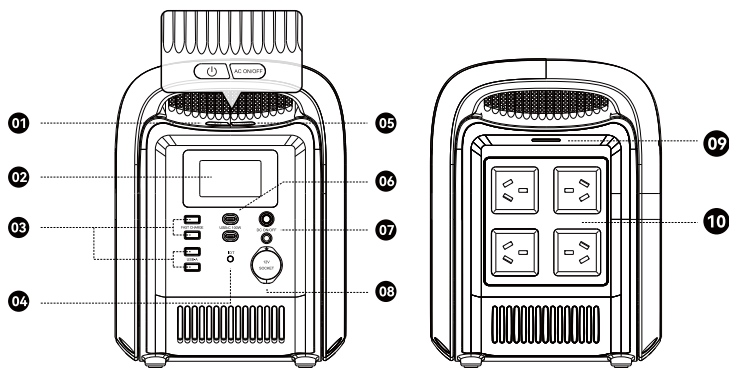

01 Main power switch/LCD switch/power indicator

Short press to start, short press the switch LCD screen to start, long press to shut down

02 LCD Display For details of the display, see the description of LCD display.

03 Fast Charge USB-A **04 LOT restart switch**

05 AC output switch, click it to turn on or turn off

06 USB-C 100W output

07 DC output switch & DC indicator light click it to turn on or turn off

08 DC output port

1 cigar lighter output, 2 DC 5521 output, output current 10A(Max)

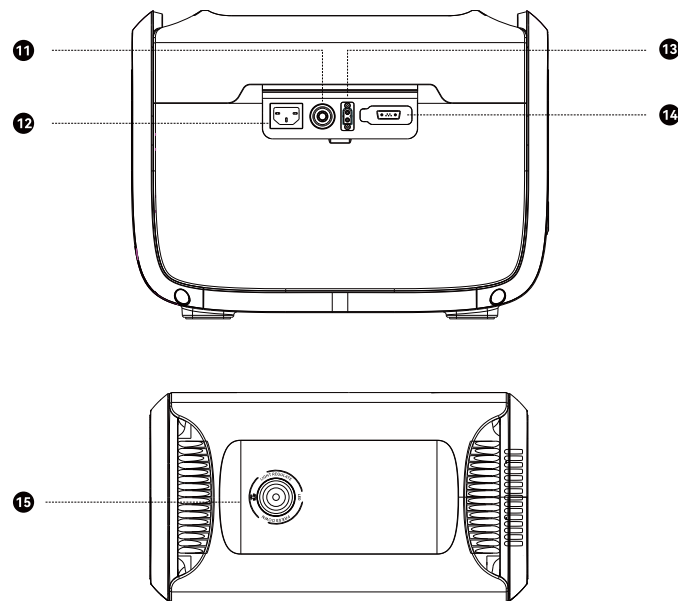

09 AC output indicator light **10 AC outlets**

11 AC charging input

12 Charging overload protect switch

13 Solar/DC/Cigar lighter input

14 Extended power pack connector

15 LED light with switch

short press to turn on shimmer lighting-stronger lighting-SOS flash-Turn off, it could be set by APP to colorful lighting, and press to turn off within 3 seconds

Physical Function Description

01 Main power switch/LCD switch/power indicator

Click this button to turn on the NE-1200, the power indicator is in breathing state, and the display is on. Short press to turn the display on or off and keep the device running. When NE-1200 detects an input or output access device or other key operations, the display screen will automatically light up. Otherwise, the screen will turn off automatically after the idle time exceeds 3 minutes (the rest time can be set by APP), but the device is still running. After the idle time exceeds two hours, the NE-1200 will automatically shut down (the shutdown time can be set by APP).

02 LCD Display

Display the power capacity, operation status, fault alarm and other prompt information of NE-1200.

03 Fast Charge USB-A

When the external device uses USB-A port for charging, the USB-A output indicator icon on the display screen will automatically light up; Charge the device that supports fast charging at a maximum speed of 24W. If your device does not support fast charging, the device will charge at a normal speed.

05 AC output switch

Click this button to turn on/off the AC output of NE-1200. Please close when the device is not in use.AC output, and be sure to unplug the power cord from the AC output port. No output detected for more than 10 hours,the NE-1200 will automatically turn off the AC output for you when the load is discharged.

06 USB-C 100W output

USB-C can charge devices including MacBookPro, Android phones and any other USB-C port devices. When the USB-C port is in use, the USB-C output indicator will automatically light up.

07 DC output & DC indicator light

Click to open or close DC output,This key controls the DC power output of NE-1200's Cigar lighter output port and DC 5521 output port. The indicator lights up when it is turned on, and turns off when it is turned off.

08 DC output port

The cigar lighter charger output port and DC5521 output port are connected in parallel internally, with the same voltage, and support the maximum 10A current output. It can be used for power supply of vehicle electrical appliances, or for charging of vehicle 12V battery (it must be used under the guidance of professionals).

09 AC output indicator light

The AC indicator lights up when the AC output switch is turned on, and turns off when the AC output switch is turned off.

10 AC outlets

Charge devices with voltage requirements of 120Vac/60Hz, such as laptops, TVs, mini refrigerators, vacuum cleaners, etc. With X-Turbo function, it supports the use of additional 1200W-2400W electrical appliances for power reduction (it does not support all excess electrical appliances, so you need to test to confirm that they can be used, so as not to affect your work and life).

11 AC charging input

Connect the AC cable of the universal zigzag port (cable capable of withstanding 15A effective current), and connect the other end to the AC power supply, supporting 120Vac/60Hz AC charging.

The X-Turbo system of the NE-1200 has the entry-level UPS function, which means that you can always connect to the AC power supply on the wall and use the NE-1200 AC outlets to working for devices at the same time (at this time, the AC power is from the grid, not from the battery). When the grid is suddenly powered off for <math>< 15\text{ms}</math>, it can automatically switch to the NE-1200 battery power supply mode to continue to escort your devices.

(Note: The UPS function of the X-Turbo system is an entry-level UPS function, not a professional UPS function, and does not support 0ms switching. Please do not connect it to the equipment with high requirements for uninterrupted power supply, or confirm whether it is compatible for reuse after multiple tests, such as data servers and workstations.)

12 Charging overload protect switch

When the input current is continuously greater than 15A during charging, the AC charging port will be protected (shown by the button popping up). After confirming that there is no fault with the machine, press the protection switch to reset to resume charging.

13 Solar/DC/Cigar lighter input

At most 4 110W solar panels can be connected in parallel, and the maximum input voltage is 65V. It can also support 12V/24V maximum 10A on-board power input. The device itself will limit input up to 400W. (When using the Cigar lighter, be sure to start the car to prevent the car battery from lower power and failing to start)

14 Extended power pack connector

This product can be connected to two power packs at the same time to meet the demand for larger capacity.

Please note the following when using:

1. Before connecting this product to the power pack, please ensure that both the product and the power pack are in the off state.
2. After connecting the power pack, make sure that the icon of the power pack appears on the LCD of the product and the power pack before using the product.
3. Please do not directly connect or remove the power pack during charging and discharging. If you need to connect or remove the power pack midway, please shut down the machine before operating.
4. Do not touch the metal terminal at the connection port of the power supply package with your hands or other objects. If the metal terminal is attached with foreign matters, please gently wipe it with a dry cloth.

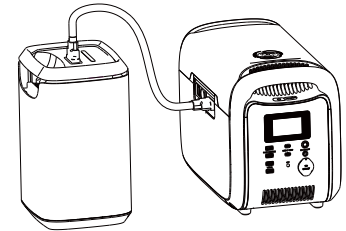

(Extended power pack connector)

15 LED light with switch

Press the LED transparent lampshade to switch the lighting effect. The light is divided into three levels: shimmer light, strong light, and SOS rescue signal flash. Short press to cycle to shimmer light/strong light/SOS flash/turn off LED. During this time, long press can turn off the LED directly.

Introduction to Screen Interactive Display

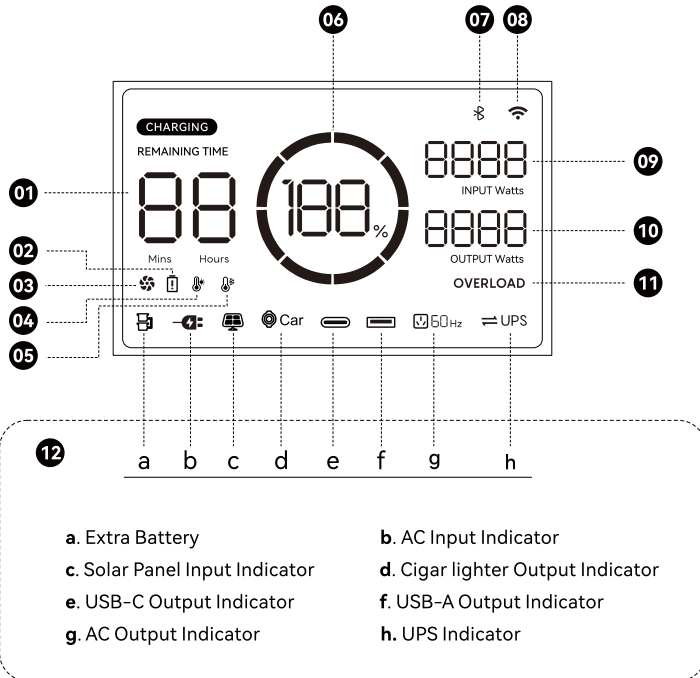

01 Remaining Charge/Discharge Time

Determine the remaining charge/discharge time based on the current power consumption of the device, accurate to minutes.

02 Error Indicator

This icon lights up when a fault occurs.

03 Fan Indicator

The working status and speed of the fan is controlled by the device, the icon flashes when it fails.

04 High Temperature Indicator

When the temperature of the equipment is too high, a high temperature warning icon will appear on the screen to warn the machine that the temperature is too high, please pay attention to cooling the machine.

05 Low Temperature Indicator

When the temperature of the device is too low, a low temperature warning icon will appear on the screen to warn the machine that the temperature is too low. Please warm up the machine properly before using it.

06 Battery Level Indicator

Displays the remaining power, and the power icon will cycle from left to right when charging.

07 Bluetooth indicator

Lights up when the bluetooth is connected normally, flashes when abnormal.

08 WiFi indicator

Lights up when WiFi is connected normally, and flashes when abnormal.

09 Input Power Indicator

Display the current input power of the device.

10 Output Power Indicator

Display the current output power of the device.

11 Overload Warning







Overload icons and corresponding parts indicate corresponding overload modules.







12 Port Status Indicator







Displays the usage status of each port. Lights up when the port is working normally and flashes when it is abnormal.

Description of Alarm Prompt Information

The equipment display screen uses different icons and combined icons to indicate the reason for device protection.

 OVERLOAD	USB-A Overload Protection	The USB-A and OVERLOAD icons flash together, and it can automatically resume operation after 10 seconds after unplugging the appliance.
 OVERLOAD	USB-C High Temperature Protection	USB-C and High-Temperature icons flash together. After the interface cools down, the interface will automatically resume operation.
 OVERLOAD	USB-C Overload Protection	The USB-C icon and the OVERLOAD icon flash together. After unplugging the appliance, it will automatically resume operation after 10 seconds.
 CHARGING	High Temperature Recharge- protection	The CHARGING icon, ERR icon, and high temperature icon flash together. This will happen especially when you charge your device immediately after a heavy battery use. Don't worry, please wait, it can be reused after cooling down.
 CHARGING	High Temperature Discharge- protection	The ERR icon and the high temperature icon flash together, please wait for the battery to cool down and then restore power.
 CHARGING	Low Temperature Recharging- protection	The CHARGING icon, ERR icon, and low temperature icon flash together, and the battery can be recharged by warming up the battery properly.

	Low Temperature Discharge-protection	The ERR icon, the low temperature icon flash together, please put it in a warm place and wait for the battery to heat up to restore power.
	Overload Recharging-protection	CHARGING icon, ERR icon and OVERLOAD icon flash together, unplug, restart the machine, then plug it back in, if the problem persists, please contact our product experts at support@repower.com
	Overload Discharging-protection	The ERR icon and the OVERLOAD icon flash together. Unplug the appliance and restart the machine to recover. The appliance must be used within the rated power.
	Communication Failure between Main Board and BMS	The ERR icon is flashing, if there is no recovery after restarting the machine, please contact our product experts at support@repower.com.
	Battery Failure	The ERR icon is always on, which means the battery is faulty, please contact our product experts at support@repower.com
	Communication Failure between Main Board and AC	The AC icon flashes, restart the machine and if there is no recovery, please contact our product experts at support@repower.com.

	Inverter Output Overload	The AC icon and the OVERLOAD icon flash together. After 10 seconds, restart the AC ON/OFF to restore. The electrical appliances must be used within the rated power (the power of electrical appliances in X-Turbo mode is limited, please refer to the introduction of X-Turbo functions).
	Inverter High Temperature Protection	AC and High-temperature icons flash together. Let the inverter cool down. Then turn AC Power On/OFF. It will automatically resume operation.
	Inverter Low Temperature Protection	The AC and Low-Temperature icons flash together. Move NE-1200 to a warmer place and wait for the inverter to warm up. Press AC Power ON/OFF button again. It will automatically recover.. If there is no recovery, please contact our product experts at support@repower.com.
	Fan Blockage	If the fan icon flashes, please check whether there is any foreign matter in the fan. If there is any foreign matter, please turn off the machine first and then remove the foreign matter. After completion, turn on the machine again to resume use. If there is no recovery, please contact our product experts at support@repower.com.
	Cigar lighter Output Overcurrent/Overload	The Car and OVERLOAD icons flash together, restart the machine to restore, and the electrical appliances must be used within the rated power.
	Cigar lighter High Temperature Protection	Car and High-Temperature icons flash together. Wait for NE-1200 to cool down and it will automatically recover.

Technical Specifications

General Specs	
Net Weight	18Kg
Size	403*223*298(mm)
Capacity	1228Wh(38400mAh)51.2V
Certification Standards	CE/FCC/GB/PSE/RoHS/UKCA /UL
APP	Support
Output	
AC Output (pure sine wave)	Rated power 1200W, peak value 2400W, 120Vac(60Hz) Intelligent inverter system: support 1200-2400W equipment
USB-A Charge (x2)	12W,5V DC 2.4A(max)
USB-A Fast Charge (x2)	24W,5V DC 3.4A,9V DC 2.5A,12V DC 2.4A(max)
USB-C Fast Charge (x2)	100W,5/9/12/15/20V DC,5A(max)
Cigar lighter Output	136W,13.6V DC,10A(max)
Dc5521 Output	13.6V DC,10A(max)
Input	
AC Charge Input Voltage	90~130Vac 60Hz
AC Charge Input Power	Maximum input power 1000W
Solar Charge Input	400W,11-65V DC,10A(max)
Cigar lighter Input	200W(max),12V/24V DC,10A(max)
Battery	
Cell Type	High-rate automotive-grade power cells
Discharge Temperature	-20°C-50°C±3°C
Charge Temperature	0°C-45°C±3°C
Cycle Life	2000 cycles(80%+)

Introduction of Special Functions

X-Turbo—AC Fast Charging Mode Introductor

X-Turbo allows you to use electrical appliances with a rated power of 1200-2400W without overload protection and power failure, and you do not need to worry too much about the power limitation of the energy storage power supply. With traditional inverters, as long as an electrical appliance exceeding the rated power is used, the equipment will be overloaded, thus making such electrical appliances unusable. Please note when using:

- 1、 The X-Turbo function is enabled by default in the factory equipment. If you want to disable this function, you need to operate it in the APP developed later; X-Turbo cannot be used when the AC output is connected to the home grid, otherwise the low-voltage protection will trip during use.
- 2、 The X-Turbo function cannot be used in the charging state and when the X-Turbo is not turned on, please pay special attention.
- 3、 When using an electrical appliance with a rated power of 1200-2400W, please connect only one appliance, so as not to affect the use effect of other electrical appliances due to voltage changes when multiple appliances are used.

* The X-Turbo function is not suitable for all appliances, and some have power ratings that have strict requirements on voltage. 1200-2400W electrical appliances are still incompetent, so please do a full test before traveling, so as not to affect your work. Air conditioners and air compressors are not recommended to avoid damage to electrical appliances. It is recommended to use heating electrical equipment with a rated power of 1200-2400W, such as hair dryers, electric kettles, coffee machines and other equipment.

X-Turbo—Introduction to Entry-level UPS Functions

Entry-level UPS Usage Reminder

The X-Turbo system has entry-level UPS function, which means that you can use the AC outlet of the device to work while connecting to the AC power supply on the wall (the AC power is from the grid, not the battery at this time). When the grid suddenly loses power, it can automatically switch within <15ms Battery powered mode for device.

However, this function is a non-professional UPS function and does not support 0ms switching. Please do not connect it to equipment that requires high requirements for uninterrupted power supply, or please test it several times to confirm whether it is compatible before using it. The company is not responsible for equipment that does not operate normally, or data loss, such as data servers and workstations, otherwise it will affect your experience of using the machine.

Entry-Level UPS User Guide

Users can connect the AC charging cable connected to the device to the power grid, then connect the electrical appliance to the AC output port of the device, and turn on the AC switch to automatically switch to entry-level UPS mode. When the power grid is cut off, the device can continue to use the battery energy to supply power to the electrical appliances, escorting your device (as shown in the figure below).

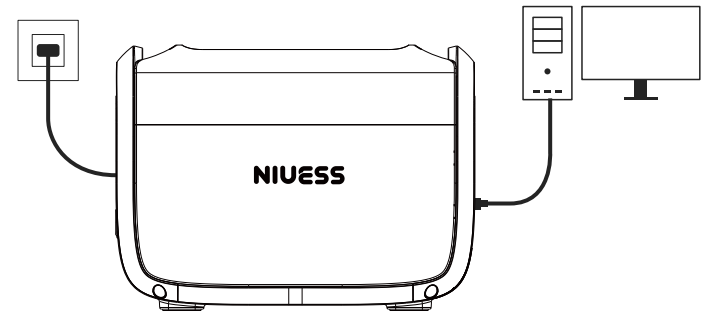

*UPS only supports the use of electrical appliances below 1200W, and do not use other equipment at the same time to avoid OVERLOAD during use. Our company is not responsible for abnormal operation or data loss caused by careless use. Only one device can meet the UPS function according to the following diagram, and the UPS function is not available when multiple devices are connected.

FAQs

Solar Panel Connection Diagram

How to recharge the device using solar panels?

To connect a single solar panel, see the solar panel instructions. Here we focus on the connection method of 1 or 4 solar panels. The device can accept 11-65V DC input, when the input exceeds 65V, the device will trigger overvoltage protection. Excessive voltage may damage the product. Users should follow these instructions. If the specified number of connections is exceeded or the connections are not made in accordance with the specifications, the company will not be responsible for the free maintenance service of the damaged machine within the warranty period.

1.Connection/Parallel Charging Method (Recommended Scheme)

You can connect one solar panel (does not support multiple series in series) through the MC4 interface according to the method of Case 1, then connect our MC4 to XT60 cable, and use the XT60 connector to connect to the XT60 interface on the device to charge.

In addition, you can connect up to 2 sets of solar panels in parallel according to case 2 through the MC4 interface. When you want to connect 2 solar panels, you can connect the two sets of solar panels in parallel, and then connect our MC4 to XT60 connection. Connect the cable to the XT60 port on the device with the XT60 connector to charge. Parallel connection is not standard and needs to be purchased separately by the user.

e.g.1

NE-1200 charging interface area

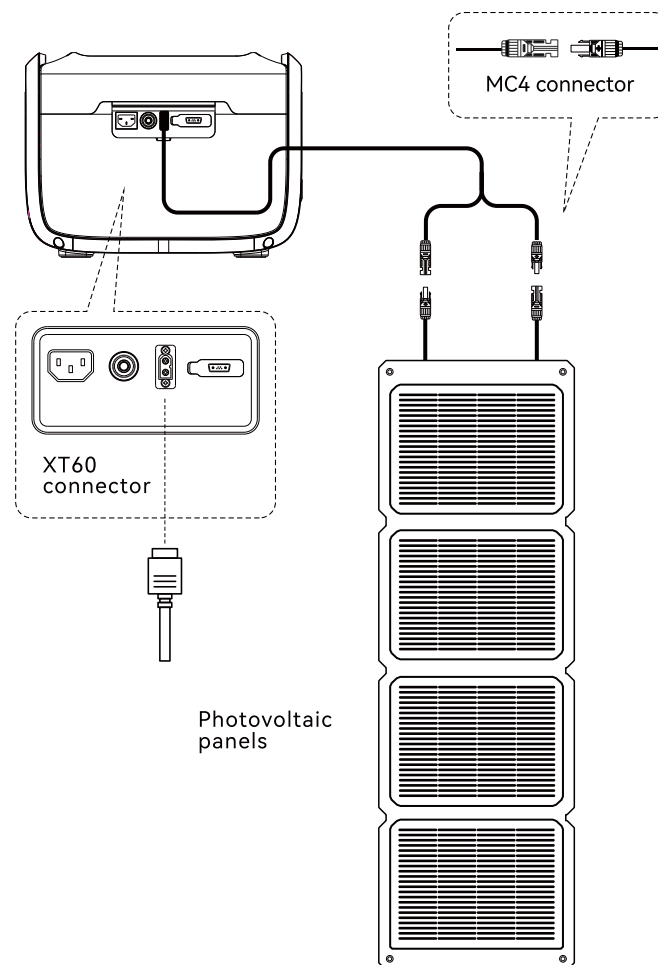

e.g.2

NE-1200 charging

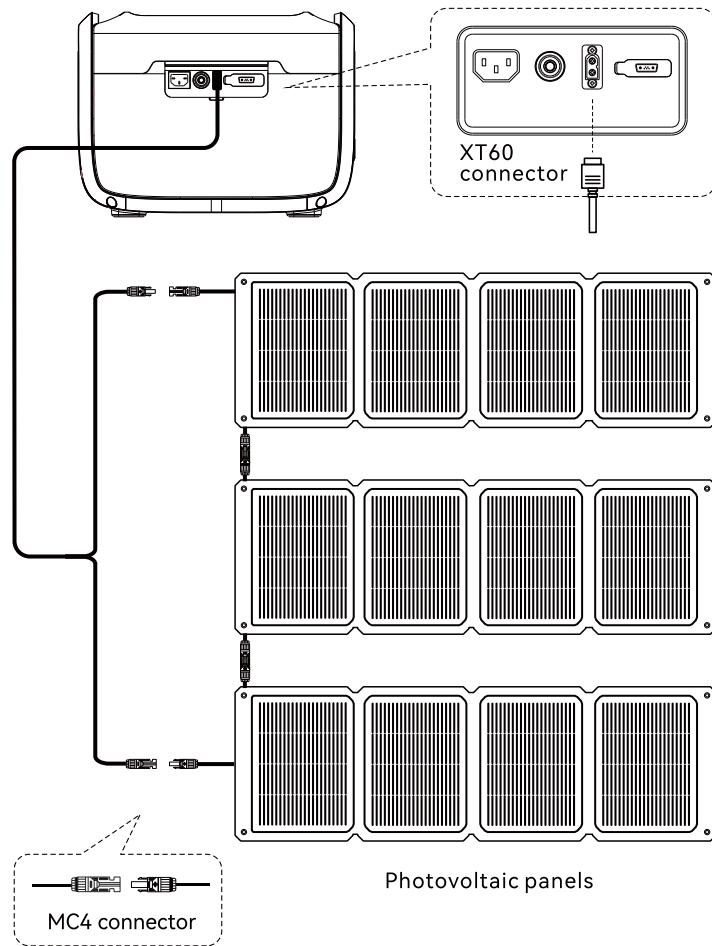

2.The device supports the use of third party solar panels (DIY solution)

Users can use the universal solar panel with MC4 interface standard purchased from their own channels to power the device. As long as the voltage and current (11-65V 10A Max) meet the requirements of the device, the device can be powered through the MC4 to XT60 adapter cable. Please pay attention to the following picture. The order in which the positive and negative poles are connected, the wrong connection will cause the risk of damage to the device. During the warranty period, the machine is damaged due to equipment failure caused by third-party solar panel quality problems or improper operation. The company does not undertake free maintenance during the warranty period.

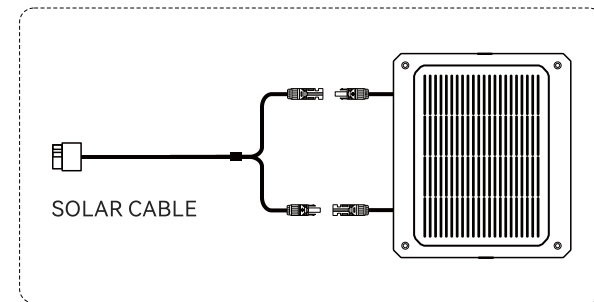

How to charge NE-1200?

The AC charging port that comes with the NE-1200 fuselage—the 3 pins plug, and the DC charging port—the XT60 port, are located on the side of the fuselage. You can charge the device from AC power, vehicle 12V/24V DC power and solar panel with XT60 cable.

Note: When the XT60 and AC port are connected to the input at the same time, only the AC input is enabled.

How to maintain the NE-1200?

NE-1200 is versatile, so it is likely that a simple cleaning will be required from time to time. Wipe with a dry, non-abrasive cloth. If you also want to wipe even more cleanly, we recommend using a cleaner designed for mobile phone and computer screens. Do not expose the product to large amounts of water!

How to store the NE-1200?

Store NE-1200 in a dry place and avoid direct contact with water. In order to prolong the battery life, if you need to store it for a long time, please charge it to 30%-80%, turn off the main switch and store it at room temperature.

How to use the NE-1200 safely?

Please use the NE-1200 under temperature conditions within its operating temperature range. Use of the NE-1200 outside of its optimum temperature operating range may cause the NE-1200 to exceed its safe and effective operating limits. Do not immerse the NE-1200 in water. The NE-1200 is not waterproof and doing so will void your warranty. It is normal for over-temperature protection to appear when using a 1200W heating appliance for more than half an hour. Please wait for about 1 hour before using or charging.

Is it possible to upgrade?

The NE-1200 can upgrade the firmware version through the subsequently developed APP to optimize the operation of the device, and the corresponding parameters of the machine will also be adjusted and optimized. Please refer to the release notes for firmware upgrade.

What's in the parts Box?

NE-1200 Main Unit
AC Charging Cable(Input)
Cigar lighter Cable(Input)
Solar Charge Cable(MC4 to XT60 Input)
DC 5521-5525 Cable
User Manual/Simple Operation Guide/Warranty
Card/Qualification Certificate/Packing Box