



www.stksupply.com
 (+57) 320 766 9986

USER WARNING

WARNING

MANUFACTURER'S INSTRUCTIONS
 MUST BE READ AND UNDERSTOOD
 PRIOR TO USE.

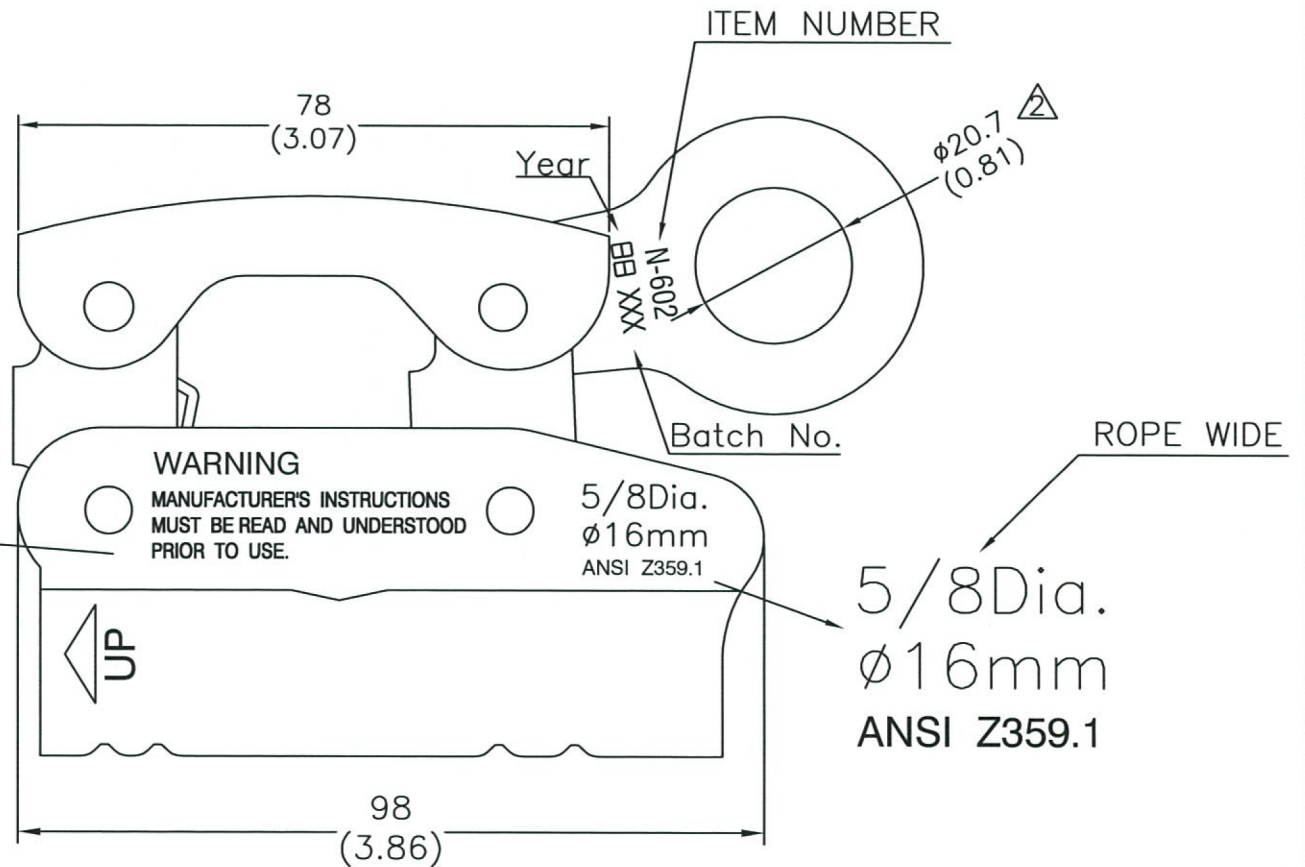

N.W. 0.458 Kg
 (DIMENSION IN $\frac{MM}{INCH}$)

△	Modify the dimensions	13.02.21	Wei
SYM.	REVISION DESCRIPTION	DATE	REVISION BY

YOKE [®] INDUSTRIAL CORP. #39, 33rd Road, Taichung Industrial Park, Taichung 407, Taiwan, R.O.C. Tel: +886-4-350-8088 Fax: +886-4-350-1001	DRAWING NAME	ROPE GRAB WITH EYE						
	MATERIAL	STEEL	DRAWING BY	Wei	DRAWING DATE	2012/05/23	EDITION	2
	FINISH	PLATED	CHECKED BY		APPROVED BY	陳學維	REVISION DATE	
	MINI. BREAK	3600LBS/16kN	SCALE	1:1	DRAWING NUMBER	N-602		