

## Istruzioni per l'installazione della Maniglia a Molla

### Contenuti

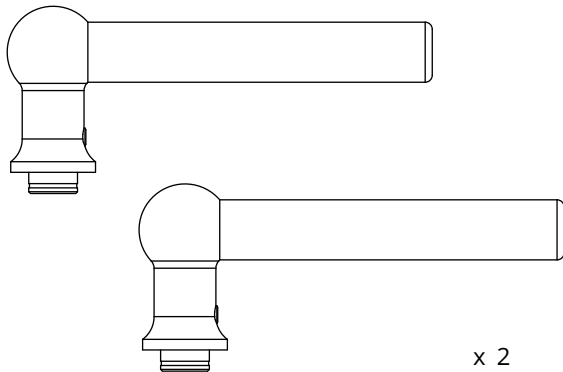

Maniglie

x 2

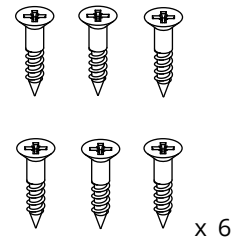

Viti per legno

x 6

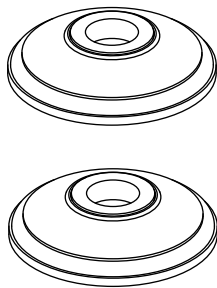

Rosette

x 2

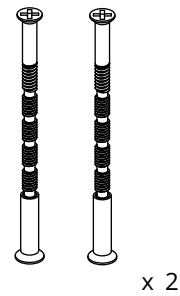

Bulloni passanti M4

x 2

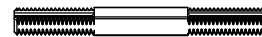

Mandrino filettato

x 1

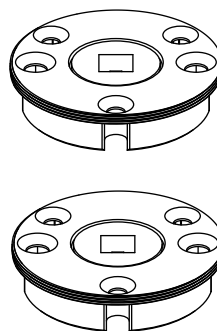

Meccanismo a molla

x 2



Blocca filetto

Meccanismo a molla

x 1

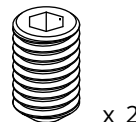

Vite di fermo

x 2



Vite di fermo con blocca filetto pre-applicato

x 2

## Installazione su Porta Nuova

Durante l'installazione delle maniglie su una porta nuova, suggeriamo di forare prima la sede per il chiavistello e poi tutti i fori per la maniglia

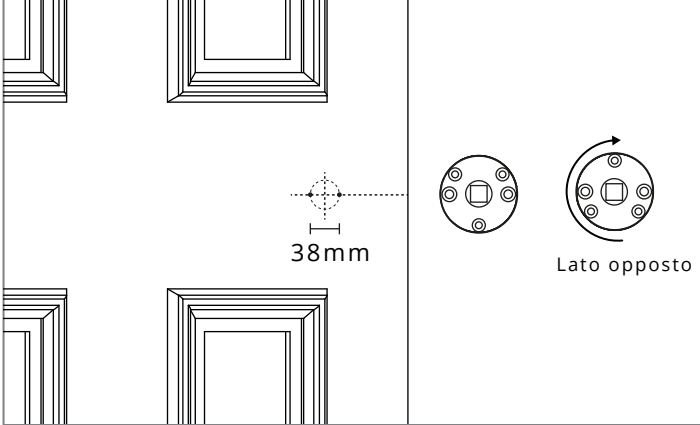
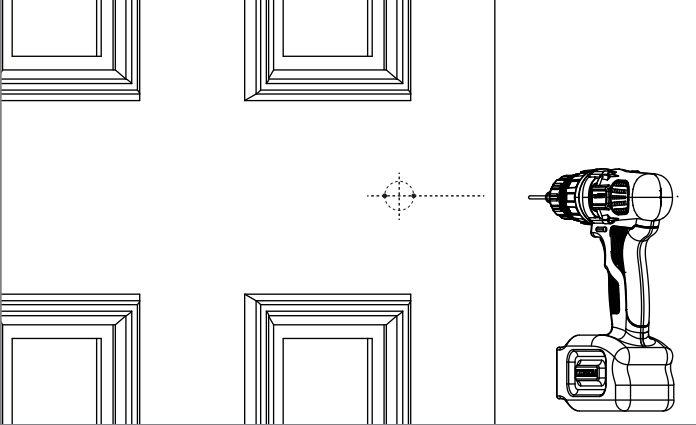
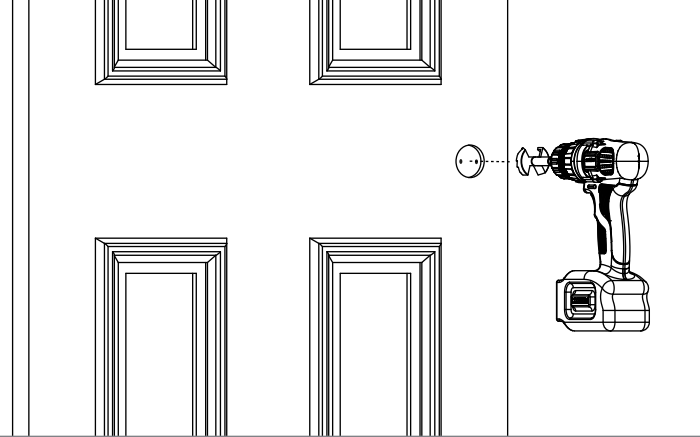
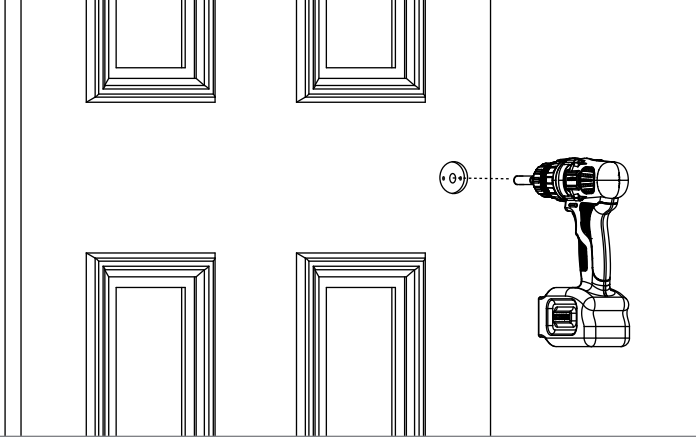
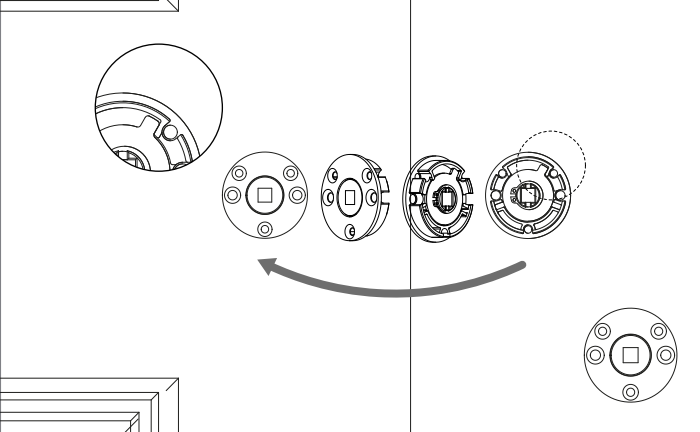
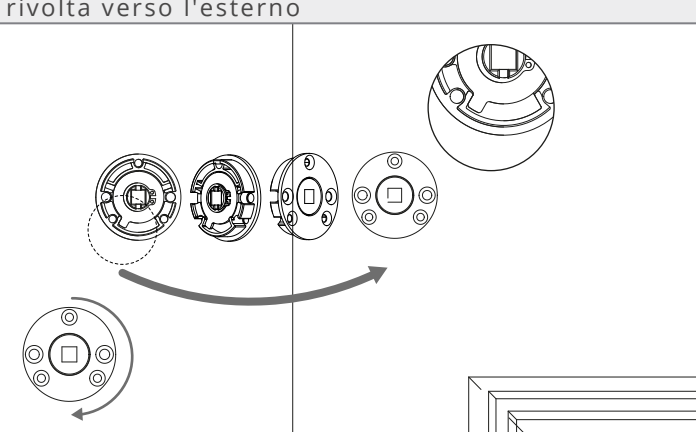
<p>1a Segna le linee centrali su entrambi i lati della porta</p>	<p>2a Fai dei fori nella porta per i bulloni passanti usando la punta da 8mm</p>
	
<p>3a Fai un foro da 45mm, profondo 10mm, usando la punta Forstner Corston su ogni lato</p>	<p>4a Usando la punta da 12mm, fora al centro del foro per il mandrino</p>
	
<p>5a Inserisci il meccanismo con la tacca del limitatore rivolta verso l'esterno della porta</p>	<p>6a Inserisci il secondo a 180° rispetto al precedente assicurandoti che la tacca sia rivolta verso l'esterno</p>
	

Forare un nuovo buco nella porta può essere difficile con un buco già esistente. Usare la dima per foratura rende molto più semplice creare un nuovo buco preciso.

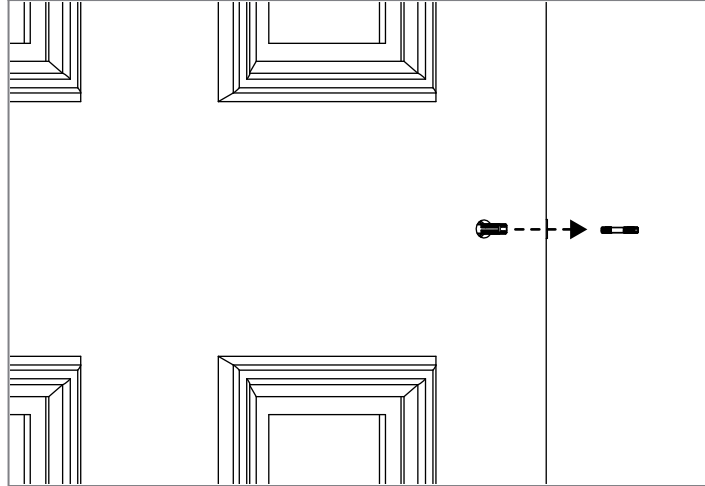
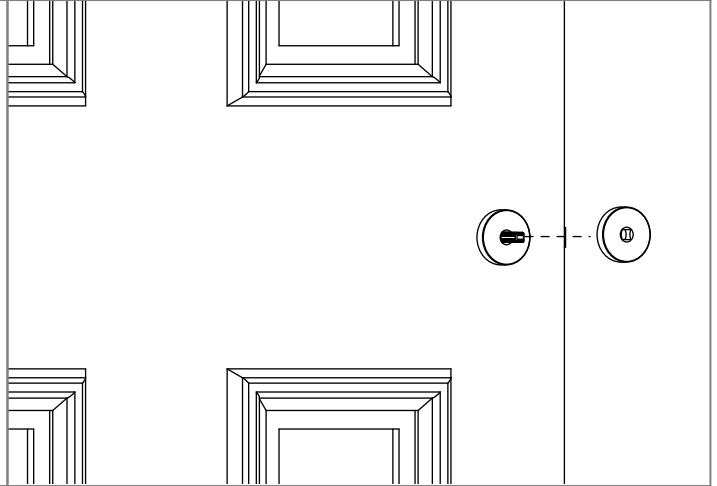
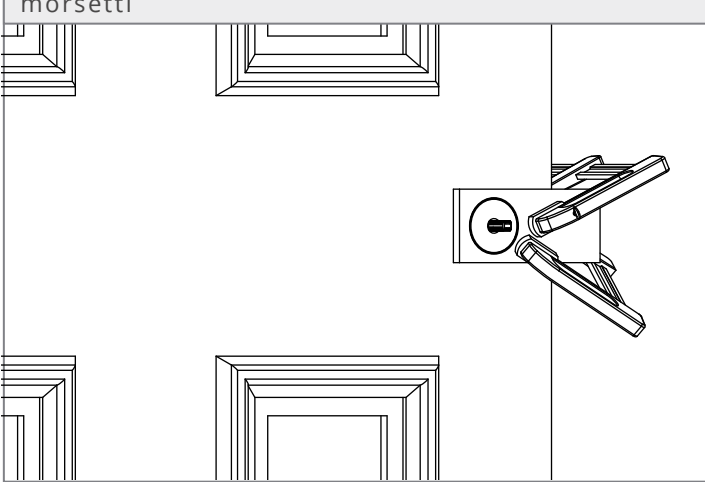
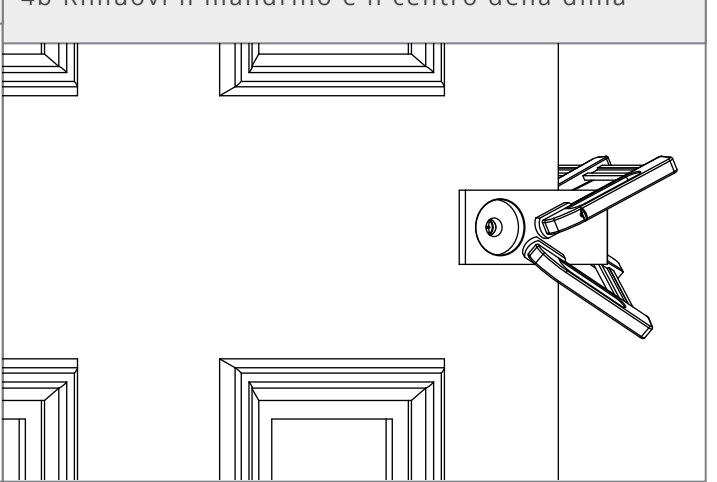
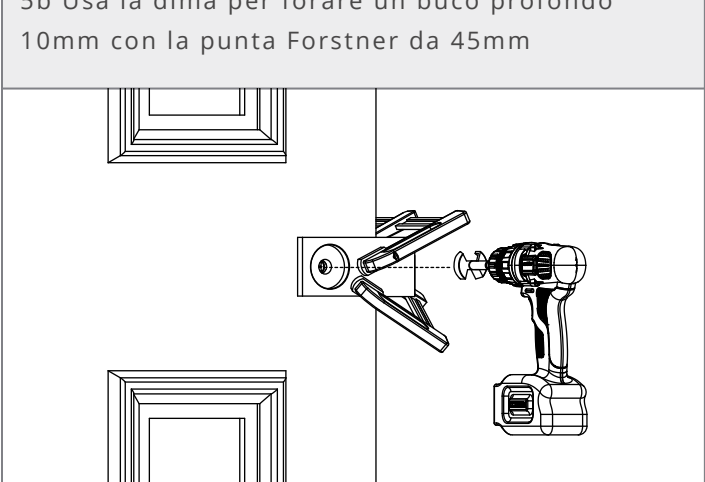
<p>1a Inserisci il mandrino nel chiavistello</p> 	<p>2b Posiziona la dima centrata sul (18685)</p> 
<p>3b Fissa saldamente la dima alla porta con i morsetti</p> 	<p>4b Rimuovi il mandrino e il centro della dima</p> 
<p>5b Usa la dima per forare un buco profondo 10mm con la punta Forstner da 45mm</p> 	<p>Prosegui dal passaggio 5a</p>

**Procedura di Installazione**

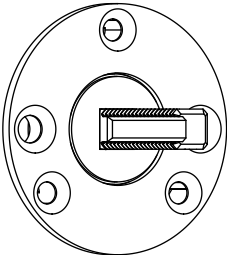
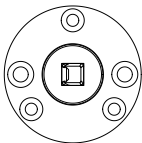
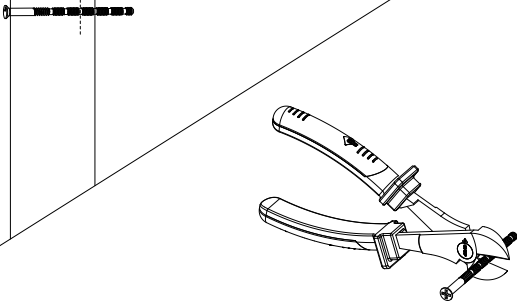
<p>7a Controlla che il mandrino passi, se non si adatta, allarga i fori da 45mm</p>		<p>8a Taglia le viti snap off alla misura affinché siano più corte della profondità della porta</p>	
	 <p>Orientamento corretto</p>		

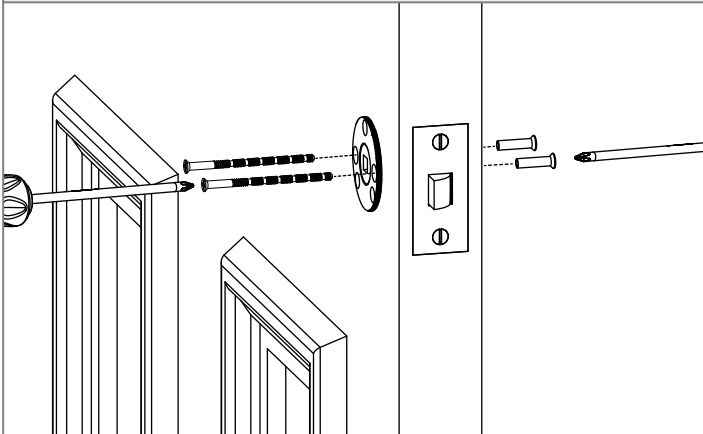
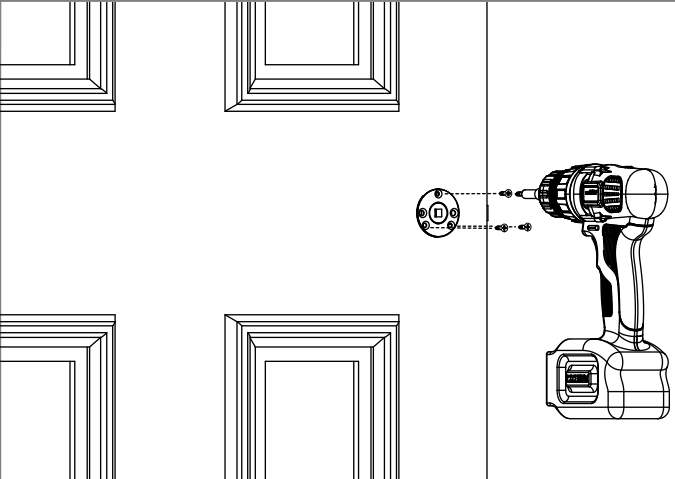
<p>9a Inserisci i bulloni passanti, usare due cacciaviti può essere utile</p>		<p>10a Avvita le viti per legno</p>	
			

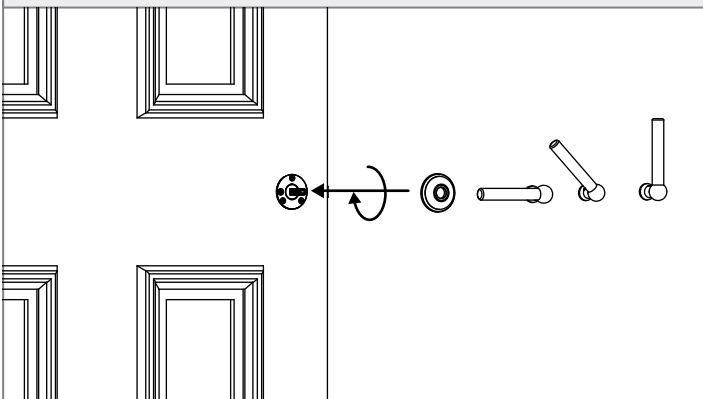
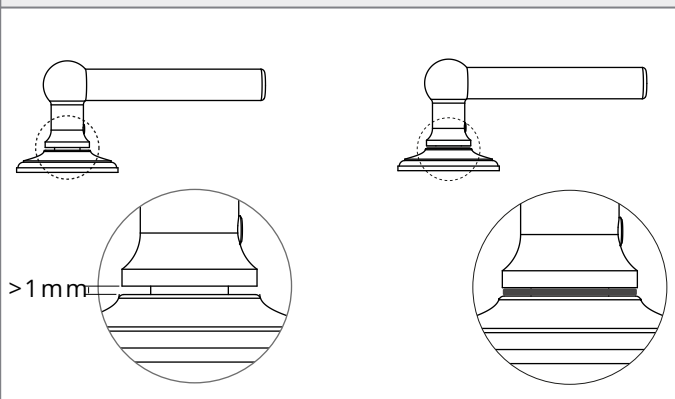
<p>11a Avvita rosette e maniglie sul mandrino, lasciando un piccolo spazio tra la rosetta e la maniglia</p>		<p>12a Se, dopo aver avvitato la maniglia, c'è uno spazio maggiore di 1mm tra la maniglia e la rosetta, usa una rondella per riempire lo spazio</p>	
			

Procedura di Installazione

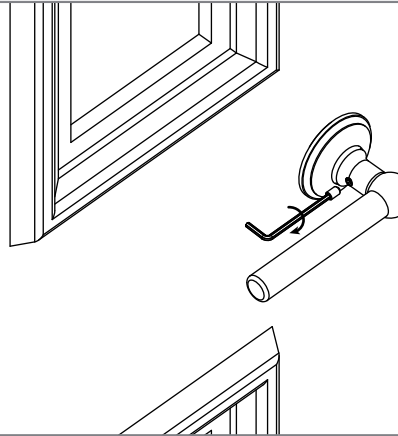
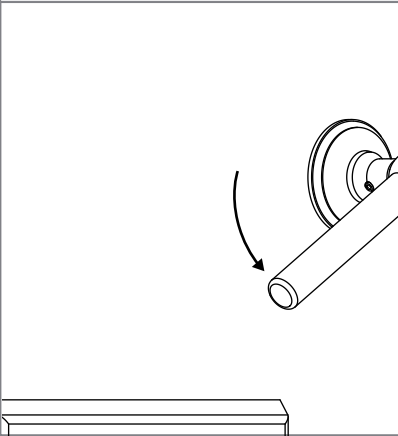
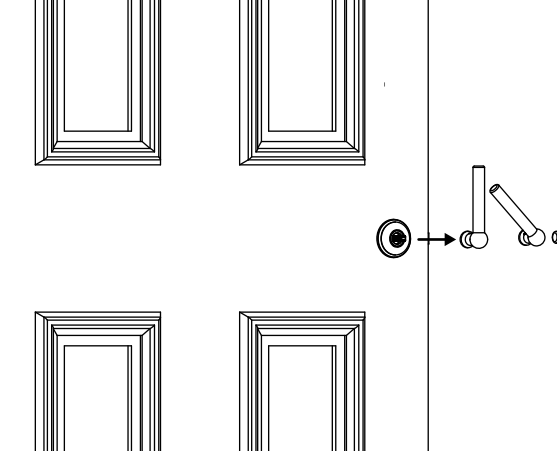
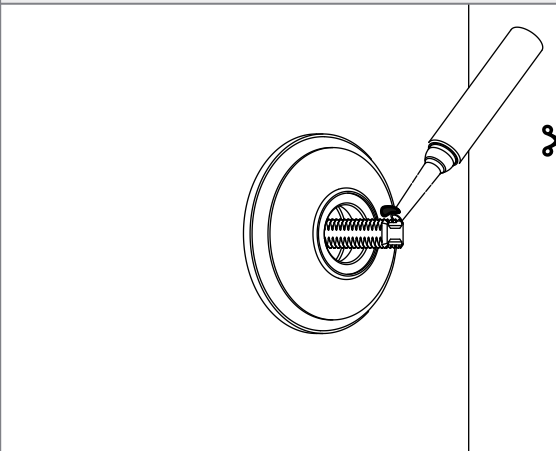
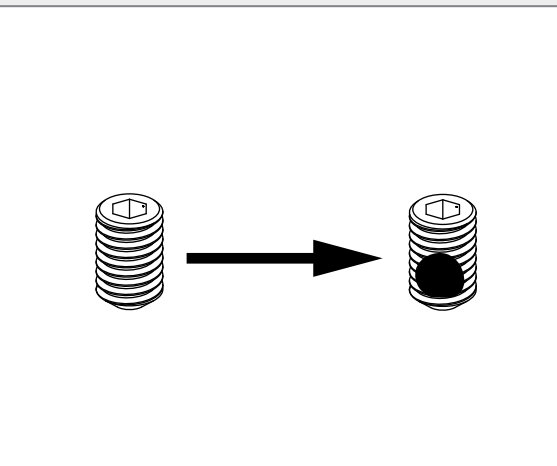
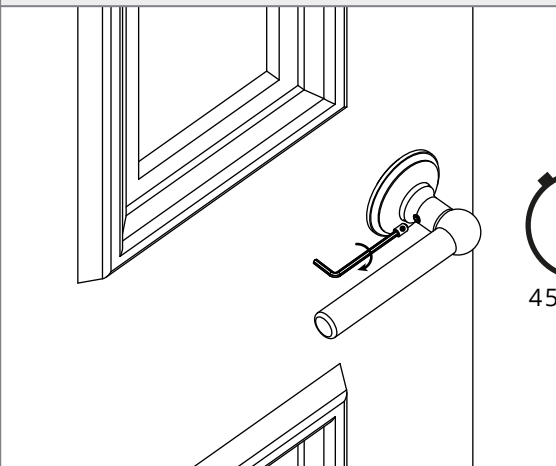
<p>13a Avvita le viti di fermo, assicurandoti che la maniglia sia livellata</p>	<p>14a Controlla che la maniglia giri con fluidità</p>
	
<p>15a Rimuovi le maniglie</p>	<p>16a Applica il blocca filetto sul mandrino e reinstalla la maniglia</p>
	
<p>17a Applica il blocca filetto sulle viti di fermo</p>	<p>18a Reinstalla e attendi che il blocca filetto si solidifichi</p>
	 <p>45 mins</p>

## Istruzioni per l'installazione della Maniglia a Molla

### Strumenti necessari

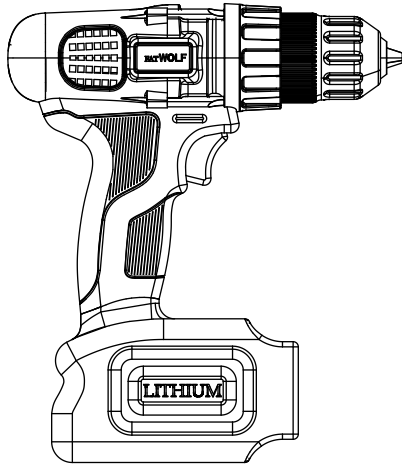

Trapano

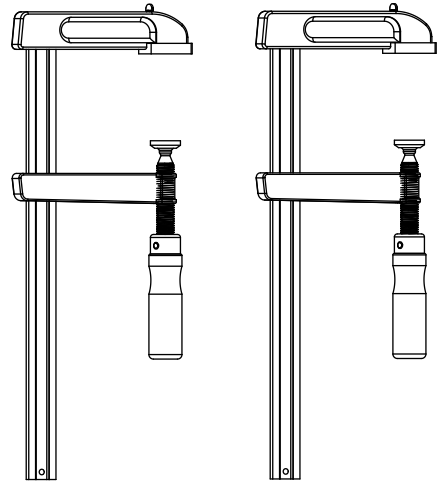

Morsetti

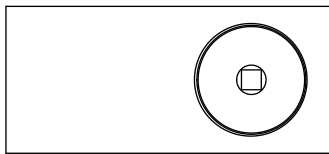

Kit di montaggio Reto (18685)

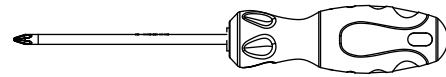

Cacciavite PZ2

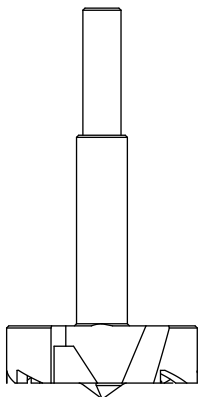

Punta Forstner da 45mm (14495)



Punta da trapano da 12mm



Punta da trapano da 8mm

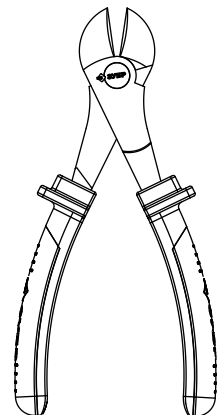

Pinze