



ZULU

Back in Black

AH-1Z - 168961

HMLA-267

MCAS Futenma - 6/16/19

TPS scheme FS 35237 over FS 36375. Use Kit stencils.

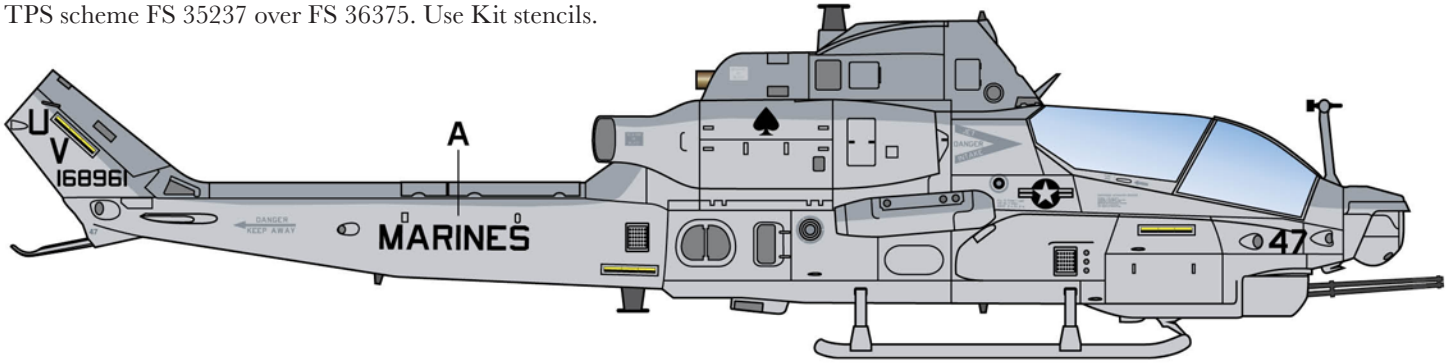

AH-1Z - 169512

HMLA-775

MCAS Camp Pendleton - 3/8/23

TPS scheme FS 35237 over FS 36375. Use Kit Stencils.

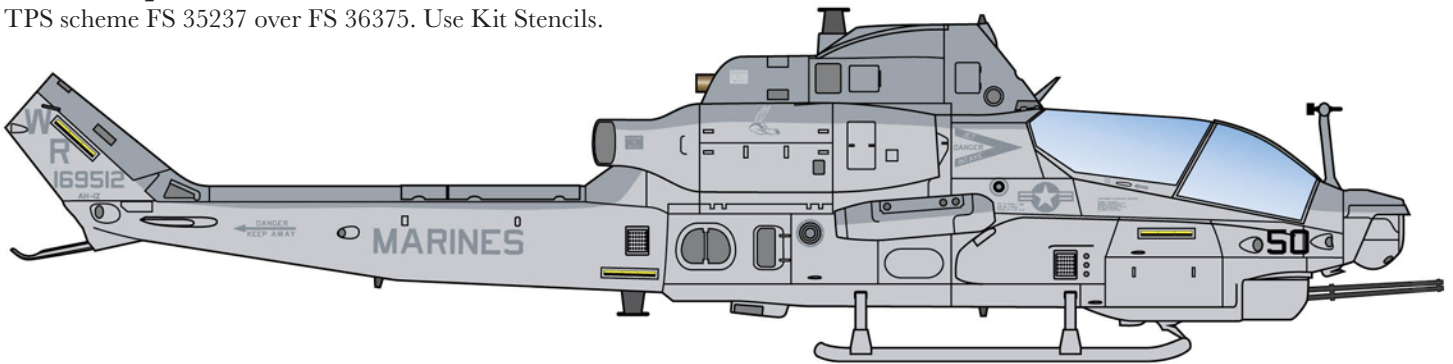

AH-1Z - 169258

VMM-362 (REIN)

MCAS Miramar - 9/23/23

TPS scheme FS 35237 over FS 36375. Use Kit Stencils. This aircraft has the DI-FMV antennas on the tail boom.

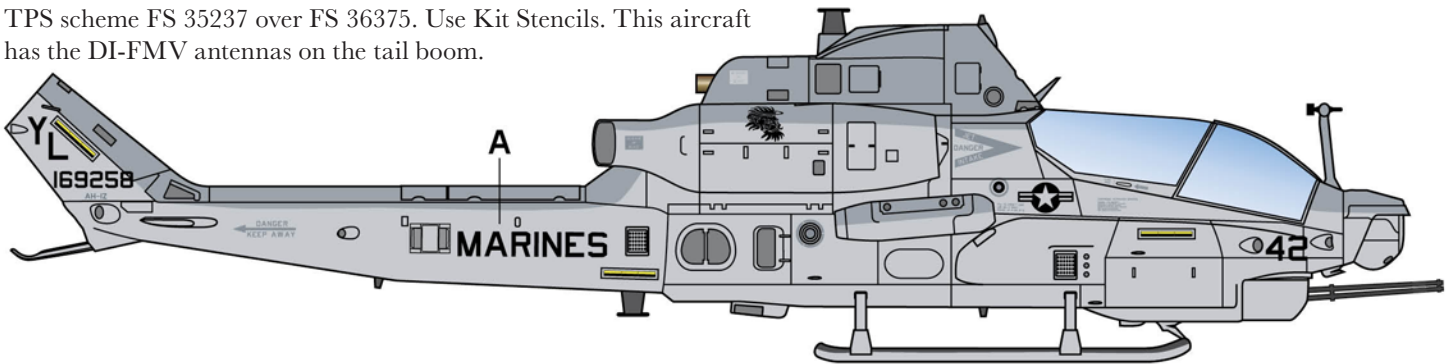

AH-1Z - 169251

VMM-164 (REIN)

15th MEU - 12/11/20

TPS scheme FS 35237 over FS 36375. Use Kit Stencils. This aircraft has the DI-FMV antennas on the tail boom.

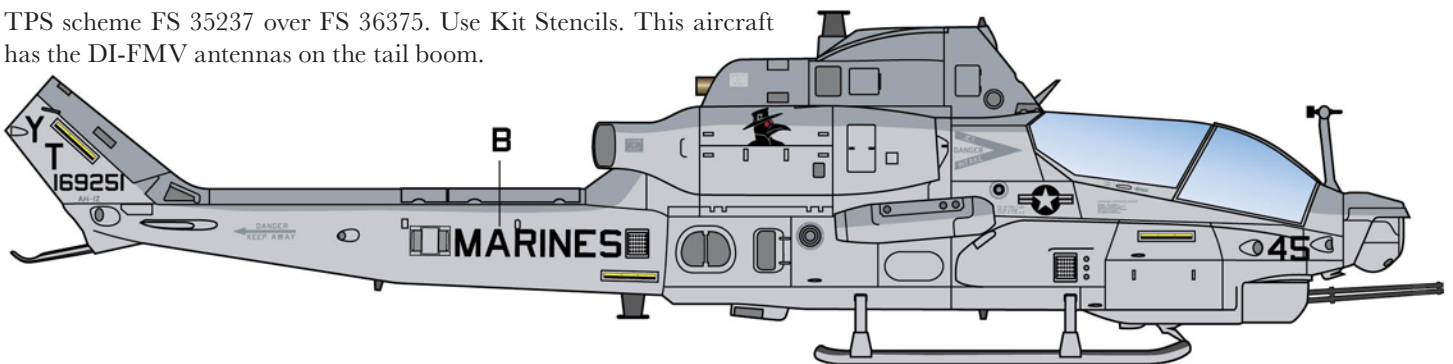

AH-1Z - 169498

HMLA-169

MCAS Camp Pendleton - 3/28/23

TPS scheme FS 35237 over FS 36375 overpainted with Medium Green FS 34095 and Black FS 37038. This aircraft was first painted in this scheme by HMLA-269 and then transferred to -169, it has been touched up several times.

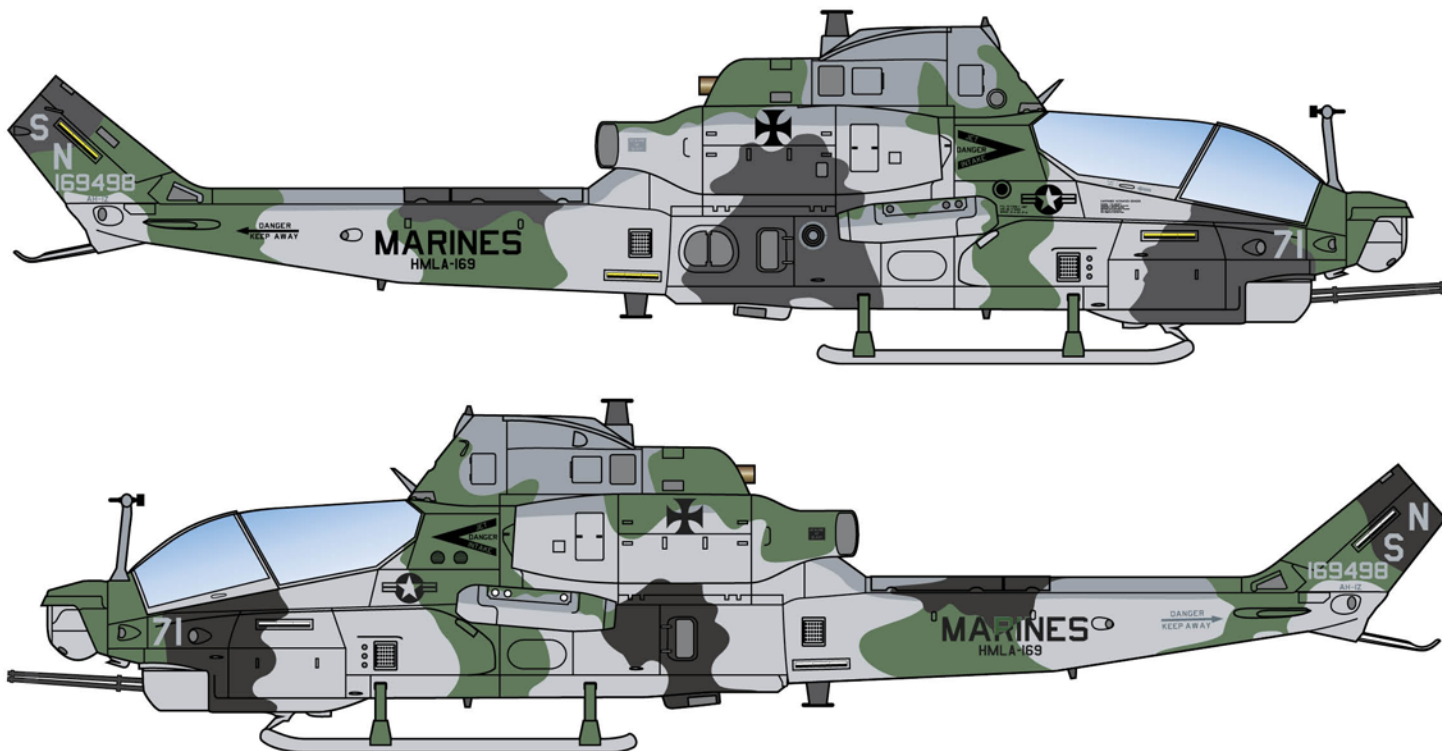

AH-1Z - 786-072

Pakistan Army

Amarillo, TX - 8/17/17

Overall FS 34088. Use black stencils on this sheet.

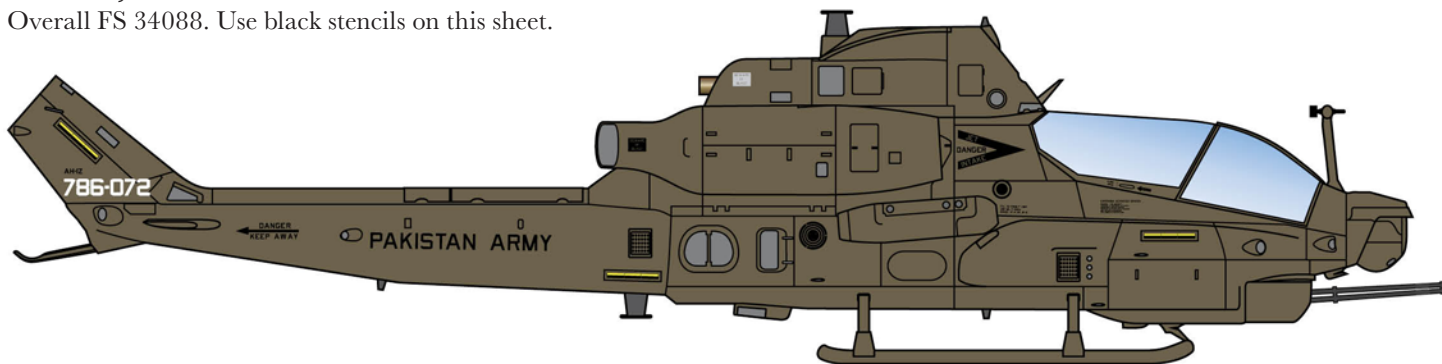

AH-1Z - 2201

Royal Bahraini Air Force

11/10/22

TPS scheme FS 35237 over FS 36375. Use Kit Stencils. This aircraft has the nose bay doors without rivets, see Czech version.

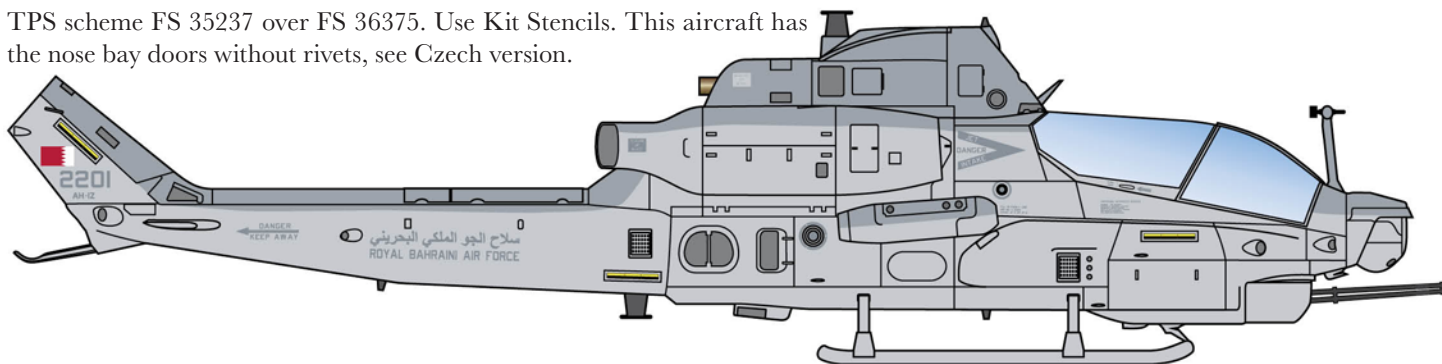

AH-1Z - 0486

Czech Air Force

Amarillo, TX - 3/28/23

Camouflage consists of Dark Olive Green FS 34096, Gunship Gray FS 36118 and Medium Sea Gray FS 36270 with Lt Ghost Gray FS 36375 on the bottom surfaces. Use the black stencils on this sheet. This aircraft has the nose bay doors without rivets, see photo.

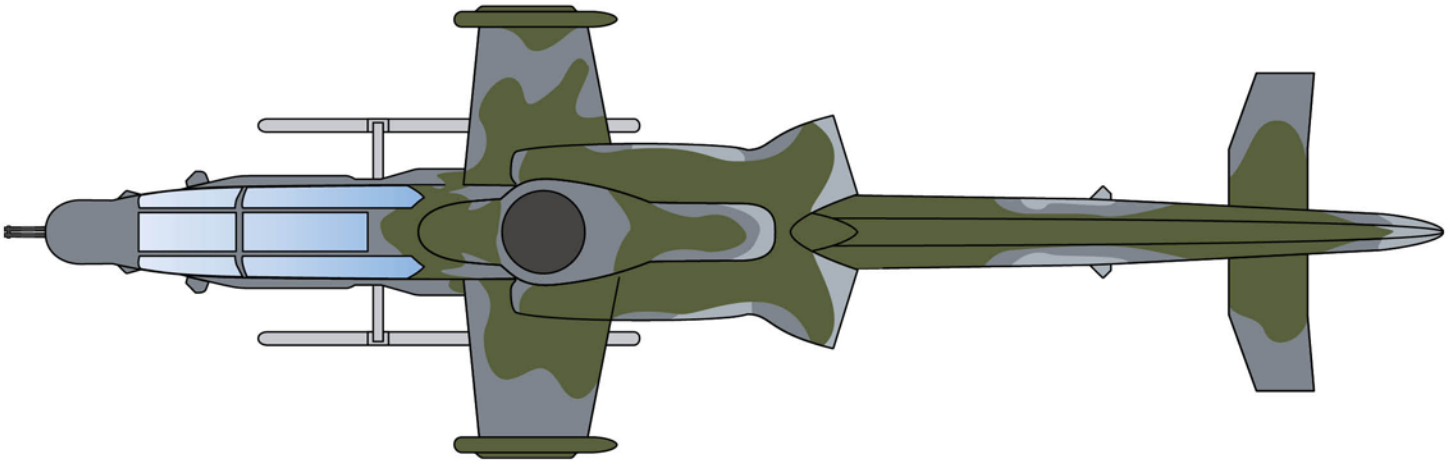
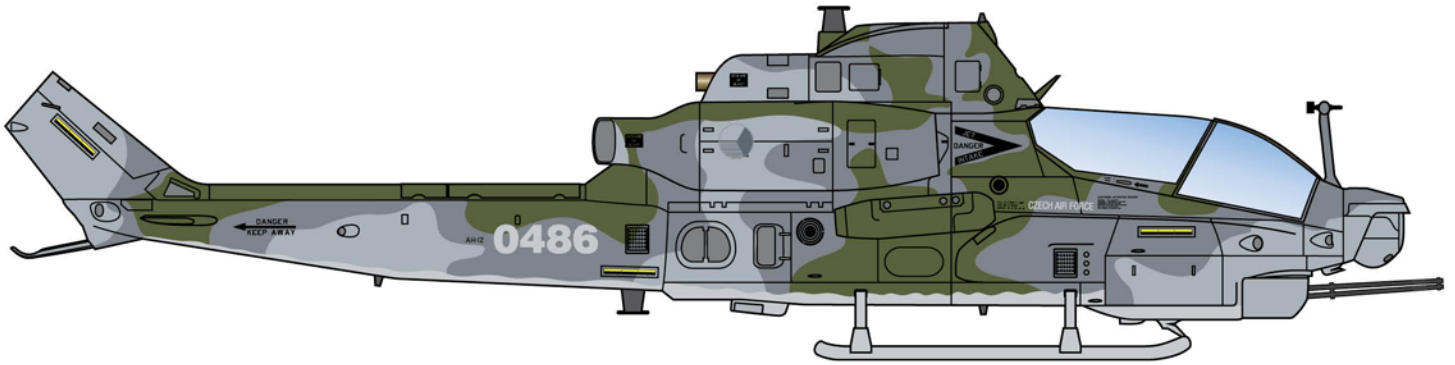

Nose

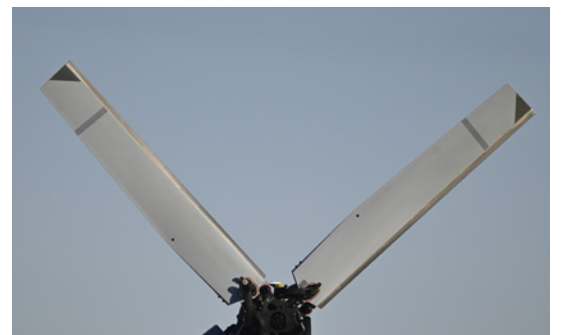

The AH-1Zs flown by the Royal Bahrainian Air Force and the Czech Air Force have doors that do not have the visible rivets found on most AH-1Zs.

AH-1Zs flown by the Pakistan Army, RBAF and the CZAF have markings on the tail rotor blades, they have also been seen on some Marine Zulus.

Stencil placement

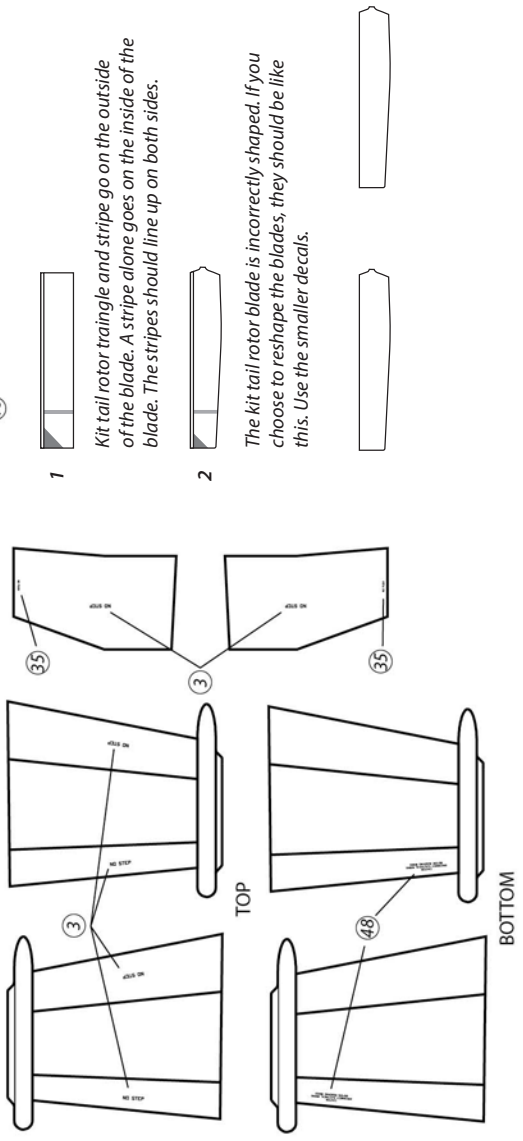
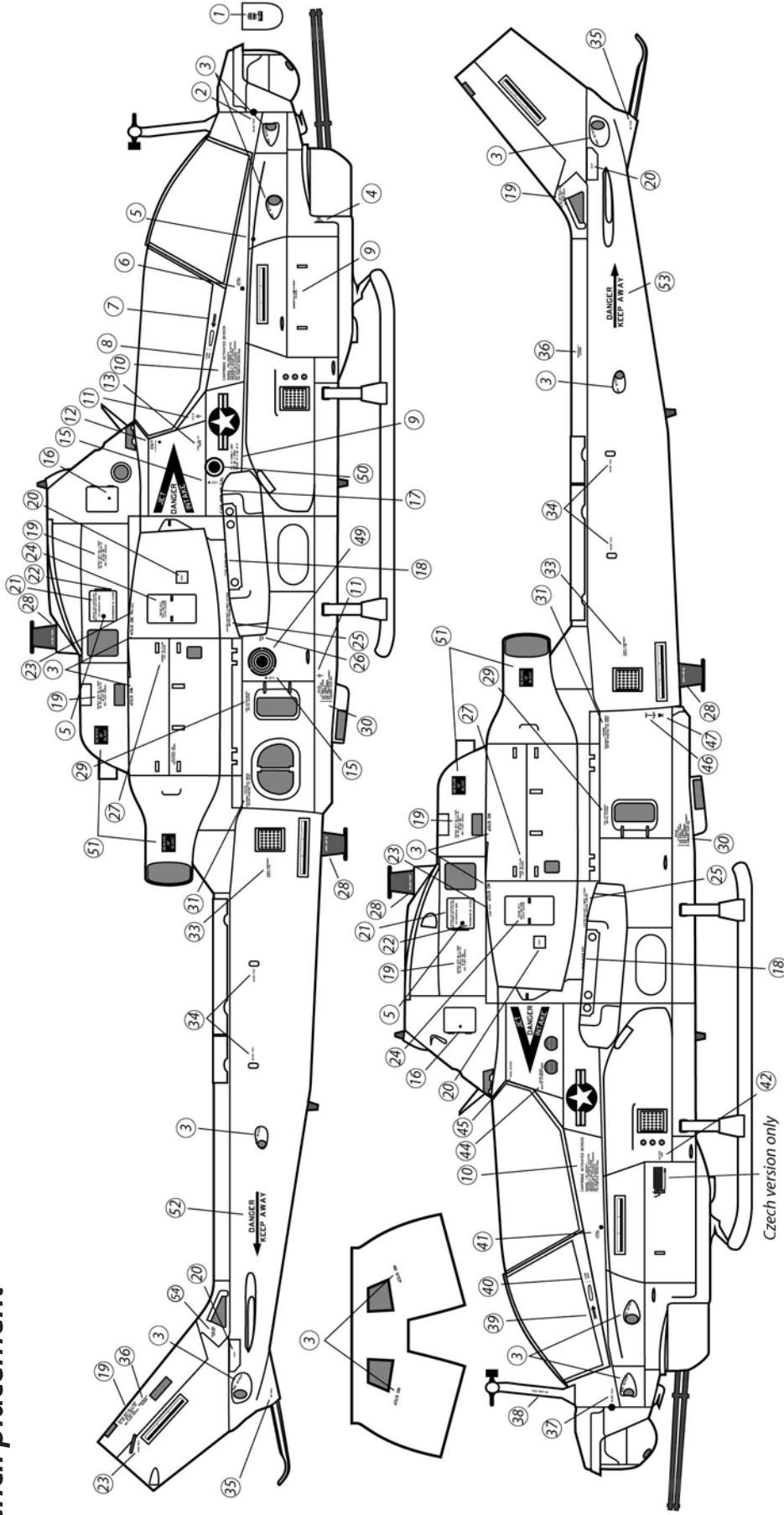

Notes:
 The main rotor blades are 36-495 Light Gray on the entire top surface, and the bottom surfaces are black. The leading edges of the rotor blades are a bare metal color.

AH-1Z - 168961

HMLA-169

Iwakuni 2017

The Academy 1/35 AH-1Z includes decals for SN47. At some time, the aircraft was assigned to LtCol JB “Gash” Lagoski and his name was put on the aircraft under the back seaters cockpit. His name and “Taking Care of Business” TCB artwork has been added to the sheet.



Aftermarket

Flight Line Resin has various ACMI pods in 1/35 and 1/48

Flying Leatherneck Scale Creations has DI-FMV in 1/35 and 1/48

Werner's Wings has 77gallon fuel tanks in 1/35th and 1/48