

Visit us online at
www.uswatersystems.com

US Water
systems.com

US Water Systems

Synergy Models 9000/9100/9500



Owners Manual

Models:

163-SS, 093-CWS-075, 093-CWS-100 & 140-95

REVISION # 1.0
REVISION DATE: May 23, 2016

US Water Systems Corporate Office
1209 Country Club Road
Indianapolis, IN 46234

Table of Contents

Unpacking / Inspection and Safety Guide	2
Proper Installation	3
Specifications	4
Equipment Configuration	6
Before Starting and Job Specifications	7
How The Water Softener Works/Where to Install the Softener	8
Softener Preparation	9
Brine Tank Installation	19
System Start-up	22
Control Valve Features/SXT Controller Features	23
SXT Programming	25
Diagnostics and Troubleshooting	32
9000 Control Dimensions	36
9100 Control Dimensions	37
9500 Control Dimensions	38
Water Conditioning Diagrams	39
9000/9500 Wiring Diagram	41
Warranty	42

Unpacking / Inspection

Be sure to check the entire softener for any shipping damage or parts loss. Also note damage to the shipping cartons. Contact US Water Systems at **1-800-608-8792** to report any shipping damage within 24 hours of delivery. Claims made after 24 hours may not be honored.

Safety Guide



For safety purposes, the information in this manual must be followed to minimize the risk of electric shock, property damage or personal injury.

- Check and comply with provincial / state and local codes. It may be mandatory that these codes/laws be followed.
- Use care when handling the water softening system. Do not turn upside down, drop, drag or set on sharp protrusions.
- The water softening system works on 120 volt-60 Hz electrical power. Be sure to use only the included transformer.
- Transformer must be plugged into an indoor 120 volt, grounded outlet only.
- Use clean water softening salts only, at least 99.5% pure. Extra Course Grade or Crystal salts are recommended. Do not use rock, block, granulated or ice cream making salts. They contain contaminants that could cause maintenance problems.
- Keep the salt lid in place on the softener unless servicing the unit or refilling with salt.
- **WARNING:** This system is not intended for treating water that is microbiologically unsafe or of unknown quality without adequate disinfection before or after the system. Contact US Water Systems for disinfection treatment equipment.

Proper Installation

This water softening system must be properly installed and located in accordance with the Installation Instructions before it is used or the warranty will be void.

Do not install or store where it will be exposed to temperatures below freezing or exposed to any type of weather. Water freezing in the system will break it. Do not attempt to treat water over 100°F.



32° - 100° F

Do not install in direct sunlight. Excessive sun or heat may cause distortion or other damage to non-metallic parts.



No Direct Sunlight

Properly ground to conform with all governing codes and ordinances.

Use only *lead-free solder and flux* for all sweat-solder connections, as required by state and federal codes.



Conform to all Governing Codes

Maximum allowable inlet water pressure is **125 psi**. If daytime pressure is over 80 psi, night time pressure may exceed the maximum. Use a pressure reducing valve (PRV) to reduce the pressure.



125 Max. PSI

Softener resins may degrade in the presence of chlorine or chloramines. If the feed water contains chlorine or chloramines, reduced life of the resin could occur. In these conditions, it is wise to consider purchasing a whole house carbon filter system with a chlorine reducing media. Contact US Water Systems for Chlorine and Chloramine removal equipment.



2 ppm Max. Chlorine & Chloramine

WARNING: Discard all unused parts and packaging material after installation. Small parts remaining after the installation could be a choke hazard.



Discard All Unused Material

Specifications

US WATER SYNERGY ALTERNATING WATER SOFTENER PROGRAMMING (Fleck 9100)					
Abbreviation	Parameter				
DF	Display Format	GAL			
VT	Valve Type	dF/1b			
CT	Control Type	FI (Immediate Regen)			
NT	Number of Tanks	2			
TS	Tank in Service	U1 or U2 (info only)			
Residential		Synergy Residential (9100)			
	Model Number	163-SS-10	163-SS-15	163-SS-20	163-SS-25
C	Capacity	25,000	37,000	50,000	63,000
H	Hardness	Feed Hardness + 5 GPG			
RS	Reserve Selection	RC			
SF	Safety Factor	0			
DO	Daily Override	14			
RT	Regen Time	2:00AM			
BW	Backwash	10			
BD	Brine Draw	60			
RR	Rapid Rinse	10			
BF	Brine Fill	8	10	7	9
FM	Flow Meter	t0.7	t0.7	t0.7	t0.7
	Size Cubic Feet	1	1.5	2	2.5
	Backwash Flow Control	2	2.4	3.5	4
	Brine Flow Control	0.5	0.5	1	1

US WATER COMMERCIAL TWIN ALTERNATING WATER SOFTENER PROGRAMMING (Fleck 9100)						
Abbreviation	Parameter					
DF	Display Format	GAL				
VT	Valve Type	dF/1b				
CT	Control Type	FI (Immediate Regen)				
NT	Number of Tanks	2				
TS	Tank in Service	U1 or U2 (info only)				
Commercial		US Water 3/4" Commercial (9100)				
	Model Number	093-CWS-075-22-TA	093-CWS-075-30-TA	093-CWS-075-45-TA	093-CWS-075-60-TA	093-CWS-075-75-TA
C	Capacity	18,500	25,000	37,000	50,000	63,000
H	Hardness	Feed Hardness + 5 GPG				
RS	Reserve Selection	RC				
SF	Safety Factor	0				
DO	Daily Override	14				
RT	Regen Time	2:00AM				
BW	Backwash	10				
BD	Brine Draw	60				
RR	Rapid Rinse	10				
BF	Brine Fill	6	8	10	7	9
FM	Flow Meter	t0.7	t0.7	t0.7	t0.7	t0.7
	Size Cubic Feet	0.75	1	1.5	2	2.5
	Backwash Flow Control	1.5	2	2.4	3.5	4
	Brine Flow Control	0.5	0.5	0.5	1	1

- Continuous operation at flow rates greater than the service flow rate may affect capacity and efficiency performance.
- The manufacturer reserves the right to make product improvements which may deviate from the specifications and descriptions stated herein, without obligation to change previously manufactured products or to note the change.
- The above capacity and flow rate specifications have not been validated by WQA.

Specifications

US WATER COMMERCIAL ALTERNATING WATER SOFTENER PROGRAMMING (Fleck 9000)					
Abbreviation	Parameter				
DF	Display Format	GAL			
VT	Valve Type	dF/1b			
CT	Control Type	FI (Immediate Regen)			
NT	Number of Tanks	2			
TS	Tank in Service	U1 or U2 (info only)			
Commercial		US Water 1" Commercial (9000)			
Model Number		093-CWS-100-30-TA	093-CWS-100-45-TA	093-CWS-100-60-TA	093-CWS-100-75-TA
C	Capacity	25,000	37,000	50,000	63,000
H	Hardness	Feed Hardness + 5 GPG			
RS	Reserve Selection	RC			
SF	Safety Factor	0			
DO	Daily Override	14			
RT	Regen Time	2:00AM			
BW	Backwash	10			
BD	Brine Draw	60			
RR	Rapid Rinse	10			
BF	Brine Fill	8	10	7	9
FM	Flow Meter	t0.7 or P1.0	t0.7 or P1.0	t0.7 or P 1.0	t0.7 or P1.0
Size Cubic Feet		1	1.5	2	2.5
Backwash Flow Control		2	2.4	3.5	4
Brine Flow Control		0.5	0.5	1	1

US WATER COMMERCIAL ALTERNATING WATER SOFTENER PROGRAMMING (Fleck 9500)					
Abbreviation	Parameter				
DF	Display Format	GAL			
VT	Valve Type	dF/1b			
CT	Control Type	FI (Immediate Regen)			
NT	Number of Tanks	2			
TS	Tank in Service	U1 or U2 (info only)			
Commercial		US Water 1.5" Commercial (9500)			
Model Number		140-95-120-M	140-95-150-M	140-95-210-M	140-95-300-M
C	Capacity	100,000	125,000	175,000	250,000
H	Hardness	Feed Hardness + 5 GPG			
RS	Reserve Selection	RC			
SF	Safety Factor	0			
DO	Daily Override	14			
RT	Regen Time	2:00AM			
BW	Backwash	10			
BD	Brine Draw	60			
RR	Rapid Rinse	10			
BF	Brine Fill	14	9	10	9
FM	Flow Meter	P1.5	P1.5	P1.5	P1.5
Size Cubic Feet		4	5	7	10
Backwash Flow Control		7	9	12	15
Brine Flow Control		1	2	2.4	4

Equipment Configuration

9000/9100 Equipment Configuration

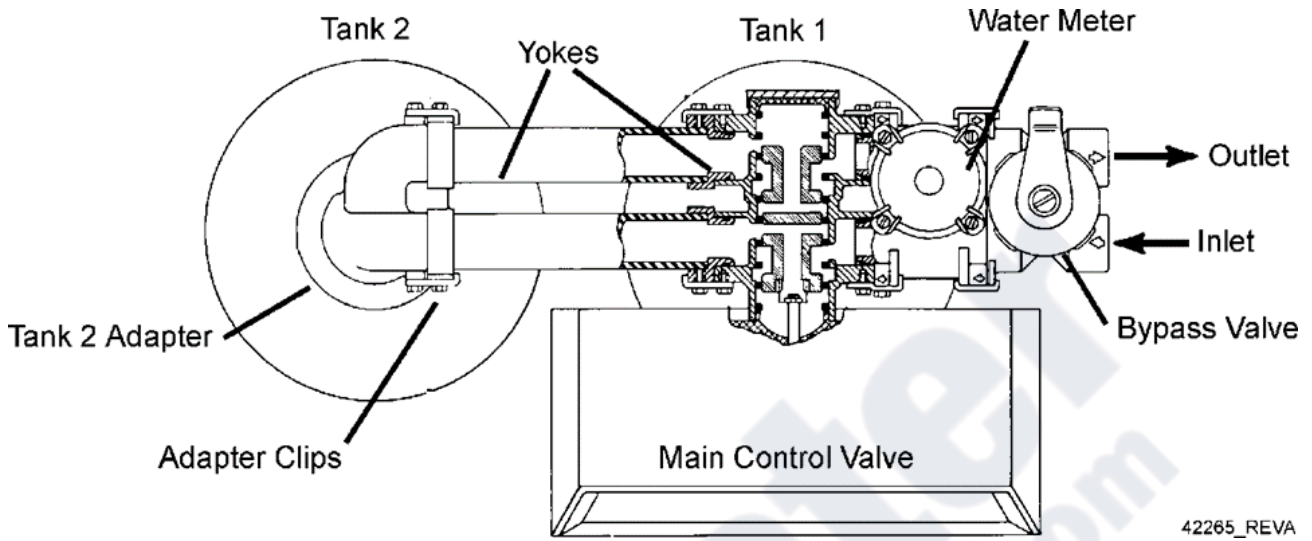

9500 Equipment Configuration

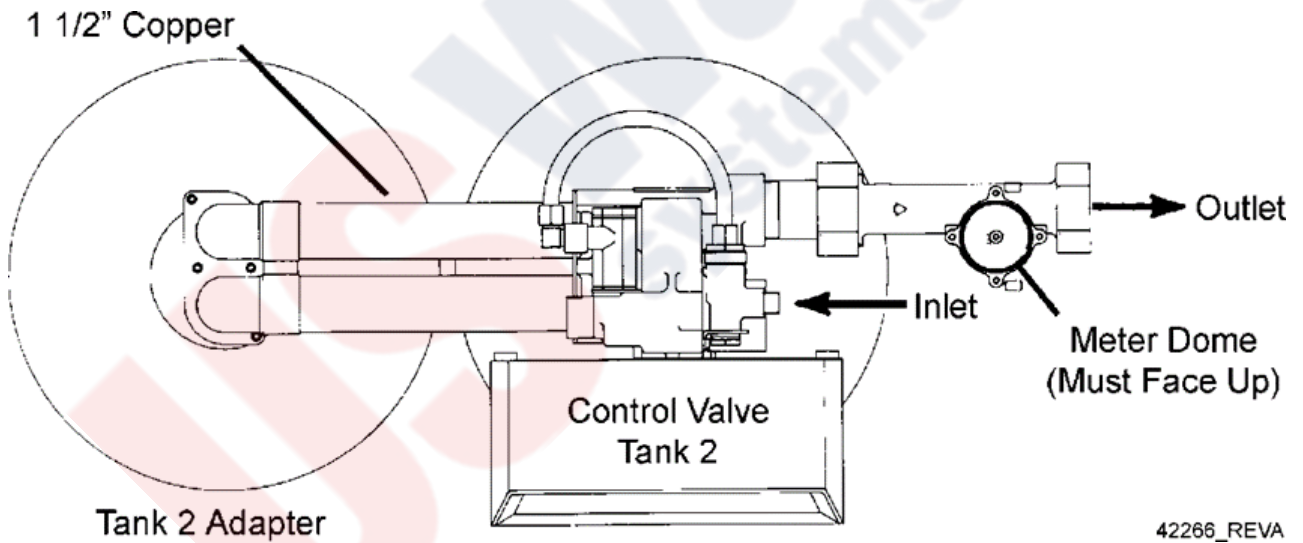

Before Starting Installation

Tools, Pipe, and Fittings, Other Materials

- Channel Locks
- Screwdriver
- Teflon tape
- Razor knife
- Two adjustable wrenches
- Additional tools may be required if modification to home plumbing is required.
- Plastic inlet and outlet fittings are included with the softener. To maintain full valve flow, 3/4" pipes to and from the softener fittings are recommended. The same, or larger, pipe size can be used as the water supply pipe, but the outlet piping should be the same as the inlet or smaller.
- Use copper, brass, or PEX pipe and fittings.
- Some codes may also allow PVC plastic pipe.
- ALWAYS install the included bypass valve, or a 3 shut-off valves "H" valve bypass manifold. Bypass valves allow the water to the softener to be bypassed for repairs if needed, but still have water in the house pipes.
- 5/8" OD drain line (not included) is needed for the valve drain.
- Extra Course Grade or Crystal water softener salt (not included) is needed to fill the cabinet or brine tank.



Job Specification Sheet

Model Number: _____

Water Test: Hardness _____ GPG, Iron _____ ppm

Capacity Per Unit: _____ Grains

Mineral Tank Size: _____ cu/ft, Diameter: _____ Height: _____

Brine Tank Size & Salt Setting per Regeneration: _____

Backwash: _____ Minutes

Brine and Slow Rinse: _____ Minutes

Rapid Rinse: _____ Minutes

Brine Tank Refill: _____ Minutes

Drain Line Flow Control: _____ gpm

Brine Refill Rate: _____ gpm

How The Water Softener Works

The principle behind water softening is simple chemistry. A water softener contains resin beads which hold electrically charged ions. When hard water passes through the softener, calcium and magnesium ions are attracted to the charged resin beads. The result is removal of calcium and magnesium ions which produces soft water.

This system is controlled with simple, user-friendly electronics displayed on a LCD screen.

Where To Install The Softener

- Place the softener as close as possible to the pressure tank (well system) or water meter (city water).
- Place the softener as close as possible to a floor drain, or other acceptable drain point (laundry tub, sump, standpipe, etc.).
- Connect the softener to the main water supply pipe **BEFORE** the water heater. **DO NOT RUN HOT WATER THROUGH THE SOFTENER.** Temperature of water passing through the softener must be less than 100 deg. F.
- Outside faucets and irrigation systems should be supplied with hard water prior to the water softener. If this is not possible, be sure to bypass the softener when watering grass or plants. Chronic soft water exposure can be detrimental to plant life.
- Do not install the softener in a place where it could freeze. **Damage caused by freezing is not covered by the warranty.**
- Put the softener in a place where water damage is least likely to occur if a leak develops. The manufacturer will not repair or pay for water damage.
- A 120 volt electric outlet is needed within 6 feet of the softener. The transformer has an attached 8 foot power cable. **Be sure the electric outlet and transformer are in an inside location, to protect from wet weather.**
- If installing in an outside location, you must take the steps necessary to assure the softener, installation plumbing, wiring, etc. are protected from the elements and contamination sources.
- **Keep the softener out of direct sunlight.** The sun's heat may soften and distort plastic parts.

Softener Preparation

Resin Tanks Preparation

WATER PRESSURE: A minimum of 20 pounds of water pressure is required for regeneration valve to operate effectively.

ELECTRICAL FACILITIES: An uninterrupted alternating current (A/C) supply is required. Please make sure your voltage supply is compatible with your unit before installation.

EXISTING PLUMBING: Condition of existing plumbing should be free from lime and iron buildup. Piping that is built up heavily with lime and/or iron should be replaced.

LOCATION OF SYSTEMS AND DRAIN: The system should be located close to a drain to prevent air breaks and back flow.

CAUTION: Water pressure is not to exceed 80 psi, water temperature is not to exceed 110°F (43°C), and the unit cannot be subjected to freezing conditions.

Resin Installation

1. Remove the resin tank from carton.
2. Verify the riser tube is centered in the bottom center of the tank. A flashlight may be necessary. There is an indentation in the bottom of the tank that will center the distributor tube. The distributor tube should be flush with the top of the tank when it is installed properly.



Softener Preparation

3. Place a piece of duct tape over the riser tube so no resin enters the riser while filling.

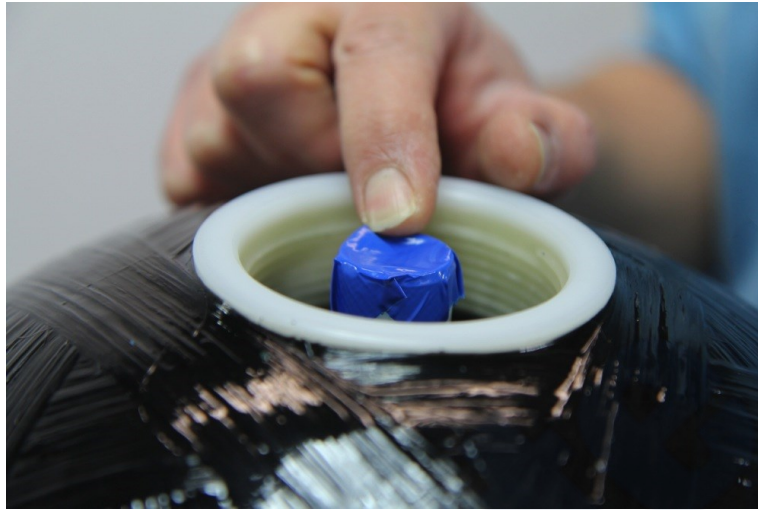

4. Use the Blue Funnel provided, to pour the softening resin into both tanks. Pour it evenly around the hole to ensure it is well distributed in the tank and pour slow enough, to keep from plugging the hole. A helper may be needed to hold the funnel during the filling process. It is recommended that a dust mask and safety goggles be worn to prevent possible injury. Equally divide the resin between both tanks. Pour all the resin sent with the system equally in each tank. US Water does not ship "extra" resin. Larger systems may have gravel shipped with the resin. If so, equally divide the gravel and pour it into each tank FIRST.



5. When the resin is installed move tanks side to side to settle the media. Remove the funnel and tape from the distributor tubes.

Softener Preparation

6. Lubricate the distributor o-ring seal and tank o-ring seal on the control valve. Install the upper basket by pushing in the slotted holes and turn it clockwise until it locks in place. Repeat these steps for the auxiliary tank adaptor.



NOTE: During cold weather it is recommended that the installer warm the valve to room temperature before operating.

Softener Preparation

7. Place the main control valve on one tank and the tank adapter on the second tank. Place the valve or adaptor over the distributor tube through the bottom of the upper basket. Slide the valve or adaptor down and thread the valve on the tank by turning it clockwise. Once the valve or adaptor is hand tight turn it an additional $\frac{1}{4}$ turn to snug it to the tank.



Softener Preparation



8. Connect the two tanks using the interconnect plumbing.

9000 Model: Install o-rings on all four connection points on the interconnect tubing. Lubricate the o-rings and make sure they are not twisted. Slide the interconnect tubes in the valve assembly and secure them using the retaining clips. Tighten the clips once the tubes are installed. When all four clips are in place the tanks are connected. It is recommended that a minimum of 1" clearance be between the tanks to allow room for tank expansion. These tubes should be level when installation is complete. If the tubes are not even a leak could occur at the o-ring seals. If one tank is high than the other the lower tank must be shimmed to ensure the interconnect tubes are level.

9100 Model: Install o-rings on all four connection points on the interconnect tubing. Lubricate the o-rings and make sure they are not twisted.

NOTE: If required, solder copper tubing for tank interconnection before assembling on the main control valve and tank adapter (9500 only). Maintain a minimum of 1" distance between tanks on final assembly. Plastic interconnect tubing doesn't require modification.

Softener Preparation

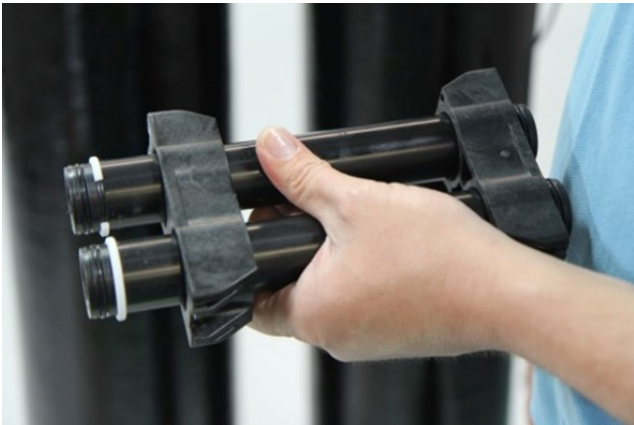

9. Slide the interconnect tubes in the valve assembly and tank adaptor. Then secure them using the retaining clips. Tighten the clips once the tubes are installed. When all four clips are in place the tanks are connected. It is recommended that a minimum of 1" clearance be between the tanks to allow room for tank expansion.



Softener Preparation

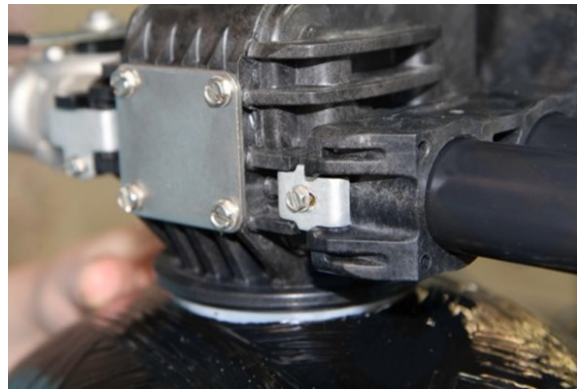
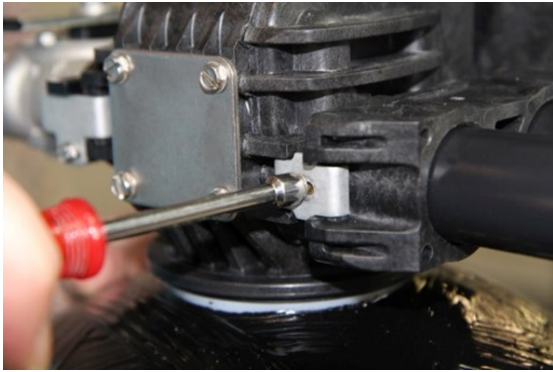

Softener Preparation



NOTE: These tubes should be level when installation is complete. If the tubes are not level or in a bind, a leak could occur at the o-ring seals. If one tank is high than the other the lower tank must be shimmed to ensure the interconnect tubes are level. The tanks and tubes should be close to level as possible.

9500 Model: Install o-rings on all four connection points on the interconnect tubing. Make sure all solder joints are completed and the tubes are cooled before installing the o-rings. Lubricate the o-rings and make sure they are not twisted. Slide the interconnect tubes in the valve assembly and tank adaptor. Then secure them using the retaining clips. Tighten the clips once the tubes are installed. When all four clips are in place the tanks are connected. It is recommended that a minimum of 1" clearance be between the tanks to allow room for tank expansion. These tubes should be level when installation is complete. If the tubes are not even a leak could occur at the o-ring seals. If one tank is high than the other the lower tank must be shimmed to ensure the interconnect tubes are level.

10. Attach the plumbing according to local codes.

9100 Model: The inlet and outlet pipes will attach to the 1" female threads on bypass valve. The bypass valve will be labeled with arrows. The inlet port will have an arrow pointing toward the unit and the outlet will have an arrow pointing away from the unit. If soldering is necessary it is recommended that solder joints closer than 6" to the unit be completed prior to screwing the pipes into the bypass. Excessive heat close to the bypass valve can damage the unit.



Softener Preparation

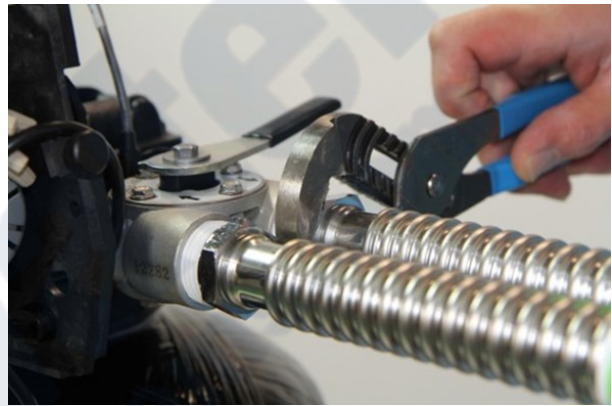
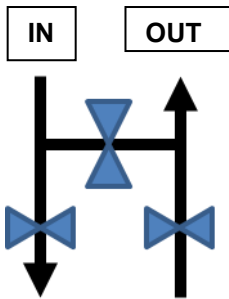
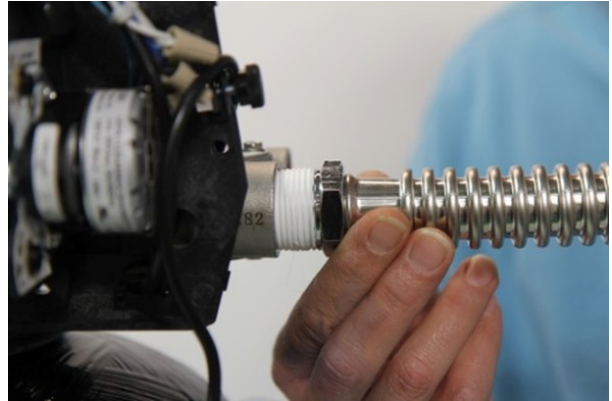

Figure: A

9000 Model: The inlet and outlet plumbing will be connected to the 1" female connections on the unit. If there is no bypass on the unit, a three valve bypass should be plumbed in to bypass the unit if necessary (Figure: A). There are arrows stamped in the connection points that indicate the inlet and outlet connections. The arrow pointing toward the unit is the inlet and the arrow pointing away from the unit is the outlet.

9500 Model: The inlet and outlet plumbing will be connected to the 1 1/2" female connections on the unit. A three valve bypass should be plumbed in to bypass the unit if necessary (Figure: A). The external meter will thread into the outlet port on the valve. There are arrows stamped in the plumbing connection points that indicate the inlet and outlet connections. The arrow pointing toward the unit is the inlet and the arrow pointing away from the unit is the outlet.

11. Solder joints near the drain must be done before connecting the Drain Line Flow Control fitting (DLFC). Leave at least 6" (152 mm) between the DLFC and solder joints when soldering pipes that are connected on the DLFC. Failure to do this could cause interior damage to DLFC.

Softener Preparation

12. Use only Teflon tape on the drain fitting threads. Two wrenches or channel locks may be needed to tighten the barbed fitting or hard plumbing fitting if tubing is not used. Be sure not to over tighten this fitting.

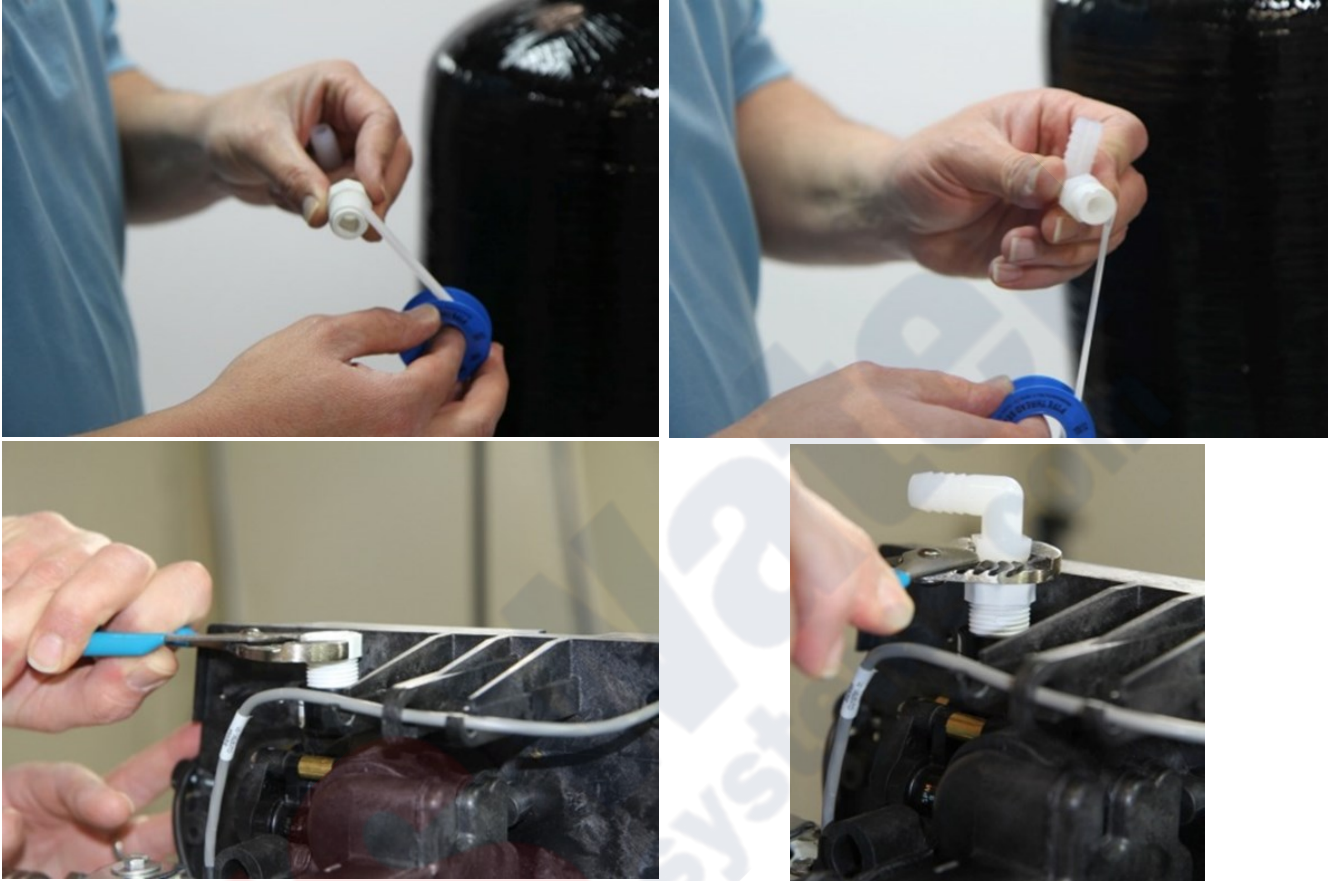

13. Once the fittings are installed and tight, push the 5/8" drain line on the barb and secure it using a hose clamp. This tube should be attached to a sanitary drain. An air gap fitting should be installed on the drain pipe where this tube will be connected (check local codes). If this is being conveyed to a floor drain, sink or sump pump be sure to maintain a proper air gap. Typically a 1" air gap is sufficient.

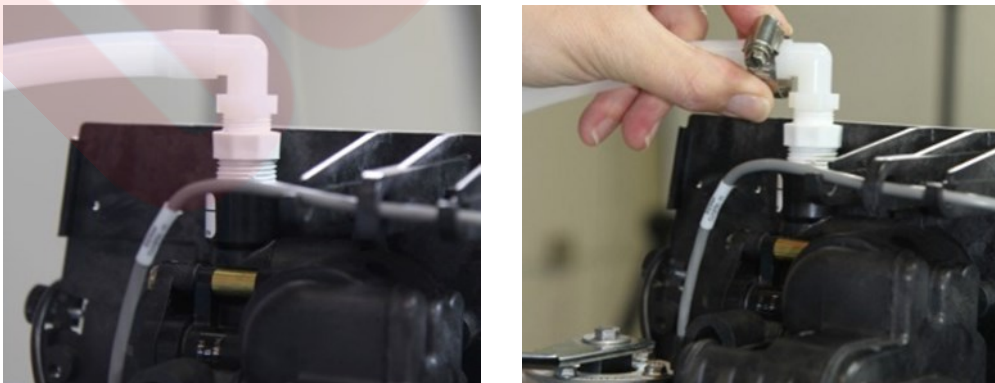

NOTE: Perform all plumbing according to local plumbing codes including the drain. — Use a 1/2" minimum pipe/tube size for the drain. — Use a 3/4" drain line for backwash flow rates that exceed 7 gpm or length that exceeds 20' (6 m).

Brine Tank Installation

NOTE: Be sure the floor under the salt storage tank is clean and level. Any debris can cause a leak when the tank is weighted down with salt and brine solution.

1. Connect the supplied 3/8" tubing to both brine connections. At the control valve place the nut over the tube, install the brass sleeve in the tube. Install the cone screen in brass insert. Install the plastic flange over the tube. Install the tube in the control valve and tighten the nut by turning it clockwise. Tighten it hand tight then snug it an additional $\frac{1}{4}$ to $\frac{1}{2}$ turn.

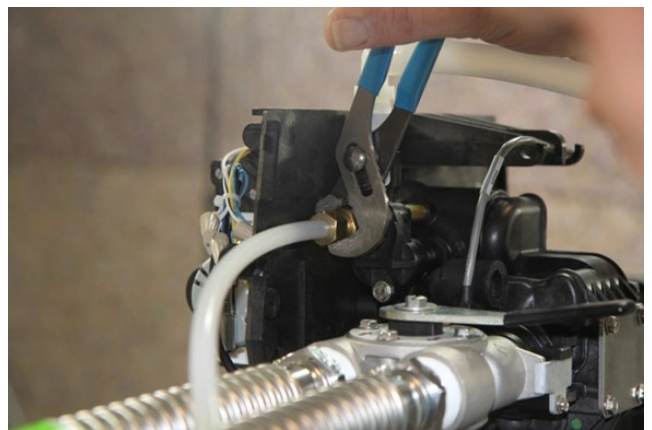
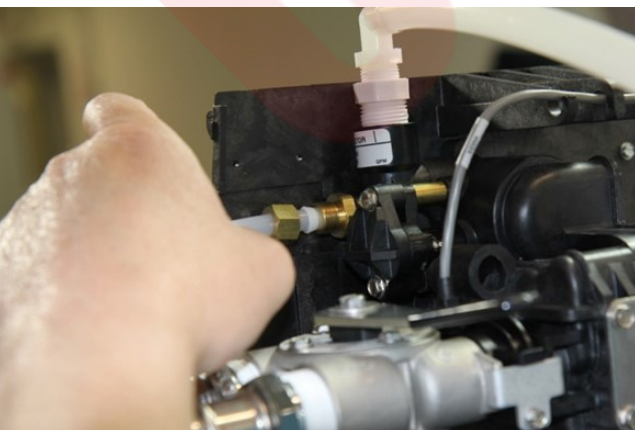
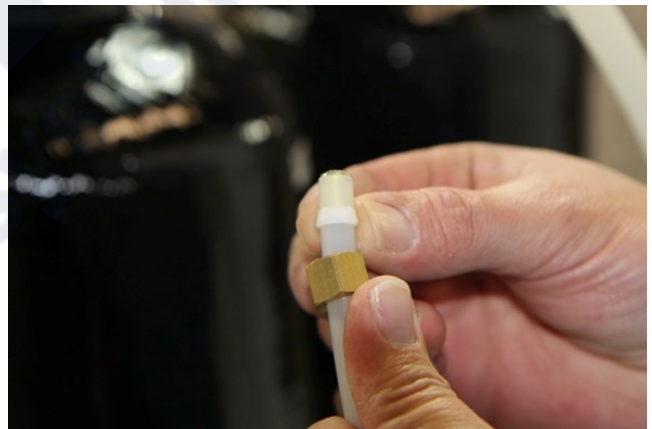

Brine Tank Installation

1. Now connect the brine line to the brine tank . Remove the cap on the white brine well in the tank and push the brine line through the hole in the side of the tank and brine well.



2. Remove the nut and sleeves from the brine safety valve in the brine well. BE CAREFUL not to drop the sleeves in the tank. Install the nut on the brine line first.



3. Install the "split" sleeve on the brine line with the tapered part facing the nut.



Brine Tank Installation

4. Now slide the “shoulder” sleeve on the brine line with the larger diameter “shoulder” facing the brine nut.



5. Be sure the tube stiffener is in place. It may be brass or plastic, either can be used. Push the brine line in the elbow on the brine safety valve in the brine well until it stops. Tighten the nut hand tight then turn it another 1/2 to 1 full turn with channel locks.



6. Pour in at least two bags of salt and 5 gallons of clean water.

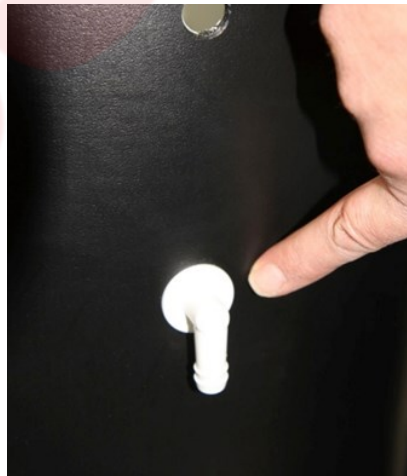

NOTE: There is a barb fitting on the side of the brine tank. This is used as an overflow and only is used if the brine tank overfills. This barb is for 1/2” tubing. If you elect to use tubing for this elbow, run it to a floor drain or sump pump.

Start Up Instructions

1. Place the unit in the Bypass position. There is a pointer on the bypass valve handle. This pointer should be pointing to "bypass" on the valve. When the bypass valve is in the bypass position the handle will bisect the plumbing connections.



2. Turn on the main water supply.
3. Open a cold soft water tap nearby and let water run a few minutes or until the system is free of foreign material (usually solder) resulting from the installation. Close the water tap when water runs clean.
4. Slowly place the bypass In Service position and let water flow into the mineral tank. Open the bypass in small increments until it is fully open. When water flow stops, slowly open a cold water tap nearby and let water run until air is purged from the unit. Preferably a garden spigot or bath tube. Then close tap once the water runs clear and there is no air in the system.

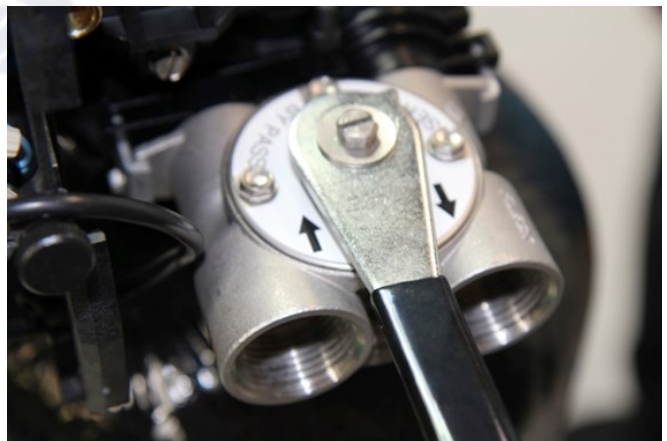
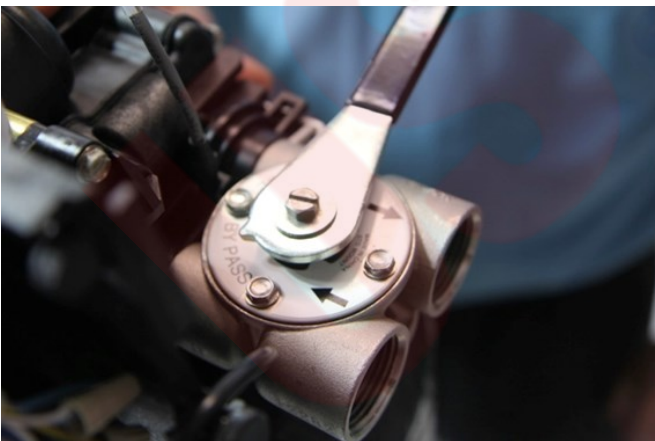

Control Valve Features

NOTE: Make all electrical connections according to codes.

Tank one (or U1) has the control valve and tank two (or U2) has the adapter.

There are indicators showing which position the control valve is in during Regeneration and which tank is In Service on the right side of the gear assembly.

1. Plug the valve into an approved power source.

NOTE: The valve position and tank in service will also be displayed on the control panel. If the unit is in the regeneration process the cycle will be shown and periodically it will flash to the tank in service. When the system is in the service position it will display the time of day and flash to the tank in service and the amount of gallons that are remaining before a regeneration of the tank in service is required.

SXT Controller Features

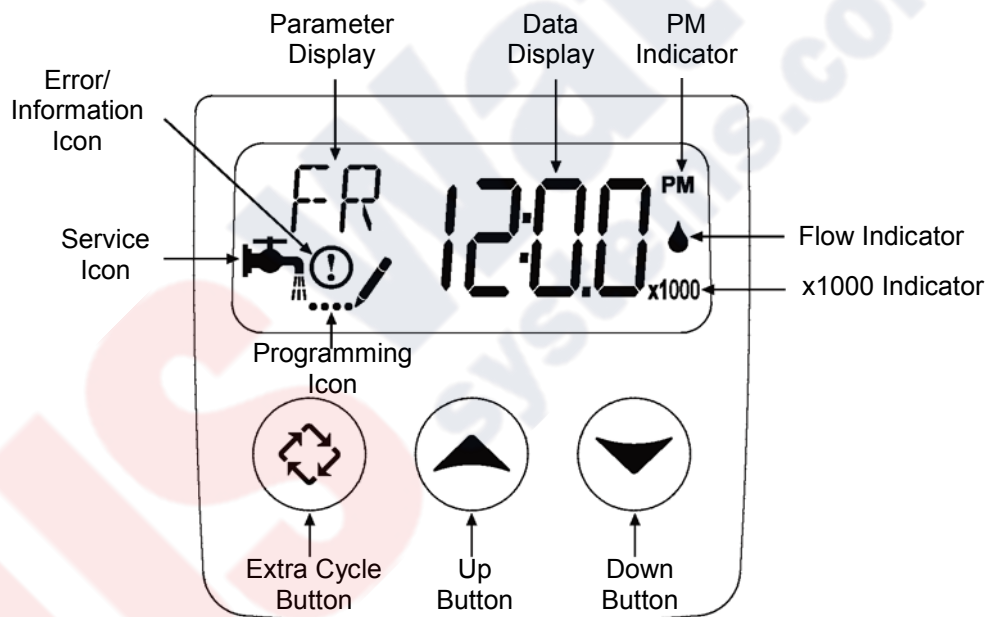

1. When in the service mode the service icon will be illuminated. If a delayed regeneration is initiated the service icon will blink.
2. The flow indicator icon will blink when water is being used.
3. When setting the time of day and delayed regeneration time, be sure the clock is in the correct 12 hour time cycle. When you are in the PM time cycle the PM icon will be illuminated. If it is not illuminated the clock is in the AM time cycle.
4. When the display is in the service mode it will flash from the time of day to the tank in service (U1 or U2) and then to the remaining capacity (in gallons)
5. When water is being used and the flow icon is blinking the remaining capacity value will decrease for each gallon used.
6. The service icon will be illuminated during programming or regeneration.

SXT Controller Features

7. The extra cycle button serves as an enter/return button when programming. The up and down arrows allow value changes in each parameter programming mode. Once the value is reached the extra cycle button can be pushed to save the value and move to the next parameter.
8. The extra cycle button also initiates immediate or delayed regenerations. Pushing and releasing it immediately triggers a delayed regeneration (will regenerate at the time specified under RT in the programming mode). The service icon will blink when a delayed regeneration is initiated. Pushing and holding the extra cycle button for 5 seconds will initiate an immediate regeneration. The service icon will blink and the valve will move to the first regeneration position and begin the process.
9. If the error icon is illuminated there is a problem with the unit and a service technician should be contacted.
10. The x1000 icon will illuminate when values are multiplied by 1000 (capacity setting).
11. The system will hold the values for up to 48 hours after a power outage. Outages exceeding 48 hours should have the programming values revisited. It is a good idea to write down the programming parameters/values so they are available if a reprogramming is required.

Setting the Time of Day

1. Press and hold either the Up or Down buttons until the programming icon replaces the service icon and the parameter display reads DO.
2. Adjust the displayed time with the Up and Down buttons.
3. When the desired time is set, press the Extra Cycle button to resume normal operation. The unit will also return to normal operation after 5 seconds if no buttons are pressed.

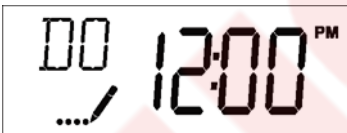

Queuing a Regeneration

Press the Extra Cycle button and release. The service icon will flash to indicate that regeneration is queued.

To cancel a queued regeneration, press the Extra Cycle button and release.

Regenerating Immediately

Press and hold the Extra Cycle button for five seconds.

Entering Master Programming Mode

Set the Time Of Day display to 12:01 P.M. Press the Extra Cycle button (to exit Setting Time of Day mode). Then press and hold the Up and Down buttons together until the programming icon replaces the service icon and the Display Format screen appears.

SXT Controller Features

Exiting Master Programming Mode

Press the Extra Cycle button to accept the displayed settings and cycle to the next parameter. Press the Extra Cycle button at the last parameter to save all settings and return to normal operation. The control will automatically disregard any programming changes and return to normal operation if it is left in Master Programming mode for 5 minutes without any keypad input.

Resets

Soft Reset: Press and hold the Extra Cycle and Down buttons for 25 seconds while in normal Service mode. This resets all parameters to the system default values, except the volume remaining in meter immediate or meter delayed systems and days since regeneration in the time clock system.

Master Reset: Hold the Extra Cycle button while powering up the unit. This resets all of the parameters in the unit. Check and verify the choices selected in Master Programming Mode.

SXT Programming

NOTE: THE HIGHLIGHTED VALUES ARE THE SELECTIONS THAT SHOULD BE MADE. SOME PARAMETERS WILL REFER TO THE SETTINGS CHART FOR VALUES.

1. Display Format (Display Code DF)

This is the first screen that appears when entering Master Programming Mode. The Display Format setting specifies the unit of measure that will be used for volume and how the control will display the Time of Day. This option setting is identified by “DF” in the upper left hand corner of the screen. There are three possible settings:

Display Format Setting	Unit of Volume	Time Display
GAL	U.S. Gallons	12-Hour AM/PM
Ltr	Liters	24-Hour



2. Valve Type (Display Code VT)

Press the Extra Cycle button. Use this display to set the Valve Type. The Valve Type setting specifies the type of cycle that the valve follows during regeneration. Note that some valve types require that the valve be built with specific subcomponents. Ensure the valve is configured properly before changing the Valve Type setting. This option setting is identified by “VT” in the upper left hand corner of the screen. There are 5 possible settings:

Abbreviation	Parameter
dF1b	Standard Downflow/Upflow, Single Backwash
dF2b	Standard Downflow/Upflow, Double Backwash
Filtr	Filter
UFbd	Upflow Brine First
8500	TwinFlo 100
Othr	Other

SXT Programming

3. Control Type (Display Code CT)

Press the Extra Cycle button. Use this display to set the Control Type. This specifies how the control determines when to trigger regeneration. For details on how the various options function, refer to the “Timer Operation” section of this service manual. This option setting is identified by “CT” in the upper left hand corner of the screen. There are four possible settings:

Meter Delayed:	Fd
Meter Immediate:	FI
Time Clock:	tc
Day of Week:	dAY

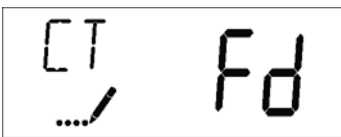

4. Number of Tanks (Display Code NT)

Press the Extra Cycle button. Use this display to set the Number of Tanks in your system. This option setting is identified by “NT” in the upper left hand corner of the screen. There are two possible settings:

Single Tank System	1
Two-Tank System	2

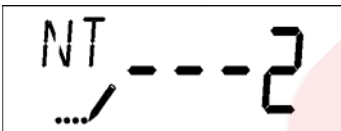

5. Tank in Service (Display Code TS)

Press the Extra Cycle button. Use this display to set whether tank one or tank two is in service. This option setting is identified by “TS” in the upper left hand corner of the screen. This parameter is only available if the number of tanks has been set to 2. There are two possible settings:

Tank One in Service: U1 Tank Two in Service: U2

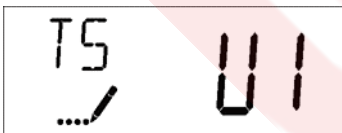

NOTE: NO CHANGES NECESSARY ON THIS PARAMATER

SXT Programming

6. Unit Capacity (Display Code C)

Press the Extra Cycle button. Use this display to set the Unit Capacity. This setting specifies the treatment capacity of the system media. Enter the capacity of the media bed in grains of hardness when configuring a softener system, and in the desired volume capacity when configuring a filter system. This option setting is identified by “C” in the upper left hand corner of the screen. The Unit Capacity parameter is only available if the control type has been set to one of the metered options. Use the Up and Down buttons to adjust the value as needed.

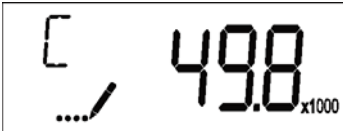

Range: 1-999,900 gallons (100-9,999,000 Liters)

Use the following chart to determine your capacity setting.

System Size	Low Salt Settings		Medium Salt Settings		High Salt Settings	
	Capacity Setting	Brine Fill (mins.)	Capacity Setting	Brine Fill (mins.)	Capacity Setting	Brine Fill (mins.)
26,000 Grain	15,000	4	18,000	6	24,000	8
35,000 Grain	20,000	4	25,000	8	30,000	10
53,000 Grain	30,000	6	37,000	10	45,000	14
70,000 Grain	40,000	8	50,000	16	60,000	20
88,000 Grain	50,000	10	63,000	18	75,000	25
105,000 Grain	60,000	12	75,000	20	90,000	30
140,000 Grain	80,000	16	100,000	28	120,000	40

7. Feed Water Hardness (Display Code H)

Press the Extra Cycle button. Use this display to set the feed water hardness. Enter the feed water hardness in grains per unit volume for softener systems, or 1 for filter systems. This option setting is identified by “H” in the upper left hand corner of the screen. The feed water hardness parameter is only available if the control type has been set to one of the metered options. Use the Up and Down buttons to adjust the value as needed.

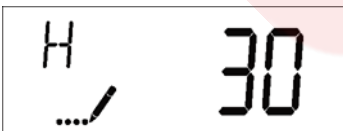

Range: 1-199 hardness

NOTE: The hardness level should be set 5 GPG above the actual water feed hardness. The hardness level from the original feed water test will either be expressed in GPG (grains per gallon) or ppm/mg/L (parts per million/milligrams per liter). If the reading is in ppm/mg/L, then divide that value by 17.1 to get GPG. This system only allows hardness inputs in GPG

SXT Programming

8. Reserve Selection (Display Code RS)

Press the Extra Cycle button. Use this display to set the Reserve Selection. Use this display to select the type of reserve to be used in your system. This setting is identified by "RS" in the upper left-hand corner of the screen. The reserve selection parameter is only available if the control type has been set to one of the metered options. There are two possible settings.

SF	Safety Factor
RC	Fixed Reserve Capacity

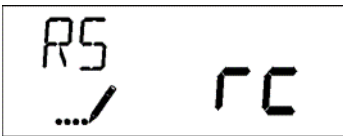

9. Fixed Reserve Capacity (Display Code RC)

Press the Extra Cycle button. Use this display to set the Reserve Capacity. This setting specifies a fixed volume that will be held as a reserve. The reserve capacity cannot be set to a value greater than one-half of the calculated system capacity. The reserve capacity is a fixed volume and does not change if the unit capacity or feedwater hardness is changed. This option setting is identified by "RC" in the upper left-hand corner of the screen. Use the Up and Down buttons to adjust the value as needed.

Range: 0-half the calculated capacity

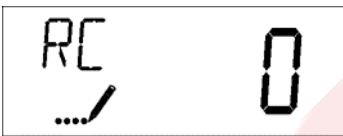

NOTE: There is no need to set a reserve capacity on a twin alternating system. Leave the RC set at 0.

10. Day Override (Display Code DO)

Press the Extra Cycle button. Use this display to set the Day Override. This setting specifies the maximum number of days between regeneration cycles. If the system is set to a timer-type control, the day override setting determines how often the system will regenerate. A metered system will regenerate regardless of usage if the days since last regeneration cycle equal the day override setting. Setting the day override value to "OFF" disables this function. This option setting is identified by "DO" in the upper left hand corner of the screen. Use the Up and Down buttons to adjust the value as needed.

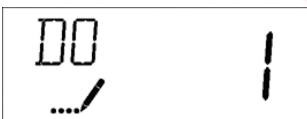

Range: Off-99 days

This will most likely be set at 14 days unless you take vacations lasting more than two weeks. Most households will eclipse the gallon capacity prior to the override engaging. However, if you are gone for two weeks it is a good idea to set this at 10 days so it regenerates and is fresh when you return. Water standing in the system for longer than 14 days can become stagnant.

SXT Programming

11. Regeneration Time

Press the Extra Cycle button. Use this display to set the Regeneration Time. This setting specifies the time of day the control will initiate a delayed, manually queued, or day override triggered regeneration. This option setting is identified by “RT” in the upper left hand corner of the screen. Use the Up and Down buttons to adjust the value as needed.



This feature is only used when a delayed regeneration is initiated.

12. Regeneration Cycle Step Times

Press the Extra Cycle button. Use this display to set the Regeneration Cycle Step Times. The different regeneration cycles are listed in sequence based on the valve type selected for the system, and are identified by an abbreviation in the upper left-hand corner of the screen. The abbreviations used are listed below. If the system has been configured with the “OTHER” valve type, the regeneration cycles will be identified as R1, R2, R3, R4, R5, and R6. Each cycle step time can be set from 0 to 199 minutes. Setting a cycle step time to 0 will cause the control to skip that step during regeneration, but keeps the following steps available. Use the Up and Down buttons to adjust the value as needed. Press the Extra Cycle button to accept the current setting and move to the next parameter.

Abbreviation	Cycle Step
BW	Backwash 10 Mins
BD	Brine Draw 60 Mins
RR	Rapid Rinse 10 Mins.
BF	Brine Fill (see chart)



Range: 0-199 minutes

This setting is determined by the chart used for the capacity setting. Input the number of minutes that corresponds to the capacity setting that was chosen previously.

SXT Programming

System Size	Low Salt Settings		Medium Salt Settings		High Salt Settings	
	Capacity Setting	Brine Fill (mins.)	Capacity Setting	Brine Fill (mins.)	Capacity Setting	Brine Fill (mins.)
26,000 Grain	15,000	4	18,000	6	24,000	8
35,000 Grain	20,000	4	25,000	8	30,000	10
53,000 Grain	30,000	6	37,000	10	45,000	14
70,000 Grain	40,000	8	50,000	16	60,000	20
88,000 Grain	50,000	10	63,000	18	75,000	25
105,000 Grain	60,000	12	75,000	20	90,000	30
140,000 Grain	80,000	16	100,000	28	120,000	40

13. Flow Meter Type (Display Code FM)

Press the Extra Cycle button. Use this display to set the type of flow meter connected to the control. This option setting is identified by “FM” in the upper left-hand corner of the screen. Use the Up and Down buttons to select one of the 7 available settings.

t0.7	Fleck 3/4" Turbine Meter
P0.7	Fleck 3/4" Paddle Wheel Meter
t1.0	Fleck 1" Turbine Meter
P1.0	Fleck 1" Paddle Wheel Meter
t1.5	Fleck 1 1/2" Turbine Meter
P1.5	Fleck 1 1/2" Paddle Wheel Meter
P2.0	Fleck 2" Paddle Wheel Meter
GEn	Generic/Other Meter



THE 9500 VALVE WILL USE “t1.5” FOR THIS SETTING.

14. End of Master Programming Mode

Press the Extra Cycle button to save all settings and exit Master Programming Mode

SXT Programming

USER PROGRAMMING MODE

User Programming Mode Options		
Abbreviation	Parameter	Description
DO	Day Override	The timer's day override setting
RT	Regeneration Time	The time of day that the system will regenerate (meter delayed, timeclock, and day-of-week systems)
H	Feed Water Hardness	The hardness of the inlet water - used to calculate system capacity for metered systems
RC or SF	Reserve Capacity	The fixed reserve capacity
CD	Current Day	The current day of week

NOTE: Some items may not be shown depending on timer configuration. The timer will discard any changes and exit User Mode if any button is not pressed for sixty seconds.

User Programming Mode Steps

1. Press the Up and Down buttons for five seconds while in service, and the time of day is NOT set to 12:01 PM.
2. Use this display to adjust the Day Override. This option setting is identified by "DO" in the upper left hand corner of the screen.

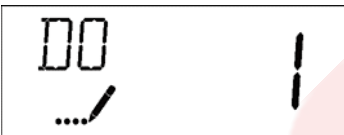

3. Press the Extra Cycle button. Use this display to adjust the Regeneration Time. This option setting is identified by "RT" in the upper left hand corner of the screen.

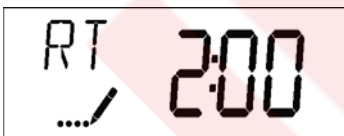

4. Press the Extra Cycle button. Use this display to adjust the Feed Water Hardness. This option setting is identified by "H" in the upper left hand corner of the screen.

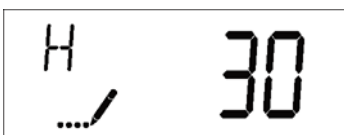

Range: 1-199 hardness

SXT Programming

USER PROGRAMMING MODE

- Press the Extra Cycle button. Use this display to adjust the Fixed Reserve Capacity. This option setting is identified by "RC" or "SF" in the upper left-hand Corner of the screen.



- Press the Extra Cycle button. Use this display to set the Current Day of the Week. This option setting is identified by "CD" in the upper left hand corner of the screen.

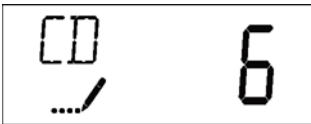

- Press the Extra Cycle button to end User Programming Mode.

Diagnostics and Troubleshooting

Diagnostic Programming Mode Options

Abbreviation	Parameter	Description
FR	Flow Rate	Displays the current outlet flow rate
PF	Peak Flow Rate	Displays the highest flow rate measured since the last regeneration
HR	Hours in Service	Displays the total hours that the unit has been in service
VU	Volume Used	Displays the total volume of water treated by the unit
RC	Reserve Capacity	Displays the system's reserve capacity calculated from the system capacity, feed-water hardness, and safety factor
SV	Software Version	Displays the software version installed on the controller

NOTE: Some items may not be shown depending on timer configuration. The timer will exit Diagnostic Mode after 60 seconds if no buttons are pressed. Press the Extra Cycle button to exit Diagnostic Mode at any time.

Diagnostic Programming Mode Steps

- Press the Up and Extra Cycle buttons for five seconds while in service.
- Use this display to view the current Flow Rate. This option setting is identified by "FR" in the upper left hand corner of the screen.

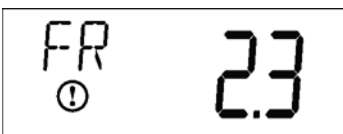

Diagnostics and Troubleshooting

3. Press the Up button. Use this display to view the Peak Flow Rate since the last regeneration cycle. This option setting is identified by "PF" in the upper left hand corner of the screen.

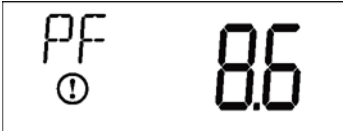

4. Press the Up button. Use this display to view the Hours in Service since the last regeneration cycle. This option setting is identified by "HR" in the upper left hand corner of the screen.

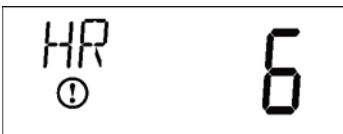

5. Press the Up button. Use this display to view the Volume Used since the last regeneration cycle. This option setting is identified by "VU" in the upper left hand corner of the screen.

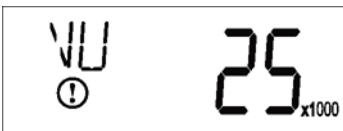

6. Press the Up button. Use this display to view the Reserve Capacity. This option setting is identified by "RC" in the upper left hand corner of the screen.



7. Press the Up button. Use this display to view the Software Version. This option setting is identified by "SV" in the upper left hand corner of the screen.



Press the Extra Cycle button to end Diagnostic Programming Mode.

Diagnostics and Troubleshooting

Problem	Cause	Correction
1. Water conditioner fails to regenerate.	A. Electrical service to unit has been interrupted	A. Assure permanent electrical service (check fuse, plug, pull chain, or switch)
	B. Control is defective.	Replace Control.
	Power failure.	C. Reset time of day.
2. Hard water.	A. By-pass valve is open.	A. Close by-pass valve.
	B. No salt is in brine tank.	Add salt to brine tank and maintain salt level above water level.
	Injector screen plugged.	C. Clean injector screen.
	D. Insufficient water flowing into brine tank.	D. Check brine tank fill time and clean brine line flow control if plugged.
	E. Hot water tank hardness.	E. Repeated flushings of the hot water tank is required.
	F. Leak at distributor tube.	F. Make sure distributor tube is not cracked. Check O-ring and tube pilot.
	G. Internal valve leak.	G. Replace seals and spacers and/or piston.
3. Unit used too much salt.	A. Improper salt setting.	A. Check salt usage and salt setting.
	B. Excessive water in brine tank.	B. See problem 7.
4. Loss of water pressure.	A. Iron buildup in line to water conditioner.	A. Clean line to water conditioner.
	B. Iron buildup in water conditioner.	Clean control and add mineral cleaner to mineral bed. Increase frequency of regeneration.
	Inlet of control plugged due to foreign material broken loose from pipes by recent work done on plumbing system.	C. Remove piston and clean control.
5. Loss of mineral through drain line.	A. Air in water system.	A. Assure that well system has proper air eliminator control. Check for dry well condition.
	B. Improperly sized drain line flow control.	B. Check for proper drain rate.
6. Iron in conditioned water.	A. Fouled mineral bed.	A. Check backwash, brine draw, and brine tank fill. Increase frequency of regeneration. Increase backwash time.
7. Excessive water in brine tank.	A. Plugged drain line flow control.	A. Clean flow control.
	B. Plugged injector system.	Clean injector and screen.
	Timer not cycling.	C. Replace timer.
	D. Foreign material in brine valve.	D. Replace brine valve seat and clean valve.
	E. Foreign material in brine line flow control.	E. Clean brine line flow control.

Diagnostics and Troubleshooting

Problem	Cause	Correction
8. Softener fails to draw brine.	A. Drain line flow control is plugged.	A. Clean drain line flow control.
	B. Injector is plugged.	Clean injector
	Injector screen plugged.	C. Clean screen.
	D. Line pressure is too low.	D. Increase line pressure to 20 P.S.I.
	E. Internal control leak	E. Change seals, spacers, and piston assembly.
	F. Service adapter did not cycle.	F. Check drive motor and switches.
9. Control cycles continuously.	A. Misadjusted, broken, or shorted switch.	A. Determine if switch or timer is faulty and replace it, or replace complete power head.
10. Drain flows continuously.	A. Valve is not programming correctly.	A. Check control program and positioning of control. Replace power head assembly if not positioning properly.
	B. Foreign material in control.	Remove power head assembly and inspect bore. Remove foreign material and check control in various regeneration positions.
	Internal control leak.	C. Replace seals and piston assembly.

9000 Control Dimensions

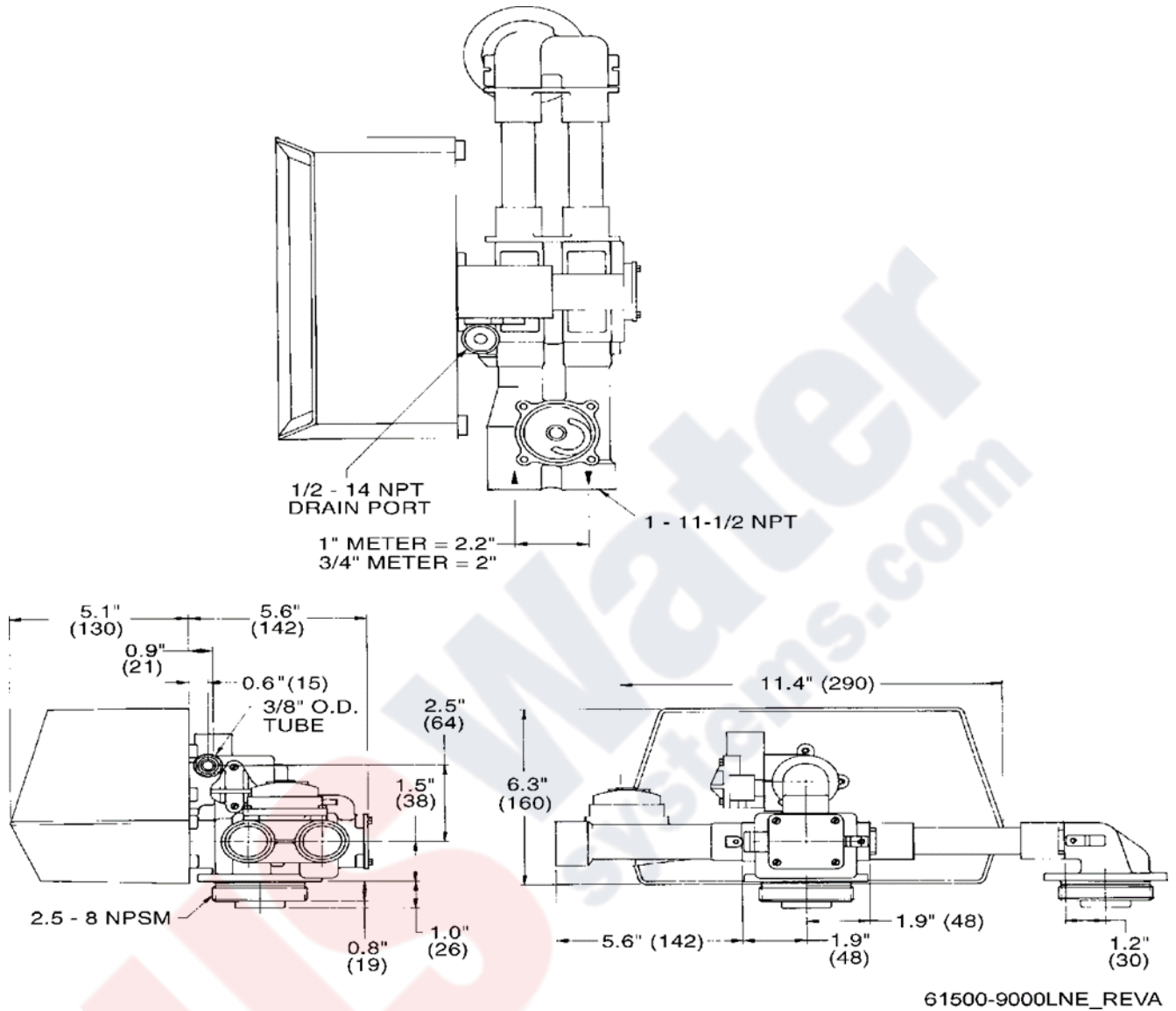

9100 Control Dimensions

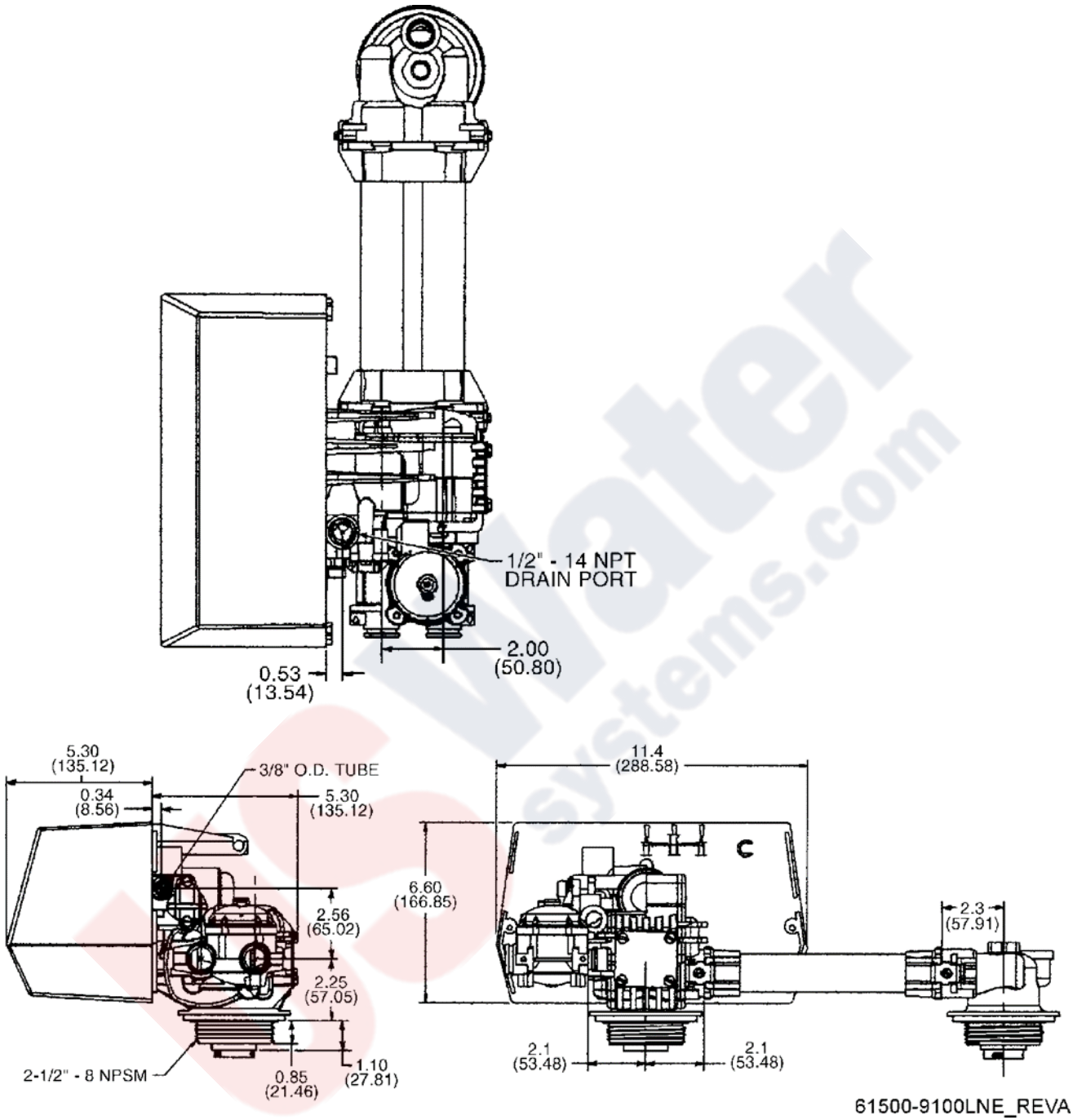

9500 Control Dimensions

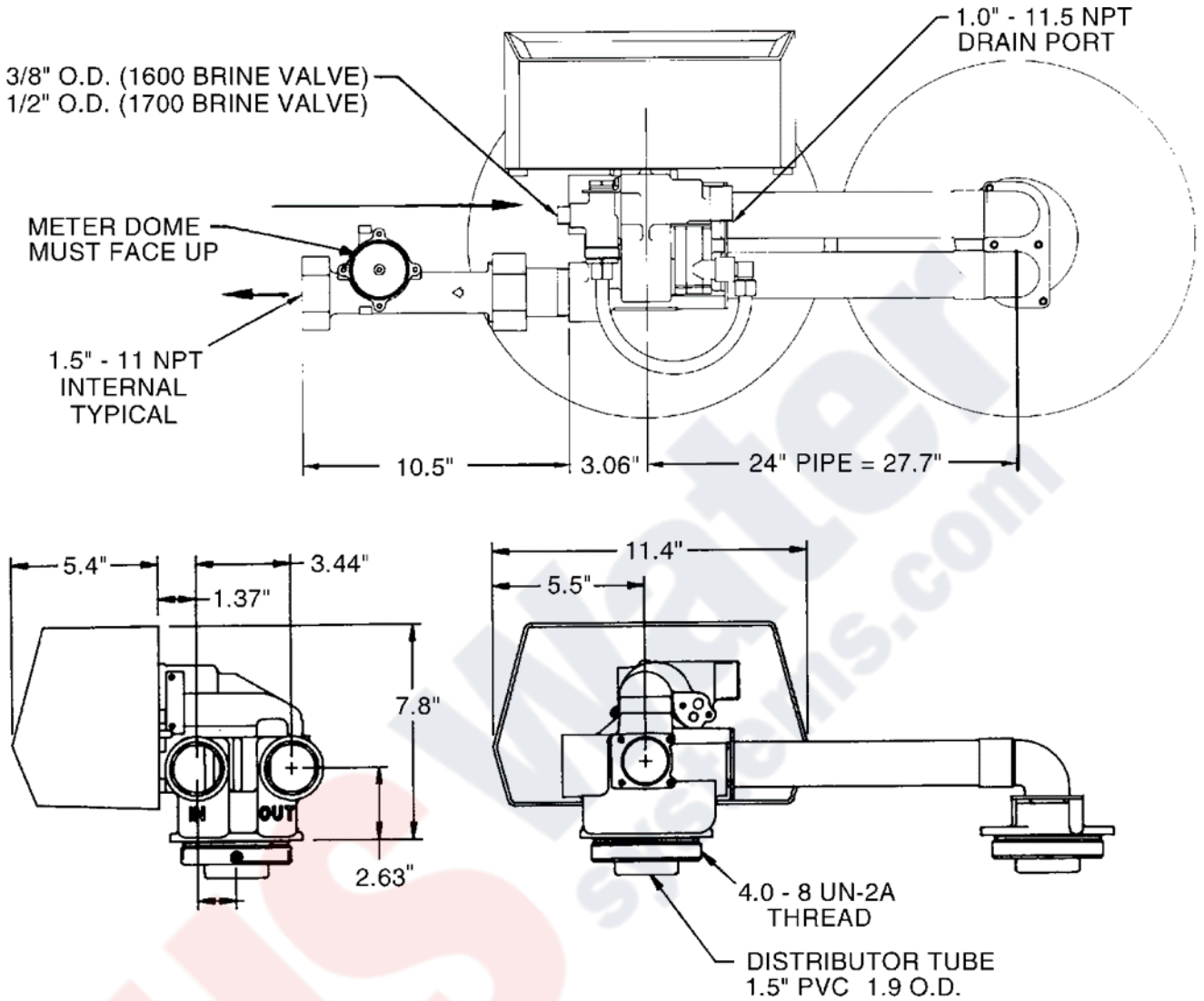

61500-9500LNE_REVA

Water Conditioner Flow Diagrams

In Service Position

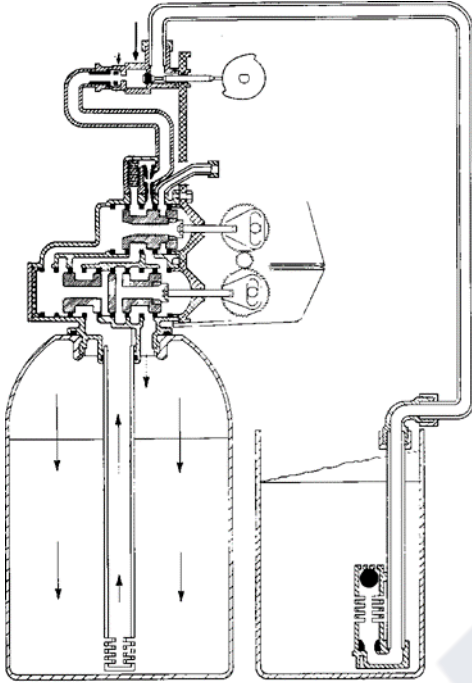

**Tanks Switching Position
(Meter Initiated Regeneration)**

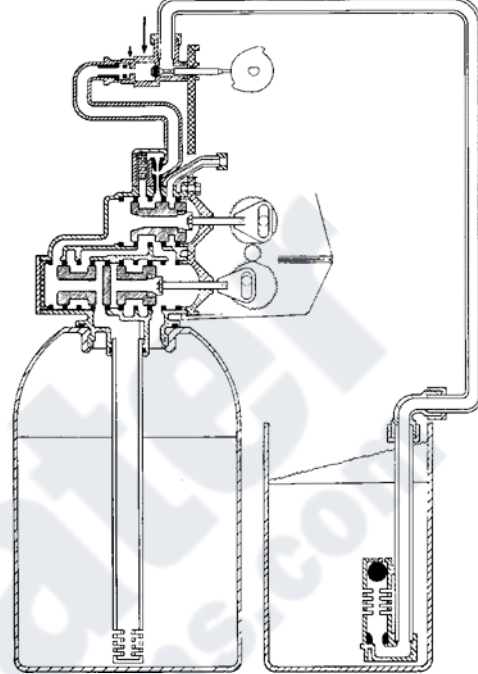

Backwash Position

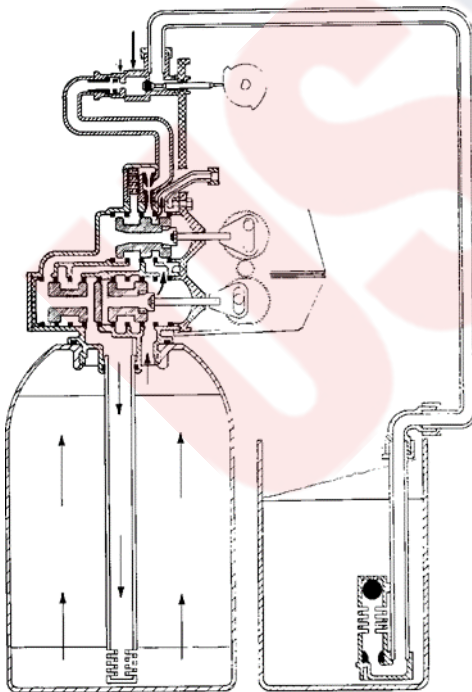

Brine Draw Position

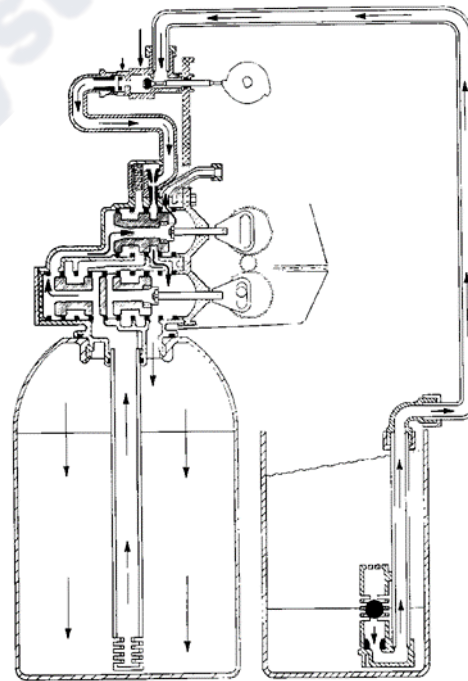

Water Conditioner Flow Diagrams

Slow Rinse Position

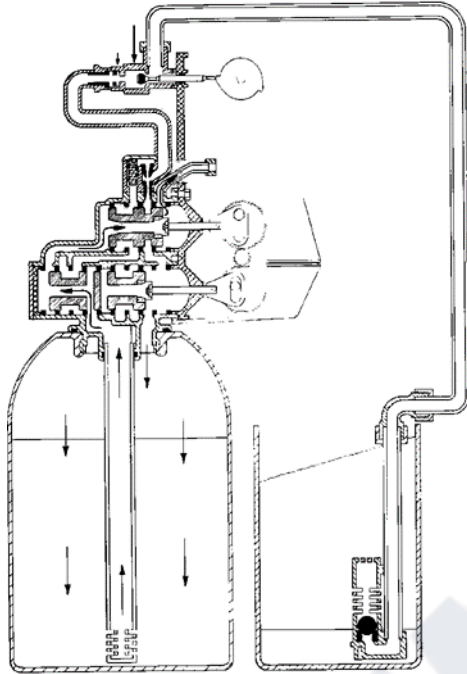

Rapid Rinse Position

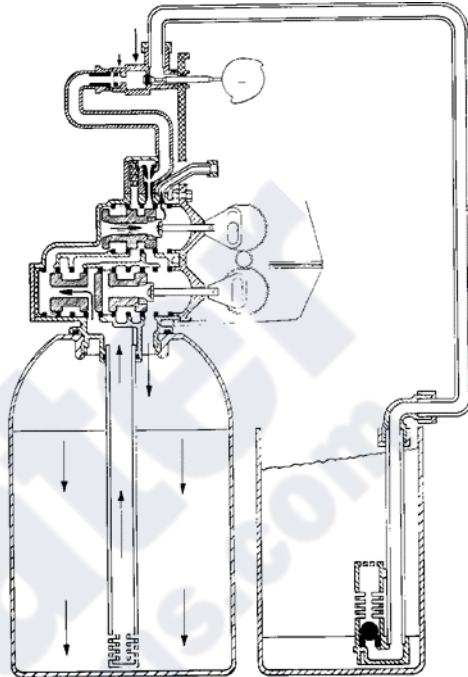

Brine Tank Fill Position

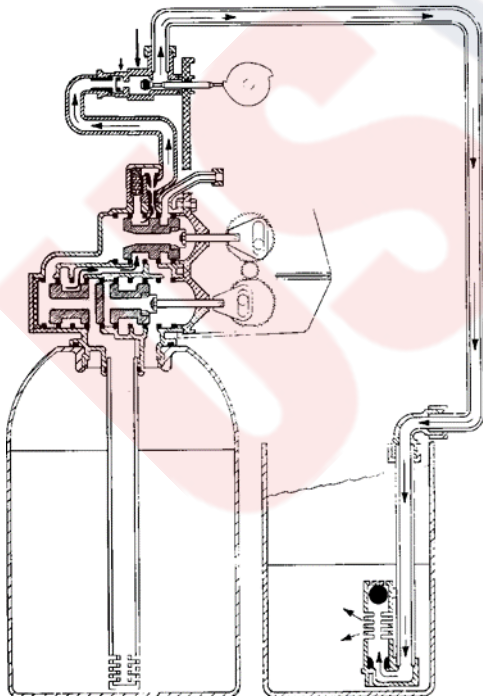

In Service Position, Tanks Switched

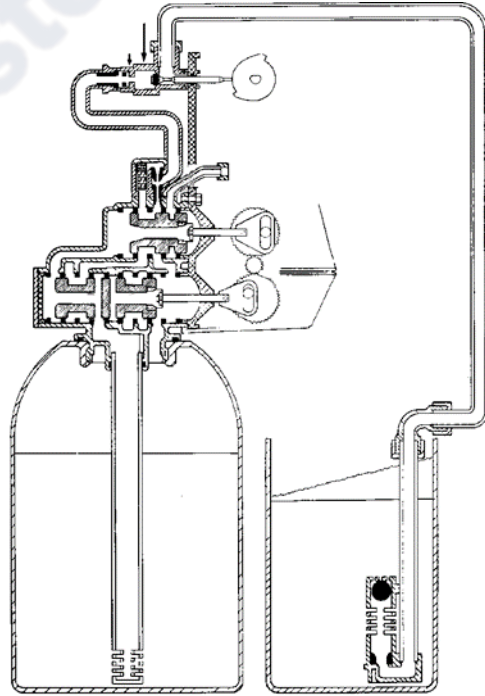

9000/9500 Wiring

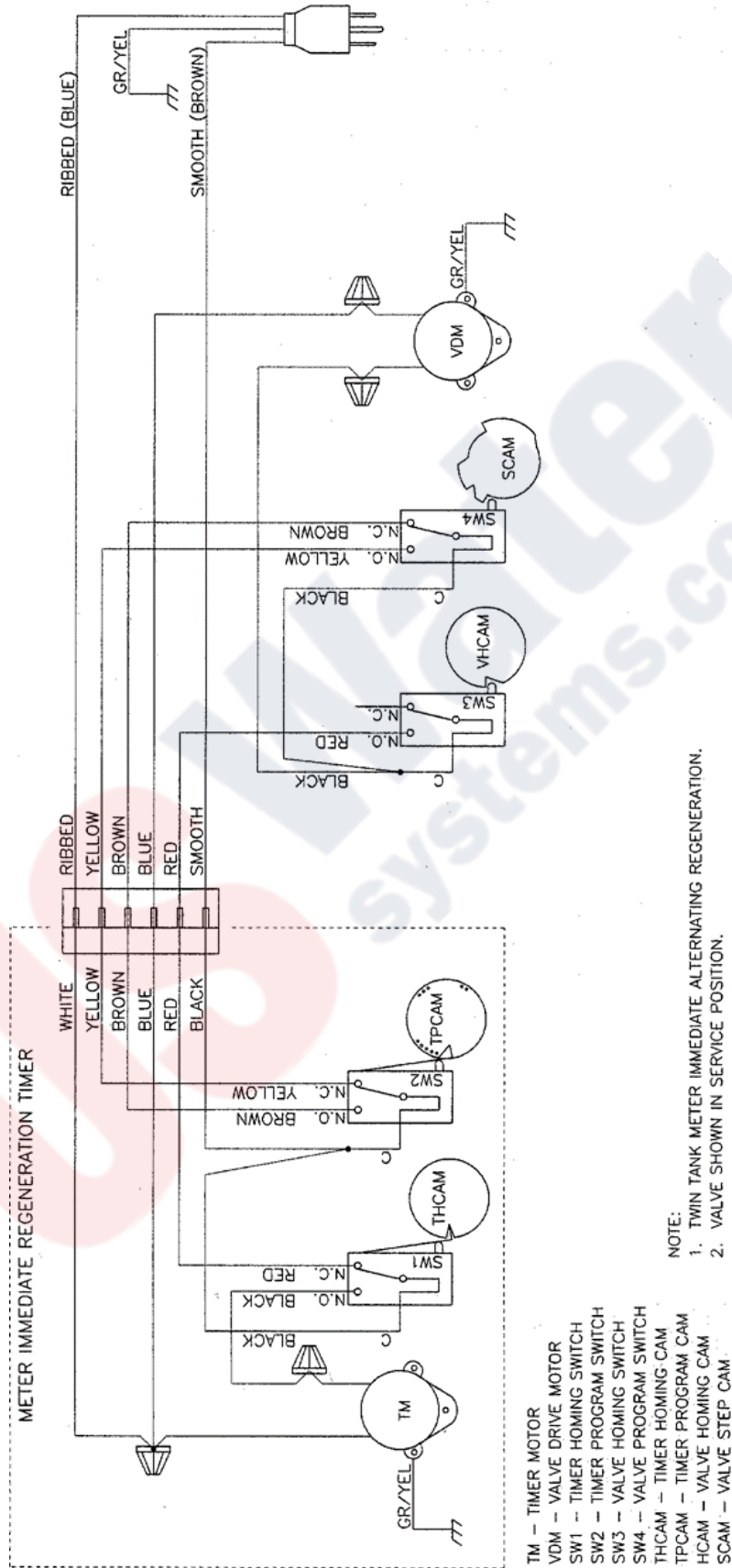

WARRANTY

US Water Systems warrants that your new water conditioner is built of quality material and workmanship. When properly installed and maintained, it will give years of trouble free service.

Commercial and Residential Five Year Valve and Electronics Guarantee

US Water Systems will replace the valve or electronics if either fails within (5) five years from date of manufacture, as indicated by the serial number, provided the failure is due to a defect in material or workmanship. The only exception shall be when proof of purchase or installation is provided and then the warranty period shall be from the date thereof. Internal control valve parts will not be covered. Systems used to remove iron, manganese or with very high chlorine concentrated feed waters should have additional equipment to protect the softener.

Commercial Five Year Warranty on Resin Tank and Brine Tank

US Water Systems will provide a replacement resin tank or brine tank to any original equipment purchaser in possession of the US Water Commercial water softener that fails for (5) five years after the date of purchase, provided that it is at all times operated in accordance with specifications and not subject to freezing.

Commercial One Year Warranty on Resin

US Water Systems will provide a replacement resin to any original equipment purchaser in possession of the US Water Commercial water softener that fails for (1) one years after the date of purchase, provided that it is at all times operated in accordance with specifications and not subject to freezing. Warranty may not be honored on systems used to remove iron, manganese or with very high chlorine concentrated feed waters should have additional equipment to protect the softener.

Residential Lifetime Warranty on Resin

US Water Systems will provide a replacement resin to any original equipment purchaser in possession of the US Water Synergy water softener that fails for the lifetime after the date of purchase, provided that it is at all times operated in accordance with specifications and not subject to freezing. Warranty may not be honored on systems used to remove iron, manganese or with very high chlorine concentrated feed waters should have additional equipment to protect the softener.

General Provisions

US Water Systems assumes no responsibility for consequential damage, labor or expense incurred as a result of a defect or for failure to meet the terms of these guarantees because of circumstances beyond our control. Installation workmanship failure is not covered under warranty. Damage caused by environmental conditions such as, lightening strikes, humidity or heat will not be covered under warranty.

These warranties are in lieu of all other warranties expressed or implied, and we do not authorize any person to assume for us any other obligation on the sale of this water conditioner. No responsibility is assumed for delays or failure to meet these warranties caused by strike, government regulations or other circumstances beyond the control of *US WATER SYSTEMS, INC.*

TO OBTAIN WARRANTY SERVICE, CALL OR WRITE: *US WATER SYSTEMS, INC. 1209 COUNTRY CLUB ROAD INDIANAPOLIS, IN 46234 (317) 271-8600.* ANY IMPLIED WARRANTIES OF FITNESS OR MERCHANTABILITY ARE LIMITED TO THE TERMS OF THIS EXPRESSED WARRANTY AND THERE ARE NO WARRANTIES WHICH EXTEND BEYOND THOSE HEREIN. *US WATER* SHALL NOT BE LIABLE FOR ANY INCIDENTAL OR CONSEQUENTIAL DAMAGES.

SOME STATES DO NOT ALLOW THE EXCLUSION OR LIMITATIONS OF INCIDENTAL OR CONSEQUENTIAL DAMAGES SO THE ABOVE LIMITATION MAY NOT APPLY TO YOU. THIS WARRANTY GIVES YOU SPECIFIC LEGAL RIGHTS, AND YOU MAY ALSO HAVE OTHER RIGHTS WHICH VARY FROM STATE TO STATE.

THIS WARRANTY MAY BE TRANSFERRED TO A SUBSEQUENT OWNER WITH WRITTEN APPROVAL OF *US WATER* AND PAYMENT OF STANDARD TRANSFER FEE.

Synergy is a product of US Water Systems.

