

SOFTENER

MODEL NO. 140-28-150-S-4M

CAPACITY:

MIN. 120,000 grs. @ 10 lbs./cu.ft.
 MAX. 150,000 grs. @ 15 lbs./cu.ft.

FLOW RATE:

NORMAL 25 gpm
 PEAK 53 gpm
 BACKWASH 10 gpm

TANK SIZE: 18" x 65"

COMPOSITE

MEDIA:

RESIN 5 cu.ft.
 GRAVEL 100 lbs.

PIPE SIZE:

INLET 1-1/2"
 OUTLET 1-1/2"
 DRAIN 1"
 BRINE 1/2"
 METER 1-1/2"

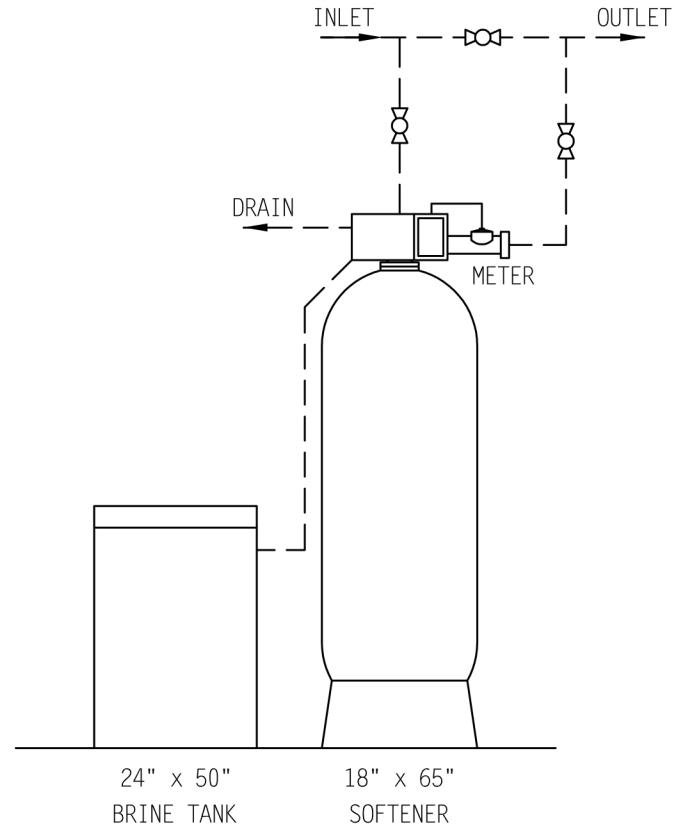

BRINE TANK

TANK SIZE: 24" x 50"

POLYETHYLENE

CAPACITY:

100 gals.
 900 lbs./salt

BRINE VALVE: 454HF

BRINE WELL: 5"

WEIGHT (APPROX)

TOTAL SHIPPING 558 lbs.
 TOTAL OPERATING 1,545 lbs.

SPACE REQUIRED (APPROX)

46"L x 24"W x 78"H

NOTE:

ALL DASHED PIPE, VALVES,
 AND FITTINGS NOT PROVIDED
 BY US WATER SYSTEMS

PEAK FLOWS ARE NOT
 RECOMMENDED FOR EXTENDED
 PERIODS OF TIME.

DO NOT SCALE DRAWING

THIS DRAWING IS ISSUED IN CONFIDENCE AND
 CANNOT BE REPRODUCED OR USED TO
 MANUFACTURE ANYTHING SHOWN OR REFERRED
 TO WITHOUT DIRECT WRITTEN PERMISSION FROM
 US WATER SYSTEMS

		US WATER SYSTEMS 1209 COUNTRY CLUB RD INDIANAPOLIS, IN 46234 1-800-608-8792	
		GENERAL ARRANGEMENT DWG. SOFTENER 150K SYSTEM 4-METER	
DRAWN BY: M. CURTIS	DATE:		DWG. NO. 140-28-150-S-4M
CHECKED BY:	DATE:		
PAGE 1 OF 1	DATE:		