

LAWN STAKE ASSEMBLY & INSTALLATION INSTRUCTIONS

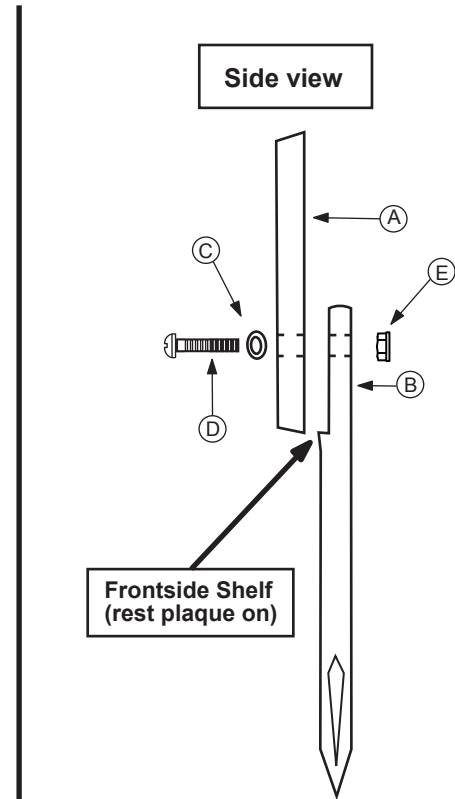
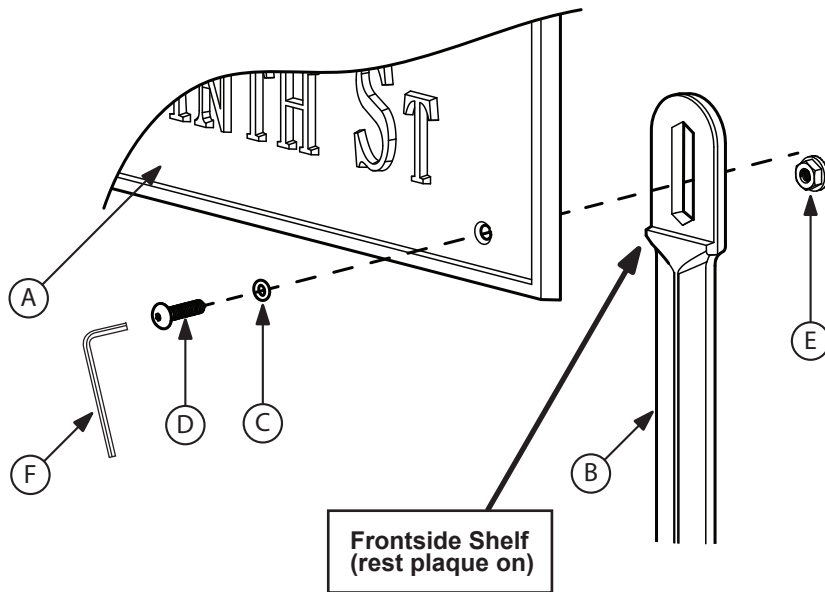

PARTS:

- (A) Plaque - 1
- (B) Lawn Stakes - 1 or 2
- (C) Screw Gaskets - 2
- (D) Hex Drive Cap Screws - 2
- (E) Flanged Hex Nut - 2
- (F) Allen Wrench - 1

TO ASSEMBLE:

- 1) Push an O-Ring Gasket (C) onto the threads of the Cap Screw (D) until it reaches the head of the screw.
- 2) Position stake (B) on the back side of plaque (A) so that the bottom of the plaque is resting on the stake's frontside shelf.
- 3) From the backside of the Stake (B), place the Flanged Hex Nut (E) into the slot at the top. **Note:** The hex portion of the hex nut should be inside of the stake.
- 4) While holding the lawn stake (B) and Hex Nut (E) in place, insert a Cap Screw (D) through the hole in the plaque and thread it into the Hex Nut.
- 5) Being sure the bottom of the plaque is resting tight against the stake's front shelf and that the stake is perpendicular to the bottom of the plaque, use the allen wrench (F) to tighten the Cap Screw (D).
- 6) If your Plaque requires a second stake, Repeat steps 1-5.

TO INSTALL:

IMPORTANT NOTE! Plaque and Stake WERE NOT designed to be driven into the ground. Please follow installation steps below for optimum results.

- 1) Dig holes 6" to 8" deep and place lawn plaque stakes into the holes.
- 2) Check plaque for vertical and level.
- 3) Back fill holes and pack soil firmly down against the stakes.

CLEANING INSTRUCTIONS:

Whitehall Plaques are made of hand-cast aluminum with tough finishes to withstand exposure to the elements. To clean your plaque, use a non-abrasive detergent and water with a cloth, sponge, or soft brush. **Note:** The simulated weathered bronze cannot be brightened by polishing- This hand-painted finish should retain its finish for many years without special attention.