



Professional Mixing Controller

PMC 06ProA

OWNER'S MANUAL

VESTAX CORP.

2-37-1 Kamiyama, Setagaya-ku, Tokyo 154-0011

Phone: 03-3412-7011 Fax: 03-3412-7013

VESTAX MUSICAL ELECTRONICS CORP.

2860 Cordelia Rd. Suite 120 Fairfield, CA 94585 U.S.A.

Phone: 707-427-1920 Fax: 707-427-2023

VESTAX (Europe) Ltd.

18 St. Christopher's Road, Haslemere, Surrey GU27 1DQ England

Phone: (0) 1428-653117 Fax: (0) 1428-661021

CONGRATULATIONS!

Thank you for purchasing VESTAX PMC-06ProA Mixtick, Professional Mixing Controller. Please read this owner's manual carefully before you start to use your mixer, so that you will fully understand all of the special features and enjoy the full use of the product.

FEATURES

- THE PMC-06ProA is just size for DJ turntables.
- This mixer is provided the "REVERSE" switch which can change "PGM 1" sound for "PGM 2" sound of a crossfader in a moment.
- A superior grade crossfader is fitted to PMC-06proA enabling super smooth operation together with long life. Another first from VESTAX is PHOTO COUPLER operation of the crossfader. This allows Crossfade Curve adjustment. Now different styles of mixing, from long running mixes, to scratching and cutting can all be catered for by simple adjustment to the crossfade, even whilst "in the mix".
- A "Selectable Position" input Transformer switch is also fitted. It is possible to fit the switch in any of EIGHT positions, to suit the style or preference of the DJ.
- A total of 4 inputs (2 Phono, 2 Line) are equipped with a 2 band equalizer (Hi and Lo) and L-R balanced volume.
- The same method of construction as the most expensive studio mixers is employed. Vertical PCB's behind the faders allow the most stringent of design criteria to be met.

SPECIFICATIONS

- Nominal Input Level/Impedance
 - LINE -10dBv/10k Ω
 - PHONO -42dBv/56k Ω
- Nominal Output Level/Impedance
 - LINE -7dBm/2k Ω
 - PHONES 90mW max. @ 47 Ω / \geq 8 Ω
- Frequency Response 20Hz-10kHz \pm 1.5dB
- Cross talk \geq 100dB
- SN Ratio \geq 80dB
- THD < 0.01%
- Dimensions (W×H×D) 107×392×160mm
- Weight 2.5kg

IMPORTANT

To prevent electric shock, do not remove cover. No user serviceable parts inside. Refer servicing to qualified personnel. Always disconnect all equipment from the main supply when disconnecting/reconnecting signal leads. The power cord should be connected last. Make sure that the power switch is off when connecting. Disconnect from AC supply when equipment is not used for extended time.

WARRANTY

Warranty might vary from country to country. Each distributor has their own warranty system in accordance with country or state regulations or laws. VESTAX observes the manufacturing country's regulations.

PRECAUTIONS

- *Humidity and dust
Avoid use where there is high humidity and dust which may cause damage to internal parts.
- *Temperature
Avoid use in hot, (over 35 $^{\circ}$ C) and cold, (below 5 $^{\circ}$ C) locations. Keep the unit away from extreme direct heat such as direct sunlight, heating radiators, or closed vehicles.
- *Power cord handling
Connecting the power cord to other cords or joining cords together can cause fire and electric shock. This is extremely dangerous.
Take precaution when handling AC plugs and connectors. Handle only the plug or connector and do not perform these operations with wet hands.
- *Keep away from liquids
Do not stand vessel containing liquids on or near the equipment. If liquid enters equipment, disconnect the power cord from the power outlet immediately.

CONTROL AND FUNCTIONS

TOP PANEL

- ① **TRIM (PGM1, PGM2)**
Adjust the input level of each channel. Set INPUT FADER to 7-8 position, adjust TRIM so that INPUT LEVEL METER shows about 0 dB.
- ② **PGM EQs (PGM1, PGM2)**
Adjust the HI and LO frequencies for each PGM channel.
- ③ **INPUT BALANCE (PGM1, PGM2)**
Adjust the stereo balance for each PGM channel. Can be used for adjusting the unbalanced stereo image caused by strong Anti-Skating setting. Clockwise rotation from center position increases volume of R over L channel. Counter clockwise rotation increases volume of L channel over R.
- ④ **INPUT LEVEL METER**
The LED level meters indicate the signal level of each PGM channel.
- ⑤ **INPUT SELECTOR (PGM1, PGM2)**
Used to select the input (LINE or PHONO) to be sent to each PGM channel. Vertical position is for PHONO input. It can also be used for TRANSFORMER SCRATCH. Its operational direction is selectable. you can change the direction by removing the top panel.

How to change direction:

- Remove each fader knob and four screws (*) which fix the top panel.
- Remove the top panel.
- Remove the screws on switch panel (**) and change the direction. Then re-fix it with the screws.

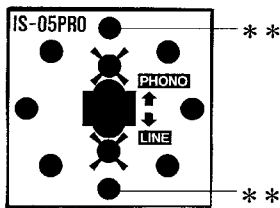

- Place the top panel and fix it with four screws. Then replace each fader knob.

※ When you change any parts, do not loose the screw of ✕ marks.

- ⑥ **INPUT FADER (PGM1, PGM2)**
Used to adjust input level of each PGM channel. Input fader curve can be changed with a switch located on the INPUT FADER unit. This is a detachable fader for ease of replacement. Replace with IF-05PRO when it is worn out. Please see CROSS FADER section for how to replace it.

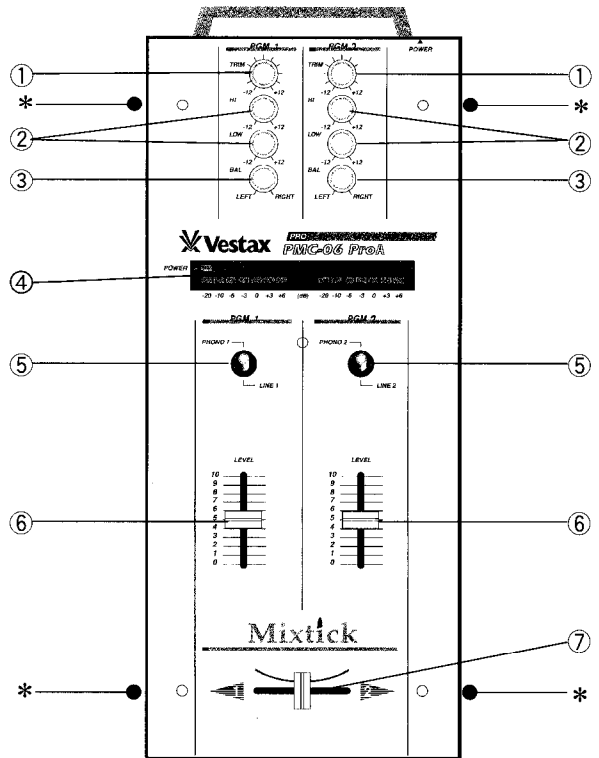

How to change fader curve:

- Remove the top panel as for changing INPUT SELECTOR direction.
- Remove two screws which hold the INPUT FADER unit.
- Take the unit out.

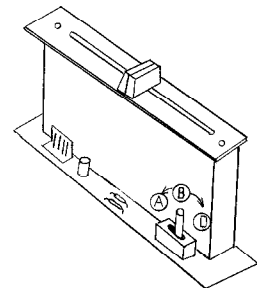

- Select the curve from three kinds with the switch on the unit.
- Replace the fader unit and fix it with screws.
- Replace the top panel and fix it with four screws. Then replace each fader knob.

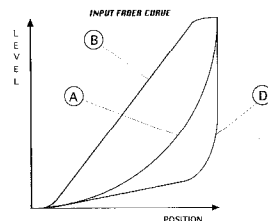

⑦ CROSS FADER

Mix the signals of PGM1 and PGM2. When the crossfader is set in the center position, both PGM1 and PGM2 can be heard. This is a detachable fader for ease of replacement with CF-05PRO when it is worn out.

How to replace the fader:

- Remove the top panel as for changing INPUT SELECTOR direction.
- Remove two screws which hold the fader unit.
- Take the unit out.

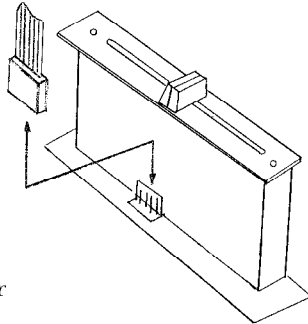

- Carefully remove the multi-cable connector from fader unit.

FRONT PANEL

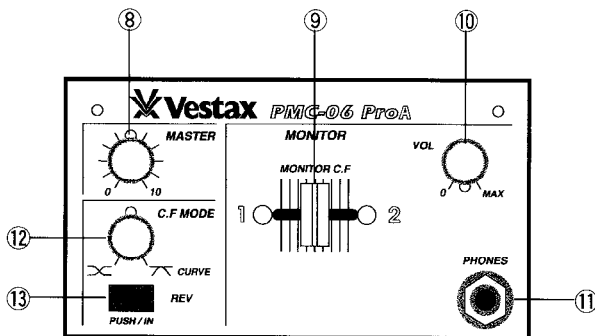

⑧ MASTER LEVEL CONTROL

Adjust the LINE output level.

⑨ C. F. MONITOR

Select PGM for monitoring as same operation as the crossfader. This signal for monitoring comes from pre-fader. It allows you to hear the input signal without sending to LINE OUT.

⑩ HEADPHONES VOLUME

Adjust the headphones output level.

⑪ HEADPHONES JACK

When listening with stereo headphones, connect them to this jack. This features crossfaded stereo cue system.

⑫ CROSS FADER MODE

Adjust the crossfader curve. Clockwise rotation gives a steep crossfade good for scratching and cutting. Counter clockwise rotation gives a gentle crossfade good for long running mixes.

⑬ CROSS FADER REVERSE SWITCH

Usually, as cross fader is moved the left, PGM 1 sounds are out. But as this switch is turned on, output sounds are changed PGM 2 sounds for PGM 1 sounds in a moment. So as a crossfader is moved the left, PGM 2 sounds is out.

- Insert the connector to the new fader unit.
- Replace the fader unit and fix it with screws.
- Replace the top panel and fix it with four screws. Then replace each fader knob.

REAR PANEL

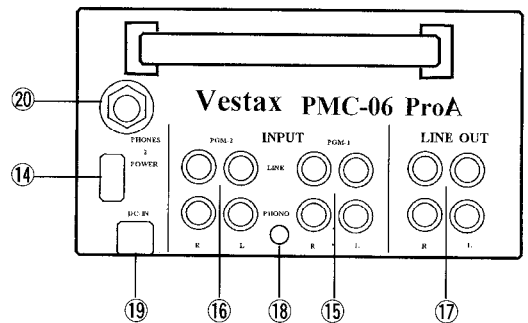

⑭ POWER SWITCH

LED located on front panel is lit when on.

⑮ INPUT JACK 1

They are used for PGM1 input. Connect turntable equipped with MM pickup cartridge to PHONO input. CD player or tape deck are for LINE input. Line level musical instruments with stereo outputs such as rhythm machine or sampler are also good for LINE.

⑯ INPUT JACK 2

They are used for PGM2 input. And work the same as INPUT JACK 1.

Note: Levels are set for MM type phono cartridge. If MC type phono cartridge is used, a pre-amp is required.

⑰ LINE OUT

Connect to the input of power amplifier. This mixer has two pairs of LINE OUT and same signal outputs from both of OUTPUTs. This means that LINE OUT can be used for main output and sub.

⑱ GROUND TERMINAL

Connect ground lead of the turntable. This helps to reduce noise and hum.

⑲ DC IN

Connect AC adaptor supplied with this unit.

⑳ HEADPHONES JACK

When listening with stereo headphones, connect them to this jack. This features crossfaded stereo cue system.