



Professional Mixing Controller

# *PMC-05 Pro SL* **VCA**

**OWNER'S MANUAL**

**Vestax Corporation**

1-18-6 Wakabayashi, Setagaya-ku, Tokyo 154-0023 Japan  
Phone 03-3412-7011 Fax 03-3412-7013  
Web : [www.vestax.com](http://www.vestax.com)

**Vestax (Europe) Ltd.**

Unit 5 Riverwey Industrial Park Alton Hampshire GU34 2QL England, U.K.  
Phone (0)1420-83000 Fax (0)1420-80040  
Web : [www.vestax.co.uk](http://www.vestax.co.uk)

**Vestax Europe Technical Support**



Rheinstr.213 D-53332 Bornheim Germany  
Phone 49(0)2222-95-23-72 Fax 49(0)2222-95-23-74

# CONGRATULATIONS !

Thank you for purchasing the Vestax PMC05ProSLVCA Mixing Controller. We suggest that you read through this owner's manual thoroughly so that you may enjoy the full use of this product safely and in the knowledge of all its special features and suitable applications.

## CONTENTS

C A U T I O N .....	2
IMPORTANT SAFEGUARDS .....	3
F E A T U R E S .....	4
F U N C T I O N S .....	5
TOP PANEL SECTION .....	5
SAMPLER/DELAY SECTION .....	7
FRONT PANEL SECTION .....	8
REAR PANEL SECTION .....	9
HOW TO USE THE SAMPLER/DELAY .....	10
HOW TO CHANGE THE FADER UNIT .....	13
HOW TO CHANGE INPUT SELECT SWITCH .....	14
C O N N E C T I O N .....	15
S P E C I F I C A T I O N .....	15

	<b>CAUTION</b> RISK OF ELECTRIC SHOCK DO NOT OPEN	
<p>CAUTION : TO REDUCE THE RISK OF ELECTRIC SHOCK DO NOT REMOVE COVER ( OR BACK ) NO USER-SERVICEABLE PARTS INSIDE REFER SERVICING TO QUALIFIED SERVICE PERSONNEL</p>		



The lightning flash with arrowhead symbol , within an equilateral triangle , is intended to alert the user to the presence of uninsulated " dangerous voltage " within the product's enclosure that may be of sufficient magnitude to constitute a risk of electric shock to persons .



The exclamation point within an equilateral triangle is intended to alert the user to the presence of important operating and maintenance ( servicing ) instructions in the literature accompanying the appliance .

**TO REDUCE THE RISK OF FIRE OR ELECTRIC SHOCK , DO NOT EXPOSE THIS APPLIANCE TO RAIN OR MOISTURE .**

# IMPORTANT SAFEGUARDS

## READ BEFORE OPERATING EQUIPMENT

This product was designed and manufactured to meet strict quality and safety standards. There are, however, some installation and operation precautions which you should be particularly aware of.

1. Read instructions-All the safety and operating instructions should be read before the appliance is operated.
2. Retain instructions-The safety and operating instructions should be retained for future reference.
3. Heed Warnings-All warnings on the appliance and in the operating instructions should be adhered to.
4. Follow Instructions-All operating and use instructions should be followed.
5. Cleaning-Do not use liquid cleaners or aerosol cleaners. Use a damp cloth for cleaning.
6. Attachments-Do not use attachments not recommended by the product manufacturer as they may cause hazards.
7. Water and Moisture-Do not use this product near water-for example, near a bath tub, wash bowl, kitchen sink, or laundry tub, in a wet basement, or near a swimming pool, and the like.
8. Accessories-Do not place this product on an unstable cart, stand, tripod, or table. The product may fall, causing serious injury to a child or adult, and serious damage to the appliance. Use only with a cart, stand, tripod, bracket, or table recommended by the manufacturer, or sold with product. Any mounting of the appliance should follow the manufacturer's instructions, and should use a mounting accessory recommended by the manufacturer.
9. This product should never be placed near or over a radiator or heat register. This product should not be placed in a built-in installation such as a bookcase or rack unless proper ventilation is provided or the manufacturer's instructions have been adhered to.
10. Power sources-This product should be operated only from the type of power source indicated on the marking label. If you are not sure of the type of power supply to your home, consult your appliance dealer or local power company.
11. Lightning-For added protection of this product during a lightning storm, or when it is left unattended and unused for long periods of time, unplug it from the wall outlet. This will prevent damage to the product due to lightning and power-line surges.
12. Overloading-Do not overload wall outlets and extension cords as this can result in a risk of fire or electric shock.
13. Object and Liquid Entry-Never push objects of any kind into this product through openings as they may touch dangerous voltage points or short-out parts that could result in a fire or electric shock. Never spill liquid of any kind on the product.
14. Servicing-Do not attempt to service product yourself as opening or removing covers may expose you to dangerous voltage or other hazards. Refer all servicing to qualified personnel.

15. Damage Requiring Service- Unplug this product from the wall outlet and refer servicing to qualified service personnel under the following conditions:

- a. When the power-supply cord or plug is damaged.
- b. If liquid has been spilled or objects have fallen into the product.
- c. If the product has been exposed to rain or water.
- d. If the product does not operate normally by following the operating instructions. Adjust only those controls that are covered by the operating instructions as an improper adjustment of other controls may result in damage and will often require extensive work by a qualified technician to restore the product to its normal operation.
- e. If the product has been dropped or cabinet has been damaged.
- f. When the product exhibits a distinct change in performance this indicates need for service.

16. Replacement Parts- When replacement parts are required, be sure the service technician has used replacement parts specified by the manufacturer or have the same characteristics as the original parts. Unauthorized substitutions may result in fire, electric shock or other hazards.

17. Safety Check- Upon completion of any service or repairs to product, ask the service technician to perform safety checks to determine that the product is in proper operating condition.

18. Carts and Stands- The appliance should be used only with a cart stand that is recommended by manufacturer.

19. An appliance and cart combination should be moved with care. Quick stops, excessive force, and uneven surfaces may cause the appliance and cart combination to overturn.



## FEATURES

This machine includes SAMPLER and a DELAY function .

You can use delay sounds or sampling loop by pushing the EFFECT switch on the each PGM input channel and MIC input channel without connecting other effectors.

You can use over-dubbing for the sampler function.

It is possible to record other phrases in piles in the phrase which sample recording was carried out.

Therefore, the possibility of DJ plays on the stage grows further.

Moreover, it is also convenient for DJ play or practice of scratch.

By introducing double panel structure, the attachment screw of the fader circumference on the front panel causing trouble in the case of scratch performance and the slot on the panel were eliminated.

The fader location reflecting professional DJ's opinion realizes high performance.

The VCA system is adopted as the crossfader section which serves as an important point in the case of scratch performance.

Since this system does not go through a sound signal in the crossfader itself, it realizes a long-life and high-quality sound.

The input select switch can be set up in the operation direction (vertical, horizontal, slant)

Each input is equipped with the equalizer of two bands of HI and LOW.

Fine compensation for tone quality is possible.

CF reverse switch is enable to exchange the side PGM1 to PGM2 quickly.

The curve property of a crossfader can be changed by the volume on a top panel.

Moreover, you can change a curve property into three steps by the switch on a fader unit.

PMC-05pro3 has a select switch for headphone monitor.

It is possible to monitor the signal inputted and the signal outputted by changing each other.

Since you can monitor master output with lowered MASTER LEVEL volume, it is convenient to practice even at night.

# FUNCTIONS

## TOP PANEL SECTION

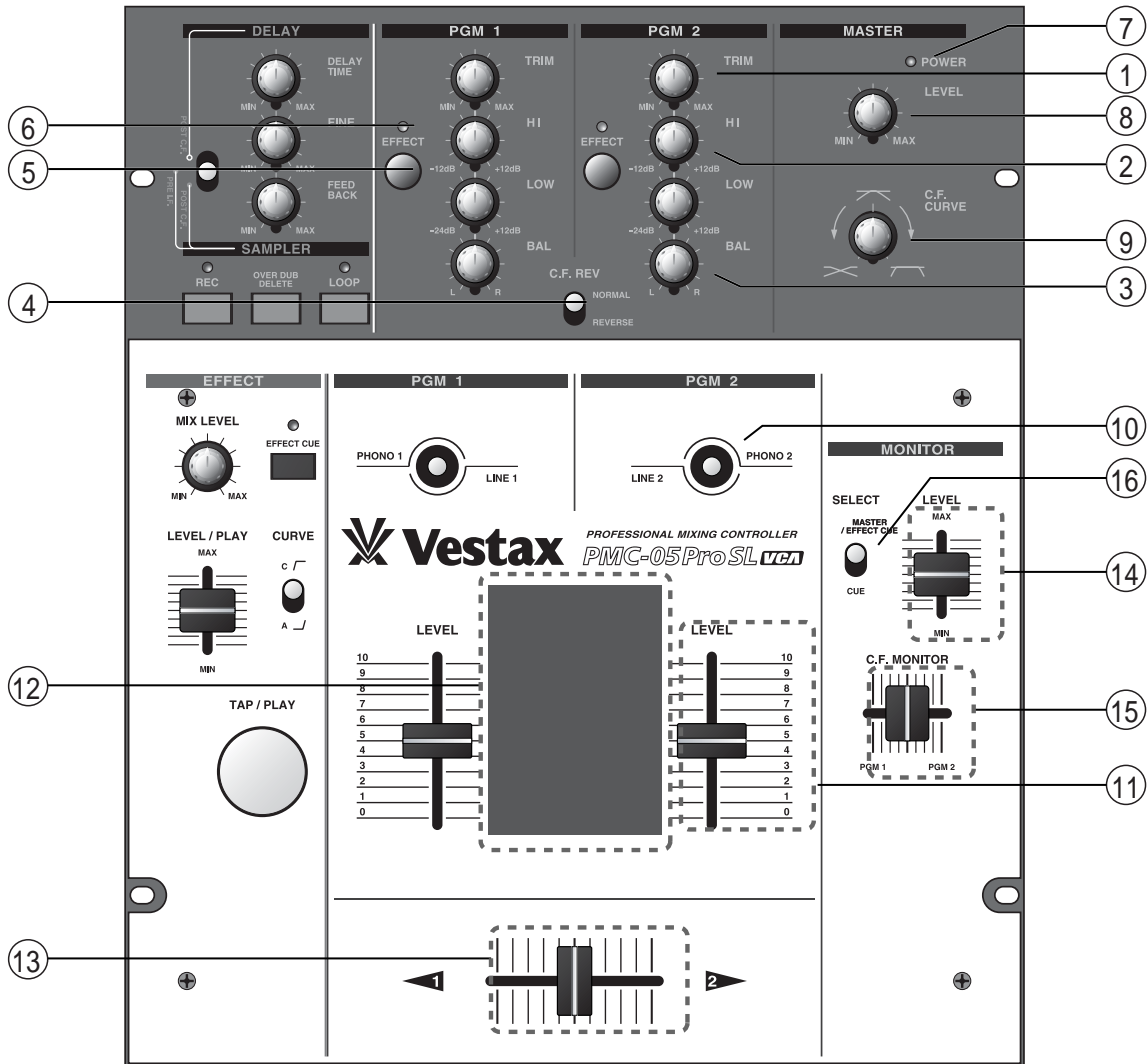

① **TRIM (PGM1/PGM2)**

This pot adjusts the input level of each PGM channel. For optional acoustic quality, set the INPUT FADER to a position of 7 or 8 then; adjust the TRIM so that a sufficient signal is fed through the channel without distortion.

② **PGM EQ (PGM1/PGM2)**

This pot adjusts the HI and LOW frequencies for each PGM channel.

③ **PGM BALANCE (PGM1/PGM2)**

This pot adjusts the stereo balance level for each PGM Channel. Can also be used to adjust an unbalanced stereo image. From a center position a clockwise rotation will increase the volume of channel R over L. Whereas, a counter clockwise rotation will increase the volume of channel L over R.

④ **CROSSFADER REVERSE SWITCH**

This switch reverses the action of the crossfader by switching PGM1 and 2.

⑤ **PGM EFFECT (program effect) SWITCH**

It is the switch which sends the signal of each PGM channel to built-in sampler / delay. If it is pushed, a signal will be sent to sampler / delay section, and PGM EFFECT indicator will light up.

⑥ **PGM EFFECT INDICATOR**

The light will be switched on if PGM EFFECT SWITCH of each PGM channel is pushed.

⑦ **POWER INDICATOR**

It is the indicator which tells power is supplied. Please confirm that this indicator is ON before use.

⑧ **MASTER LEVEL**

It is the volume which adjusts the level of the signal outputted from OUTPUT JACK of a rear panel.

⑨ **CF CURVE VOLUME**

It is the volume which sets up the curve property of a C.F.CURVE (crossfader curve).

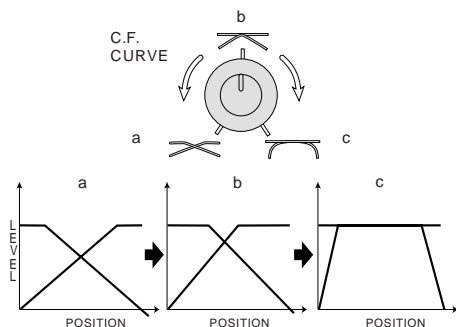

(a) Curve for a long mix

If CROSSFADER volume is moved, the volume level changes gently with PGM-1 and PGM-2 signal interchanging each other.

(b) It is the middle curve of (a) and (c)

(c) Curve for scratch performance

The volume of CROSSFADER rise up most rapidly.

⑩ **INPUT SELECT SWITCH**

This switch is used to select the input (LINE or PHONO) to be sent to each PGM channel. The upper most position will select PHONO input. This selector switch can also be used to perform for TRANSFORMER SCRATCH. The operation direction of this switch is selectable. To change the operational direction of this switch remove, the top panel and make the necessary the top panel.

⑪ **INPUT FADER (PGM1/PGM2)**

This fader is used to adjust the input level of each PGM channel. The input fader curve can be changed using a switch located on the unit itself. This fader is a detachable for making easy replacement. Ensure that you replace with

an IF-05PCV when it will worn out. For more comprehensive instructions please refer to the "HOW TO CHANGE THE FADER UNIT" section of this user guide.

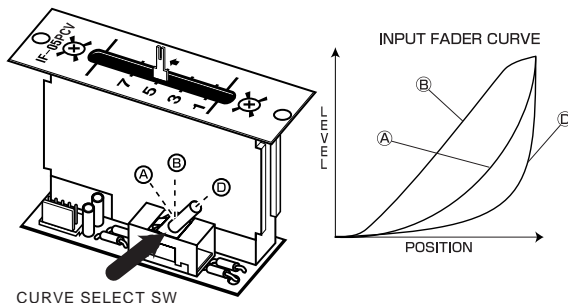

⑫ **INPUT LEVEL METER**

The LED level meters indicate the signal level of each PGM channel.

⑬ **CROSSFADER**

When the input level of PGM1 and PGM2 are properly set, PGM1 will be heard with the crossfader set to the left side. PGM2 will be heard with the cross fader set to the right side. When the crossfader is set in the center, both programs will be heard. This is detachable fader for the easy replacement with "CF-PCV" when it is worn out. It is the switch which chooses the signal (PHONO and LINE) inputted into each PGM channel.

⑭ **MONITOR LEVEL**

It is the fader which adjusts the volume of the headphone connected to PHONES jack.

⑮ **C.F.MONITOR FADER**

It is the fader which chooses the signal monitored by headphone. Depends on the position of a knob, the signal balance of PGM-1 and PGM-2 changes like CROSSFADER.

**Notes**

Even if C.F.REVERSE switch is set to the "REVERSE" side, C.F.MONITOR volume is not REVERSE(ed).

⑯ **MONITOR SELECT SWITCH**

It is the switch which changes the monitor form of headphone.

**MASTER/EFFECT CUE** When a EFFECT CUE switch is OFF, it can act as the monitor of the signal outputted from LINE OUT jack .Moreover, when a EFFECT CUE switch is ON, it can act as the monitor only for of the signal outputted from built-in sampler / delay.

**CUE** It can act as the monitor of the signal of PGM-1 or PGM-2 chosen by C.F.MONITOR fader. When C.F MONITOR fader is set up in the center position, you can monitor the signal of both PGM-1 and PGM-2.

## SAMPLER/DELAY SECTION

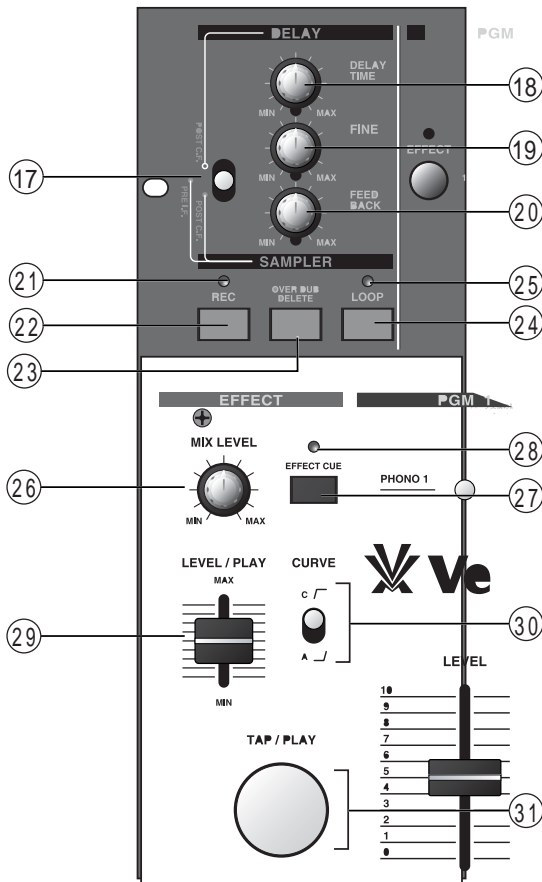

**17 SAMPLER/DELAY SELECT SWITCH**  
 This switch selects the effector function to either sampler or delay.  
 Moreover, in the sampler side, either Pre I.F. (before a inputfader) or Post C.F. (after a crossfader) can be chosen which signal is effected with the same switch.

**18 DELAY TIME**  
 It is the volume which sets up delay time roughly (0.5msec - 1450msec).  
 TAP/PLAY switch can also set up the delay time.  
 The priority is given to the direction operated at latest.

**Notes**

When SAMPLER/DELAY SELECT switch is set up to other than DELAY mode, it dose not work.

**19 FINE**  
 It is the volume which sets up delay time finely (0msec - 90msec).

**Notes**

When SAMPLER/DELAY SELECT switch is set up to other than DELAY mode, it dose not work.

**20 FEEDBACK**  
 It is the volume which adjusts the amount of feedbacks (time of repeat). The number of times becomes 1 time when the pot turned to the left, and the number of times increases when the pot turns to the right.

**Notes**

When SAMPLER/DELAY SELECT switch is set up to other than DELAY mode, it dose not work.

**21 REC SWITCH**  
 It is the switch which operates stop and start of recording. REC indicator lights up during recording. Over dubbing will be started when this REC switch is pushed during LOOP playback. The maximum recording time is 23.8 seconds. If it records 11.9 seconds and more, you can not use overdubbing function. If 11.9 seconds and 23.8 seconds are approached, an indicator will blink.

**Notes**

When SAMPLER/DELAY SELECT SWITCH is set up to other than SAMPLER mode, it dose not work.

**22 REC INDICATOR**  
 It is the indicator which tells a recording operation. If recording time passes over 8.9 seconds, it will warn with indicator starting blink and tells approaching marginal time (11.9 seconds) of over dubbing. Moreover, if it passes over 20.8 seconds , it will warn with indicator starting blink again of approaching 23.8 seconds of the longest recording time.

**23 OVERDUB DELETE SW**  
 It is the switch which deletes the phrase of overdubbing. If this OVERDUB DELETE switch is pushed during LOOP playback, it will leave only the phrase recorded first and the phrase of overdubbing will be deleted.

**24 LOOP SWITCH**  
 It is the switch which operates LOOP mode. If a switch is pushed, it will be set as loop playback mode and LOOP indicator will light up.If this LOOP switch is pushed during loop playback, loop playback stops and it will be in a loop playback standby.(Loop playback mode is not canceled at this time.) If this LOOP switch is pushed during loop playback standby, loop playback mode will be canceled.

**25 LOOP INDICATOR**  
 It is the indicator which tells ON/OFF in loop playback mode. When loop playback mode is ON, an indicator lights up.



**26 MIX VOLUME**

It is the volume which adjusts the master output level of SAMPLER / DELAY. When you want to monitor the signal outputted from SAMPLER / DELAY by headphone, please set this volume minimum.

**27 EFFECT CUE SWITCH**

It is the switch for monitor sound of SAMPLER / DELAY by headphone. When the switch is pushed, MONITOR SELECT switch is changed to a MASTER/EFFECT CUE sides, you can monitor of the signal outputted from SAMPLER / DELAY. When a switch is on, EFFECT CUE indicator lights up.

**28 EFFECT CUE INDICATOR**

It is the indicator which tells ON/OFF state of EFFECT CUE switch. The light is up when a EFFECT CUE switch is on.

**29 LEVEL/PLAY VOLUME**

It is the volume which adjusts the effect level of SAMPLER / DELAY. In the SAMPLER mode, the fader operates start/stop of a phrase of sampling. If volume is raised, it will start playback with the level according to the scale of the volume, and if it is set at minimum, playback will stop.

**30 CURVE SWITCH**

It is the switch which sets up the volume curve property of LEVEL/PLAY volume. At the time of the "C" side, level of sound increase rapidly. And at the "A" side, the level increase loosely. It is convenient if you use properly in the right time of DELAY mode and SAMPLER mode.

**31 TAP SWITCH**

In the DELAY mode, switch works to set up delay time. And the button blinks according to the set-up delay time. In the SAMPLER mode, it works as a switch for starting. During playback, the button lights up.

**FRONT PANEL SECTION****32 MIC input jack**

It is the input jack for MIC.

**33 MIC EFFECT SWITCH**

It is the select switch which sends the signal of a MIC channel to built-in SAMPLER/ DELAY. If it pushed, a signal will be sent to SAMPLER / DELAY, and MIC EFFECT SEND indicator will light up.

**34 MIC EFFECT INDICATOR**

LED will light up when MIC EFFECT switch is pushed.

**35 MIC LEVEL VOLUME**

It is the volume which adjusts the level of the microphone connected to MIC input jack.

**36 PHONES (headphone) jack**

It is a jack only for headphone. Please use the stereo headphone over impedance 8ohms.

## REAR PANEL SECTION



### 37 FOOT SWITCH JACK

It is the jack for a foot switch. The foot pedal works as a REC switch on the front panel. When you want to record scratch play without hands, it is convenient. Please use the foot pedal to make up (short) when pushed.

### 38 LINE INPUT JACK

It is a jack for CD player, CD-R / RW player, MD player, the TAPE deck, DAT and VTR, and a DVD player. The RCA pin plug (unbalanced input) is supported.

### 39 PHONO INPUT JACK

It is a jack for a turntable. Please connect the turntable to which MM cartridge was set. In addition, in use of a MC type cartridge, optional head amplifier is needed.

### 40 MASTER OUT JACK

It is a jack for amplifier, master console, etc. (In the case of the amplifier for audios, please connect with an input jack with the notation of LINE or AUX.)

### 41 GND TERMINAL

It is the terminal that connects the earth wire of a turntable. In order to decrease a noise and a hum, please be sure to connect when you use a turntable.

### 42 POWER JACK

It is the jack that connects a power supply adapter. Please connect the original adapter (AC-14).

### 43 POWER SWITCH

It is on/off-switch of a power supply. When a power supply switch is on, POWER indicator lights up on the front panel.

### Notes

In case you operate this switch, please make sure to lower volumes, of connected power amplifier, or the power is turned off.

Keep in mind that there is a possibility of it not only having a bad influence on power amplifier on a speaker, but also a noise entering, and damaging itself in case a power supply is turned on.

# HOW TO USE THE SAMPLER/DELAY

## Delay

Please check before operation that sound has come out from a MIXER or the connected speaker.

SA  
NOR

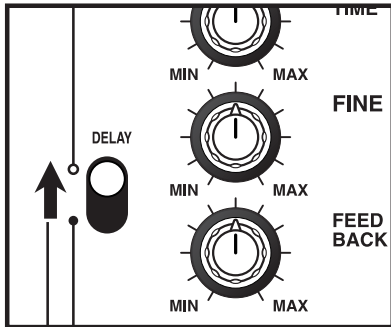

### 1. Set it as DELAY mode

SAMPLER/DELAY SELECT switch is set to a "DELAY" side.

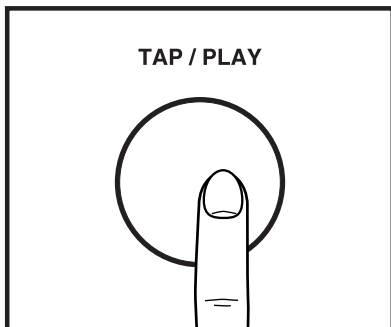

### 2. Set up delay time

Strike TAP switch several times, listening to music source if you want to set delay by the speaker or headphone. (At this time, the button blinks according to the tempo that the button struck.)

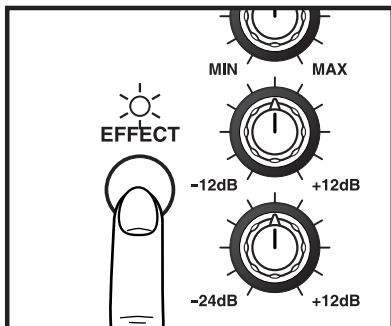

### 3. Choose the channel to which an effect is applied

It checks that pushed PGM EFFECT switch of the channel (PGM-1 or 2) you want to effect, and check PGM EFFECT indicator is lights up and listen to the effect sound by pushing EFFECT CUE SWITCH.

(caution: If the LEVEL/PLAY VOLUME is minimum, you can't monitor effect sound. Please set LEVEL/PLAY VOLUME to suitable level.)

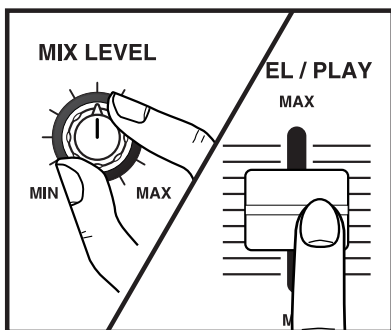

### 4. Apply the effect.

An original sound (sound which had come out of the speaker from the first), and add the effect sound by raising MIX volume and LEVEL/PLAY volume. At this time, if CURVE switch is set to the "A" side, effect sound can be mixed gradually.

## SAMPLER

### NORMAL RECORDING

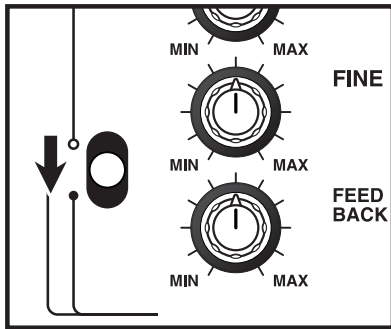

#### 1. Set it as SAMPLER mode.

SAMPLER/DELAY SELECT switch is set to a "PRE-I.F" or "PRE-C.F" side. You can record the signal passed before inputfader on PRE-I.F, and the signal passed before crossfader on PRE C.F.

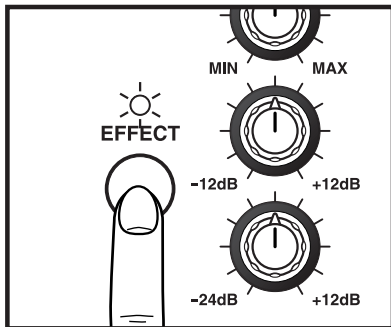

#### 2. Select the channel to record

Please push PGM EFFECT switch of the channel (PGM-1 or 2) you want to record. And check PGM EFFECT indicator lights up.

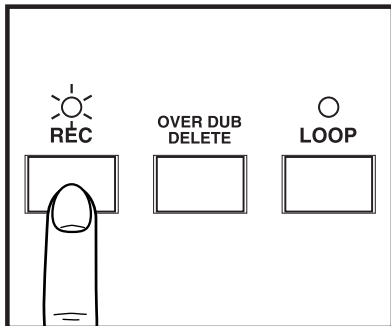

#### 3. Record

REC switch is pushed hearing the output sound from headphone or a speaker, and recording is started. Recording will be stopped if a REC switch is pushed again. (Keep in mind that you can't use overdubbing function when you record over 11.9 seconds.) REC INDICATOR blinks when the limit of overdubbing is coming. If you continue the recordings over the limit of overdubbing, indicator blinks again when the limit of recording time is coming.

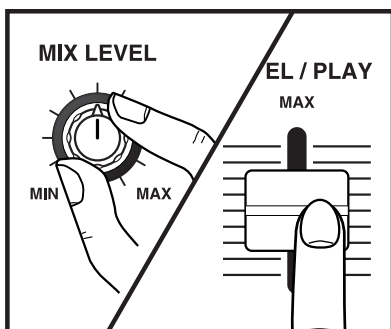

#### 4. PLAYBACK

Set MIX volume to suitable level. Playback starts at the same time LEVEL/PLAY VOLUME is raised. By pushing LOOP switch, loop playback will start.

## OVER DUBBING

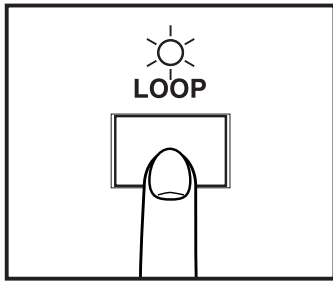

### 1. Turn on loop playback mode

Push LOOP switch and set to loop playback mode. (Please check that the LOOP indicator is on at this time.)

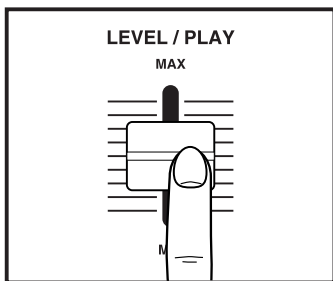

### 2. Start loop playback

LEVEL/PLAY volume is raised and playback is started.

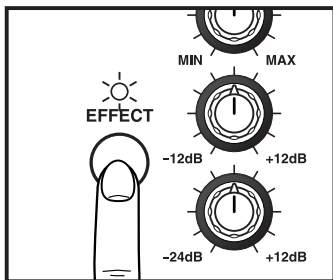

### 3. Select the channel to record

Push switch that you want to record and check the EFFECT indicator is on.

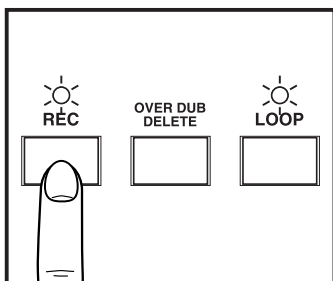

### 4. Over dubbing

During loop playback, push REC switch at the point you want to start over dubbing. Over dubbing will be stopped if a REC switch is pushed again. (In case a scratch play is recorded, when both hands are full, it is convenient that a foot pedal is connected to FOOT jack and you can use it as a REC switch.)

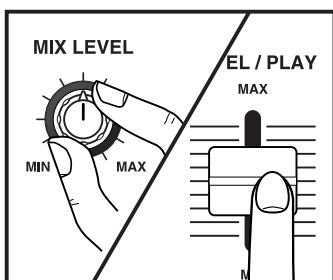

### 5. Playback

When you raise MIX fader with LEVEL/PLAY volume being raised, playback starts at the same time.

## HOW TO CHANGE THE FADER UNIT

How to remove a top panel

As shown in fig-a, please remove the knob of INPUT LEVEL volume, CROSS FADER volume, MONITOR-LEVEL volume, C.F.MONITOR volume, and LEVEL / PLAY volume. (A total of six pieces)

As shown in fig-a, please use a plus screwdriver (size: No.1), and remove the screw of four points which is fixing the top panel.

As shown in fig-b, please remove the screw of two points which is fixing the fader panel, and raise upwards the whole fader unit, after removing a top panel.

Please pull and remove the connector which has connected the main part side with the fader unit. (Be careful not to bend the pin of a connector in this case)

Remove the fader knob of new fader unit.

Attach multi-cable connector to new fader unit.

Position the new fader unit carefully and secure with screws.

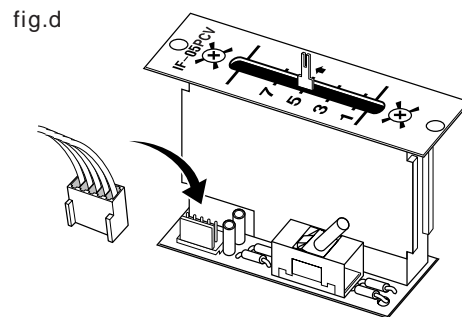
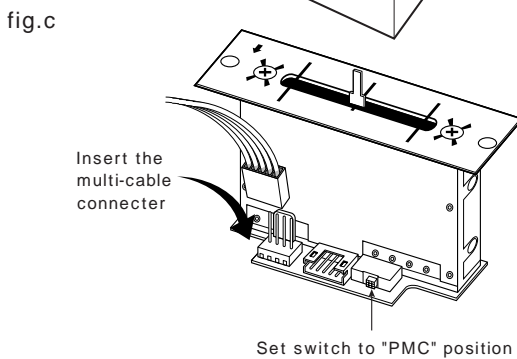
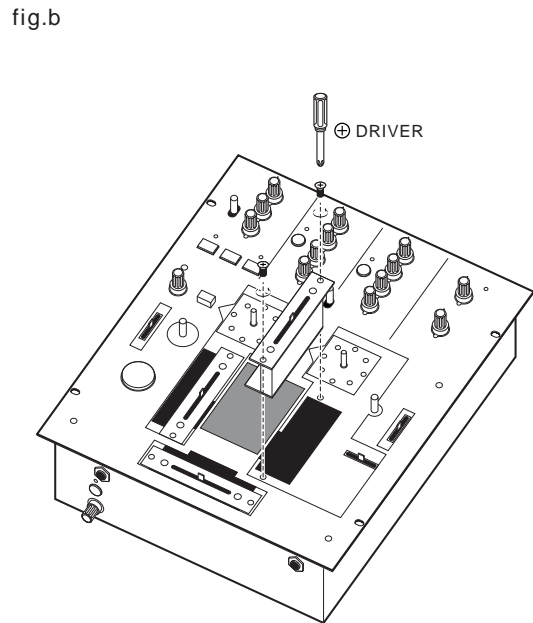
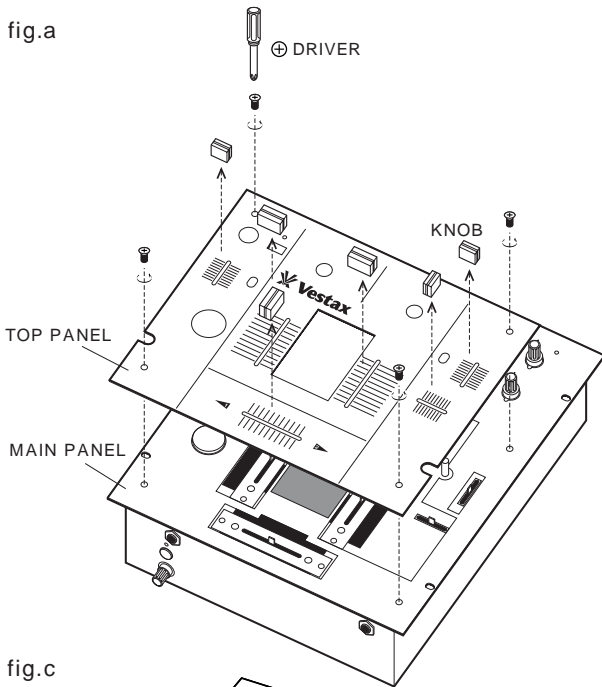

### How to change input select switch

remove the top panel in the same procedure.  
 Remove the two screws which fix the switch panel, fix the switch panel, and remove the switch unit from position in mixer.(See fig-e)

Carefully remove the multi cable connector from the switch unit(See fig-f)  
 Attach multicable connector to new switch unit.  
 Position the switch unit carefully, and the secure with the screws.

### How to change the direction of the switch

remove the top panel in the same procedure.  
 Remove the two screws which fix the switch panel, fix the switch panel, and remove the switch unit from position in mixer.(See fig-e)

Change the direction,and the secure with screws.  
 Replace the top panel and secure with screws.

fig.e

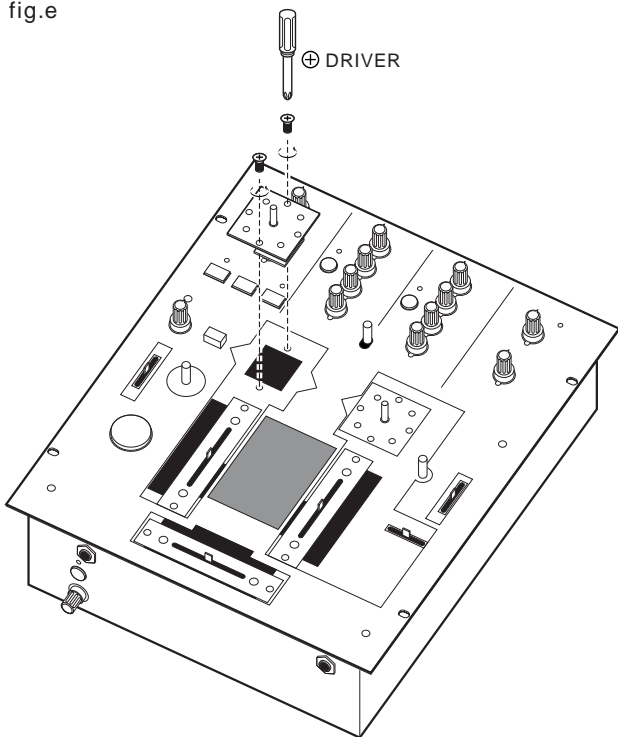
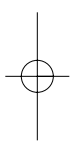
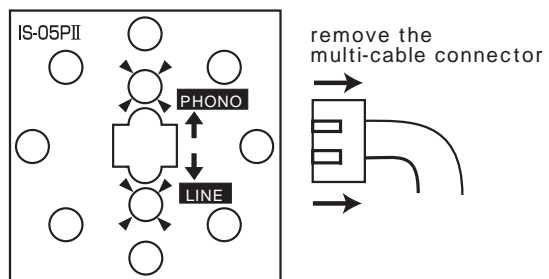
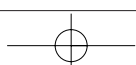

fig.f



INF
OU
EQ
etc



# CONNECTION

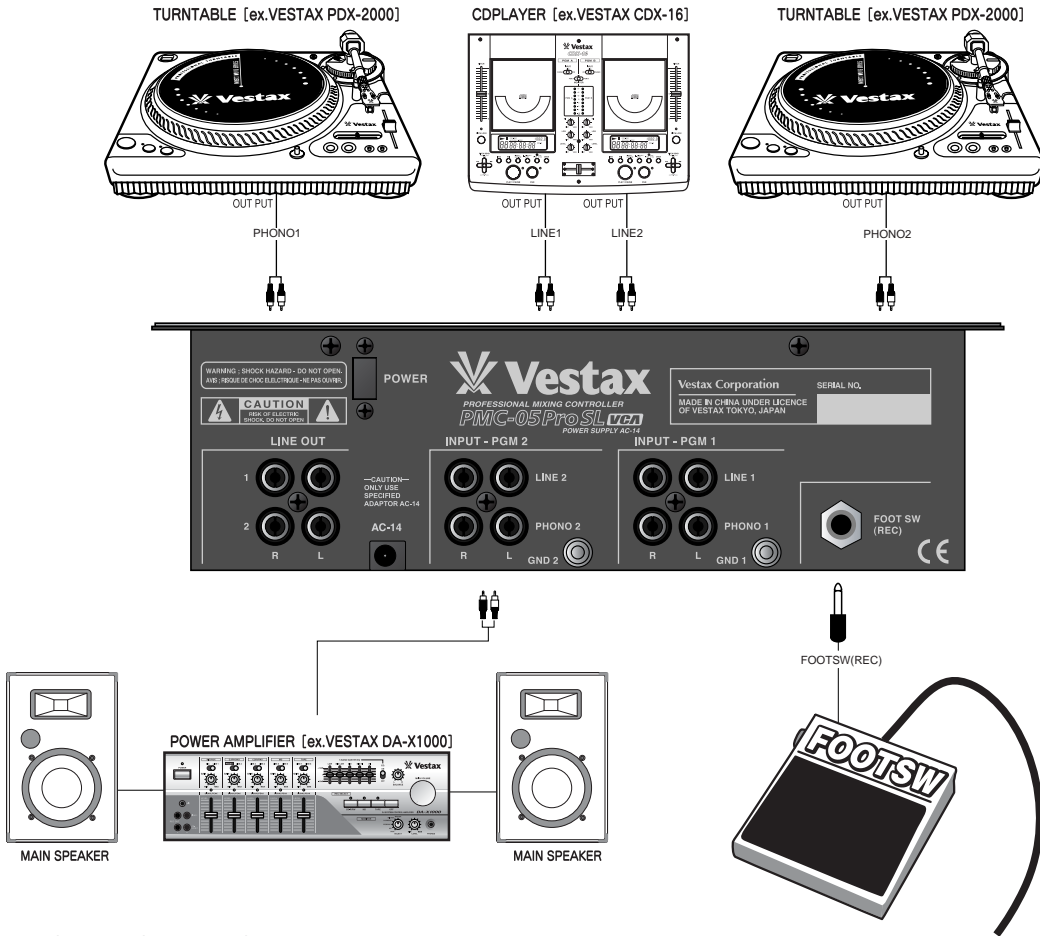

# SPECIFICATION

		NOMINAL INPUT LEVEL	IMPEDANCE
INPUT	MIC IN:( 6.3 PHONE / UNBLANCED dBv )	-50dBv	3k
	PHONO IN:PGM-1 ~ 2( RCA PIN / UNBLANCED dBv )	-45dBv	45k
	LINE IN:PGM-1 ~ 2( RCA PIN / UNBLANCED dBv )	-10dBv	10k
OUTPUT		NOMINAL OUTPUT LEVEL	IMPEDANCE
	MASTER OUT	-10dBv	220
EQ	EQUALIZER	:HI	10kHz( ± 12dB ) SHELVING TYPE
		:LOW	60Hz(+12, -24dB) PEAKING TYPE
	FREQUENCY RESPONS	:LINE	20Hz ~ 20kHz ± 1dB
	S/N RATIO	:LINE	75dB
	CROSS TALK	:C.F.	80dB
	THD		< 0.01%
etc.	POWER SUPPLY	AC-14V 1000mA	
	POWER	10W	
	WEIGHT	4kg	
	SIZE(W x H x D)	( W x H x D )103 x 320 x 262( mm )	