



FROSTBYTE



V2 & V3

Water Methanol Controller

User Guide

turnerd.com

Contents

Hardware Requirements	3
Installation Location	3
Wiring Colour Codes.....	3
Software Interface.....	6
Overview	6
Connection	6
3D Tables.....	7
Settings.....	8
Fuel Injection Mode	8
Pump settings.....	9
Map Sensor	9
Other Settings	9
Solenoid.....	9
Failsafe.....	10
Mass Airflow Sensors	12
Testing.....	13
Testing Pump output.....	13
Testing Solenoid	13
Appendix	14
Pump Wiring.....	15

Hardware Requirements

We recommend that you install **FrostByte** on a gasoline or diesel-powered vehicle with forced induction or nitrous. Naturally aspirated vehicles can be fitted as well but must be tuned by an experienced calibrator. Specific hardware requirements are:

- Switched 12v power source and a solid ground.
- MAP or MAF sensor signal to be tapped.
- Methanol pump and fast acting solenoid already plumbed into system.
- Low level sensor.
- *Low pressure switch or sensor (not required but recommended)*

Installation Location

Do not install inside the engine bay – the plastic case will not tolerate the heat. Anywhere reasonable inside the cabin should be fine.

Wiring Colour Codes

WARNING: Never connect the pump directly to the unit. A relay is necessary! See the end of this document for relay wiring instructions!



FROSTBYTE V3 WIRING DIAGRAM

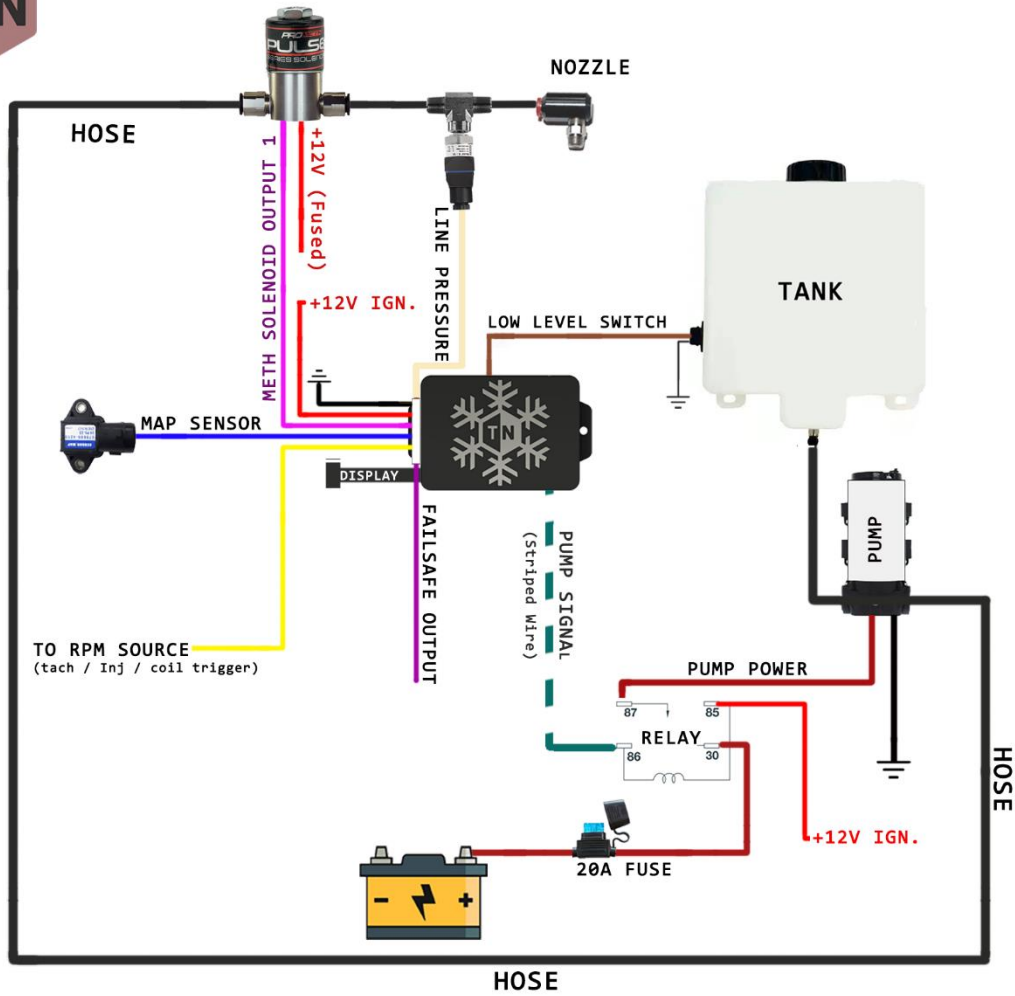

PWR	RPM	LOW FLUID	5V OUT	MAP/MAF	FROM ECU BCS / FAILSAFE OUT	METH OUT 2
GND	METH OUT 1	GND 2	LINE PRESSURE SENSOR	PUMP RELAY	TO BCS	WARN LED +ve

The preceding diagram represents both the pinout at the device connector and wire colour codes. The order of the pins shown here represents the view looking into the device's connector and not the wire harness connector.

PWR – (RED) Ignition key switched 12V supply.

GND – (BLACK) Solid ground that ECU uses.

RPM – (YELLOW) Engine speed source which can be tacho or injector. If injector duty cycle mode is used for flow calculations, then this RPM source must be from an injector. Direct injectors are not supported for RPM signal.

METH OUT 1 – (PINK) Switched GND signal for the FIRST fast-acting methanol solenoid. The solenoid has constant switched 12V on one wire and the other connects to this wire. Polarity doesn't matter. A regular on/off solenoid can be used here as well.

LOW FLUID – (BROWN) This connects to the low-level sensor. The sensor has 2 wires, one must be grounded and the other connected to this brown wire.

5V OUT– (ORANGE) Optional 5V source that may be used on a dedicated map sensor or the line pressure sensor.

LOW Pressure – (TAN) For low pressure sensor, or low-pressure switch. This is either used as 5-volt low-pressure sensor or low-level pressure switch. To configure for either, refer to appendix 1 at the end of document. By default, it's configured for pressure switch.

NOTE: Low pressure can only be tested under "spraying" on conditions. If the system is not currently spraying/injecting, then the fault will not be detected. This is because the system only expects line pressure once the pump is on AND duty cycle greater than 1% is currently commanded.

MAP/MAF – (BLIE) Map or MAF Sensor signal. Configurable for each in software.

PUMP RELAY –(Striped wire). Use this output to turn on a pump relay. It is a negative output (-12v), so connect this to a relay, and the other wire of the relay to +12V. See the end of this document for diagram.

TO BCS / FAILSAFE OUT– (PURPLE) This wire can either be used as the failsafe signal to the ecu input (12V signal) (1) or it can be used to intercept the boost control signal from your ECU (2).

- 1) To use it as signal for your ecu, simply connect this wire to an ECU input of your choice. You must then configure this input to handle your failsafe strategy. This is a 12V signal.
- 2) To use this signal to drop boost to wastegate pressure, you must identify the two wires the ecu sends to the boost control solenoid. One wire is constant 12v, the other is a pulsed ground. At the ecu end of the loom, cut the signal wire that the ECU sends to the Boost Control Solenoid. Connect the side of the wire from the ecu to the FrostByte purple wire. Connect the Frostbyte white wire to the other side of the cut wire that goes out to the BCS. Under failsafe conditions FrostByte will drop the boost to wastegate pressure.

BCS –This goes to the BCS. If no BCS is being used or a simple map switch signal is required, then connect this wire to ground.

METH OUT 2 –SECOND fast-acting methanol solenoid switched ground output.

WARN LED – LED output. Connect this to a regular LED of your choice. This wire is the positive (+) side, it is therefore expected that the other wire of the LED goes to GND. **DO NOT APPLY CURRENT TO THE LED!**

2 blinks = Pressure error

3 blinks = Fluid low

Software Interface

Overview

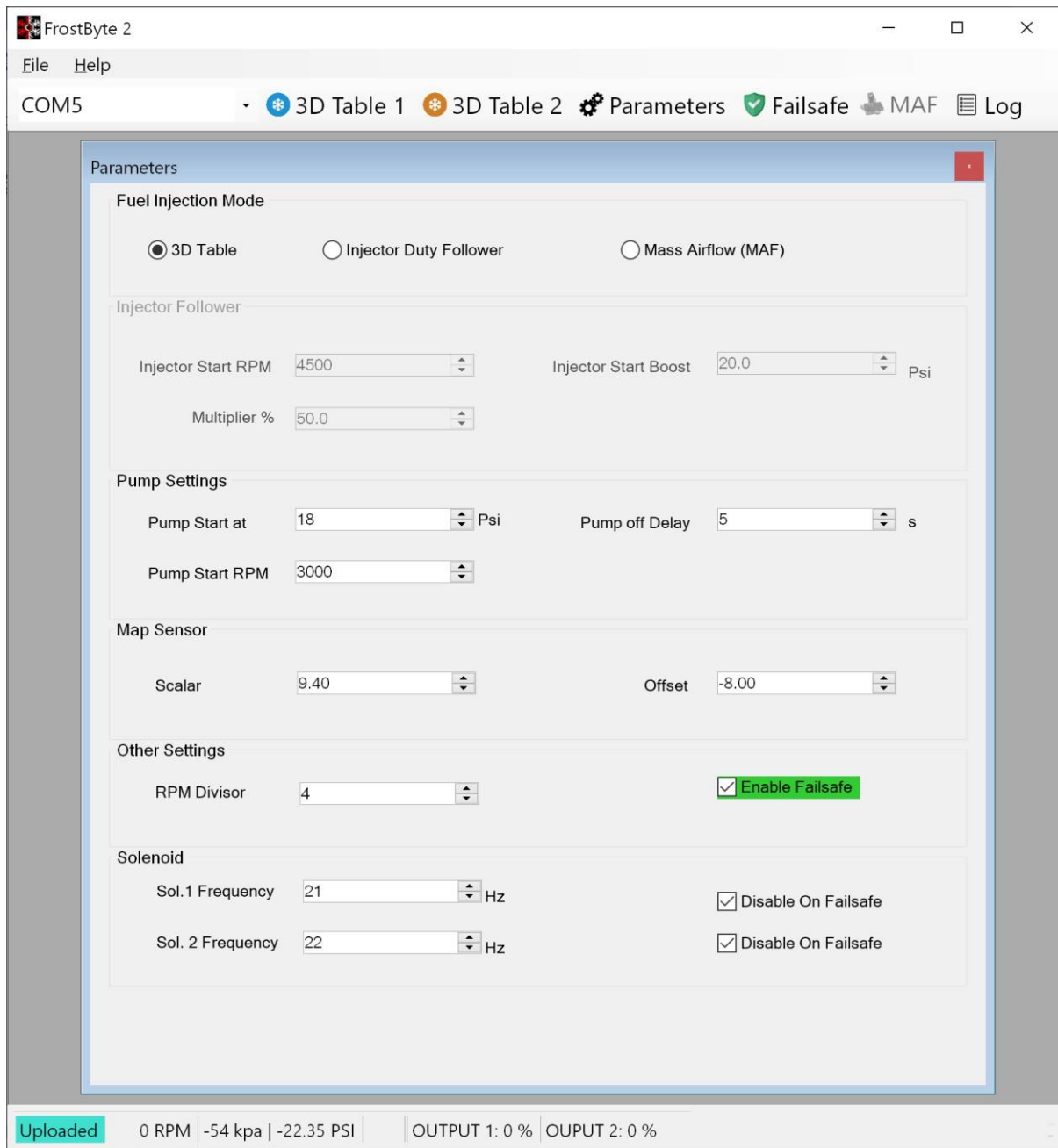

Connection

The software uses USB COM port to communicate with the device. Please select the correct port. COM5 in the photo above is just an example, your PC may assign a different number to your device. If more than one port is in the list, try each until you get a connection.

3D Tables

There are two 3D tables that can be used for fluid flow control. The 3D tables are based on boost vs RPM. The number in the table is the flow %. We call this the duty cycle. The higher the duty cycle the more methanol will spray.

3D Table 1

MAP (PSI-G) Shortcut keys

RPM	-10	8.7	11.6	14.5	17.4	23.2	26.1
0	0	0	0	0	0	0	0
2000	0	0	40	40	40	40	40
4800	0	0	43	44	45	47	48
5600	0	0	45	47	49	54	56
6400	0	0	48	51	54	61	64
7200	0	0	51	55	59	68	72
8000	0	0	53	58	64	75	80
8800	0	0	56	62	69	82	88
9600	0	0	59	66	74	89	96
15000	0	0	60	68	76	92	100

Live Tracking

Shortcuts

To quickly change values in the 3D table:

Increase value: SHIFT+ UP arrow

Decrease value SHIFT+DOWN arrow

Interpolate – \

Settings

The screenshot shows a 'Parameters' window with the following sections and settings:

- Fuel Injection Mode:** Three radio buttons are present: '3D Table' (selected), 'Injector Duty Follower', and 'Mass Airflow (MAF)'.
- Injector Follower:** Contains three spinners: 'Injector Start RPM' (4500), 'Multiplier %' (50.0), and 'Injector Start Boost' (20.0) with a 'Psi' label.
- Pump Settings:** Contains four spinners: 'Pump Start at' (6) with a 'Psi' label, 'Pump Start RPM' (2500), 'Pump off Delay' (5) with an 's' label, and 'Pump off Delay' (5) with an 's' label.
- Map Sensor:** Contains two spinners: 'Scalar' (10.00) and 'Offset' (-9.00).
- Other Settings:** Contains one spinner 'RPM Divisor' (4) and a checked checkbox 'Enable Failsafe'.
- Solenoid:** Contains two rows, each with a spinner for frequency and a checkbox for 'Disable On Failsafe':
 - Sol. 1 Frequency: 25 Hz, checkbox unchecked.
 - Sol. 2 Frequency: 15 Hz, checkbox unchecked.

The parameters page has a number of settings which will determine how the device works.

Fuel Injection Mode

- 3D table (default) - Methanol will be injected as per duty cycle of a 3D table.
- Injector duty follower - this will read your injector duty cycle and apply a multiplier that will determine the water injection duty. The Frostbyte RPM source must be at the injectors for this to work.
- MAF – use the mass airflow sensor to determine methanol output.

Pump settings

- Pump start boost – The relative PSI that will trigger the pump to turn on. This does not spray but only pressurizes the line.
- Pump start RPM – While Over this RPM the pump will always be on.
- Pump off Delay – How long does the pump stay on AFTER the RPM and boost is below their threshold.

Map Sensor

- Scalar - This is the map sensor scalar (multiplier) value.
- Offset – This is the map sensor offset value. If map pressure values are not matching the ecu's map pressure, adjust the offset until they say the same thing.

Other Settings

- RPM Divisor – Adjust this value until the correct RPM reading is displayed.
- Enable Failsafe – This enables the failsafe output (BCS)
 - Invert low level – For example, if the tank is full and the software is showing a low-level error, then the switch is giving an opposite reading. Flip this checkbox to invert the reading.
 - Invert low pressure - Same as above. If pressure is giving opposite reading, flip this checkbox to correct it.

Solenoid

- Frequency - This is the frequency that the fast-acting solenoid output will pulse at. The default is **20Hz** as this gives a good response across many solenoids.
- This output can be used as pump speed control, but a DC current solid-state relay is an **absolute MUST**. Otherwise, this will burn the device output. For pump flow control the frequency should be much higher, around 100 Hz.
 - Note: Some solid state relays do not work well above 100hz

Failsafe

FrostByte can interrupt signals to the boost control solenoid in the event of a failsafe condition. These include low fluid and low-pressure conditions.

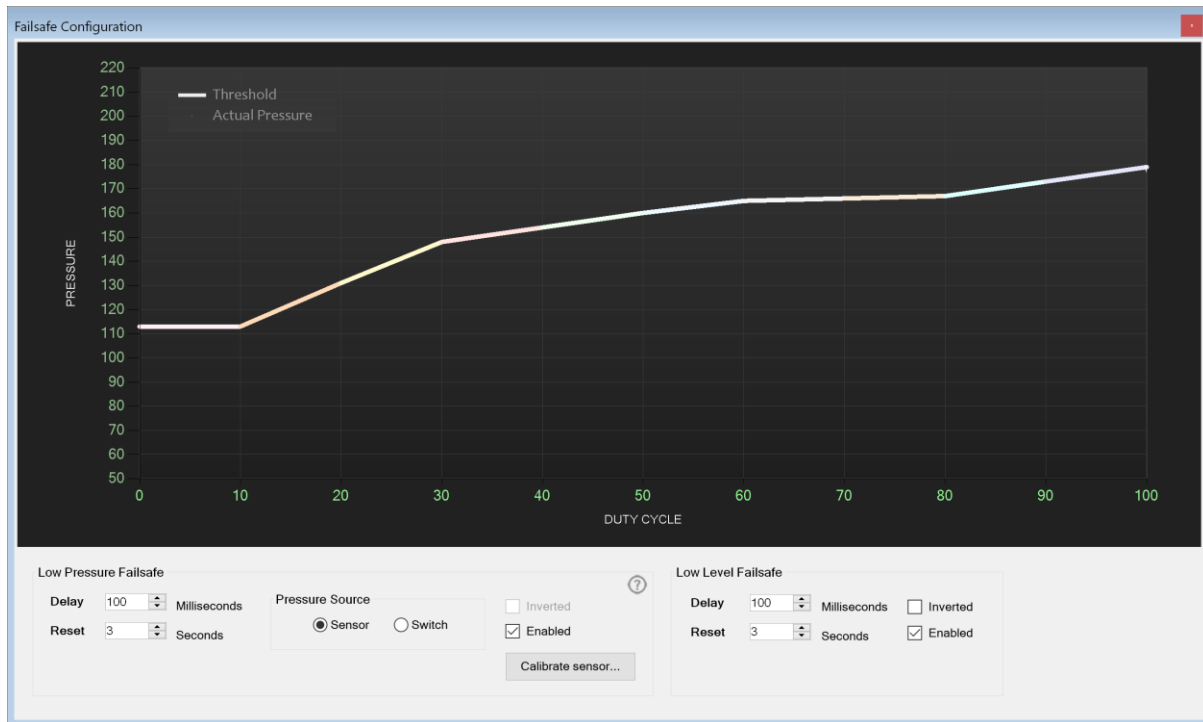

Failsafe Configuration screen determines how the system handles low fluid and low-pressure situations.

- Pressure source
 - Pressure switch or sensor. Configurable via a jumper on the circuit board. (see appendix)
 - NOTE: The pump must be triggered by the device before a low-pressure fault can be detected. To trigger the pump and test the low-pressure fault refer to the testing procedure a few pages below.
 -
- Delay
 - How long after detecting an adverse situation that it waits before triggering the failsafe.
- Reset
 - How long after normal operation is restored before removing failsafe.
- Inverted

- Gives the option to invert the signal. Low becomes high, and high becomes low.

In the event of a failsafe condition the boost control solenoid will be bypassed and the boost will drop to wastegate spring pressure. The solenoid will therefore not engage higher boost beyond the wastegate pressure. Also, **the solenoid will not receive signals to engage higher boost if “pump min RPM” or “min boost pressure” settings are not met. This is an added safety precaution to prevent high boost in the unlikely event of a device malfunction. If you need to engage the boost control solenoid earlier, please lower the PUMP min RPM or PUMP min boost to suit.**

Failsafe LED

The device can blink LED if it detects a low level or low-pressure fault.

Low level: LED blinks

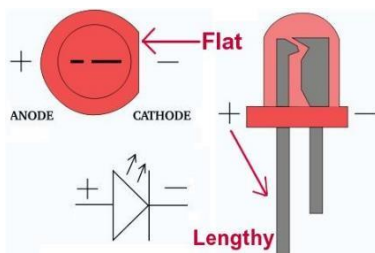

V3 devices will not need to use this output as their LCD displays will show the specific failsafe / fault.

MAF - Mass Airflow Sensor

A lot of cars are equipped with Air flow sensors that measures the approximate amount of air entering the engine. Frostbyte can use this sensor to determine how much fluid to flow. This graph allows you to configure fluid flow vs airflow. In the photo below, the user is hovering over a point that indicates 35% flow @ 214 grams of air per second.

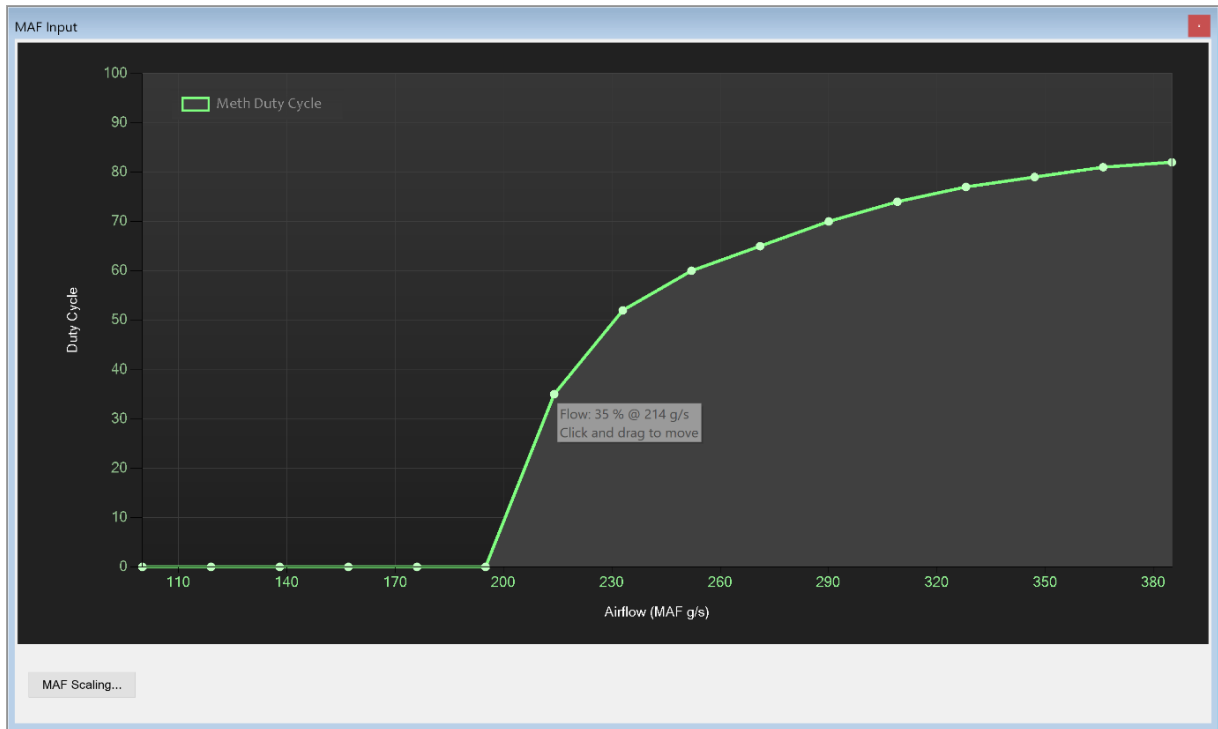

MAF Scaling

MAF Scaling

Volts	Grams /sec
2.38	30
2.46	33
2.5	35
2.53	37
2.61	40
2.69	45
2.77	49
2.85	54
2.92	59
3	64
3.08	70
3.16	76
3.24	82
3.32	88
3.39	96
3.47	103
3.55	111
3.63	119
3.71	128
3.78	137
3.86	147
4.02	168
4.17	190
4.33	214

Mass Air Flow Sensor Type
 Voltage Frequency

Save Cancel

We allow the user to input their own MAF scaling. This may be done by copying the table from their ECU into excel sheet. Or simply making a table in excel and copy/paste into the table here.

Two types of sensors are supported: voltage and frequency based.

Testing

Testing Pump output

The pump will be triggered in two ways. Once the RPM or boost threshold is passed, or if the active Methanol Duty cell contains a positive value. IF the car is idling or even just ignition on, the pump will be triggered if a positive value is placed in this cell as shown below:

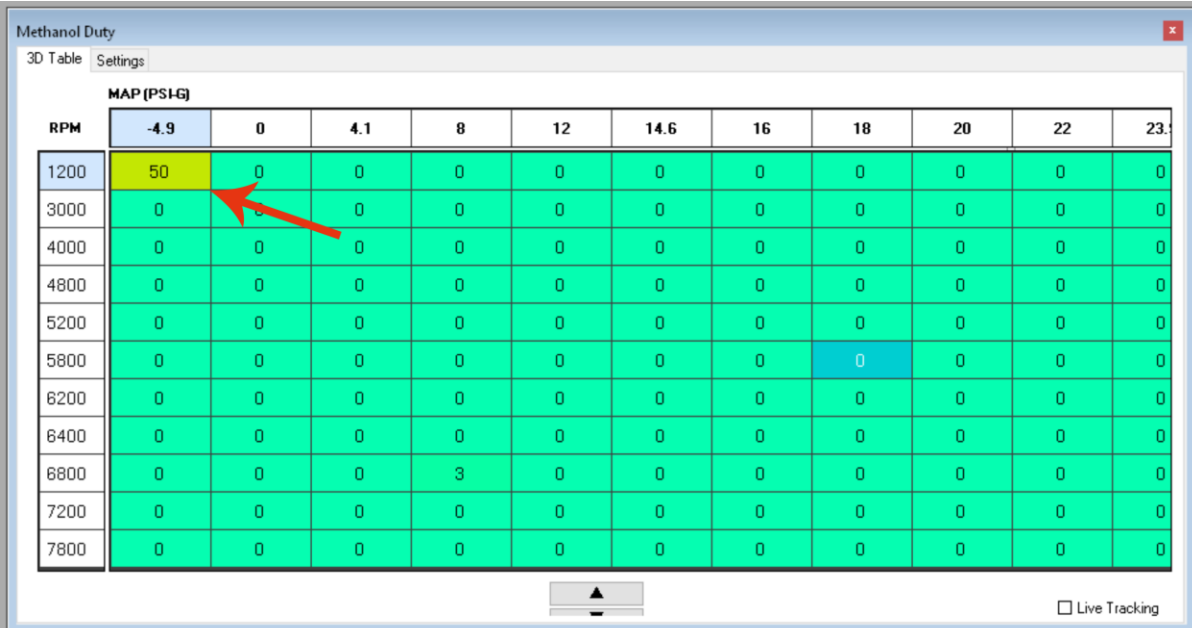

The screenshot shows a software window titled "Methanol Duty" with a "Settings" tab. It displays a 3D table with "MAP (PSI-G)" on the horizontal axis and "RPM" on the vertical axis. The table has 12 columns for MAP values (-4.9, 0, 4.1, 8, 12, 14.6, 16, 18, 20, 22, 23.1) and 12 rows for RPM values (1200, 3000, 4000, 4800, 5200, 5800, 6200, 6400, 6800, 7200, 7800). The cell at 1200 RPM and 0 PSI-G is highlighted in yellow and contains the value 50. A red arrow points to this cell. The cell at 5800 RPM and 18 PSI-G is highlighted in blue and contains the value 0. A "Live Tracking" checkbox is visible at the bottom right.

RPM	-4.9	0	4.1	8	12	14.6	16	18	20	22	23.1
1200	50	0	0	0	0	0	0	0	0	0	0
3000	0	0	0	0	0	0	0	0	0	0	0
4000	0	0	0	0	0	0	0	0	0	0	0
4800	0	0	0	0	0	0	0	0	0	0	0
5200	0	0	0	0	0	0	0	0	0	0	0
5800	0	0	0	0	0	0	0	0	0	0	0
6200	0	0	0	0	0	0	0	0	0	0	0
6400	0	0	0	0	0	0	0	0	0	0	0
6800	0	0	0	3	0	0	0	0	0	0	0
7200	0	0	0	0	0	0	0	0	0	0	0
7800	0	0	0	0	0	0	0	0	0	0	0

Testing Solenoid

Likewise, the solenoid will start pulsing once a positive value is entered here, or if the active cell has a positive value. Please note, due to the mechanical limitation of the solenoid some solenoids won't begin to pulse until after 20% is entered in the cell. Also, the higher the set solenoid frequency the higher this threshold will be.

Appendix

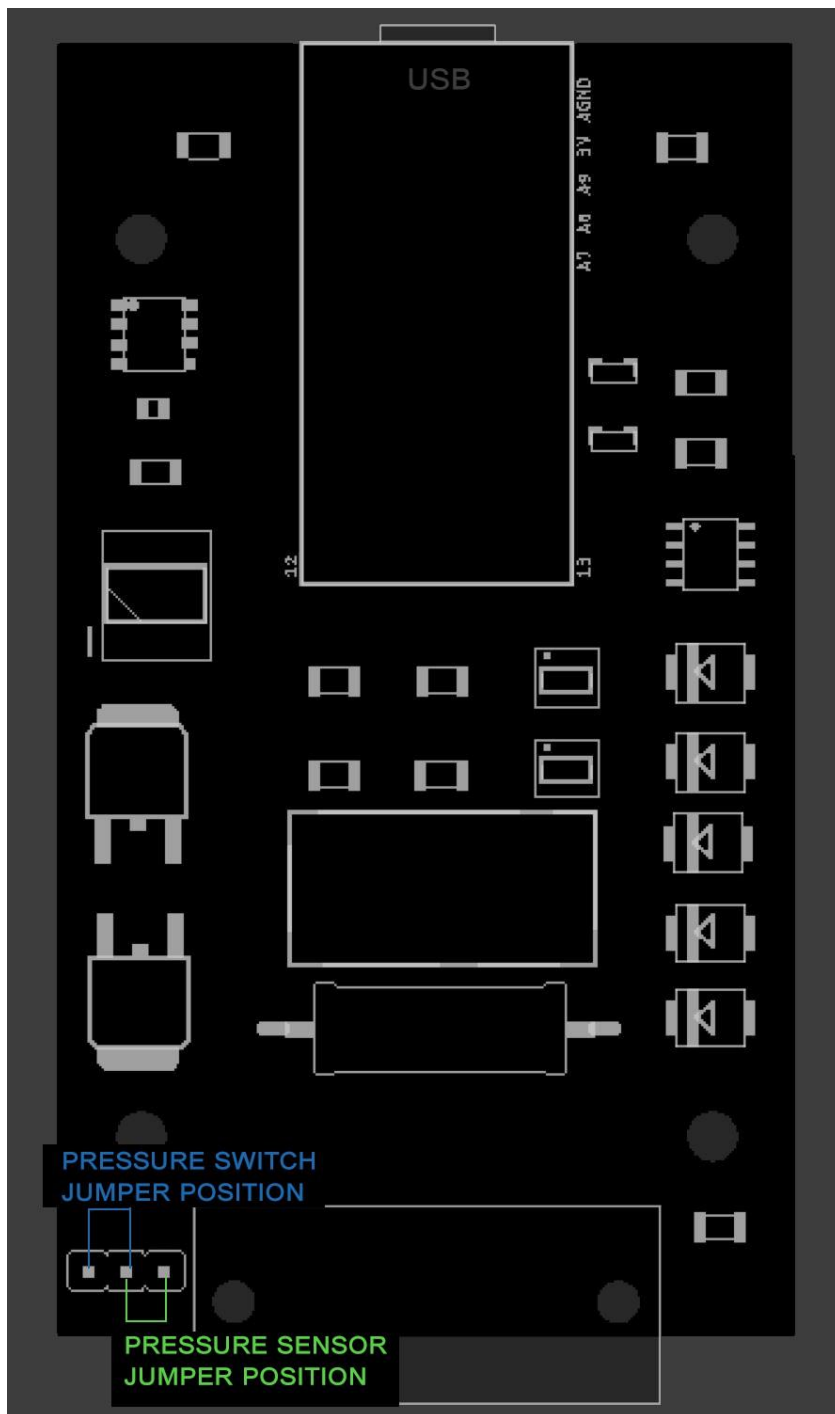

Appendix 1 - Low Pressure Jumper

Pump Relay connection

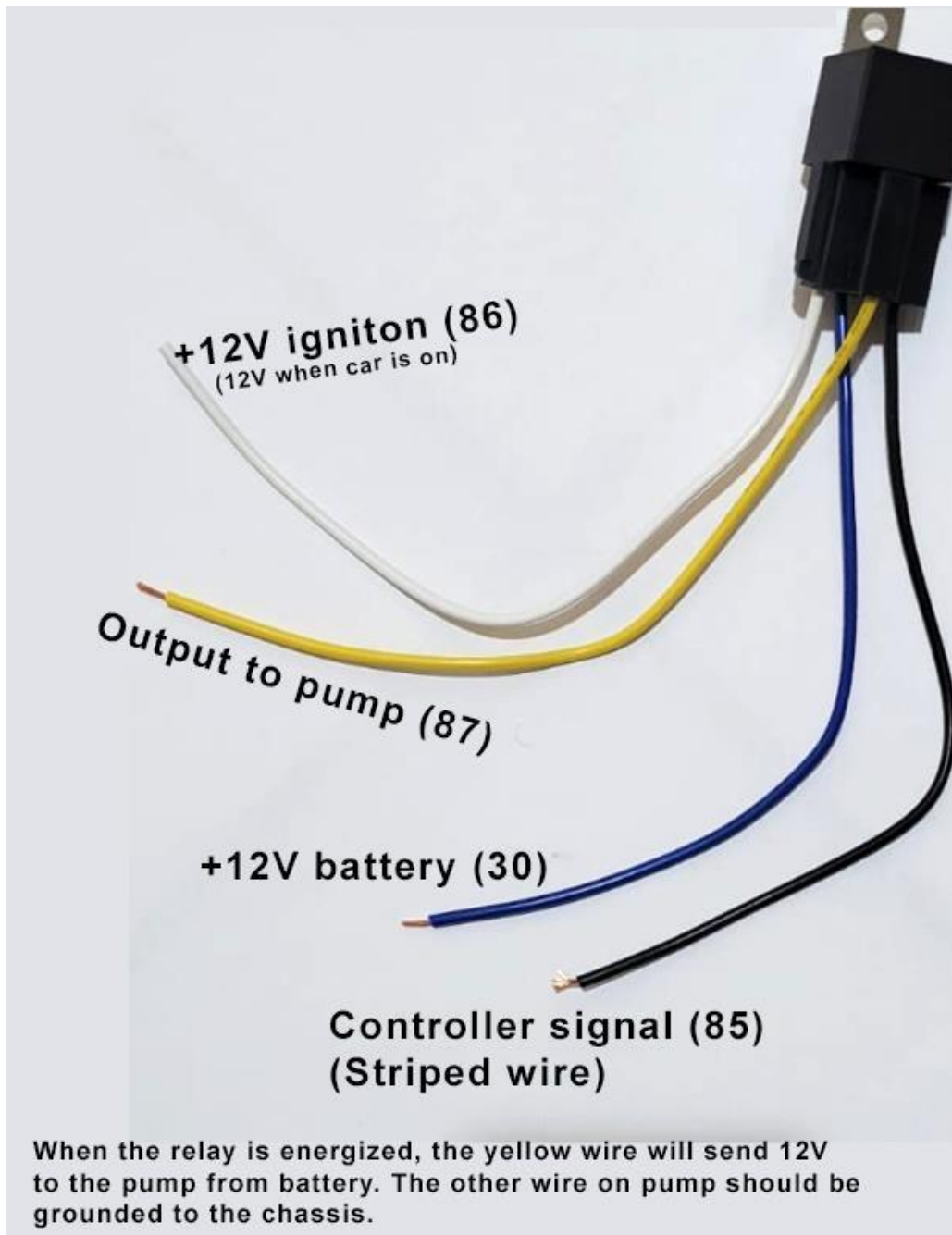

- Note: the “+12V battery (30)” wire is expected to be connected directly to battery
- The +12V ignition (86) wire should go to the key on 12V source, meaning only when car is on should this wire be getting 12V.
- Output to pump goes directly to pump positive wire
- The pump’s black wire (not in the picture) should be grounded to chassis.