

STAINLESS STEEL FLANGED BALL VALVE

WATERMARK APPROVED

MODEL - SSRV2F



FEATURES AND BENEFITS

- For Potable Water Applications
- WaterMark Approved
- 2 Piece Stainless Steel Construction
- Flanged Ends Drilled AS2129 Table E
- Full Bore
- Lockable Lever Handle
- Blowout Proof Stem
- Investment Cast Body
- Pressure Rating: ANSI Class 150
- Working Temperature: -20°C~200°C

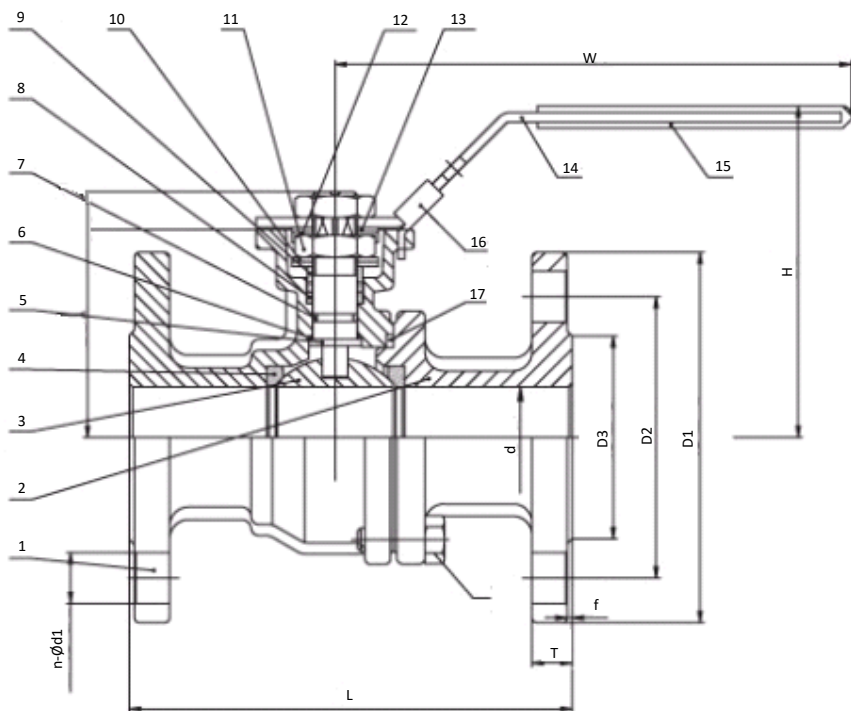

NO.	PART NAME	MATERIAL
1	Body	ASTM A351-CF8M
2	Cap	ASTM A351-CF8M
3	Ball	ASTM A276-316
4	Seat	RTFE
5	Stem	ASTM A276-316
6	Thrust Washer	PTFE
7	O-Ring	VITON
8	Stem Packing	PTFE
9	Gland	AISI 304
10	Washer	AISI 301
11	Nut	AISI 304
12	Washer	AISI 304
13	Stop Pin	AISI 304
14	Handle	AISI 304
15	Handle Sleeve	PVC
16	Locking Device	AISI 304
17	Body Gasket	PTFE
18	Bolt	AISI 304

DIMENSIONS														
DN	Inch	d	L	T	f	D1	D2*	D3	n-d1*	H1	H	P	ISO 5211	N.m (Kg)
15	½"	15	108	10	1.6	89	67	35	4-14	48	80	9	F03/F04	6 1.6
20	¾"	20	117	11	1.6	99	73	43	4-14	53	85	9	F03/F04	10 2.0
25	1"	25	127	11	1.6	108	83	51	4-14	59	95	11	F04/F05	12 2.8
32	1-¼"	32	140	13	1.6	117	87	64	4-14	71	108	11	F04/F05	17 3.9
40	1-½"	38	165	15	2	125	98	73	4-14	76	114	14	F05/F07	30 5.1
50	2"	50	178	16	2	150	114	92	4-18	85	124	14	F05/F07	48 7.2
65	2-½"	65	190	18	2	180	127	105	4-18	102	148	17	F07/F10	58 13
80	3"	76	203	20	2	190	146	127	4-18	112	158	17	F07/F10	96 16
100	4"	94	229	24	2	230	178	157	8-18	141	191	17	F07/F10	124 26

*AS2129 Table E drilling pattern.

