

STAINLESS STEEL LUGGED BUTTERFLY LEVER HANDLE MODEL - SSLSSN

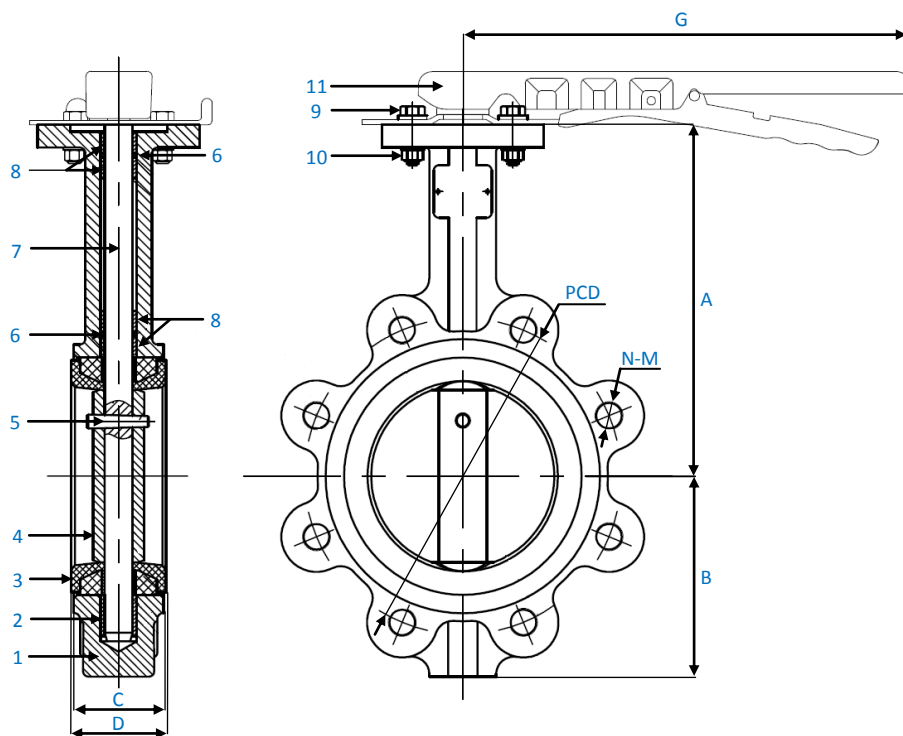

FEATURES AND BENEFITS

- For Industrial, Chemical & General Applications
- Stainless Steel 316 Construction
- Lugged to suit AS2129 Table E
- Stainless Steel 316 Lever Handle
- Blowout Proof Stem
- Investment Cast Body Construction
- Top flange to ISO5211
- Pressure Rating: PN10



NO.	PART NAME	MATERIAL
1	Body	Stainless Steel CF8M
2	Long Bushing	PTFE
3	Seat	Nitrile
4	Disc	Stainless Steel CF8M
5	Taper Pin	Stainless Steel
6	O-Ring	Nitrile
7	Shaft	Stainless Steel 316
8	Short Bushing	PTFE
9	Bolts	Steel
10	Nuts	Steel
11	Lever	Stainless Steel 316

APPLICATIONS

Challenger Valves and Actuators are the **“Right Choice for Valves and Actuation”** when quality matters.

Servicing industries such as : Water & Waste Water, Mining, Desalination, Pumping, Industrial Processing, Irrigation, Materials Handling and Chemical Services.

DN	A	B	C	D	G	PCD	N-M
80	161.8	89	45	49.1	259	146	4-M16
100	178	107	51	55.3	259	178	8-M16
150	205.2	138	54.5	59.1	259	235	8-M20
200	237	171	59.6	64.1	373	292	8-M20