

STAINLESS STEEL 3 WAY BALL VALVE DIRECT ISO MOUNTING PAD MODEL - SS2057D

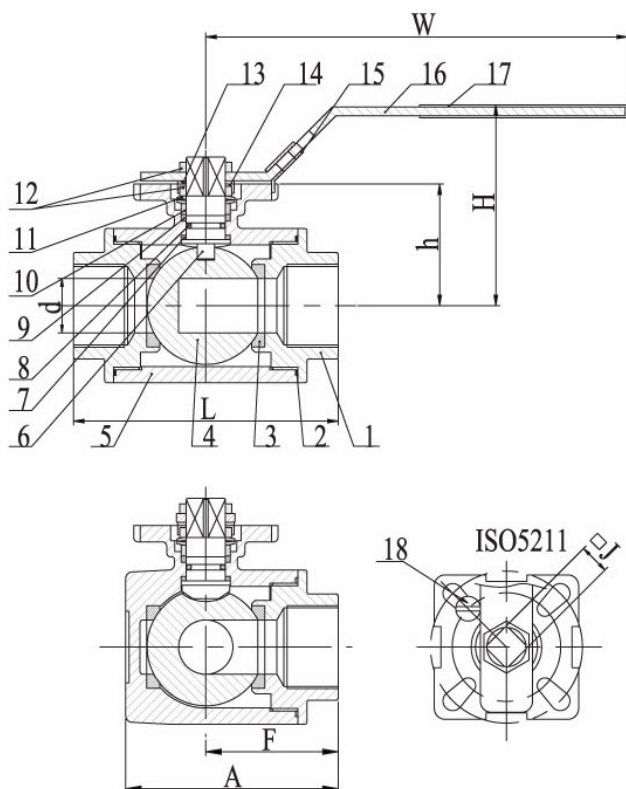

FEATURES AND BENEFITS

- For Industrial, Chemical & General Applications
- Threaded BSPT Ends
- Lockable Lever Handle
- ISO 5211 Direct Mounting Pad
- Blowout Proof Stem
- Reduced Bore
- Investment Cast Body Construction
- Pressure Rating:1000PSI
- Working Temperature: -20°C~200°C
- Testing to API598



NO.	PART NAME	MATERIAL
1	Cap	CF8M
2	Gasket	PTFE
3	Ball Seat	PTFE
4	Ball	SS316
5	Body	CF8M
6	Stem	SS316
7	Thrust Washer	PTFE
8	O-Ring	Viton
9	Stem Packing	RTFE
10	Stem Ring	SS316
11	Washer	SS301
12	Nut	SS304
13	Plate Washer	SS304
14	Nut Stopper	SS304
15	Lock Device	SS304
16	Handle	SS304
17	Handle Cover	Plastic
18	Stop Pin	SS304

APPLICATIONS

Challenger Valves and Actuators are the **“Right Choice for Valves and Actuation”** when quality matters.

Servicing industries such as:

Water & Waste Water, Mining, Pumping, Industrial Processing, Irrigation, Materials Handling and Chemical Services.

DIMENSIONS											
DN	d	L	H	h	W	F	A	J	ISO5211	Torque (Nm)	(Kg)
8	9.5	75	66	36.8	130	37.5	57.5	9	F03/F04	8	0.70
10	11	75	66	36.8	130	37.5	57.5	9	F03/F04	8	0.67
15	12	75	66	36.8	130	37.5	57.5	9	F03/F04	8	0.63
20	15	85	72	41.2	161	42.5	65.5	11	F04/F05	9	0.94
25	20	100	77	46.5	161	50.0	79.0	11	F04/F05	15	1.38
32	25	122	92	56	203	61.0	97.0	14	F05/F07	20	2.91
40	32	131	96	60	203	65.5	106.5	14	F05/F07	30	3.60
50	40	158	107	70.5	203	79	129	14	F05/F07	45	6.31
65	49	178	135	95.5	254	89	145	17	F07/F10	60	8.95
80	60	202	147	106	254	101	167	17	F07/F10	90	13.11

STAINLESS STEEL 3 WAY BALL VALVE DIRECT ISO MOUNTING PAD MODEL - SS2057D



FLOW PATTERNS FOR 3-WAY BALL VALVE

The basic type of actuator to suit the SS2057D is a 1/4 turn actuator with only two flow positions available. As standard an L or T port would be supplied as port 1-2 unless otherwise specified.

PORT TYPE \	1	2	3	4
L				
T				

SS2057D BALL VALVE SIZING CHART

Size	Double Acting Pneumatic Actuator	Spring Return Pneumatic Actuator	Electric Actuator
8mm	HP-DA050	HP-SR063	HQ006
10mm	HP-DA050	HP-SR063	HQ006
15mm	HP-DA050	HP-SR063	HQ006
20mm	HP-DA063	HP-SR075	HQ006
25mm	HP-DA063	HP-SR075	HQ006
32mm	HP-DA075	HP-SR088	HQ006
40mm	HP-DA075	HP-SR088	HQ006
50mm	HP-DA075	HP-SR100	HQ006
65mm	HP-DA088	HP-SR125	HQ015
80mm	HP-DA100	HP-SR125	HQ015

Note: If 415V AC is required, consult Challenger.

PRESSURE-TEMPERATURE RATING

