

# STAINLESS STEEL Y STRAINER

## BSP THREADED 8 - 50MM

### MODEL - SS2049



#### FEATURES AND BENEFITS

- For Industrial, Chemical & General Applications
- 316 S/S Construction
- Threaded BSPT Ends
- Investment Cast Body
- Pressure Rating: 800PSI WOG
- Working Temperature: -20°C~200°C
- Testing to API598

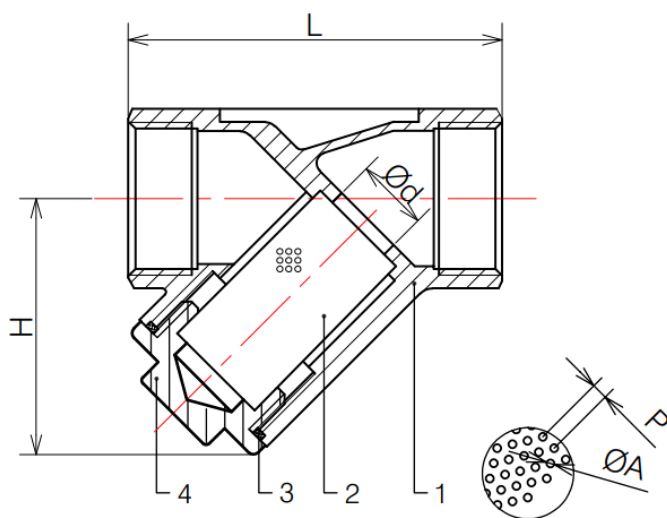

Section A-A

| NO. | PART NAME    | MATERIAL  |
|-----|--------------|-----------|
| 1   | Body         | A351-CF8M |
| 2   | Screen       | SS316     |
| 3   | Joint Gasket | PTFE      |
| 4   | Bonnet       | A351-CF8M |

| DIMENSIONS |    |     |      |   |    |      |
|------------|----|-----|------|---|----|------|
| DN         | Ød | L   | H    | P | ØA | (Kg) |
| 8 (¼")     | 10 | 64  | 43   | 2 | 1  | 0.20 |
| 10 (¾")    | 12 | 64  | 43   | 2 | 1  | 0.17 |
| 15 (½")    | 15 | 64  | 43   | 2 | 1  | 0.20 |
| 20 (¾")    | 20 | 80  | 50   | 2 | 1  | 0.33 |
| 25 (1")    | 25 | 90  | 65   | 2 | 1  | 0.58 |
| 32 (1¼")   | 32 | 106 | 69   | 2 | 1  | 0.75 |
| 40 (1½")   | 40 | 119 | 79   | 2 | 1  | 1.05 |
| 50 (2")    | 50 | 140 | 94.5 | 2 | 1  | 1.57 |
| 65 (2½")   | 61 | 167 | 117  | 2 | 1  | 2.99 |
| 80 (3")    | 75 | 198 | 137  | 2 | 1  | 4.74 |

#### APPLICATIONS

Challenger Valves and Actuators are the **"Right Choice for Valves and Actuation"** when quality matters.

Servicing industries such as : Water & Waste Water, Mining, Desalination, Pumping, Industrial Processing, Irrigation, Materials Han-