

STAINLESS STEEL GATE VALVE HANDWHEEL OPERATOR 15 - 50MM MODEL - SS2029

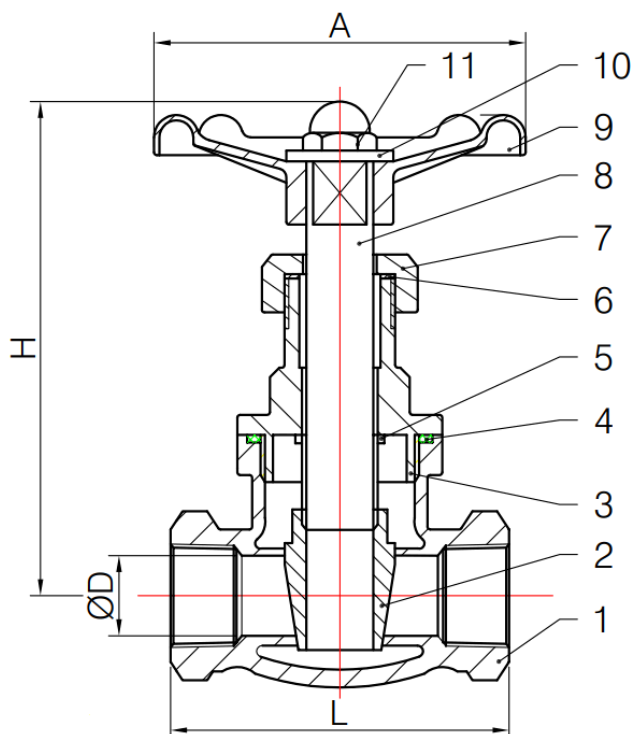

FEATURES AND BENEFITS

- For Industrial, Chemical & General Applications
- 316 S/S Construction
- Threaded BSPT Ends
- Non Rising Stem
- Investment Cast Body
- Pressure Rating: 200PSI WOG
- Working Temperature: -20°C~200°C
- Testing to API598
- Designed according to AEN12266



NO.	PART NAME	MATERIAL
1	Body	ASTM A351-CF8M
2	Disc	SS316
3	Bonnet	ASTM A351-CF8M
4	Seal	PTFE
5	Seal	PTFE
6	Gland	PTFE
7	Nut	ASTM A351-CF8M
8	Stem	SS316
9	Handle Wheel	Iron Casting
10	Gasket	SS304
11	Nut	SS304

DIMENSIONS					
DN	ØD	L	A	H	Kg
15 (½")	14	53	66	95	0.4
20 (¾")	19	57	72	95	0.52
25 (1")	24	64	78	105	0.69
32 (1¼")	30	72	97	125	1.07
40 (1½")	38	76	97	135	1.36
50 (2")	47	88	107	155	2.08

APPLICATIONS

Challenger Valves and Actuators are the **"Right Choice for Valves and Actuation"** when quality matters.

Servicing industries such as : Water & Waste Water, Mining, Desalination, Pumping, Industrial Processing, Irrigation, Materials Handling and Chemical Services.