

STAINLESS STEEL 3 PIECE BALL VALVE LEVER HANDLE 8 - 100MM MODEL - SS2013N

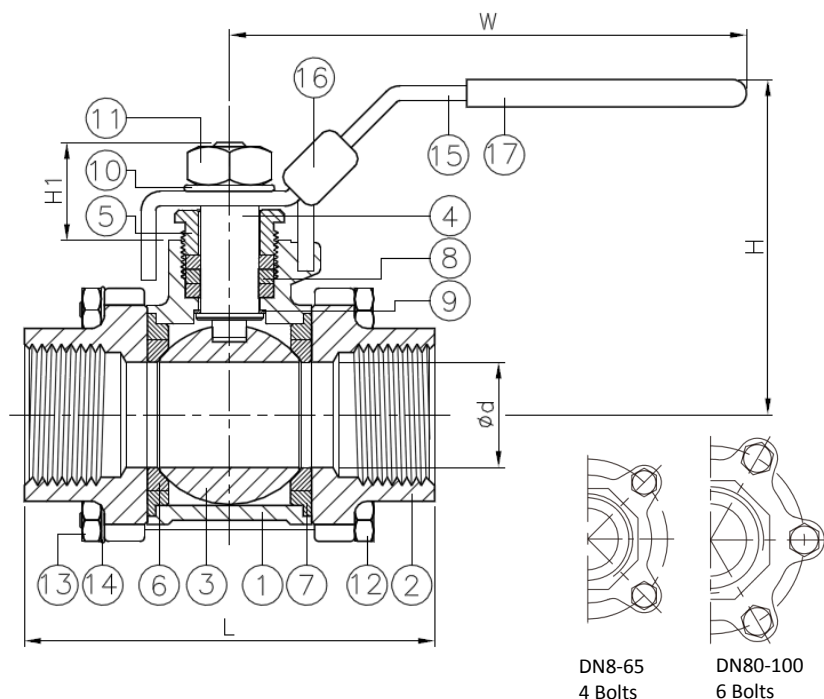

FEATURES AND BENEFITS

- For Industrial, Chemical & General Applications
- 3 Piece 316 S/S Swing Out Design (allow for inline maintenance)
- Threaded BSPT Ends
- Full Bore
- Lockable Lever Handle
- Blowout Proof Stem
- Investment Cast Body
- Pressure Rating:1000PSI
- Working Temperature: -20°C~200°C
- Replacement Seal Kits available



NO.	PART NAME	MATERIAL
1	Body	ASTM A351-CF8M
2	Cap	ASTM A351-CF8M
3	Ball	ASTM A351-CF8M
4	Stem	ASTM A276-316
5	Gland Nut	AISI 304
6	Seat	CTFE
7	Seal	CTFE
8	Packing	CTFE
9	Thrust Washer	CTFE
10	Spring Washer	AISI 304
11	Stem Nut	AISI 304
12	Bolt	AISI 304
13	Nut	AISI 304
14	Spring Washer	AISI 304
15	Handle	Stainless Steel
16	Locking Device	AISI 304
17	Handle Sleeve	PVC

APPLICATIONS

Challenger Valves and Actuators are the **“Right Choice for Valves and Actuation”** when quality matters.

Servicing industries such as : Water & Waste Water, Mining, De-salination, Pumping, Industrial Processing, Irrigation, Materials Handling and Chemical Services.

DIMENSIONS							
DN	d	L	H	H1	W	(Kg)	(Cv)
8	11.6	65	58.5	18	100	0.4	22
10	12.5	65	58.5	18	100	0.4	25
15	15	65	62	18.5	100	0.5	37
20	20	75	62	22.5	125	0.7	68
25	25	85	77	25	149	1	109
32	32	101	82	26	149	1.6	185
40	38	112	100	30	190	2.5	268
50	50	130	108	30	190	3.5	486
65	63	162	137	40	250	6.7	791
80	76	188	145	40	250	9.5	1150
100	96	224	179	54	323	19.1	1892