

RESILIENT SEAT BUTTERFLY VALVE LUGGED DN50 - DN200 MODEL: BFLN



FEATURES AND BENEFITS

- Designed and tested in accordance with AS4617 - Manually Operated Gas Valves
- AS4617 Australian Gas Association (AGA) Certified product: Licence No: AGA 8961 G
- Bi – directional bubble tight sealing.
- Vulcanised seat to the body ensures minimal seat deformation when compressed between flanges ensure low operation torques.
- High strength one piece through shaft secured by precision taper pins provides a strong and reliable disc to stem connection.
- Blow-Out proof stem ensures operator safety and eliminates OH&S issues.
- Heavy duty shaft bushing ensures disc alignment & absorbs side thrusts, reducing valve wear whilst prolonging valve life.
- Suitable for high repetition applications.
- Precision disc machining ensures mirror image of seat profile enhancing low torque operation & reduced liner wear.
- Stem seal connection is ensured with moulded double “O” rings, as well as an additional upper stem seal to provide greater design integrity.
- Robust, extended neck allows easy installation of insulation and ensures bearing integrity.
- Flange seal connection is ensured with moulded double “O” rings seals eliminating the requirement for flange gaskets.
- Lockable lever handle to prevent tampering.



TECHNICAL SPECIFICATION

- Construction:** Lugged Concentric Seal On Body Butterfly Valve
- Size:** 50mm - 200mm
- Pressure Rating:** 1050kPa
- Face to Face:** ISO5752 Series 20/AS4795.1
- Flange Drilling:** AS4087 PN16 (Table D)
AS2129 Table E
ANSI B16.5 #150
- Coatings:** Fusion Bonded Epoxy AS4158
AKZO Nobel R4-ES HJF01R
- Temperature Range:** Nitrile -10°C to 80°C
- Pressure Testing:** AS4617/AS4795.1
- Negative Pressure:** 0.1MPa (vacuum)

APPLICATIONS

Challenger Valves and Actuators are the **“Right Choice for Valves and Actuation”** when quality matters.

Servicing industries such as:
Water & Waste Water, Mining, Gas, Desalination, Pumping,
Industrial Processing, Irrigation, Materials Handling and
Chemical Services.

RESILIENT SEAT BUTTERFLY VALVE
LUGGED DN50 - DN200
MODEL: BFLN



TECHNICAL: DN50 - DN200

TECHNICAL : VALVE DETAILS

ITEM	COMPONENT	MATERIAL	GRADE	ITEM	COMPONENT	MATERIAL	GRADE
1	Plug	Stainless Steel	ASTM A276 - 304	10	Hex Bolt	Stainless Steel	ASTM A276 - 316
2	Sealing Gasket	PTFE		11	Flat Washer	Stainless Steel	ASTM A276 - 316
3	Body and Vulcanized Seat	Ductile Iron Rubber	AS1831 - 450-10 Nitrile	12	Spring Washer	Stainless Steel	ASTM A276 - 316
4	Bushing	PTFE Steel Lined	PTFE / ASTM A276 - 316	13	Hex Nut	Stainless Steel	ASTM A276 - 316
5	Disc	Stainless Steel	ASTM A351 - CF8M	14	Notch Plate	Stainless Steel	ASTM A276 - 304
6	Stem	Stainless Steel	ASTM A276 - 431	15	Hex Bolt	Stainless Steel	ASTM A276 - 316
7	Taper Pin	Stainless Steel	ASTM A276 - 316	16	Lever	Ductile Iron	AS1831-450-10
8	Y-Ring	Rubber	Nitrile				
9	Sealing Sleeve	Stainless Steel	ASTM A276 - 304				

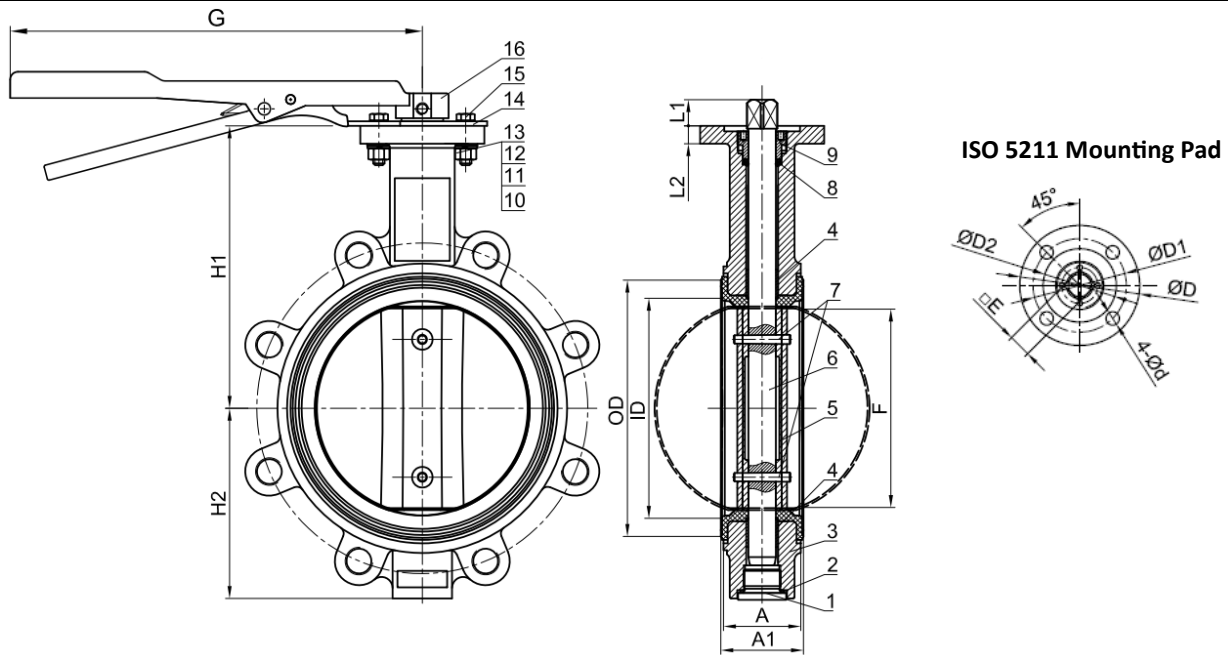

DIMENSIONS AND WEIGHTS

Size	A	A1	H1	H2	L1	L2	ØD	OD	ID	ØD1	ØD2	4-Ød	E	F	G	PCD			Compatible Flanges			Weight KG
																Table D&E	ANSI# 150	Table D	Table E	ANSI#150		
50	43	47	143	72	14	13	65	71	56	50	35	4-7	11	23.8	266	114	121	4-M16	4-M16	4-UNC 5/8	4	
65	46	50	156	78	14	13	65	86	68	50	35	4-7	11	40.4	266	127	140	4-M16	4-M16	4-UNC 5/8	4.5	
80	46	50	162	95	14	13	65	102	82	50	35	4-7	11	60.7	266	146	152	4-M16	4-M16	4-UNC 5/8	5	
100	52	56	177	108	18	13	90	130	108	70	55	4-10	14	87.7	266	178	191	4-M16	8-M16	8-UNC 5/8	8	
125	56	60	190	123	18	13	90	155	127	70	55	4-10	14	107.6	266	210	216	8-M16	8-M16	8-UNC 3/4	11	
150	56	60	205	117	18	13	90	186	160	70	55	4-10	17	143.8	328	235	241	8-M16	8-M20	8-UNC 3/4	12.5	
200	60	66	236	168	25	13	125	239	207	102	70	4-12	17	191.5	386	292	299	8-M16	8-M20	8-UNC 3/4	21	

HOW TO ORDER

Series	Design	Seat	Disc & Stem	Connection	Rating	Size	Actuator
BF	L	N	E	E	5	0100	H
Example: DN100 BF Lugged Butterfly Valve, Nitrile Seat, SS Trim, Lugged AS2129 Table E, 1050kPa with Lever Handle							
Series				Connection		Size	
BF = AS4795.1 Certified Seal on Body Butterfly Valve				E = AS2129 Table E		0050 = 2" (50mm) 0125 = 5" (125mm)	
Design				Rating		Actuator	
L = Lugged Construction				5 = 1050kPa		H = Lever Handle	
Seat				Disc & Stem			
N = Nitrile (NBR)				E = CF8M Stainless Steel Disc & 431 Stainless Steel Stem			