

VALVE POSITION MONITOR STAINLESS STEEL SWITCH BOX MODEL: APL910N



FEATURES AND BENEFITS

- Stainless Steel 304 Switchbox to IP67 fitted with 2 x SPDT switches for indication of fully open and fully closed positions.
- Solid and compact design with high visibility beacon indicator.
- Captive cover bolts are safely retained during installation and maintenance.
- The spring loaded splined cams are easily adjustable with no tools required.
- Dual cable entries are provided.
- Permanent laser marking on the nameplate.
- The switchbox is mounted to the actuator using a NAMUR standard stainless steel mounting bracket.



BRACKET OPTIONS

- Type S: 80 x 30 (H:20, 30), Suits HP050 to HP125.
- Type O: As above and 130 x 30 (H:30, 50), Suits HP145 to HP212.
Consult Factory for HP035 Actuator.

DESIGN CONSTRUCTION

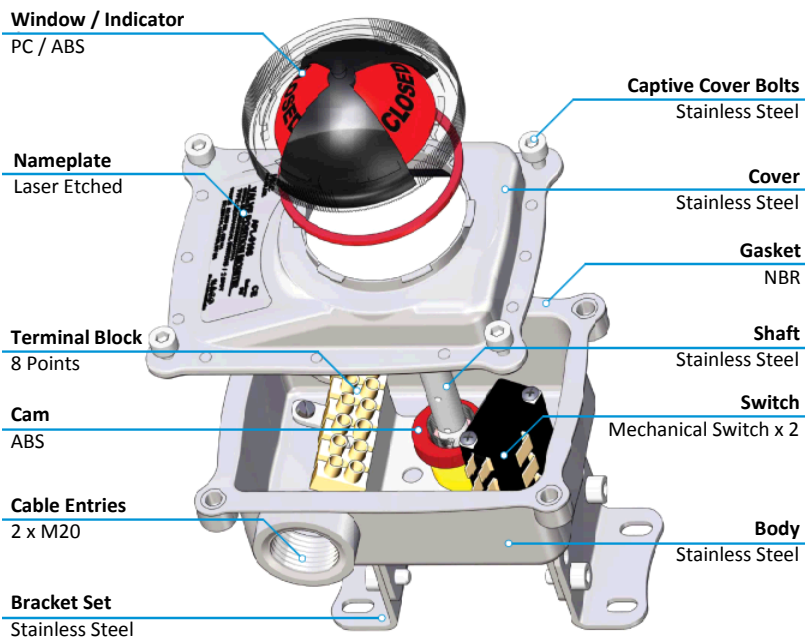

TECHNICAL SPECIFICATION

- **Enclosure:** Weatherproof IP67
- **Cable Entries:** Two M20
- **Ambient Temperature:** -50°C - 80°C
- **Terminal Strips:** 8 points (0.08-2.5mm²)
- **Position Indicator:** 0-90°
(90° turn free join close: red & open: yellow)
- **Switches:** Mechanical Switch x 2
- **Operating Frequency:**
600 per minute max (Mechanically)
60 per minute max (Electrical)
- **Contact Arrangement:**
250V AC/16A
250V DC/0.3A
125V DC/0.6A
30V DC/10A

APPLICATIONS

Challenger Valves and Actuators are the **“Right Choice for Valves and Actuation”** when quality matters.

Servicing industries such as : Water & Waste Water, Mining, Desalination, Pumping, Industrial Processing, Irrigation, Materials Handling and Chemical Services.

VALVE POSITION MONITOR STAINLESS STEEL SWITCH BOX MODEL: APL910N



DIMENSIONS [MM]

TYPE S: 80 x 30 (H: 20, 30)

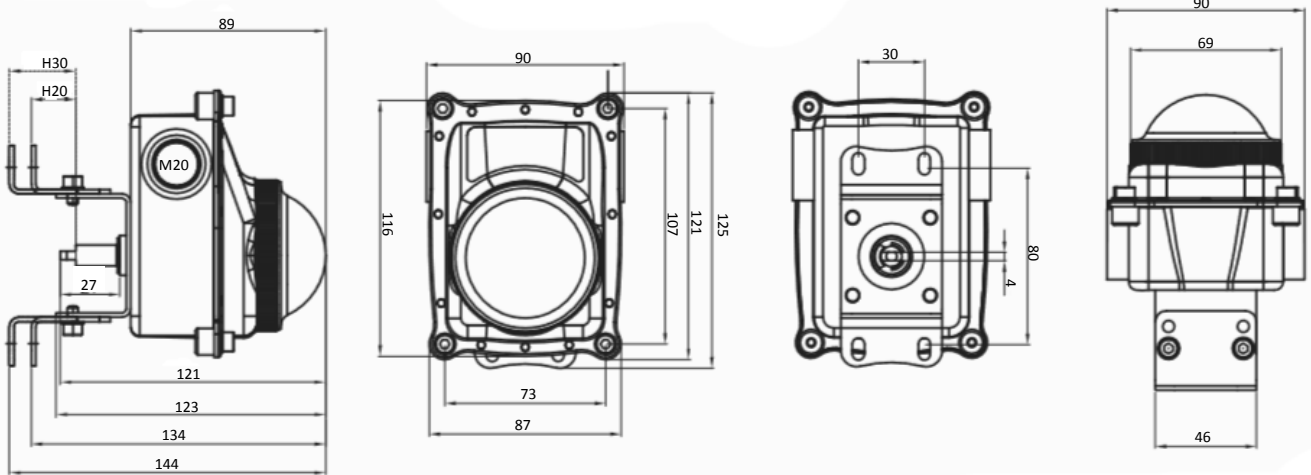

TYPE O: 80 x 30 (H: 20, 30) & 130 x 30 (H: 30, 50)

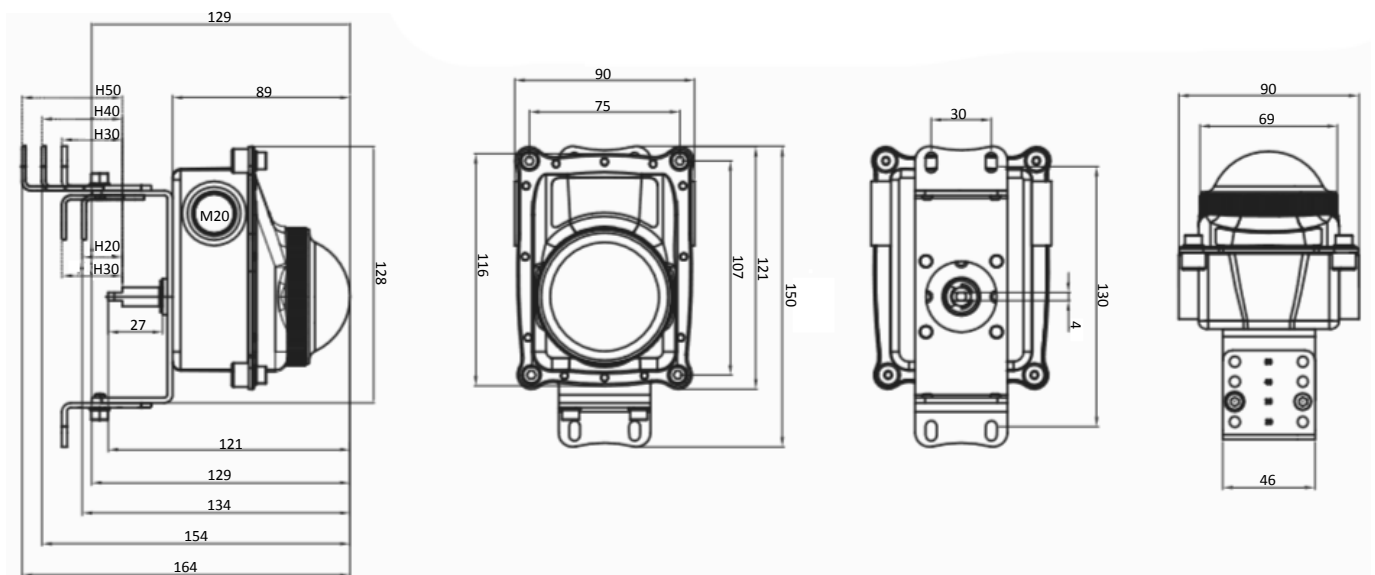

WIRING DIAGRAM

MECHANICAL SWITCHES

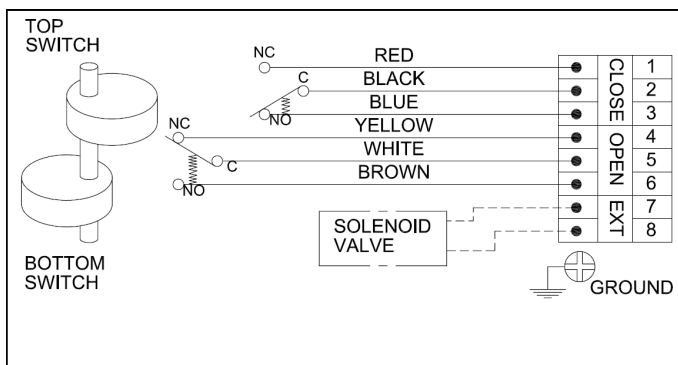

ADJUSTMENTS

Adjustment Mechanical Switch

1. Isolate Electrical Supply.
2. Unscrew captive bolts.
3. Remove the top cover .
4. You will find two coloured quick set cams (1) & (2), one cam for each limit switch
5. Gently press down and rotate each spring loaded cam, against the mechanical switch lever until the desired contact is made and release. The cam is now set in the desired position.