



Sciaire Storm HD110

INSTRUCTION MANUAL



Need Help?
0300 373 0739
9 AM – 5 PM, Monday – Friday

dhlifelabs.co.uk



Dernier & Hamlyn Products Ltd.
201 Hollymoor Way, Rubery,
Birmingham B31 5HE,
United Kingdom

*The Sciaire Storm uses PlasmaShield™ Technology.

**This symbol on the product or on its packaging indicates that the product must not be disposed of with normal household waste. Instead, it is your responsibility to dispose of your waste equipment by arranging to return it to a designated collection point for the recycling of waste electrical and electronic equipment. By separating and recycling your waste equipment at the time of disposal you will help to conserve natural resources and ensure that the equipment is recycled in a manner that protects human health and the environment. For more information about how to recycle your DH Lifelabs supplied products for recycling, please contact our Customer Services Department on 0300 373 0739 or visit <https://dhlifelabs.co.uk>.

Sciaire Storm HD110

Sciaire Storm is an advanced automatic air purifier designed for public washrooms, in various settings such as shops, restaurants, offices, and homes. It combines bi-polar air ionization technology and HEPA filtration to deliver rapid and effective air purification. The device has two key modes, a hand drying mode for immediate individual use and an air purification mode after use to clean the environment.

Table of Contents

Safety Instructions	1
Device Overview	3
Device Summary	4
Device Specifications	5
Dimensions	5
Before Placement and Installation	4
Installation	8
Installation of 85mm Recess Kit	12
Using the Air Purifier	17
Indicator Light Key	18
Filter Replacement	19
Cleaning and Maintenance	20
Troubleshooting	21
Product Warranty	22

Your safety is important to us.

Read all safety instructions before you use the device.



WARNING! TO REDUCE THE RISK OF FIRE, ELECTRIC SHOCK OR INJURY PLEASE ADHERE TO THE FOLLOWING:

- ! This device must be installed in accordance with current local wiring and building regulations, and installed by a qualified licensed electrician.
- ! WARNING: Ensure the device is fully assembled in accordance with the instructions before use. If casing is removed or handled improperly the internal components of the device may cause harm or become permanently damaged.
- ! Use this device only in the manner intended by the manufacturer.
- ! This device complies with the maximum allowable concentration of ozone of 0.05 parts per million by volume (ppmv) in a 24 hour period.
- ! The device is intended to be permanently connected to the power supply.
- ! Ensure that the mains supply (voltage, frequency, and phase) complies with the devices rating label.
- ! This device is not intended for use by persons (including children) with reduced physical, sensory or mental capabilities, or lack of experience and knowledge, unless they have been given supervision or instruction concerning use of the device by a person responsible for their safety.
- ! The device should be provided with a fused spur, isolator switch capable of disconnecting all poles, having a contact separation of at least 3mm.
- ! The device is designed for dry, internal locations only. Do not allow the area around the device to become damp or wet.
- ! All metal parts in contact with this device MUST be earthed, including any wall covering.
- ! Always use the device with the accessories provided.
- ! Do not move the device while it's wired.
- ! Do not use the device with damaged wires. It must be replaced by a suitably qualified service engineer in order to avoid a hazard.
- ! If the device is not working properly, has received a sharp blow, has been dropped or damaged, do not use the device and contact customer services.
- ! Troubleshooting and internal maintenance must be performed by qualified service personnel.
- ! Wear gloves when inspecting and cleaning the device.
- ! Do not use any power wash equipment for cleaning on or near this device.
- ! Do not use the device for drying hair or other items.

- ! Do not obstruct air inlets or outlets. Do not cover the device while in use.
- ! Do not use the device in the following places:
 - Where the ambient temperature is below -10°C or above 40°C
 - Where the device may come into direct contact with water
 - Where the device is under direct or strong sunlight
 - Where condensation may form within the device
 - Locations where corrosive, neutral, or reductive gases are present
- ! This device is intended for indoor use only.
- ! All wiring needs to be in accordance with the current I.E.E. Regulations, or the appropriate standards of your country and MUST be installed by a suitably qualified person. Conformity and compliance is the responsibility of the installer.
- ! Make sure electricity is switched off at the main panel before installing, maintaining or cleaning this device.
- ! Ensure that the conduct and wires are long enough to connect to the backplate and the terminal block.
- ! Ensure no pipe work (gas, water, air) or electrical cables, wires or ductwork are located directly behind the drilling/mounting area.
- ! Choose a completely flat, vertical wall capable of supporting the full weight of the device.
- ! Install the device in a location where it will be easy to use and ensure that there is adequate space around the device for cleaning and maintenance.
- ! Avoid installing the device in locations where people or doors might bump into the device.
- ! If the device is installed too low, water may splash onto the device when the floor is being cleaned. (The bottom of the device must be mounted at least 15 inches/381mm above the floor). This is also required to gain access to the HEPA filter for cleaning and/or replacement.
- ! Check that the electrical supply corresponds to that shown on the rating sticker of device. Do not connect the device to any electrical supply other than that stated on the rating label of the device. Permanent damage or improper, unsafe operation of the device may result.
- ! To avoid contact with water from the user's hands, do not install the device above any electrical equipment.
- ! Do not use sealant when fixing the device to the wall. This device is not suitable for mounting onto porous wall surfaces (e.g. plaster) without a back panel, to avoid discolouring or damage to unprotected walls.
- ! Before installation, please consider the flow of traffic through the washroom. Do not place the device in an area that has high footfall. You can install the device as near to the sinks as possible to minimize water spillage onto the floor from hands. You should also consider the mounting height of the devices, and who will be using it.

Read all safety instructions in the instruction manual, and on device.

SAVE THESE INSTRUCTIONS.



Device Overview

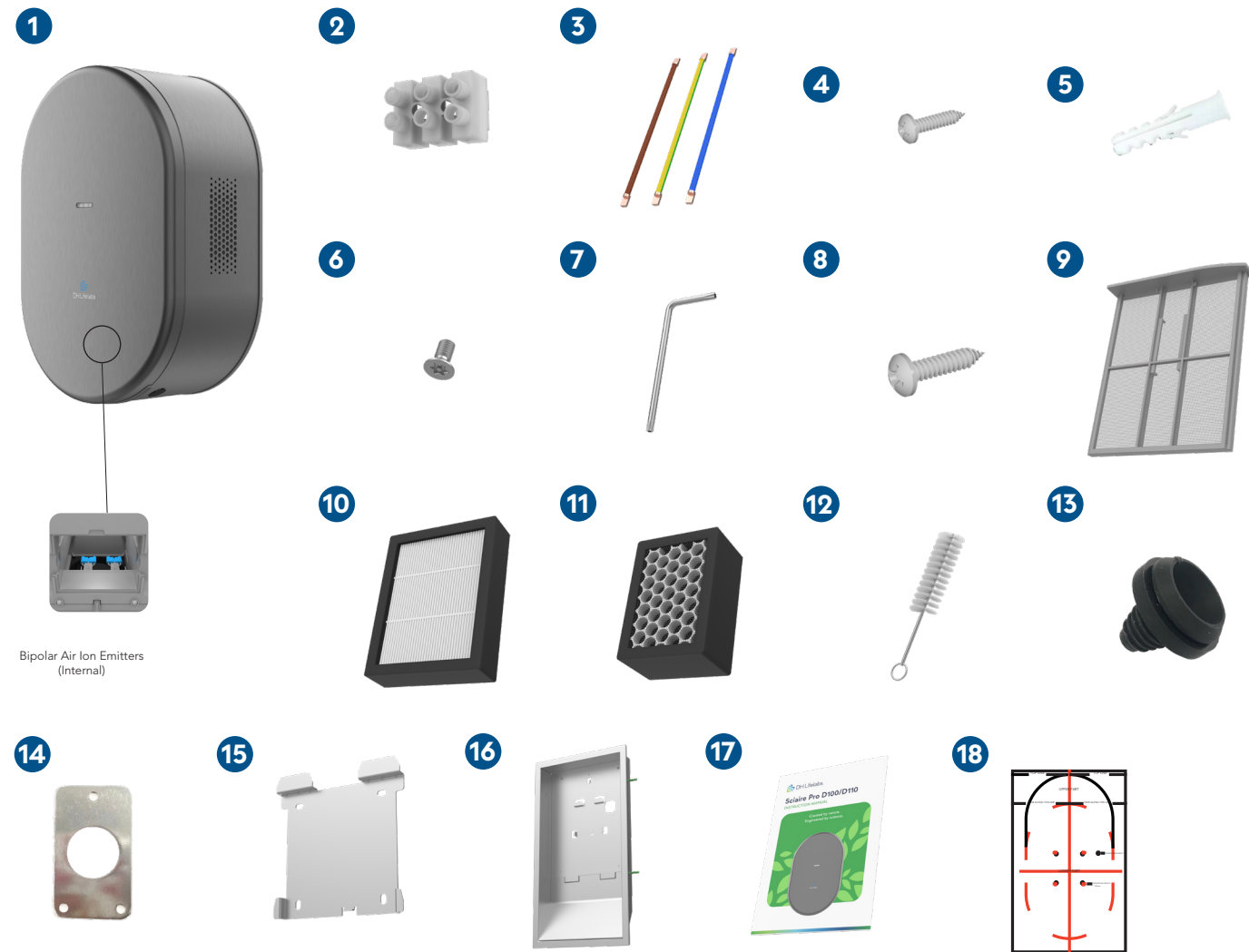

- | | |
|------------------------|---|
| 1. Air purifier | 10. HEPA filter |
| 2. Power terminal | 11. Activated carbon filter (AC filter) |
| 3. Power cables (x3) | 12. Cleaning brush |
| 4. Wood screw (x4) | 13. Grommet |
| 5. Expansion tube (x4) | 14. Small bracket |
| 6. Security screw | 15. Mounting bracket |
| 7. Security wrench | 16. 85mm recess kit (sold separately) |
| 8. Tapping screw (x3) | 17. Instruction Manual |
| 9. Pre-filter | 18. Positioning sticker |

Device Summary

Purification Mode (Activated After Using Hand Drying Mode)

1. Air comes in the right side of the device by first passing through a pre-filter, filtering large particles. Air is then passed through an activated carbon filter to absorb odours.
2. Air is then passed through Bi-Polar Air Ionizers, generating positive and negative ions, which work to actively neutralize airborne viruses and bacteria in the air.
3. The powerful motor circulation system continues to draw in ambient air, passing through the filters and distributes positive and negative ions throughout the environment, to help continuously disinfect the air.

Hand Drying Mode

1. Air is pulled into the left side of the device by first passing through a HEPA filter. The HEPA filter captures pollutants and particles down to 0.1 microns in the air.
2. The filtered air is heated and distributed at the base of the device to dry your hands using a powerful motor.

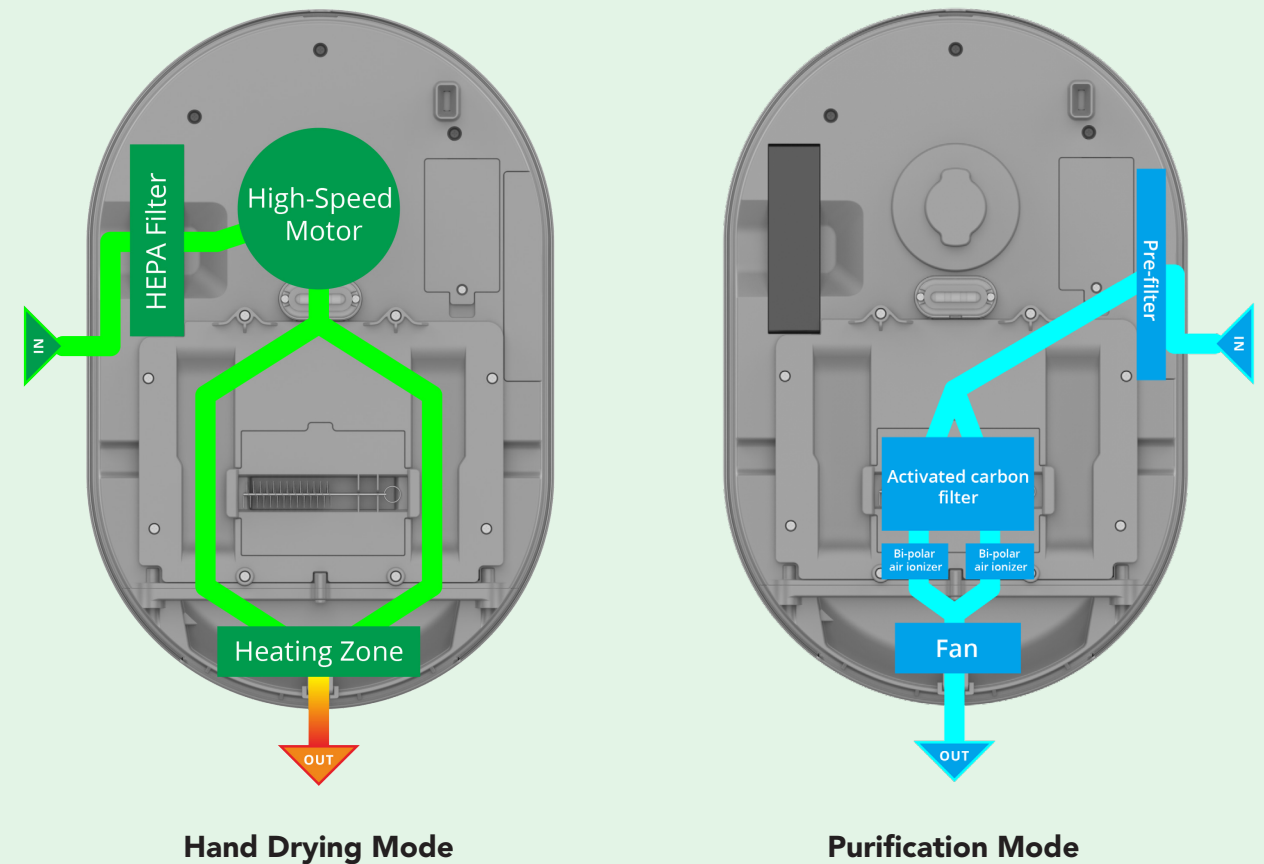

Device Specifications

Product Name	Sciaire Storm HD110
Rated Voltage	220-240V, 50/60Hz
Input Power	950-1100W
Heating Power	400W
Induction Method	IR blocking
Air Velocity	200 m/S
Protection Class	IP23
Motor	Brushed AC series motor
Dimensions	16.50 x 10.98 x 6.85 in (419 x 279 x 174 mm)
Net Weight	14.12lbs (Device)
Noise	79 dB(A)

Dimensions

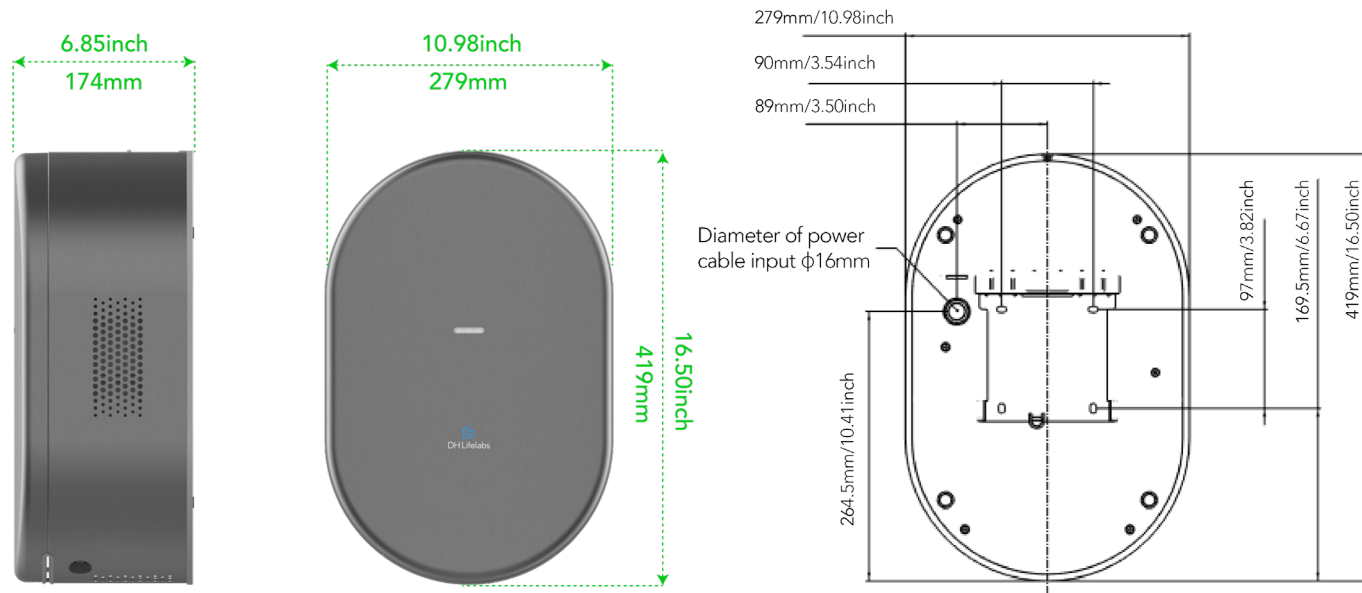

Before Placement and Installation

Before installation, please consider the traffic at various locations in the restroom. We do not recommend placing this device in front of crowded areas in the restroom. Refer to the suggested mounting heights on the next page.

- 1 DO NOT place the device too close to the door.**
- 2 DO NOT place the device too far away from the sink(s).**
- 3 DO NOT place above reflective surfaces.**
- 4 DO NOT place the device in direct sunlight.**

Efficiency Radius

Installing the device at a 4-foot distance will have a great cleaning and deodorization effect. It is still effective at an 8-foot distance. Efficacy depends on specific environmental conditions of the space, including air flow, space size and frequency of hand drying use.

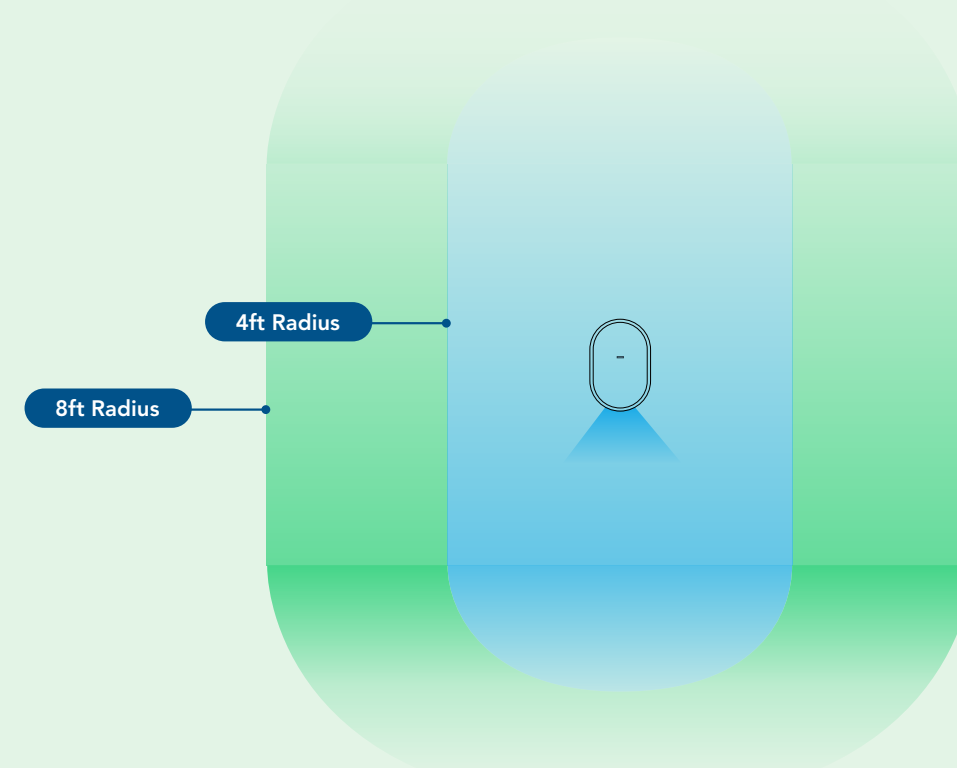

Packaging

1. Remove the device from the box. Confirm all items shown in the Product Overview are included. It is recommended to retain the packaging in case of storage or repair purposes.
2. Place the device on a cloth to avoid marking its surface, and to confirm installation location prior to setup.

Suggested Mounting Height

Users	Height (to Bottom of Device)
Men	45 Inches (1143 mm)
Women	43 Inches (1092 mm)
Teenagers	41 Inches (1041 mm)
Small Children	35 Inches (889 mm)
Accessible	37 Inches (940 mm)
Countertop	15 inches (381 mm)

Electrician may be needed for power wiring/rerouting wiring.

1. It is imperative that the location of the hole drilled for the power cable input wires matches up with the appropriate placement of the device.
2. There is a recommended height for each segment of user. The height is to be measured from the floor to the bottom of the device.
3. To mark the proper placement for the power cable input hole, refer to the placement sticker included in the packaging. Do not remove the backing to the sticker if not immediately installing device after electrical work is complete. Utilize the sticker to mark the wall for the exact location of the power input for accurate electrical wiring placement.

Installation

If installing 85mm recess kit, skip ahead to page 12.

1 Position Installation Sticker

Position the installation sticker on the intended wall based on the location of the power cable input. The power cable input may be newly installed for accurate placement of the device. Ensure the diameter of the hole for the power cable input is as displayed on the sticker.

2 Drill Mounting Holes

Drill 4 mounting holes according to the marks.

3 Insert Expansion Tubes

Tear off the lower part of the sticker along the line. Insert the expansion tubes (x4) into the mounting holes.

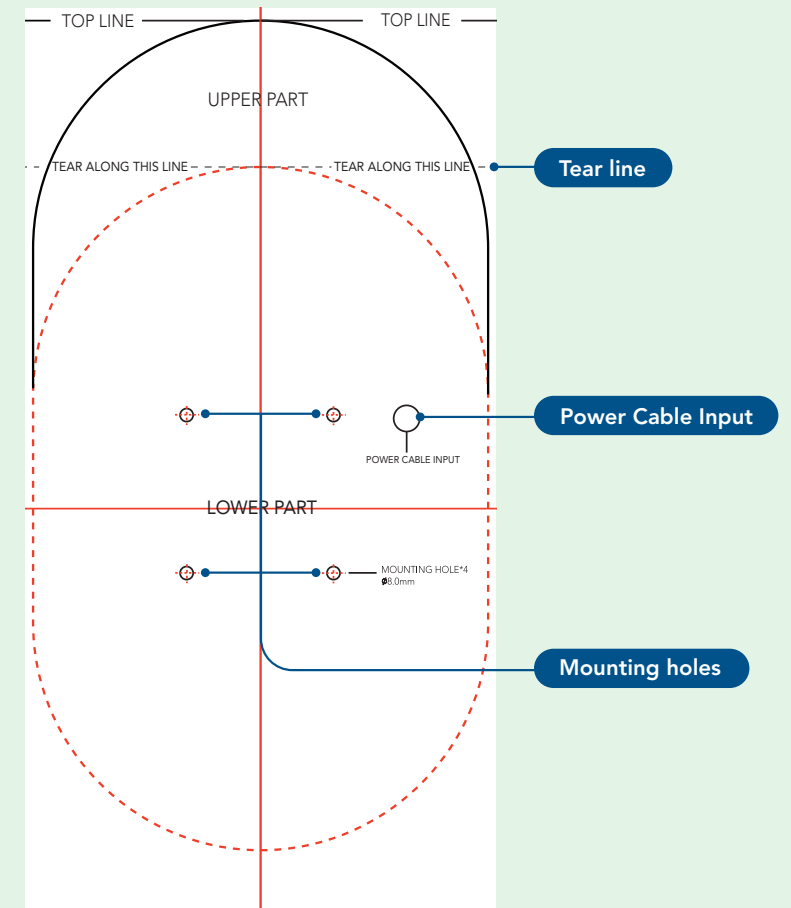
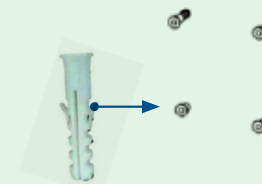
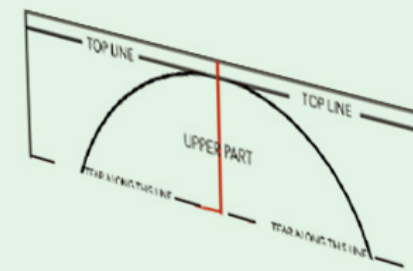

4

Align the holes of the mounting bracket and the mounting holes on the wall. Insert the wood screws to the holes. Tighten the wood screws to fix the mounting bracket to the wall.

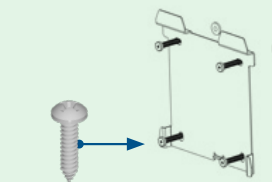
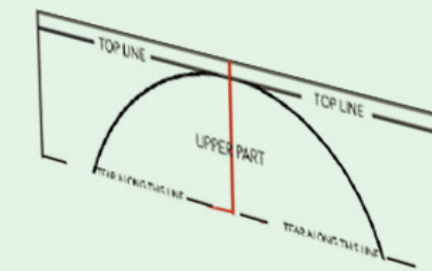

5 Remove Front Cover

Use the anti-theft wrench to loosen the anti-theft screw in the bottom part.

Security Screw

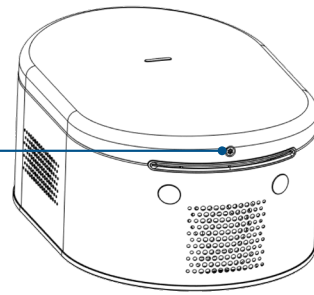

Lift the bottom up and gently push up to remove the complete cover.

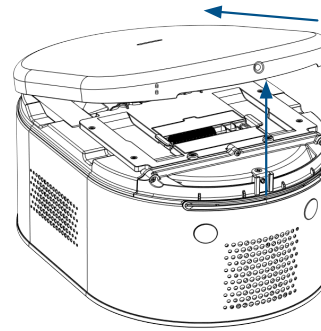

6 Remove Filters

Activated Carbon Filter

Take out the activated carbon filter and remove any protective packaging.

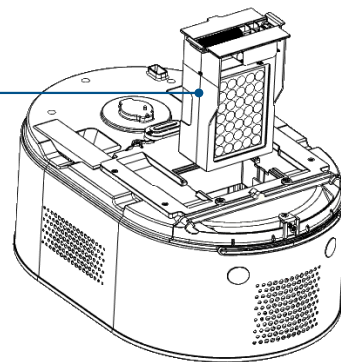

HEPA Filter

Take out the HEPA filter and remove any protective packaging.

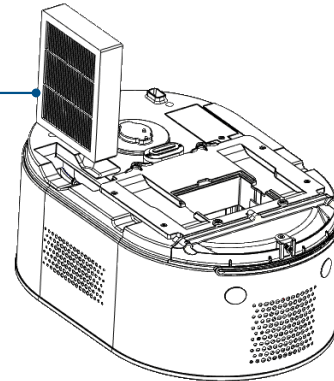

7 Remove Power Supply Cover

Power Supply Cover

Loosen the screw on the cover of the power supply unit and take off the cover.

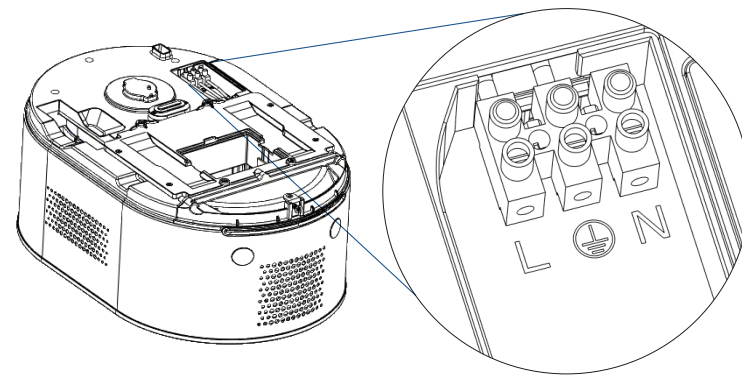
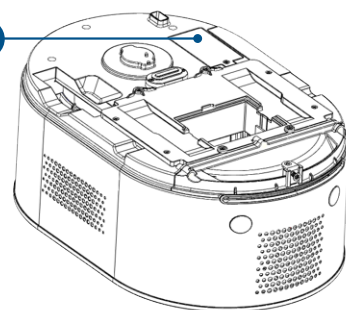

8 Install Grommet & Small Bracket

Trim the grommet to a moderate size. Install the trimmed grommet to the small bracket.

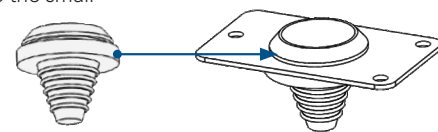

Install the protruding side of it into the power cable hole on the back of the device. Install the device with the tapping screws to fix it.

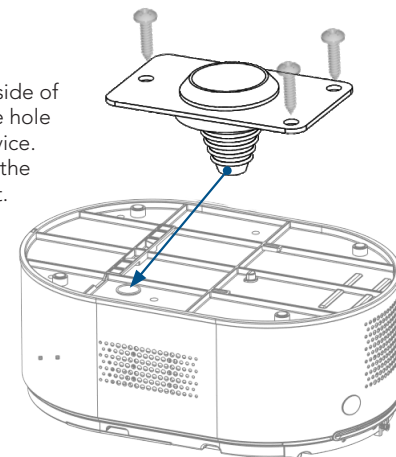

9 Pass Power Cables Through Device

Hold up the device. Pass the power cables through the hole on the back of the device.

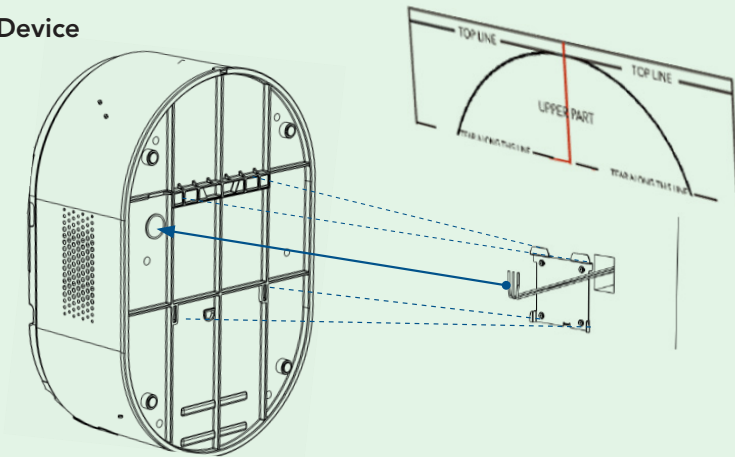

10 Mount Device to Bracket

Align the top of the device to the TOP LINE labeled on the positioning sticker. Slide the device down until the mounting slots on the back of the device snaps into the mounting bracket. Check to make sure the device is secure and does not wobble.

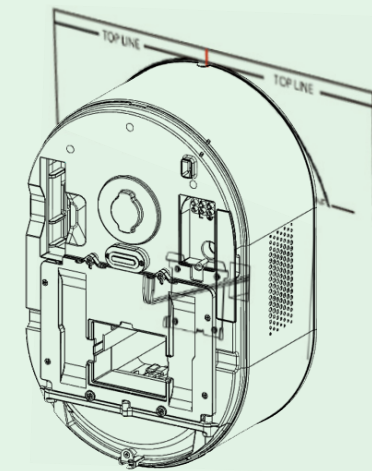

11 Connect the power cables to the terminal

Organize the power cables and connect them to the corresponding terminal ports. In order from left to right: first is the brown cable (L-Live). Secondly, it's the yellow-green cable (E-Earth). Last, the blue cable (N-Neutral).

Left: Brown cable (L-Live).

Middle: Yellow-green cable (E-Earth)

Right: Blue cable (N-Neutral).

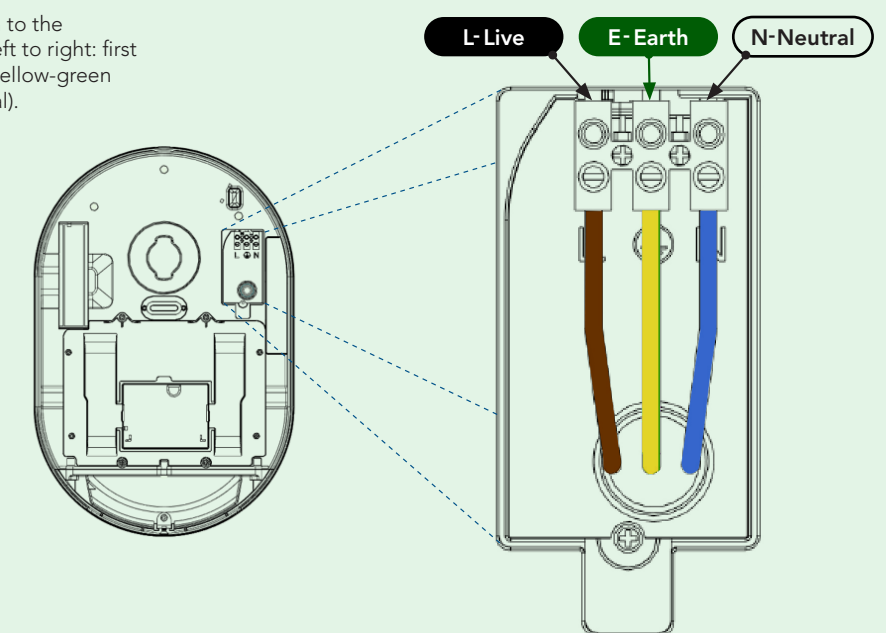

12 Install the Cover for the Power Supply

Reattach cover for the power supply device and secure it.

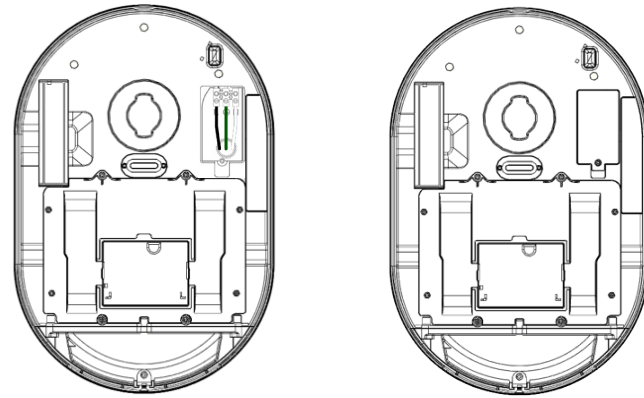

13 Install the HEPA & AC filters

Tear off the packaging of the HEPA filter and insert into the device.

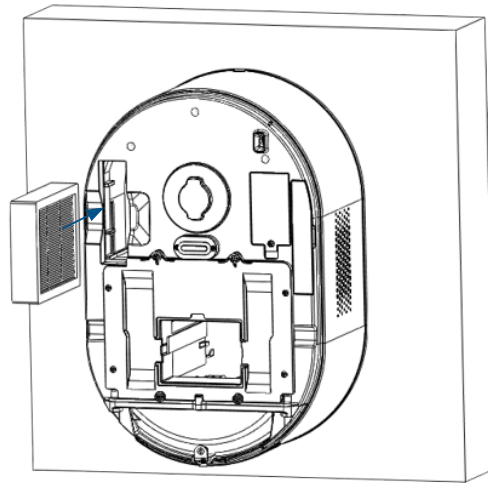

Insert AC filter into the unit box, then insert the unit box into the device.

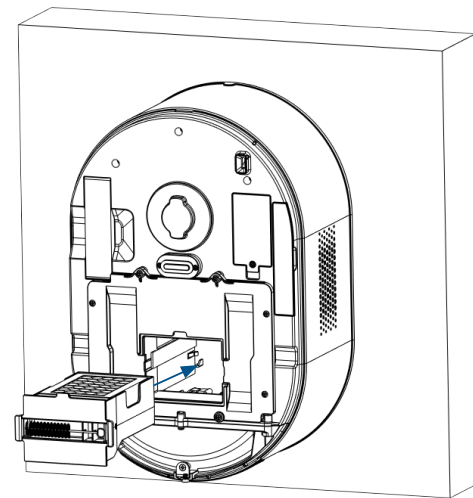
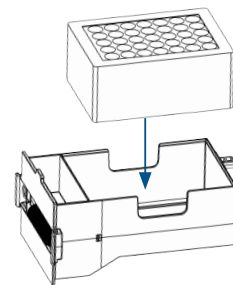

14 Resecure Front Cover

When installing the top cover, first insert the positioning piece at the end of the top cover against the positioning hole of the main unit. Install the top-end of the cover first, then snap the bottom-end until the edge of the cover coincides with the edge of the device. Screw in the anti-theft screw with the anti-theft wrench to attach the cover to the device. Once complete, tear off the upper part of the positioning sticker.

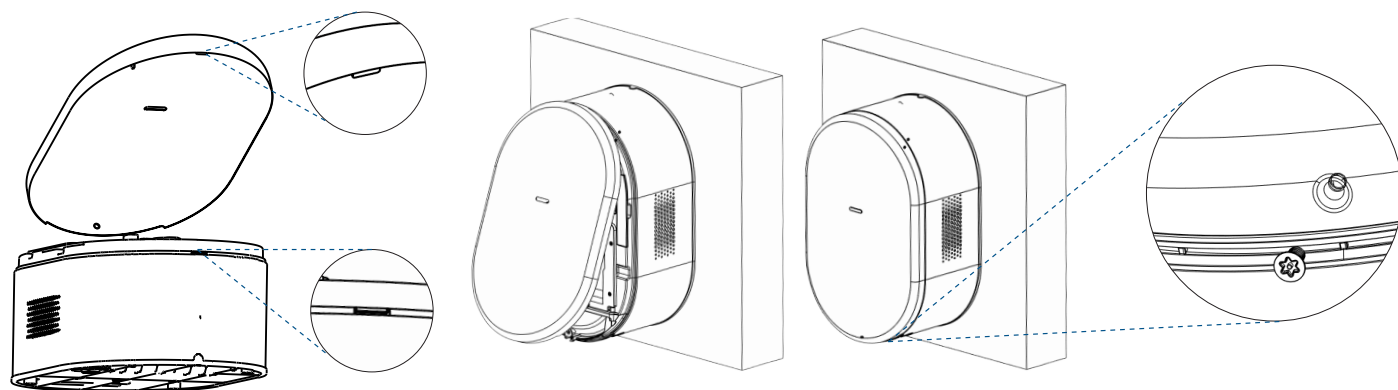

Installation of 85mm Recess Kit

The 85mm Recess Kit is sold as a separate accessory. Contact DH Lifelabs Customer Services for additional information.

Part NO.	Product Name	Model NO.	Includes
907100000	85mm recess kit for Sciare Storm HD110	HD100AC-1	85mm recess kit*1 Expansion tube*4 Wood screw*4 Anti-theft screw*2 Anti-theft wrench*1

1 Create Installation Frame

According to the installation height and power cable position, create a frame in the wall with size:

Width: 366 mm

Height: 705 mm

Depth: 100 mm

Middle: Yellow cable (E-Earth)

Right: Blue cable (N-Neutral).

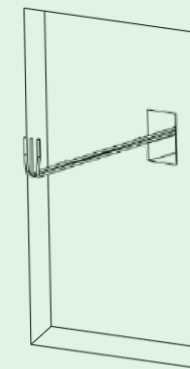

2 Drill Mounting Holes

Align the 85mm recess kit to the frame and mark hole positions on with the pencil on the wall. Drill holes on both sides according to marks.

Drill bit: ϕ 8.0mm

Hole Depth: 60mm

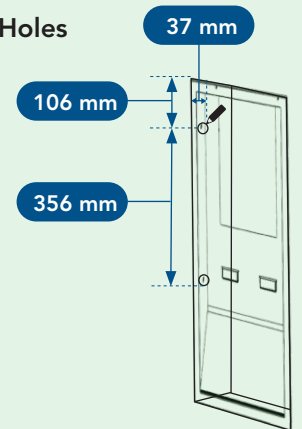

3 Mount 85mm Recess Kit

Insert 4 x expansion tubes into 4 x mounting holes.

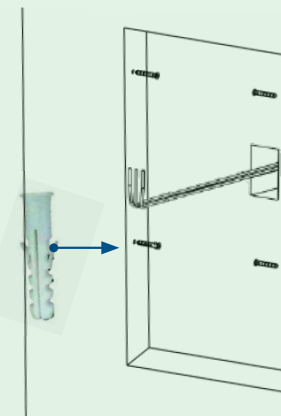

Align the 85mm recess kit to the wall and secure it with 4 x wood screws.

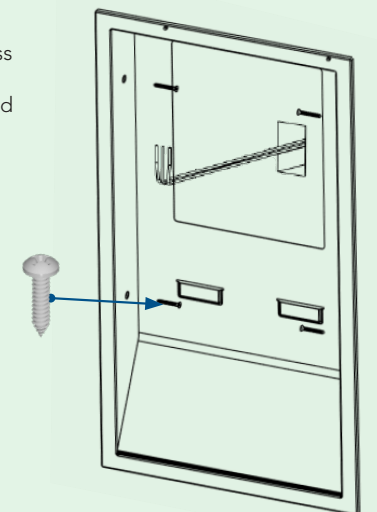

4 Remove Front Cover

Use the anti-theft wrench to loosen the anti-theft screw in the bottom part.

Security Screw

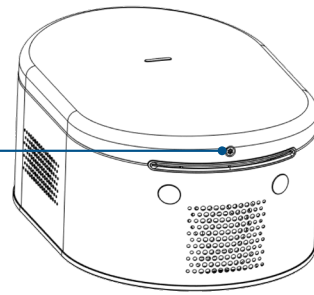

Lift the bottom up and gently push up to remove the complete cover.

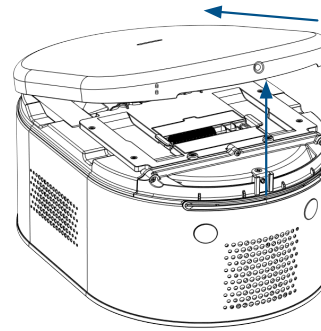

5 Remove Filters

Activated Carbon Filter

Take out the activated carbon filter and remove any protective packaging.

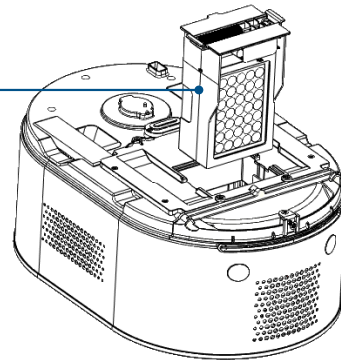

HEPA Filter

Take out the HEPA filter and remove any protective packaging.

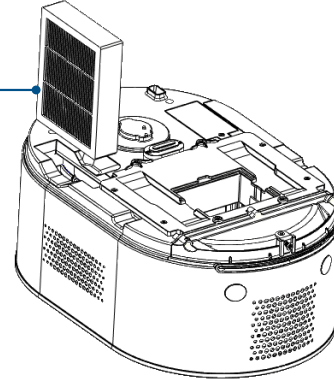

6 Install Grommet & Small Bracket

Trim the grommet to a moderate size. Install the trimmed grommet to the small bracket.

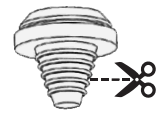

Install the protruding side of it into the power cable hole on the back of the protection bracket.

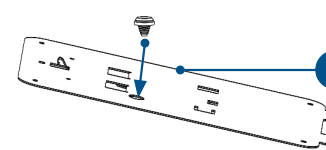

Protection Bracket

7 Attach Protection Bracket to Device

With the back of the device facing up, install the protection bracket. Snap the buckles on the protection bracket to the slots on the back of the device. Install the protection bracket with the tapping screws to fix it.

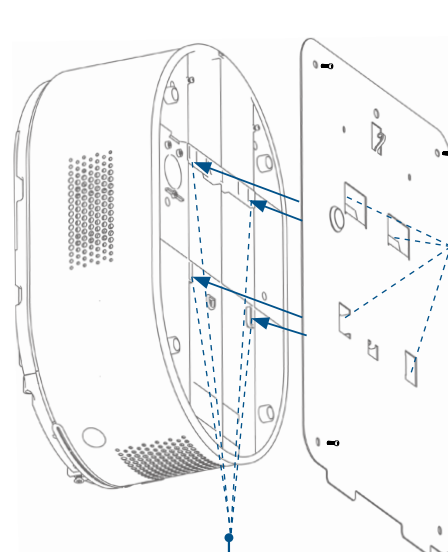

Buckles

Slots

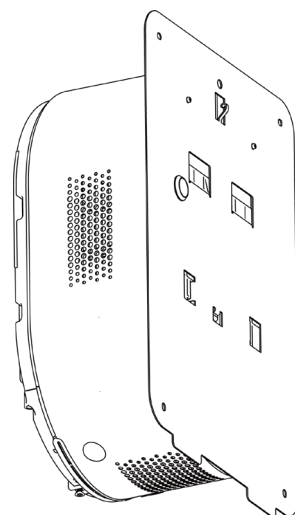

8 Install the HEPA & AC filters

Tear off the packaging of the HEPA filter and insert into the device.

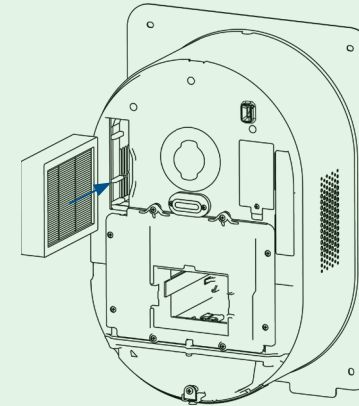

Insert AC filter into the unit box, then insert the unit box into the device.

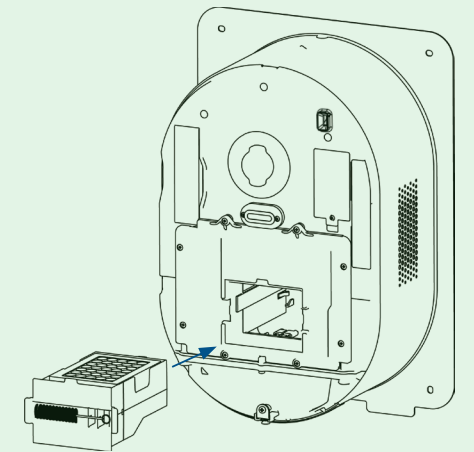
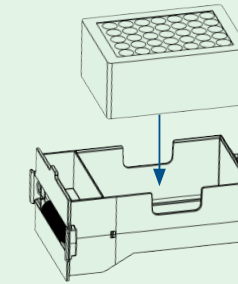

9 Remove Power Supply Cover

Power Supply Cover

Loosen the screw on the cover of the power supply unit and take off the cover.

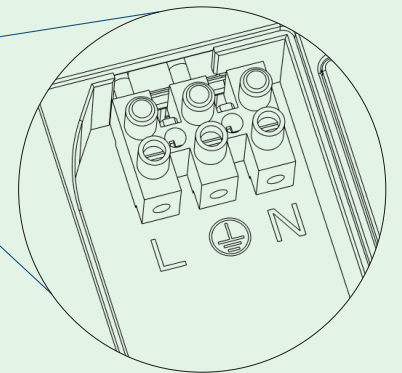
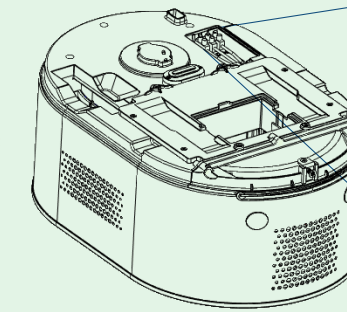
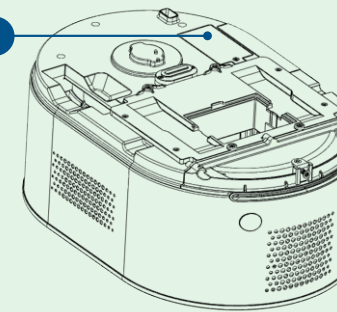

10 Secure Device to 85mm Recess Kit

Insert the bottom of the protection bracket into the slots at the bottom of the 85mm recess kit.

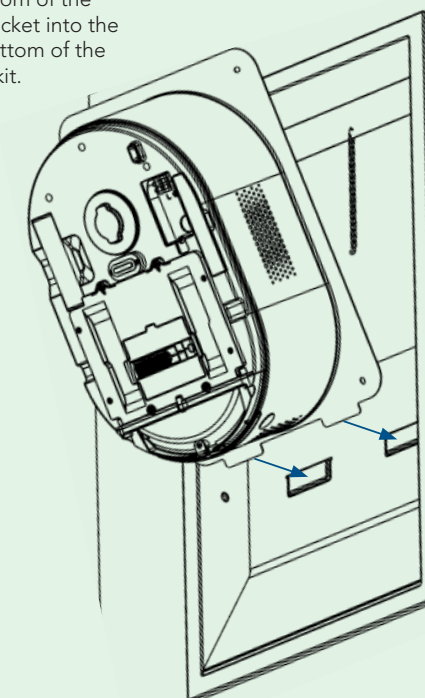

Attach the chain included with the 85mm recess kit to the top rear slot of the protection bracket of the device.

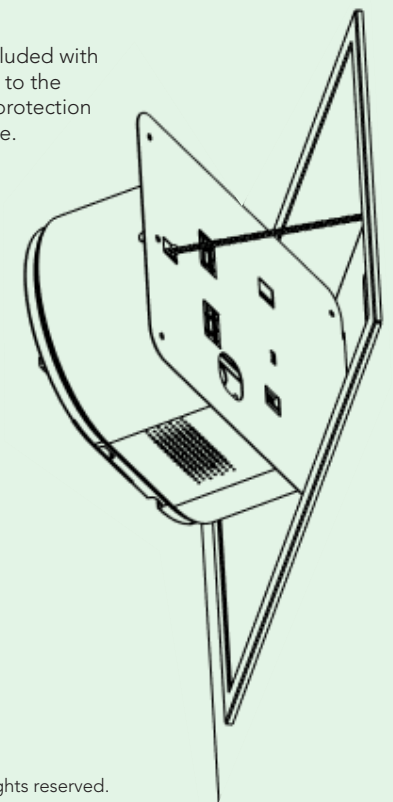

11 Connect Power Cables to the Terminal

Hands can be released to pass through the power cables through the power cable hole from the back of the device.

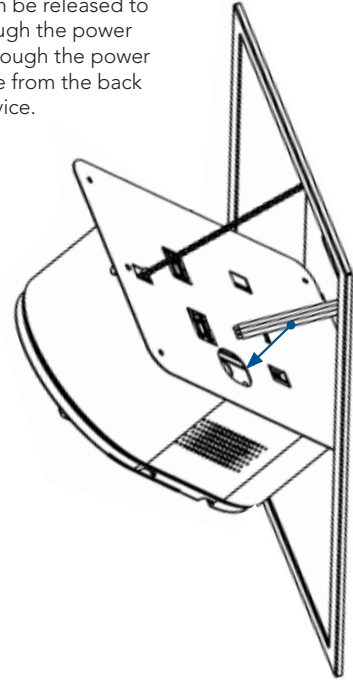

Organize the power cables and connect them to the corresponding terminal ports.

Left: Brown cable (L-Live).

Middle: Yellow-green cable (E-Earth)

Right: Blue cable (N-Neutral).

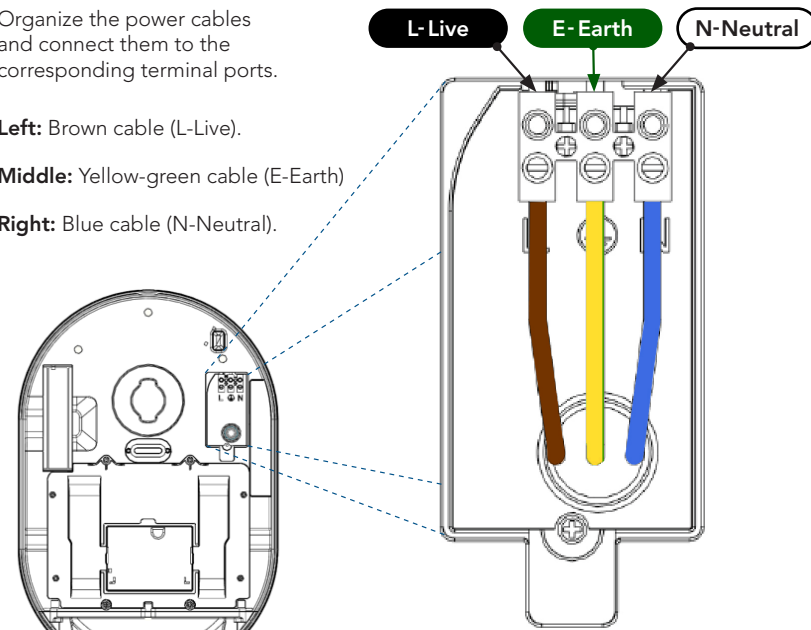

12 Attach Protection Bracket to 85mm Recess Kit

Align position of the device to straighten it.

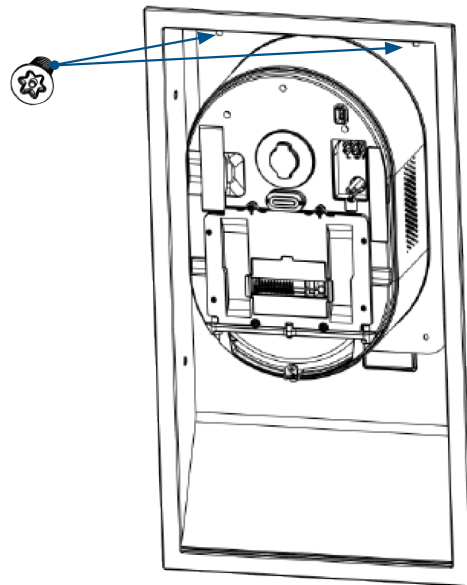

13 Install the Cover for the Power Supply

Reattach cover for the power supply unit and secure it.

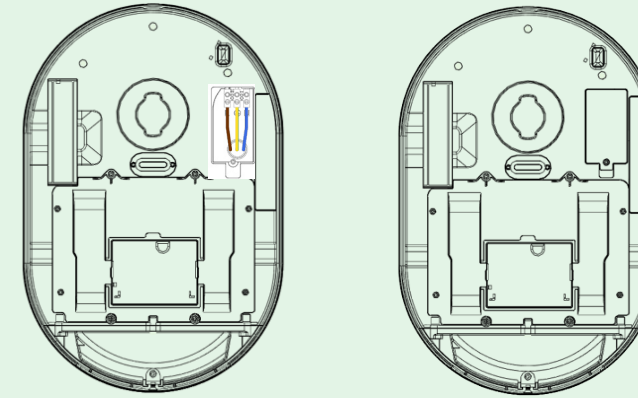

14 Resecure Front Cover

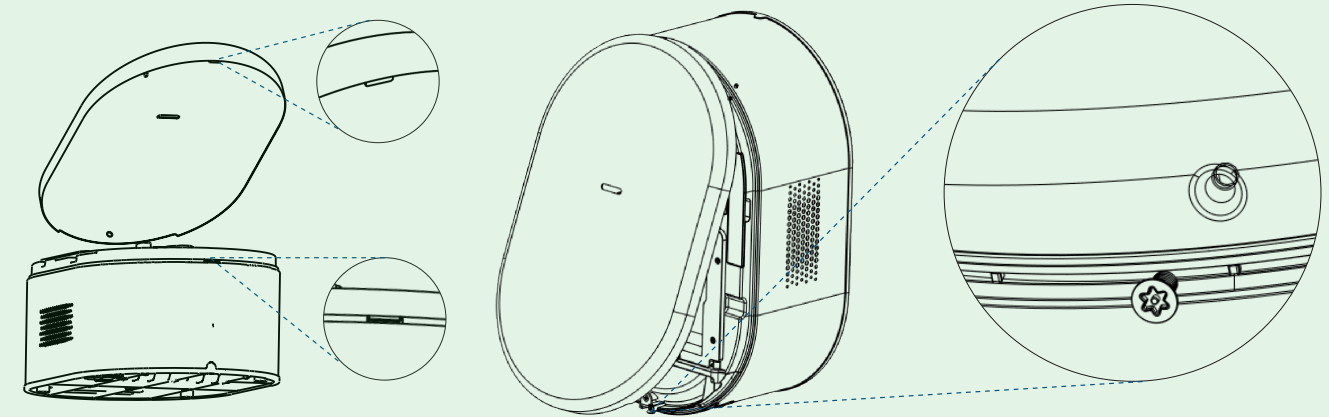

When installing the top cover, first insert the positioning piece at the end of the top cover against the positioning hole of the main unit.

Install the top end of the cover first and then snap the bottom end until the edge of the cover coincides with the edge of the device. Screw the anti-theft screw with the anti-theft wrench to fix the cover to the device.

Using the Air Purifier

1

Shake off excess water at the sink.

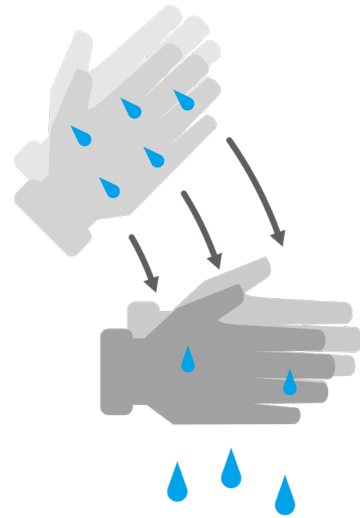

2

The device has two sensors to each side of the air output. Place hands separated and parallel to the device to trigger sensors.

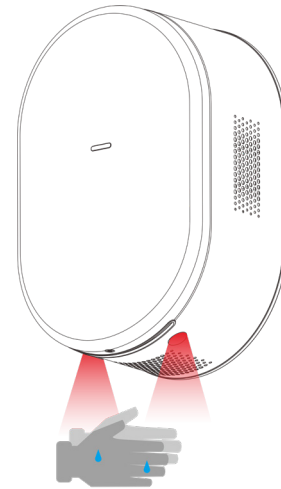

3

Move hands back and forth slightly to dry the water on the hands.

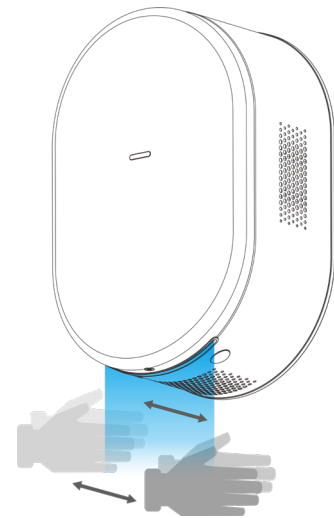

4

When the hands are dry, pull your hands out completely.

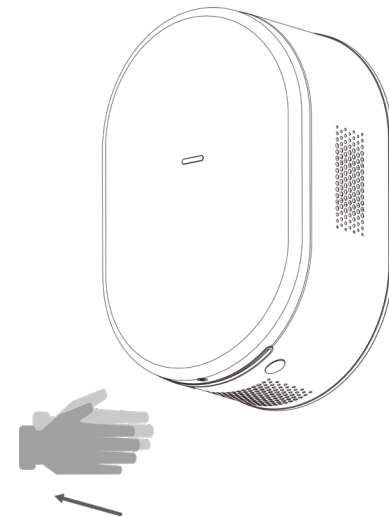



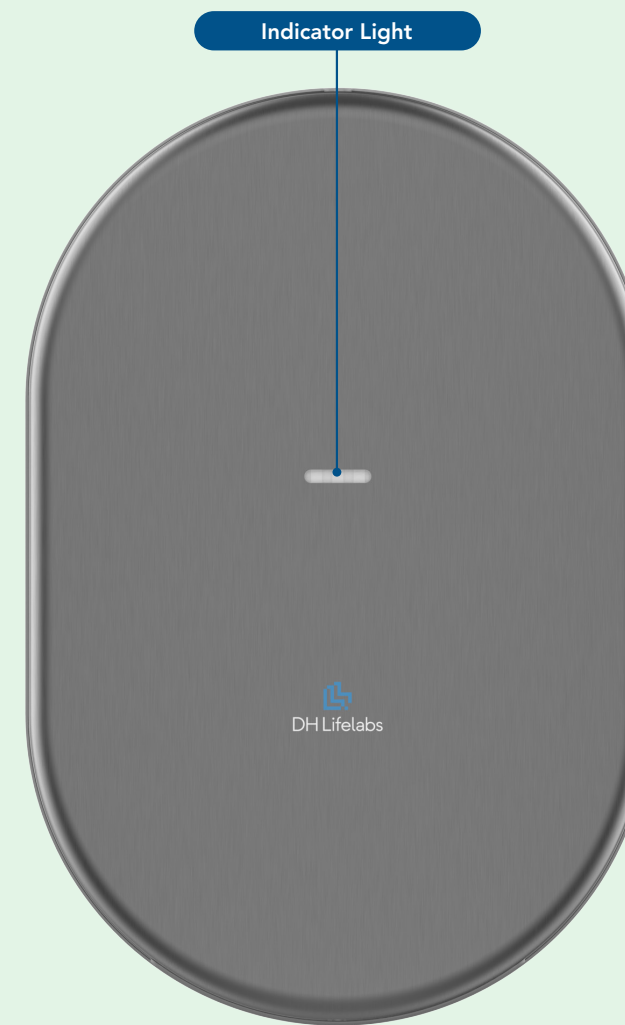

After powering on, the device needs to be triggered once to enter normal operating mode.

The maximum working time of hand drying is 30 seconds. If the device is being used for more than 30 seconds, it will stop for protection.

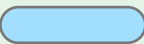
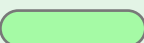
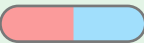
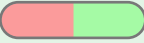
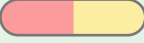
Indicator Light Key

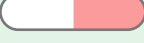

-  **Standby Mode**
Flashing blue light
-  **Purification Mode**
Solid blue light
-  **Hand Drying Mode**
Solid green light
-  **Activated Carbon (AC) Filter Replacement Reminder**
Alternating flashing red and blue light
-  **HEPA Filter Replacement Reminder**
Alternating flashing red and green light
-  **AC or HEPA Filter Not Installed**
Alternating flashing red and yellow light
-  **Device Motor Failure**
Flashing white light
-  **Purification Fan Failure**
Alternating flashing white and red light
-  **NTC Temperature Sensor Fault Alarm**
Flashing yellow light

Filter Replacement



THE DEVICE MUST BE ISOLATED FROM THE POWER SUPPLY BEFORE ANY REPLACING FILTERS

- ! Only use genuine DH Lifelabs Filters. Use of any other filters may compromise the proper operation of your device and potentially void your warranty.
- ! FILTERS ARE NOT WASHABLE. DO NOT IMMERSE IN WATER.

Activated Carbon (AC) Filter Replacement

The AC filter should be replaced every 6 months or when indicated by the alternating flashing red and blue light. This interval is only a recommendation. The filter may need to be replaced earlier or later depending on how often it's used and the environment surrounding the device.

1. Remove the security screw and open the front cover.
2. Remove the old AC filter from the unit box and dispose according to local regulations.
3. Remove protective packaging from the new AC filter and insert it into the unit box.
4. Locate the cleaning brush on the front of the unit box and use to clean the PlasmaShield emitters (see page 20) and replace brush back in the front of the unit box.
5. Install the unit box in the device.
6. Install the cover and secure with screw.

HEPA Filter Replacement

The HEPA filter should be replaced every 18 months or when indicated by the alternating flashing red and green light. This interval is only a recommendation. The filter may need to be replaced earlier or later depending on how often it's used and the environment surrounding the device.

1. Remove the security screw and open the front cover.
2. Remove the old HEPA filter and dispose according to local regulations.
3. Remove protective packaging from the new HEPA filter and insert it into the device.
4. Install the cover and secure with screw.

To purchase replacement filters please call 0300 373 0739 or email UKsales@dhlifelabs.com

HEPA Filter: Model No. DH11FT-1. Part No. 907100360.

AC Filter: Model No. DH11FT-2. Part No. 907100370.

Cleaning and Maintenance



THE DEVICE MUST BE ISOLATED FROM THE POWER SUPPLY BEFORE ANY REPLACING FILTERS

- ! CAUTION: ALWAYS WEAR SUITABLE GLOVES WHEN CLEANING.

- Remove any dirt from the sensor area.
- Use a dry cloth to clean the exterior of the device. Do not use any chemicals or cleaners.
- It is recommended that the interior of the device be inspected at least once a year and cleaned as necessary, or if performance degrades. Heavy use or an environment containing a high amount of lint, dust or other particles, requires more frequent cleaning. Particles on the air inlet, pre-filter and other internal parts of the device can reduce efficiency and shorten the lifespan of the parts.
- Use cleaning brush located on the front of the AC unit box to clean the PlasmaShield emitters. This can be done when replacing the AC filter.

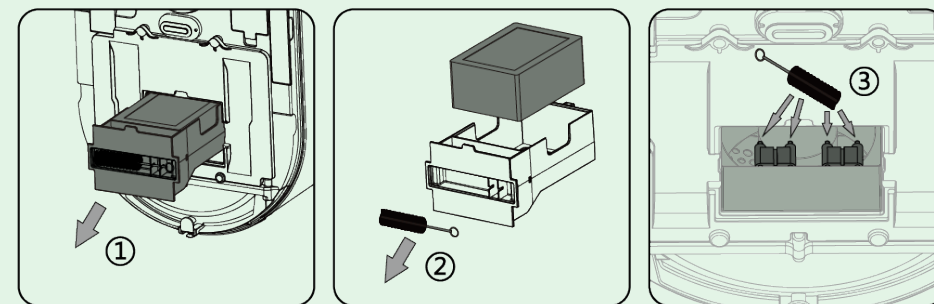

- It's recommended to clean the pre-filter with water every 3-6 months to increase efficiency.
- When the device is not used for an extended time, store it in a cool dry place. Do not store the device where it might be exposed to excess moisture or direct sunlight.
- The device may not operate effectively in very low temperatures. The device can be damaged when exposed to sub-freezing temperatures.

Troubleshooting

! Please disconnect the power supply immediately to avoid the danger of electric shock before operation.

Malfunction	Common Cause	Possible Solution
Device does not run	No electricity supply	Check main supply / cables
	Dirty infrared sensor cover	Clean the infrared sensor cover
	Installation errors	Check instruction manual for possible power cable connection mistakes
	Element open circuit or others	Contact Customer Services
Device runs continuously	Short circuit	Contact Customer Services
	Sensor faulty	Contact Customer Services
Device sometimes runs	Internal components defect	Contact Customer Services
Device runs at low speed	Worn motor	Contact Customer Services
Sparks from device	Motor breakdown	Contact Customer Services
Device cycles on and off	Internal components defect	Contact Customer Services
Abnormal noise from the device	Motor defect	Contact Customer Services
	Fan cage is bent or damaged	Contact Customer Services

Product Warranty

This 3 year limited warranty applies to repair or replacement of product found to be defective in material or workmanship. This warranty does not apply to damage resulting from commercial, abusive, unreasonable use or supplemental damage. Defects that are the result of normal wear and tear will not be considered manufacturing defects under this warranty.

DH LIFELABS IS NOT LIABLE FOR INCIDENTAL OR CONSEQUENTIAL DAMAGES OF ANY NATURE, ANY IMPLIED WARRANTY OF MERCHANTABILITY OR FITNESS FOR A PARTICULAR PURPOSE ON THIS PRODUCT IS LIMITED IN DURATION TO THE DURATION OF THIS WARRANTY.

Some jurisdictions do not allow the exclusion or limitation of incidental or consequential damages or limitations on how long an implied warranty lasts, so the above limitations or exclusions may not apply to you. This warranty gives you specific legal rights, and you also may have other rights which vary from jurisdiction to jurisdiction. This warranty applies only to the original purchaser of this product from the original date of purchase

At its option, DH Lifelabs will repair or replace this product if it is found to be defective in material or workmanship. This warranty does not cover damage resulting from any unauthorized attempts to repair or from any use not in accordance with the instruction manual. This warranty does not cover the filter except for material or workmanship defects.

