

DRAWING 1A

MODEL#	
PROJECT:	
NOTES:	
DATE:	
APPROVED BY:	
WEIGHT	
Pole:143 LBS/PC	Anchor Bolt:10.5 LBS/SET
Install Base Shield:5.06LBS/PC	Positioning Plate:0.5 LBS/PC

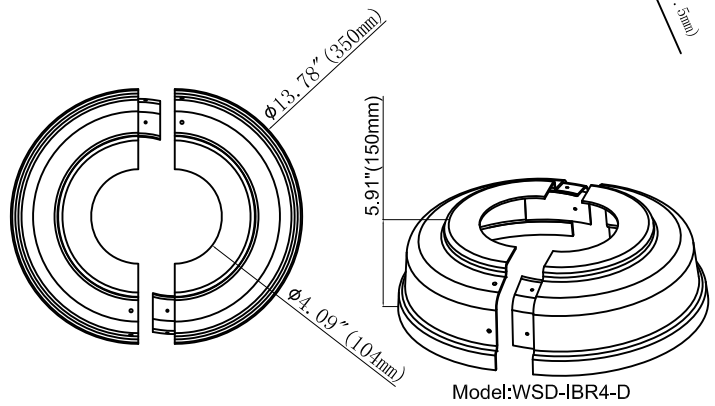
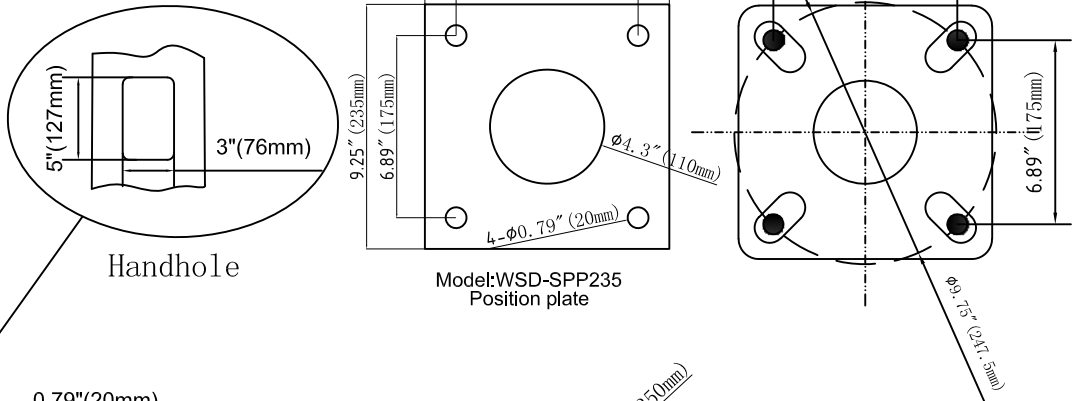
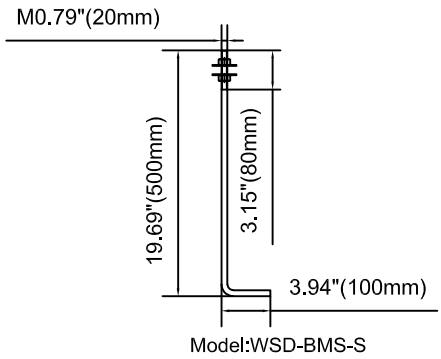
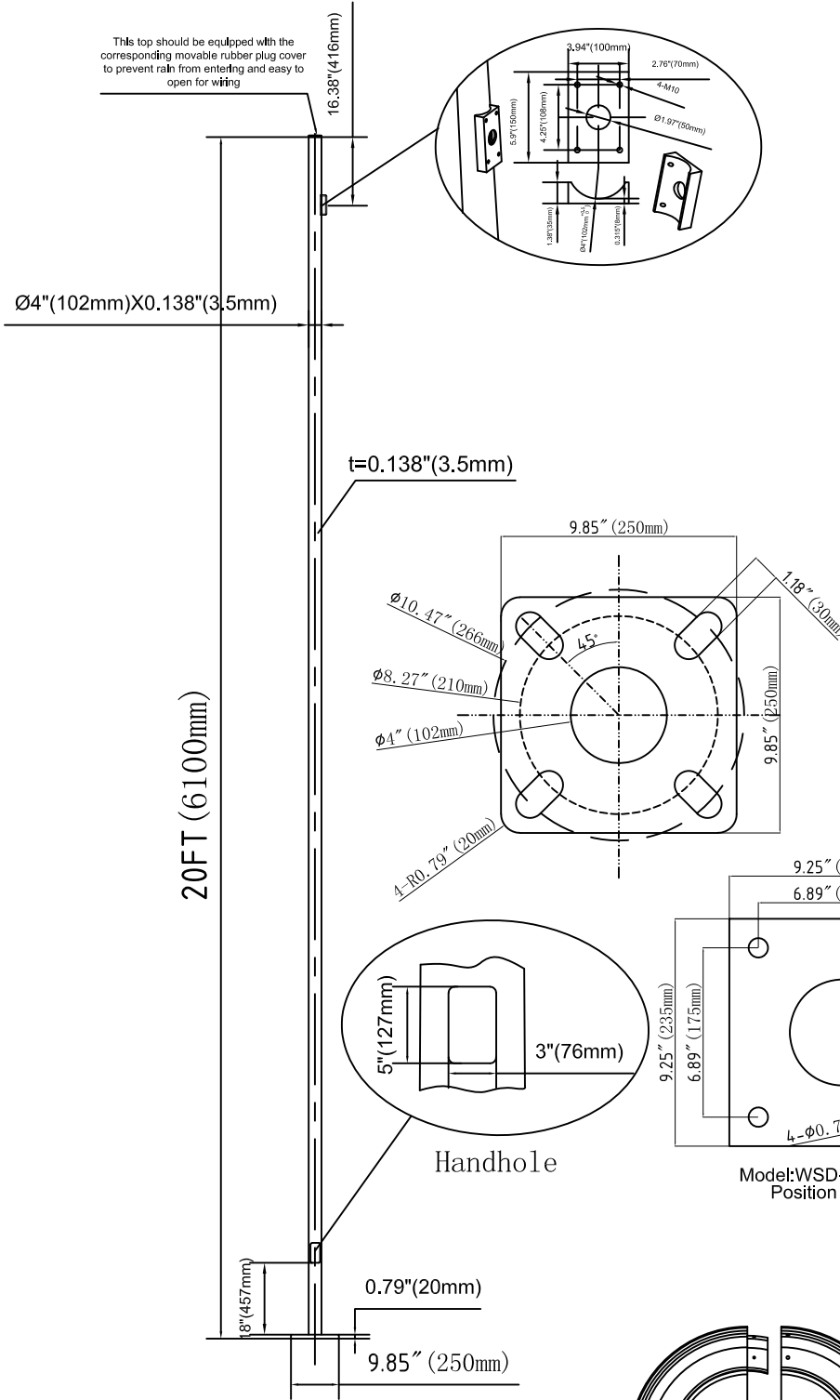

Technical requirements

1. The light pole shall be made of Q235 steel, The surface and inside of the light pole shall be dipped in zinc and then sprayed on the surface. Failed to chamfer 0.5MM.
2. All welding (electrode) shall be full, and there shall be no false welding, burr or other defects.
3. The unmarked tolerance shall be executed according to the common tolerance table.
4. Meet RoHS standards.

		edition		Modifier	Time of modification	Repair the interior	
Material No.	312.0639	Edition	A/1	Page	1/1	Tolerance requirements:(tolerance without special requirements)	
Material Name	WSD-R20FT4-10G-G	proportion	1:1	Angle	NO ± 0.2	mapping	Date
Specification Description		unit	mm		.x ± 0.1	check	
Drawing Number		material quality			.xx ± 0.05	examine and verify	
					.xxx ± 0.015		