

triv™ next



nuna®



Thank you!

You've just purchased a Nuna product, and you can be sure that your child is getting the best there is. Our products are expertly engineered for safety, with luxury fabrics and sophisticated style. Whatever made you fall in love with Nuna, rest assured your adventures with your little one will be easier from now on, freeing you to enjoy more happy family moments together.



IMPORTANT!
KEEP THESE
INSTRUCTIONS FOR
FUTURE REFERENCE:
READ CAREFULLY

Contents

Product Information

Product Registration	4
Warranty	4
Contact	4

Child Usage Requirements 5

Warnings 6

Parts List 8

Product Setup 10

Product Use 14

Accessories 22

Cleaning and Maintenance 26

Product Information

Model Number: _____

Manufactured in (date): _____

Product Registration

Please fill in the above information. The model number and the manufactured in date are located on a label on the stroller frame. Fill out the prepaid registration postcard attached to the product and mail it today.

To register your product, please visit:

www.nunababy.com

Click on the “Register Gear” link on the homepage.

Warranty

We have purposely designed our high-quality products so that they can grow with both your child and your family. Because we stand by our product, our gear is covered by a custom warranty per product, starting from the day it was purchased. Please have the proof of purchase, model number and manufactured in date available when you contact us.

For warranty information please visit:

www.nunababy.com/warranty

Contact

For replacement parts, service, or additional warranty questions, please contact our customer service department.

In the USA:

infousa@nunababy.com

www.nunababy.com

1.855.NUNA.USA

Child Usage Requirements

This stroller is suitable for use with children who meet the following requirements:

Weight: up to 50 lb maximum (22.7 kg)

Height: up to 45 inches (114.3 cm)

When using the stroller frame with a PIPA™ series infant carrier, refer to the child usage requirements listed in the infant carrier instruction manual.

WARNING

Failure to follow these warnings and instructions could result in serious injury or death.

A child's safety is your responsibility. **NEVER** leave your child unattended.

To avoid any danger of suffocation, remove all plastic covers before using the stroller and destroy or keep away from babies and children!

Keep small parts away from children as they pose a choking hazard.

Discontinue using the stroller if it becomes damaged or broken.

DO NOT make any changes or modifications to the stroller that are not specified in this manual.

Use original Nuna parts and accessories only.

Overloading, incorrect folding, and using accessories other than those approved by Nuna, e.g. child seats, bag hooks, rain covers, buggy boards, etc., may damage or make the stroller unsafe.

Use of the stroller with a child weighing more than 50 lb (22.7 kg) or taller than 45 inches (114.3 cm) in height will cause excessive wear and stress on the stroller, and could create an unstable condition. Use the stroller with only one child at a time.

To prevent a hazardous, unstable condition, do not place more than 10 lb (4.5 kg) in storage basket and never place purses, shopping bags, parcels or other items on the handle or canopy. To prevent a hazardous, unstable condition, do not place more than 1 lb (0.45 kg) in the storage pocket on the back of the seat.

DO NOT use storage basket as a child carrier.

Avoid serious injury from falling or sliding out. **ALWAYS** use seat belt. After fastening buckles, adjust belts to get a snug fit around your child.

AVOID FINGER ENTRAPMENT Use care when folding and unfolding the stroller. Be certain the stroller is fully erected and locked before allowing your child near the stroller.

STRANGULATION HAZARD Do not place items with a string around your child's neck, suspend strings from the stroller, or attach strings to toys.

DO NOT let your child play with the stroller.

ALWAYS keep your child in view while in the stroller.

NEVER allow your child to stand on the stroller.

ALWAYS check that the ring adapter is correctly engaged before use.

The parking brake **MUST** be engaged when the stroller is stopped and when placing and removing child.

Negotiate curbs and rough ground carefully. Repeated impact could cause damage to the stroller.

The stroller is to be used only at walking speed and is not intended for use while jogging, skating, etc.

NEVER use the stroller on stairs or escalators. You may suddenly lose control of the stroller or your child may fall out.

The stroller does not replace a crib or a bed. Should your child need to sleep, they should be placed in a crib or sleeping area based on your child's requirements.

ALWAYS allow the fabric to dry naturally away from direct heat.

DO NOT leave the stroller exposed in the vicinity of a strong source of heat, i.e. a radiator or open fire, or store the stroller in a damp place.

Magnetic Harness Buckle: The buckle and buckle clips contain magnets. If your child has a medical condition that prohibits the use of magnets near the child, do not use the stroller. Call Nuna to arrange an alternative product or different restraint solution.

Be mindful of the possible interaction of magnets in buckles and certain electronic devices.

Parts List

Make sure all parts are available before assembly. If any part is missing, please contact Nuna (see page 4 for information). No tools are required for assembly.

- | | | | |
|-----------|--------------------------------|-----------|--------------------------------------------------------------|
| 1 | Front Wheel (x2) | 17 | Buckle |
| 2 | Rear Wheel (x2) | 18 | Shoulder Harness Pad |
| 3 | Adapter Release Button | 19 | Handle |
| 4 | Car Seat Ring Adapter | 20 | Handle Adjustment Button |
| 5 | Adapter Fold Strap | 21 | Rear Wheel |
| 6 | Canopy | 22 | Brake Lever |
| 7 | Arm Bar | 23 | Stroller Fold Strap (under the seat) |
| 8 | Insert | 24 | Storage Pocket |
| 9 | Seat Pad | 25 | Recline Adjustment Button |
| 10 | Calf Support | 26 | Fold Button (in the middle of the Recline Adjustment Button) |
| 11 | Front Wheel | 27 | Canopy Window |
| 12 | Swivel Lock | 28 | Rain Cover* |
| 13 | Storage Basket | | |
| 14 | Calf Support Adjustment Button | | |
| 15 | Stroller Frame | | |
| 16 | Seat Release Button | | |

*Sold separately

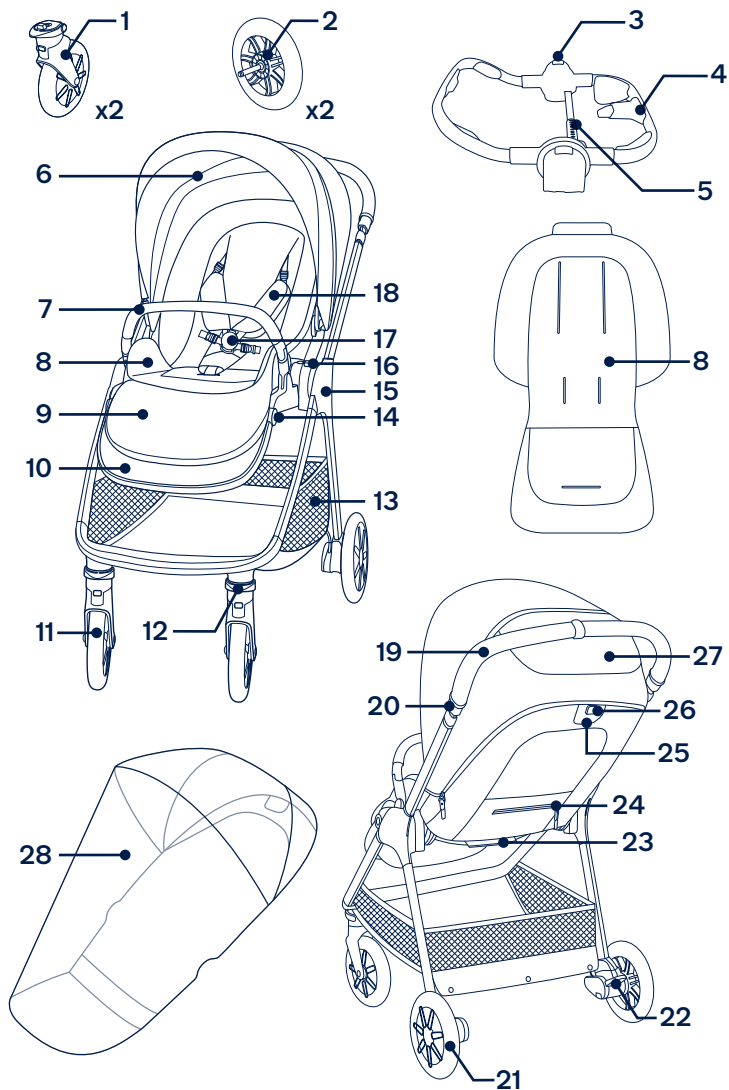

Product Setup

Open Stroller

1 - Lift the handle to open the stroller frame.

2 - Pull the seat up towards the handle.

A “click” sound means the seat is open.

Check that the stroller is open completely and locked before continuing.

Front Wheels

3 - Slide the front wheel onto the end of the front leg.

A “click” sound means the front wheel is assembled completely.

Check that the wheel is securely attached by pulling out.

Repeat on opposite side.

4 - To remove the front wheel, press the release button **(1)** and detach the front wheel from the front leg **(2)**.

Rear Wheels

5 - Insert the rear wheel into the rear leg. A “click” sound means the rear wheel is assembled completely.

Check that the wheel is securely attached by pulling out.

Repeat on opposite side.

6 - To remove the rear wheel, press the release button **(1)** and detach the rear wheel from the rear leg **(2)**.

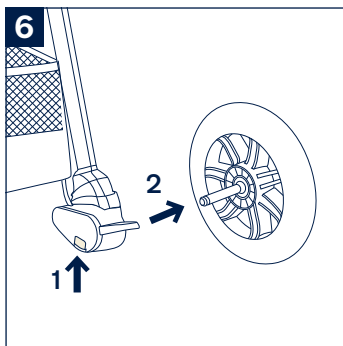
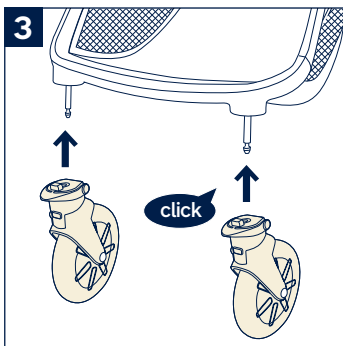
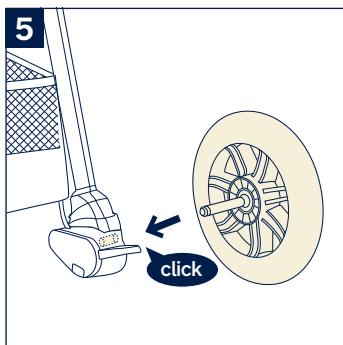
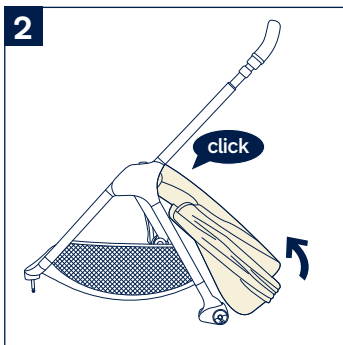
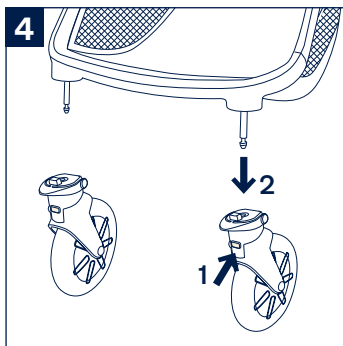
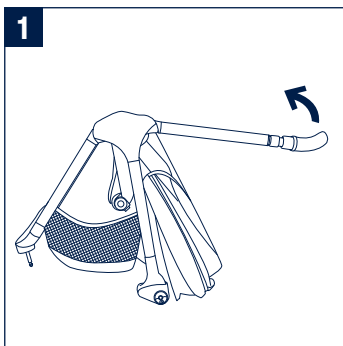

Arm Bar

 It is always recommended that the arm bar be used, but it is not a restraint device. Always secure the child with the harness.

- 1 - Align the arm bar ends with the arm bar mounts, and insert until it clicks into place. A “click” sound means the arm bar is assembled completely.
- 2 - To remove the arm bar, press the arm bar release buttons (1) and lift the arm bar up (2).

Insert

- 3 - To assemble the insert, place the insert over the seat pad and thread the shoulder, waist and crotch harness straps through their respective slots.

Check Setup

- Stroller frame is fully open and locked.
- Rear and front wheels are securely attached.
- Arm bar is securely attached.

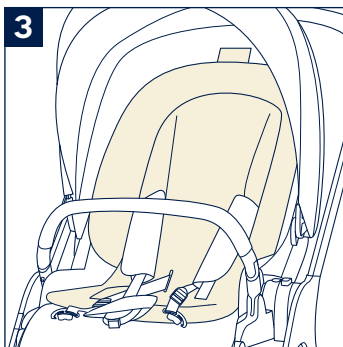
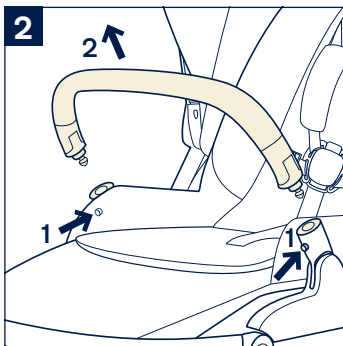
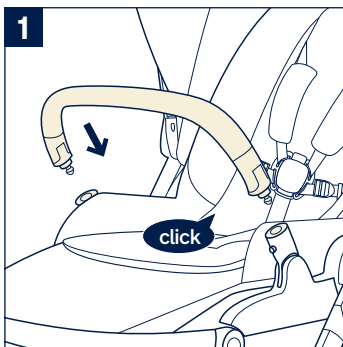

Product Use

Canopy

- 1** - To open the canopy, pull the canopy toward the front of the seat. To close the canopy, push it back.
- 2** - Unzip the zipper for extra shade.
- 3** - For added ventilation, flip the canopy window cover up.

Front Swivel Locks

In Use Position:

It is recommended to use the front swivel locks on uneven surfaces.

- 4** - Pull the front swivel lock up **(1)** to lock the front wheel and push down **(2)** to unlock it.

Fold Position:

Lock the wheels forward of the stroller frame before folding. This allows the stroller to stand on its own.

- 5** - With the front wheel forward of the stroller frame, pull the front swivel lock up **(1)** to lock the wheel and push down **(2)** to unlock it.

Brake

- 6** - To lock the rear wheels, step down on the brake lever.
To unlock the rear wheels, step down on the brake lever again.

-  Always apply the brake when the stroller is stopped. Push the stroller slightly to ensure the brake is engaged.

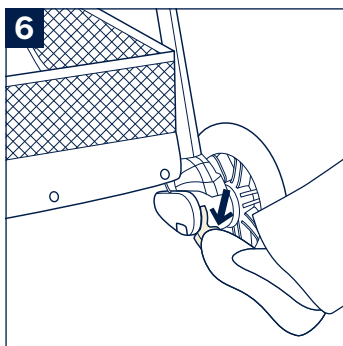
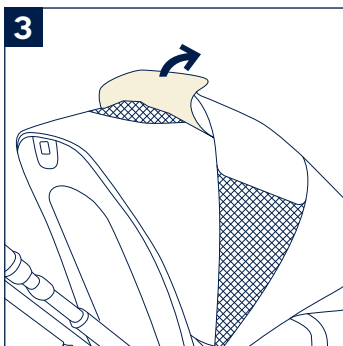
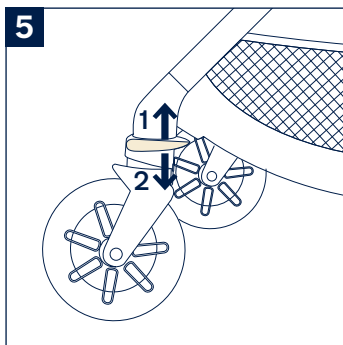
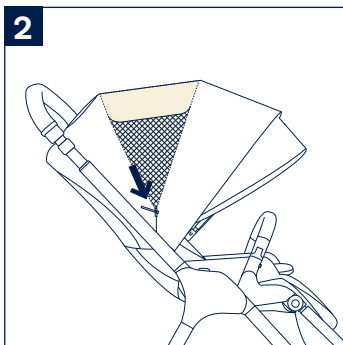
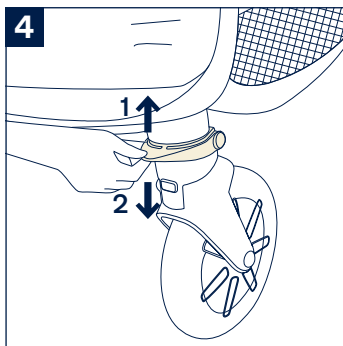
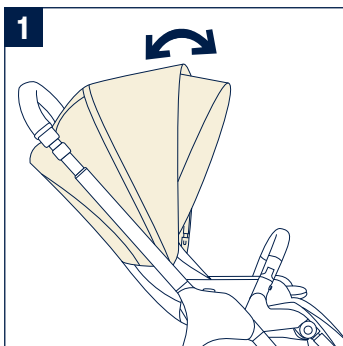

Handle

The handle has 5 positions.

- 1 - To adjust the height of the handle, pull the handle adjustment button **(1)** and move the handle up or down **(2)**.

Recline

There are 3 recline positions.

- 2 - To recline the seat, pull the recline adjustment button **(1)** and tilt the backrest up or down **(2)**.

Calf Support

The calf support has 2 positions.

- 3 - To raise the calf support, lift up until it locks into position with a “click.”
To lower the calf support, press the calf support adjustment buttons **(1)** and push the calf support down **(2)**.

Storage Pocket

- 4 - Use the storage pocket on the back of the seat for lightweight storage.

 To prevent a hazardous, unstable condition, **DO NOT** place more than 1 lb (0.45 kg) of items in the storage pocket.

Reverse Seat

- 5 - Press the seat release button **(1)** and lift the seat up **(2)**.
- 6 - Reverse the seat, and then attach it to the frame.
A “click” sound means the seat is attached completely.

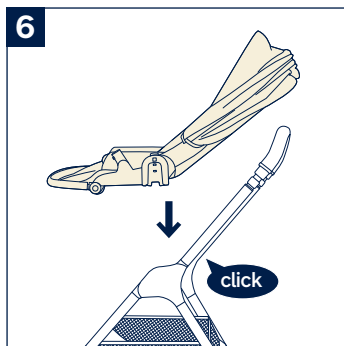
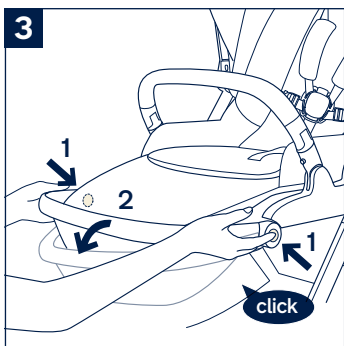
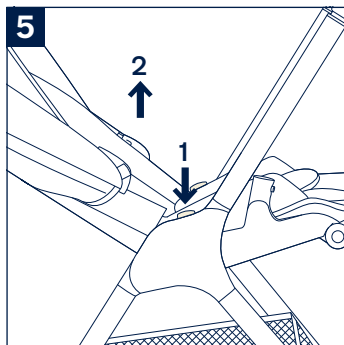
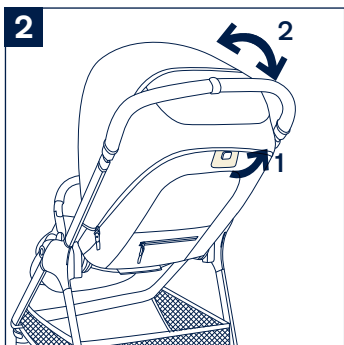
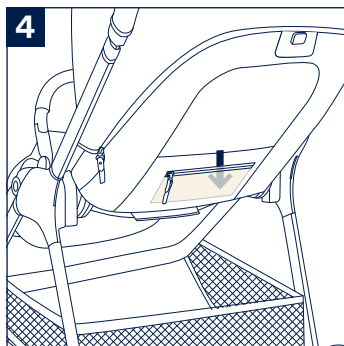
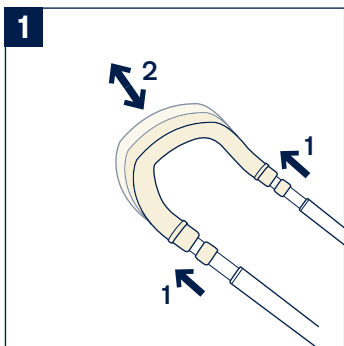

-  The parking brake **MUST** be engaged when the stroller is stopped and when placing and removing child.

Securing Your Child

- 1** - Push the top button on the buckle **(1)** to release the buckle latch and remove the magnetic clips **(2)**.

Place your child in the stroller.

- 2** - Insert the magnetic clips into the buckle.
- 3** - Fit the harness snugly to your child by sliding the adjustment straps to tighten **(1)**. Then pull the waist adjustment straps out **(2)**.

Shoulder Harness Position

- 4** - The upper shoulder harness buckles can be moved up and down for added adjustment.

-  To avoid serious injury from falling or sliding out, always secure your child with the harness.

Make sure the harness is adjusted properly and your child is snugly secured. The space between the child and the shoulder harness should be about the thickness of one finger. **DO NOT** cross the shoulder belts. This will cause pressure on your child's neck.

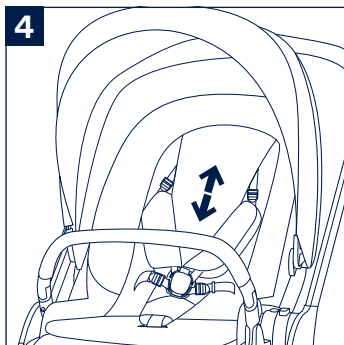
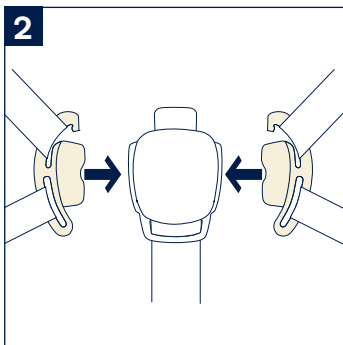
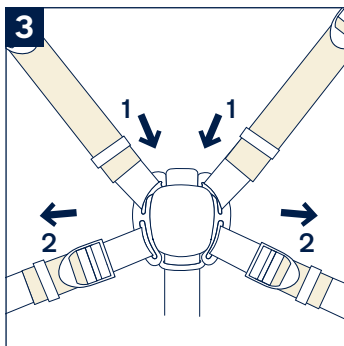
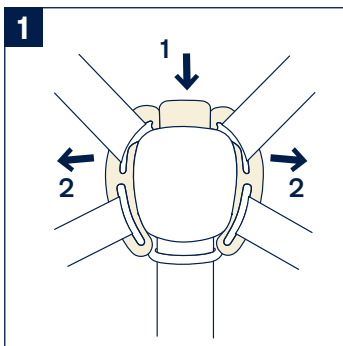

Fold

Before folding:

Adjust the handle to the lowest position.

Lock the front wheels in the fold position using the swivel locks (page 14).

After folding (to stand):

Let the stroller rest on its handle and front wheels.

With Seat Attached

- 1 - Close the canopy.
- 2 - Press the fold button **(1)** on the middle of the recline adjustment button, then pull the recline adjustment button **(2)**.
- 3 - Fold the seat down.
- 4 - Pull the stroller fold strap to fold the stroller.

Without Seat Attached

- 5 - Press the fold release buttons on the seat mounts **(1)**. While pressing the fold release buttons, pull up on the stroller frame at the seat mounts **(2)** and the stroller will begin to fold.
 For safety, hold the stroller frame only at the seat mounts, not where the frame legs fold.
- 6 - Fold the stroller completely by rotating the handle down.

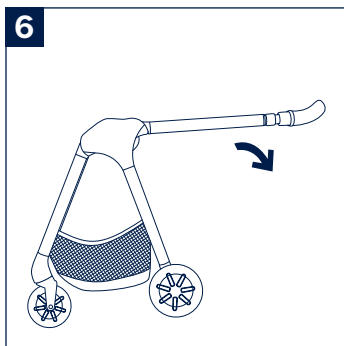
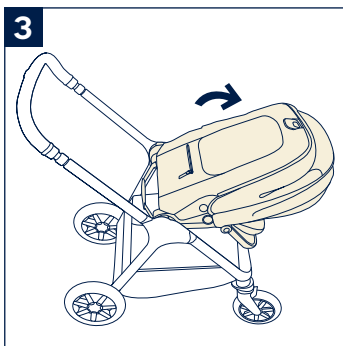
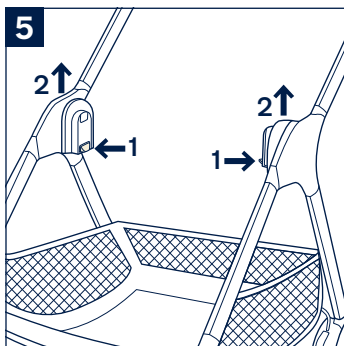
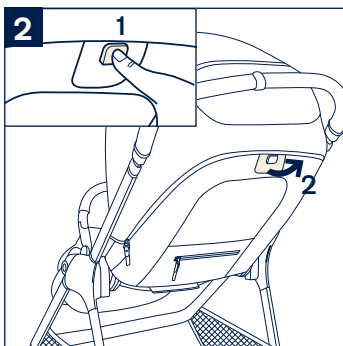
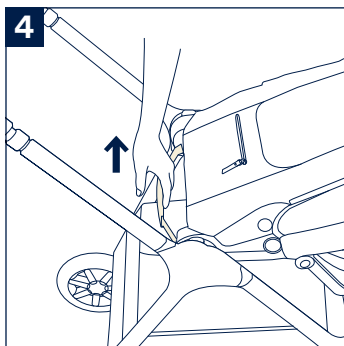
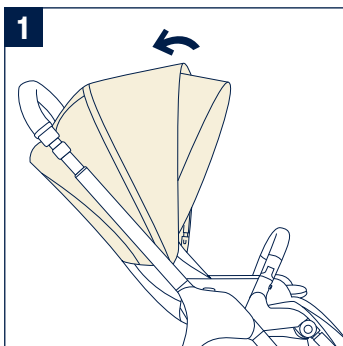



Accessories

Car Seat Ring Adapter

Use the car seat ring adapter only with a Nuna PIPA™ series infant carrier in combination with a Nuna TRIV™ next stroller.

See PIPA™ series instruction manual for proper usage of the infant carrier.

- 1** - To attach the car seat ring adapter, place the ring adapter on the seat mount. A “click” sound means the ring adapter is attached.
- 2** - To attach the infant carrier, place the infant carrier on the ring adapter. A “click” sound means the infant carrier is attached.
-  Pull up on the infant carrier to check that it is securely attached to the adapter and that the adapter is securely attached to the stroller.
- 3** - The ring adapter can be attached so that the infant carrier is rear facing or forward facing.
- 4** - To remove the infant carrier, squeeze the release button located on the back of the infant carrier **(1)** and lift up **(2)**.
-  Remove the infant carrier before folding.
- 5** - To fold the stroller with the ring adapter attached, pull the adapter fold strap.
- 6** - To remove the ring adapter (with the stroller unfolded), push the adapter release buttons **(1)** and lift the adapter up **(2)**.

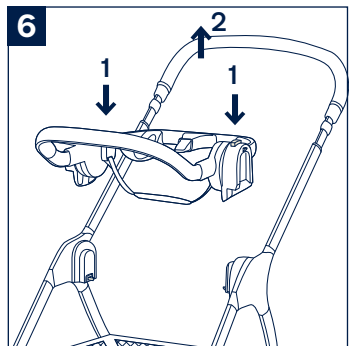
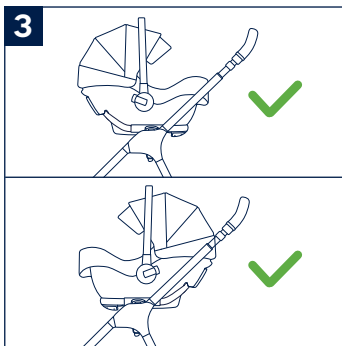
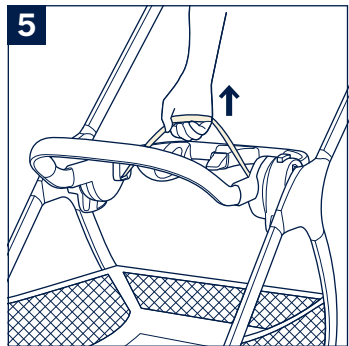
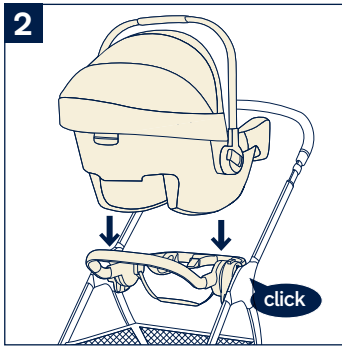
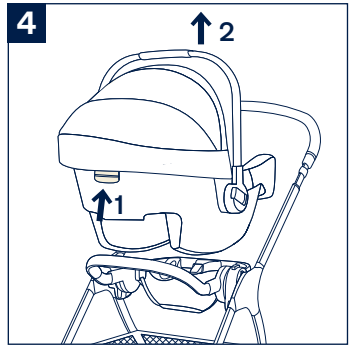
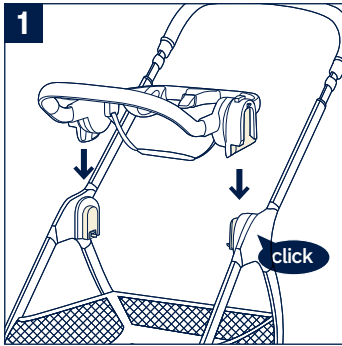

Accessories

Rain Cover*

1 - To assemble the rain cover, place it over the stroller.

ALWAYS check ventilation when the rain cover is on the product.

ALWAYS check that the rain cover has been cleaned and dried before folding.

DO NOT fold the stroller with the rain cover in place.

DO NOT place your child into the stroller with the rain cover in place during hot weather.

*Sold separately



Cleaning and Maintenance

Refer to the care label attached to the fabric for washing and drying instructions.

Clean the frame, plastic parts, and fabric with a damp cloth, but do not use abrasives or bleach. Do not use silicon lubricants as they will attract dirt and grime. Do not store your stroller in a damp place.

Clean the stroller wheels regularly with water and remove any dirt.

To ensure long-lasting use, wipe off this product with a soft, absorbent cloth after using it in rainy weather.

It is normal for fabric to color from sunlight and to show wear and tear after a long period of use, even when used normally.

For reasons of safety, only use original Nuna parts.

Check regularly if everything functions properly. If any parts are torn, broken, or missing, stop using this product.

