

ULTRALIFE[®] Batteries

We. Are. Power.[™]

3 Volt, D-Size Cell

Technical Datasheet

The Ultralife Advantage

Better technology. Our lithium-based (lithium-manganese dioxide, lithium ion and lithium polymer) technologies enable us to design leading-edge power solutions for the world's most demanding applications.



FEATURES

- High energy density
- No voltage delay
- Wide operating temperature range
- Lightweight
- 10-year shelf life
- Long operating life

APPLICATIONS

- Consumer Telematics
- Commercial Telematics
- Search & Rescue Devices
- Military Communications, Detectors & Imaging
- Medical Devices

SPECIFICATIONS

Part No	U10013, U10014, U10015, U10016 (see note 2)
Voltage Range	1.5 to 3.3 V
Average Voltage	3.0 V
Nominal Capacity	11.1 Ah @ 250 mA to 2.0 V @ 23° C
Max. Discharge	3.3 A continuous
Pulse Capability	Up to 7.0 A Varies according to pulse characteristics, temperature, cell history and the application. Consult Ultralife.
PTC (re-settable fuse)	See note 3
Weight	115 grams
Operating Temp	-40° C to 72° C
Storage Temp	-40° C to 95° C
Exterior/Housing	Hermetic Ni-plated steel can with Mylar sleeve
Terminals/Connector	Flat Ni-plated +/- End Caps (U10013 and U10014) Flat Ni-plated +/- End Caps with Nickel Tabs (U10015 and U10016)
Safety	UL component recognized. Material Safety Datasheet – MSDS023.
Transportation	Excepted – U.S.; Class 9 – Int'l. See note 1.

Note 1	For a complete description of transportation regulations and definitions of the transportation classifications "Excepted" and "Class 9," refer to the Ultralife web site at www.ultralifebatteries.com .
Note 2	U10013 and U10014, Flat Ni-plated +/- End Caps U10015 and U10016, Flat Ni-plated +/- End Caps with Nickel Tabs
Note 3	U10014 and U10016 have PTC (re-settable fuse) U10013 and U10015 do NOT

DIMENSIONS

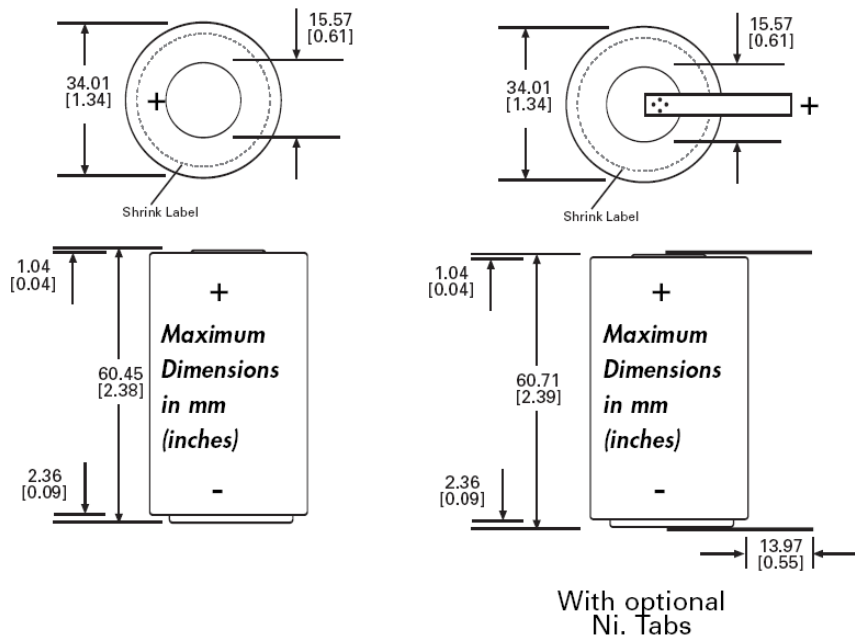

PERFORMANCE GRAPHS

