

1001A

PALLET WRAPPER

Our wide range of pallet wrapping machines are best-in-class for design, functionality and ease of use. All our machines can be customised with features to ensure you get maximum yield and efficiency from your wrap.

- User-friendly control panel
- 2,000kg capacity heavy duty turntable
- High-speed operation
- Easy-to-use friction brake with release



SPECIFICATIONS

1001A

FEATURES

- User-friendly control panel
- High-speed operation
- Easy-to-use friction brake with release and tension override for precise tension control
- 2,000kg capacity heavy duty turntable
- Semi-automatic operation
- 4 wrap cycles
- Electronic eye sensor
- Same start/stop position for turntable
- Soft start and stop for turntable
- Schneider (German) inverters for turntable and film carriage
- Variable carriage speed
- Variable turntable speed
- Forklift transportable

TECHNICAL

- Wrapping height: 2.2m
- Turntable diameter: 1.5m
- Turntable height: 80mm
- Pallet weight limit: 2,000kg
- Film diameter limit: 350mm
- Film core limit: 76mm
- Film width limit: 500mm
- Film thickness: 12-35um
- Turntable speed: up to 12rpm
- Power supply: single phase / 240v / 50Hz

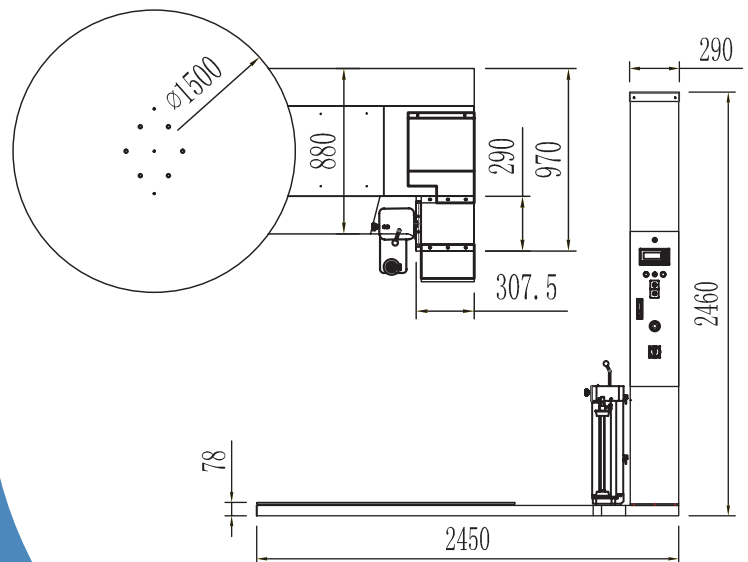

12-MONTH WARRANTY