

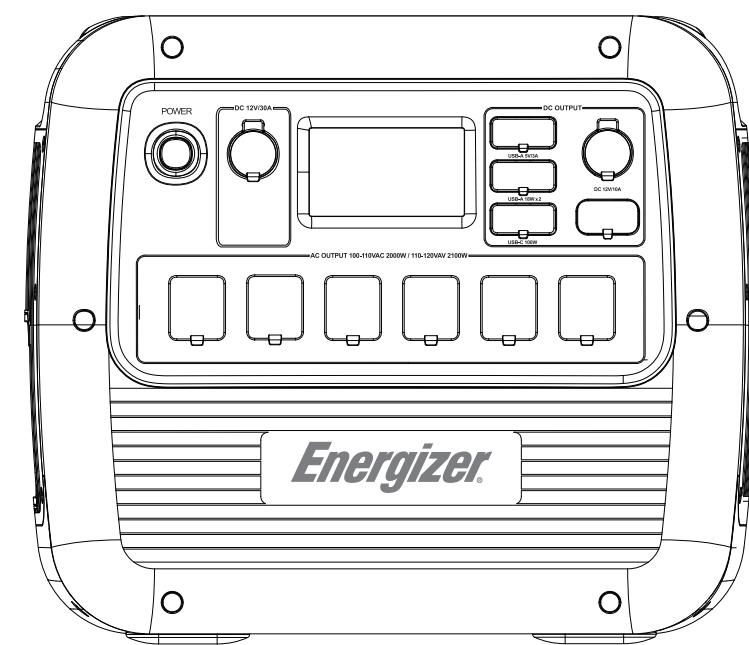

USER MANUAL

PPS2000W01 Power Station



Energizer PPS2000W01 Portable Power Station

No more worries about being outdoors or having a power outage. With 2150Wh capacity and up to 2100W AC output, PPS2000W01 always keeps you charged at any on-the-go moment. Featuring 100W USB-C PD, 2100W AC power outlet and USB-A charging ports, PPS2000W01 provides 17 outputs that can charge multiple devices or appliances simultaneously and efficiently. With premium battery and PowerSafe management, Energizer Portable Power Station PPS2000W01 is your most reliable and safe power solution anytime, anywhere.

⚠ ATTENTION

- A.The specifications and the pictures in this manual are for reference only.
- B.The product is perfect for off-grid power needs or backup power for emergency situations.
- C.Actual AC outlet and AC adapter will be different depending on the locations of the customer.
- D.To maximize the battery life, please fully charge the product before using it for the first time.

Get To Know Your Product

1.Quick Guide

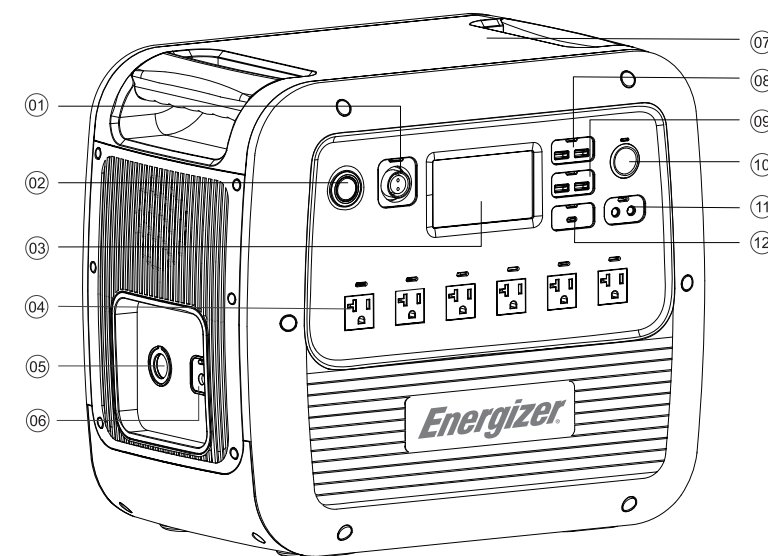

- | | | |
|---------------------|----------------------|-------------------------|
| 01 Aviation Output | 05 Aviation Input | 09 USB-A 18W |
| 02 Power Button | 06 AC Adapter Input | 10 12V DC Charging Port |
| 03 LCD Touch Screen | 07 Wireless Charging | 11 DC 5521 Output |
| 04 AC Output ×6 | 08 USB-A Output | 12 Output PD100W |

Charging Your Product

⚠ ATTENTION

If the ambient temperature is too high or the battery temperature is higher than 60 °C due to continuous high-power discharge, the product cannot be charged. When the battery temperature is less than 55 °C, the charging function will automatically resume. If the battery is not used for a long time, the battery should be stored in a dry and ventilated room with an ambient temperature of 0-35 °C for more than 3 months, and the battery should be charged to 50%-80%.

1.LCD Battery Display

As you use your product, segments will disappear from the display, indicating the remaining charge. When charging your product you will notice a battery segment blinking at a 1 second interval status. Once your product is fully charged, all battery segments will be lit and remain solid.

2.Charge Through Solar Panel

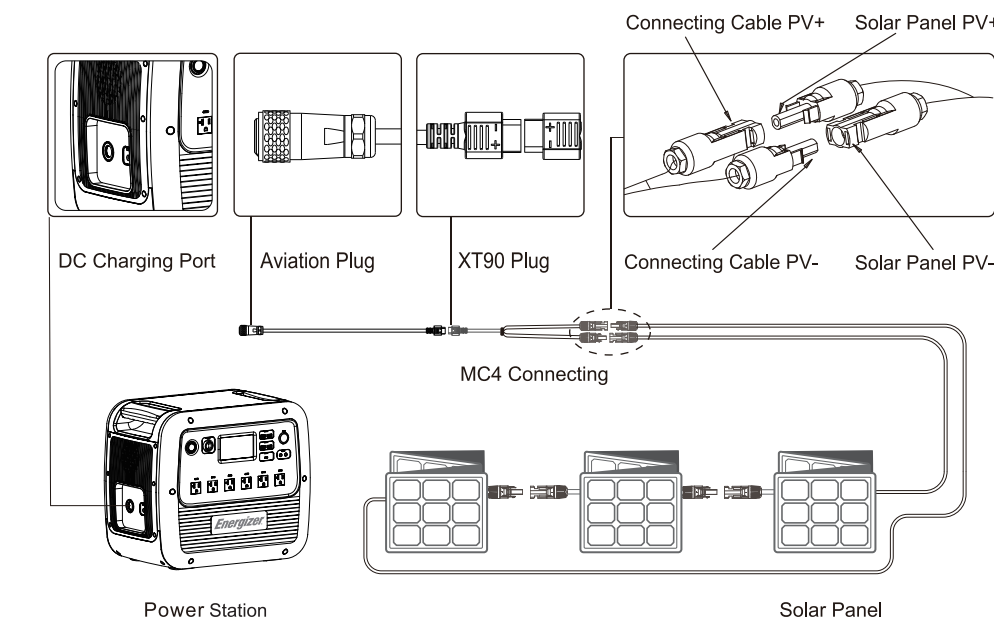

- A.Place your solar panel where it will get as much strong direct sunlight as possible.
- B.Connect the output port of the solar panel with the input port of the product to start charging. You will know the product is being charged when the LCD displays the charging percentages on the screen. The product is fully charged when displays 100%.

⚠ Notes:

The actual charging efficiency can vary widely depending on weather, ambient temperature, sunlight, and the angle that the solar panel faces to the direct sunlight and other factors. The maximum output voltage of the solar panel should not exceed 145V.

In order to ensure solar charging efficiency, it is recommended to use solar panels with an open circuit voltage of 10-145V. The maximum current can reach 15A.

3.Charge Through AC Adapter

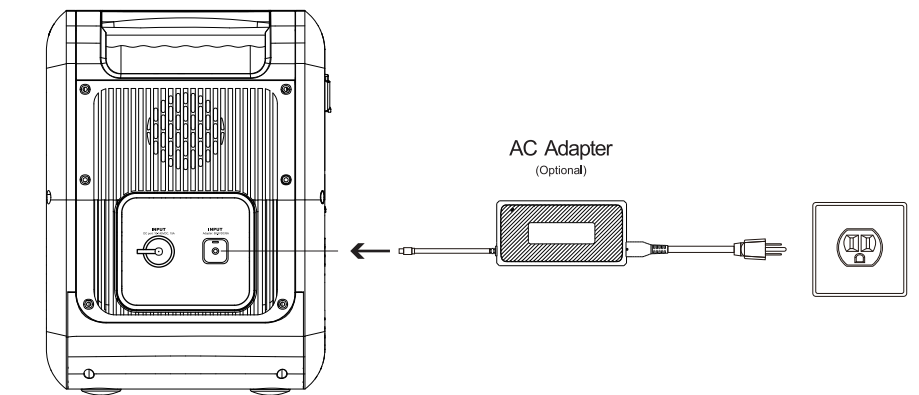

Plug the adapter (optional) into its DC input port and you will see the state of charge displayed in the screen.

⚠ Notes:

- A.The product is fully charged when battery displays 100% capacity on the screen. After the product is fully charged, please unplug the AC wall charger as soon as possible.
- B.Usually, it takes about 5 hours to fully charge the machine using the original power adapter.

4.Charge Through Your Car

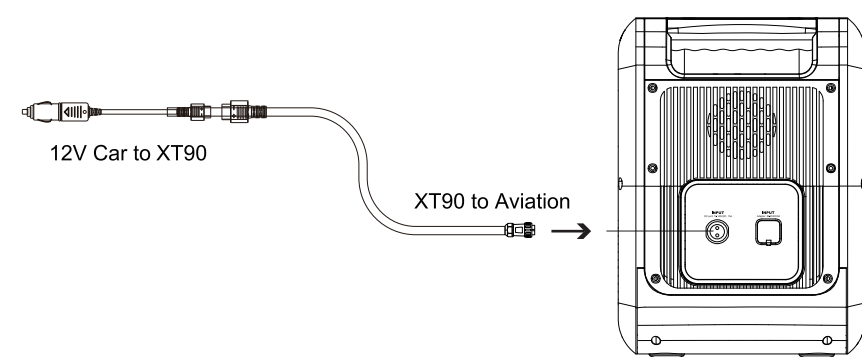

- A.Plug the car charger into the 12 V DC Charging Port of your car, and then plug into the DC input port of the machine.
- B.The original car charger features a 10A protector tube to protect your car.
- C.The product is fully charged when the battery displays 100% capacity on the screen.

5.Charge Through Lead-Acid Battery

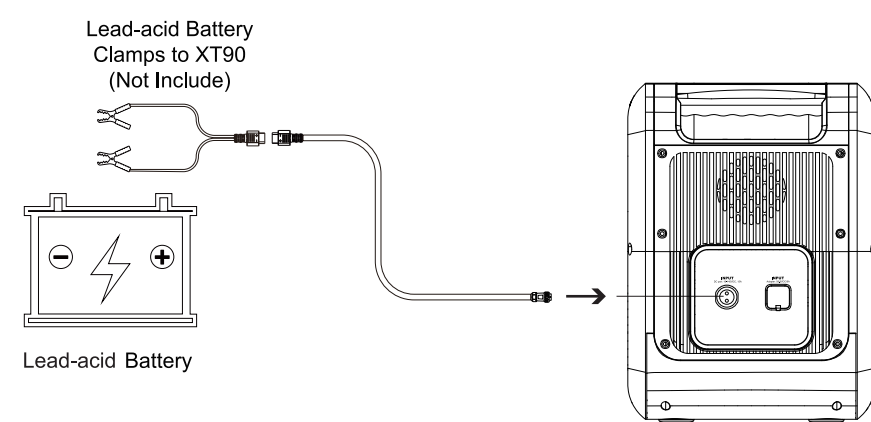

- A.Take proper precautions whenever handling a Lead-acid battery. Wear protective eye glasses and gloves to protect yourself from any acid that may leak from the battery.
- B.Connect the charger's red positive (+) cable clamp to the positive (+) post.
- C.Secure the black negative (-) cable clamp to the negative (-) post.
- D.Plug the charger into the Aviation input socket.

⚠ Notes:

To avoid car battery power loss, you should charge this product through your 12V DC Charging Port only when your car engine is started.This function is for 12V cars ONLY.

Protection mode (DC input)

- A.Due to the different models of cars, it may not be fully charged.
- B.Under-voltage protection: The power generator can't be charged if the voltage of your car is too low.

6. AC+DC Dual Charging

Plug your AC and DC charger to speed up charging.

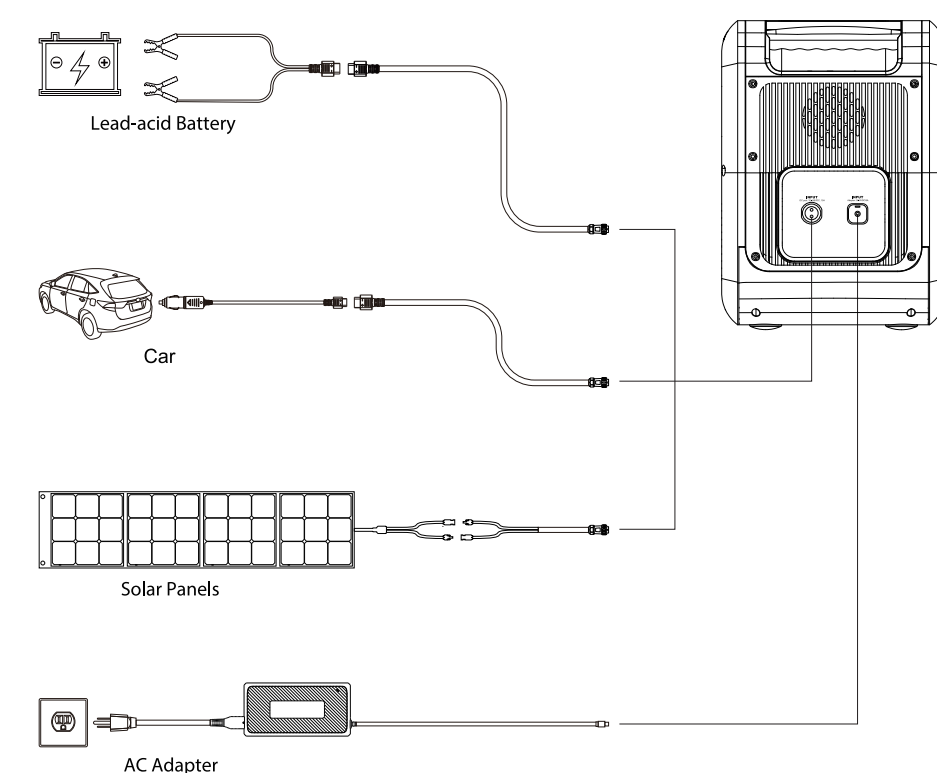

Using Your Product

1. Buttons & Switches

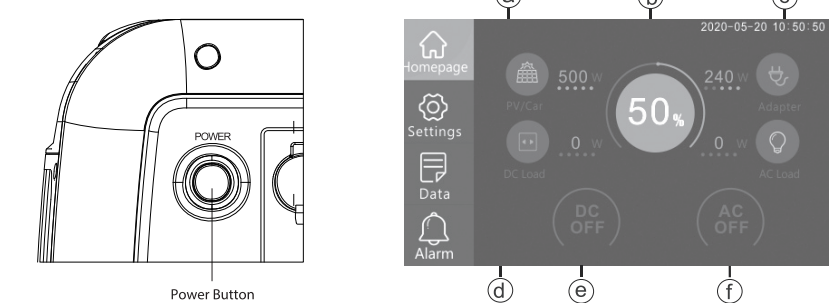

- | | |
|------------------------------|----------------------------|
| a.PV/ Other Charging Display | e.DC ON/ OFF Switch |
| b.BMS Info | f.AC ON/ OFF Switch |
| c.Date/ Time | g.Adapter Charging Display |
| d.DC Load Info | h.AC Load Info |

- A.Press the power button to turn the machine on. Press again to turn the machine off.
- B.Tap the switch on the screen in the homepage to turn your output mode ON/ OFF.

2.USB Output Function

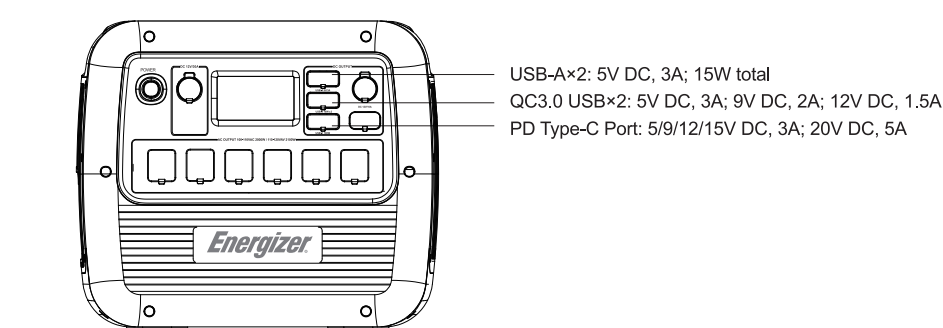

When two USB-A 5V/3A ports are used simultaneously, the two ports can only output 5V/3A total, so it cannot enter the fast charging mode.

3.DC Outputs

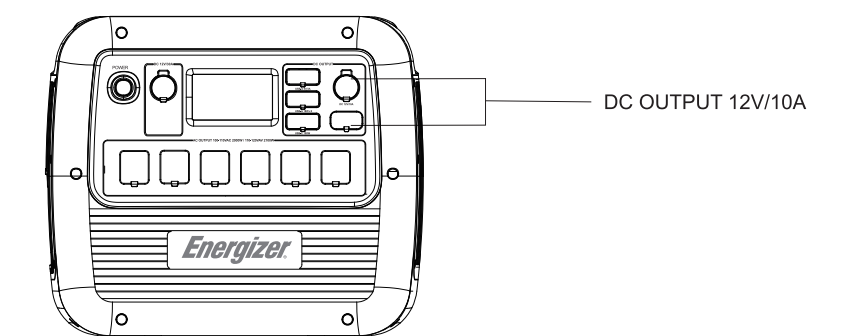

- A.The 12V DC Charging Port and The DC5521 (5.5mm in diameter) 11.2-14.6V ports offer max 10A output current and automatically distributes max current according to the external connected devices to ensure shortest charging time.
- B.The DC5521 port can be connected with a 12V DC Charging Port (power requires no more than 120 W).

⚠ Notes:

If the output DC and USB of the product are greater than 32A at the same time, the buzzer alarms after the product runs for three minutes. The LCD error code is E11. If the alarm lasts for 30 seconds and is not cleared, the product will forcibly shut down the DC output to reduce the total DC output current and ensure the safety of the product. In vehicle charging mode, when the voltage of the charging port is lower than 11.2V, the charging function will stop charging to avoid over-discharge of vehicle power.

Protection mode (DC outputs)

Short circuit protection: when short-circuit occurs to the external devices, the machine starts beeping and stops charging.

Product Specifications

Battery

Battery	LiFePO4 Battery
Battery Capacity	2150Wh, 51.2VDC, 42000mah
Lifecycles	2000 Cycles to 80% Capacity
Battery Maintenance	Charge Every 3-6 Months

Port (Output)

USB-A*2	5V DC, 3A; 15W total
QC3.0 USB*2	5V DC, 3A; 9V DC 2A; 12V DC, 1.5A
PD Type-C Port	5/9/12/15V DC, 3A; 20V DC, 5A
DC 5521*2	12V, 10A total
Car Charging	
RV/Aviations Sockets	12V, 30A
Wireless Charging*2	5/7.5/10V DC, 15W*2
AC Output*6	100V AC, 2000W total; 110V AC, 2100W total

Charging (Input)

Solar Charging	10-145V DC, 15A, 900W Max
Car Charging	11-28.8V, 8.2A
Battery Charging	

General

Weight	About 66.1 lbs/ 30 kg
Dimensions	17.3×11.6×15.3 in
Discharge Temp	-4-104°F (-20-40°C)
Charge Temp	32-104°F (0-40°C)

Cold Weather Usage

Cold temperatures can affect the product's battery capacity due to chemical characteristics of the battery. If you'll be living off grid in sub-zero conditions, it is recommended to keep your product in an insulated cooler, and connected to a power source (12V car/AC adapter/solar panel). The natural heat generated by the product contained in an insulated cooler will keep battery capacity at its highest level.

Disposal And Recycle

This product should not be disposed along with household waste. Please dispose or recycle this product and the battery inside according to the local rules and regulations.

Battery Information

This product has an internal, non-removable, LiFePO4 Rechargeable battery. Do not attempt to remove the battery, as you may damage the device.

Error Code

Code	Causes	Solutions
001	PV Over Voltage	Please check if the open circuit voltage of solar panels exceeds the input voltage standard of the power station.
004	DC Output Short Circuit	Please disconnect the appliances on DC output ports.
005	Adapter Over Voltage	Please check that the adapter output voltage meets the specification. Clear the alarm history or restart the unit.
006	Adapter Low Voltage	Please check that the adapter output voltage meets the specification. Clear the alarm history or restart the unit.
007	Adapter Relay Error	Clear the alarm history or restart the unit.
008	Adapter Over Current	Please check that the adapter output voltage meets the specification. Clear the alarm history or restart the unit.
010	USB/TYPE-C Over Current	Please disconnect the appliances on USB ports. Clear the alarm history or restart the unit.
011	12V/10A Over Current	Please disconnect the appliances on DC 12V/10A ports. Clear the alarm history or restart the unit.
012	12V/30A Over Current	Please disconnect the appliances on DC 12V/30A ports. Clear the alarm history or restart the unit.
014	DC Start Failure	Clear the alarm history or restart the unit.
015	DC Output Relay Error	Clear the alarm history or restart the unit.
016	Bus Start Failure	Clear the alarm history or restart the unit.
017	Inverter Start Failure	Turn on the AC after rebooting, please contact the dealer if the error still exists.
018	Bus Low Voltage	Turn on the AC after rebooting, please contact the dealer if the error still exists.
019	Bus High Voltage	Turn on the AC after rebooting, please contact the dealer if the error still exists.
020	Inverter Low Voltage	Please check if the output of the load meets the specifications of the unit. Turn on the AC after rebooting, please contact the dealer if the error still exists.
021	Inverter High Voltage	Please check if the output of the load meets the specifications of the unit. Turn on the AC after rebooting, please contact the dealer if the error still exists.
022	Inverter Low Frequency	Please check if the output of the load meets the specifications of the unit. Turn on the AC after rebooting, please contact the dealer if the error still exists.
023	Inverter High Frequency	Please check if the output of the load meets the specifications of the unit. Turn on the AC after rebooting, please contact the dealer if the error still exists.
025	Battery High Voltage	Please contact the dealer if the error still exists after rebooting the unit.

026	Battery Low Voltage	Please contact the dealer if the error still exists after rebooting the unit.
027	Battery Unconnected	Please contact the dealer if the error still exists after rebooting the unit.
028	Fan Error	Clean or replace the fan to ensure proper ventilation. Please contact the dealer if the error still exists after rebooting the unit.
029	NTC Error	Leave the unit at the recommended temperature few hours to recover. Please contact the dealer if the error still exists after rebooting the unit.
030	Calibration Error	Please contact the dealer if the error still exists after rebooting the unit.
031	Inverter Over Load	Please disconnect the load to make sure the output power of the loads meet the limit of the unit. Click to clear the alarm history.
032	Inverter Short Circuit	Please disconnect the load to make sure the load has been connected properly. Click to clear the alarm history.
033	DSP Communication Error	Please contact the dealer if the error still exists after rebooting the unit.
034	BMS Communication Error	Please contact the dealer if the error still exists after rebooting the unit.
035	EEPROM Read_write Error	Please contact the dealer if the error still exists after rebooting the unit.
036	Parameters of Control Module Error	Reset the configurations on "Settings". Please contact the dealer if the power station have not been recovered after rebooting.
041	BMS Temperature Error	Please store the power station at the recommended temperature and leave it until the temperature inside is back to the normal standard.
042	BMS Over Voltage	Please contact the dealer if the error still exists after rebooting the unit.
043	BMS Low Voltage	Please contact the dealer if the error still exists after rebooting the unit.
044	BMS Over Current	Please contact the dealer if the error still exists after rebooting the unit.
045	BMS Pre-charge Failure	Please contact the dealer if the error still exists after rebooting the unit.
046	BMS Output Short Circuit	Please contact the dealer if the error still exists after rebooting the unit.
051	AC Output Locked	Disconnect the load to make sure the output power of the loads meet the limit of the unit. Please contact the dealer if the error still exists after rebooting the unit.
053	USB/TYPE-C/PD Locked	Disconnect the load to make sure the output power of the loads meet the limit of the unit. Please contact the dealer if the error still exists after rebooting the unit.
054	12V10A Locked	Disconnect the load to make sure the output power of the loads meet the limit of the unit. Please contact the dealer if the error still exists after rebooting the unit.
055	12V30A Locked	Disconnect the load to make sure the output power of the loads meet the limit of the unit. Please contact the dealer if the error still exists after rebooting the unit.

Frequently Asked Questions

Q1: The temperature of the adapter is getting high when I charge, is that alright?
A: It's totally normal for the adapter to get warm, because of the heat produced in circuit during charging.

Q2: Why did the unit automatically shutdown with my appliance connected?
A: The "ECO MODE" (default) is set to shut down the unit when the AC output of the unit is lower than 50W in 4 hours for power saving.

Q3: What causes the cooling fan not to launch?
A: With the excellent heat dissipation design, the cooling fan will only launch when the total loads exceeds 30% of the rated output.

Q4: Can I charge and discharge the power station simultaneously?
A: Yes, it is supported, but not recommended in order to protect the lifespan of battery.

Q5: How to claim the warranty?
A: Please refer to the warranty card or the official website for further warranty policy.

Abbreviation Explain

DC/AC = Direct Current / Alternating Current

BMS = Battery Management System

PV = PhotoVoltaic (Solar Power)

CS = Charging State

4. AC Output

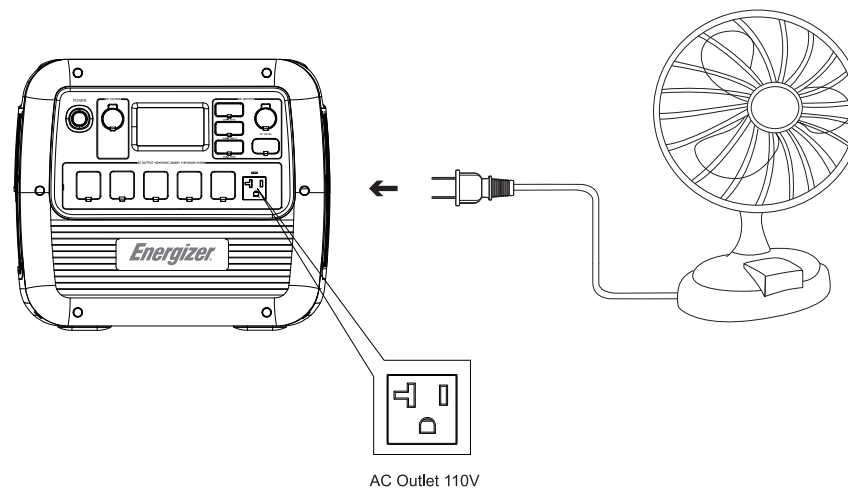

A. Plug the power cable of AC appliance into the AC outlet of the machine. Press the power button to enter AC mode.

B. Make sure the power of the connected AC appliance is less than 100V 2000W, 110V/120V 2100W.

Notes:

In the case of no operation, the LCD back-light will turn off after 1 minute as default. This time can be adjusted through the screen to 30 seconds, 1 minute, 5 minutes, and steady on. When the machine is in standby state, it will automatically shut down for 24 hours.

In ECO mode, the AC output is automatically turned off 4 hours after the AC output is unloaded. When the AC power is not in use, please turn off the AC power.

Protection mode: (AC output)

A. This product has undervoltage protection, overload protection and short circuit protection. The overtemperature protection is a double insulated circuit which is safe, reliable and efficient.

B. When overload, overtemperature or short circuit occurs, this machine will start beeping and the AC icon on the screen will flash, and then the machine automatically shut down to ensure safety.

Package Content

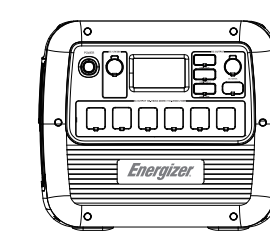

1 x 2150 Wh
Portable Power Station

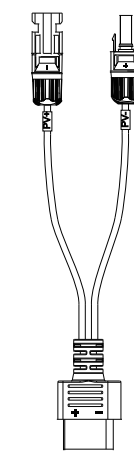

1 x Solar Charging Cable
(XT90 to MC4)

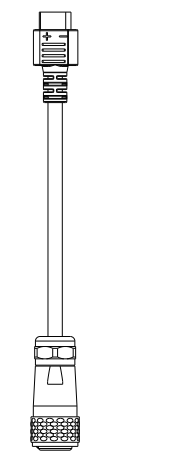

1 x Aviation Plug to XT60
(Output)



1 x XT60 to Anderson Plug
(Output)



1 x USB-C to USB-C Cable

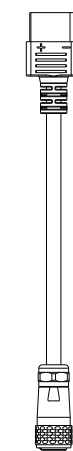

1 x XT90 to Aviation Plug
(Input)

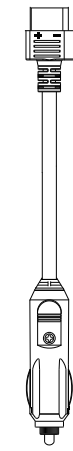

1 x Car Charging Cable
(Car Plug to XT90)

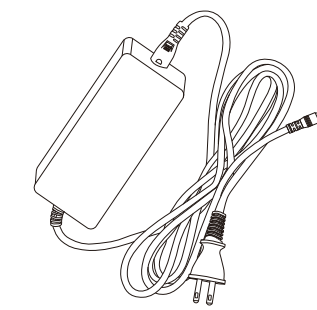

1 x AC-DC Adapter
(Optional)

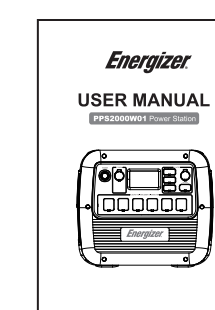

1 x User Manual

Caution

- Do not short-circuit the product. To avoid short-circuiting, keep the product away from all metal objects.
- Do not heat the product, or dispose of it in fire, water or other liquids. Keep it away from high ambient temperature. Do not expose the product to direct sunlight.
- Keep the product away from humid, dusty places.
- Do not disassemble or reassemble this product.
- Do not drop, place heavy objects, or trample on this product.
- This product is not intended to be used by a person with reduced physical, sensory or mental capabilities.
- Please keep this product away from children.
- Do not cover the product with towels, clothing and other items.
- Do not overcharge this product.
- When fully charged, disconnect the product from the power source immediately.
- If you are not going to use this product for a long time, please disconnect the cable before storing it.
- To charge some portable electronic devices, you may need to set those devices in charge mode first. Refer the corresponding user manual of those devices for confirmation.
- Do not pull the socket cover of the 12V DC Charging Port too hard, the tether could break.

Pure Sine Wave Output

This product generates pure sine wave, which is compatible with AC electric appliance that works with Sinusoidal wave form (power < 2000W). The product is perfect for off-grid power needs or backup power for emergency situations. However, it cannot replace the standard DC or AC power supply for household appliances.

Warranty

Our company provides customers with warranty of 12 months from the date of purchase.

Customer Service: energizer@iittechnology.com

© 2022 EnerGizer. EnerGizer and certain graphic designs are trademarks of EnerGizer Brands, LLC and related subsidiaries and are used under license by Tenshich International Corp.



Made in China