

iENYRID M4PRO S+

iENYRID

enjoy your ride

iENVYRID

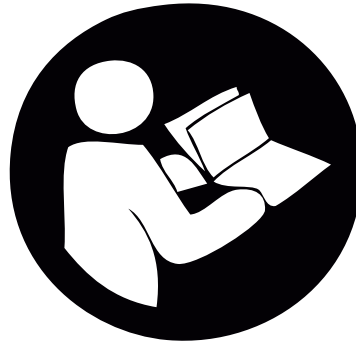

The product is slightly different from the picture, for your safety and the safety of others, please read the instructions before riding.

When using the product, please comply with the laws and regulations in your area. We are not responsible for any claims, liabilities or losses that arise or may arise from the consumer's violation of local laws and regulations.

Catalog

Packing list-----	02
Product introduction-----	03-08
Charging method of electric scooter-----	09
Riding method-----	10-11
Folding and carrying-----	12
Specifications of electric scooter-----	13-14
Safety instructions-----	15-18
Safety tips-----	19-20
Daily care and maintenance-----	21-22

Packing list

Electric Scooter

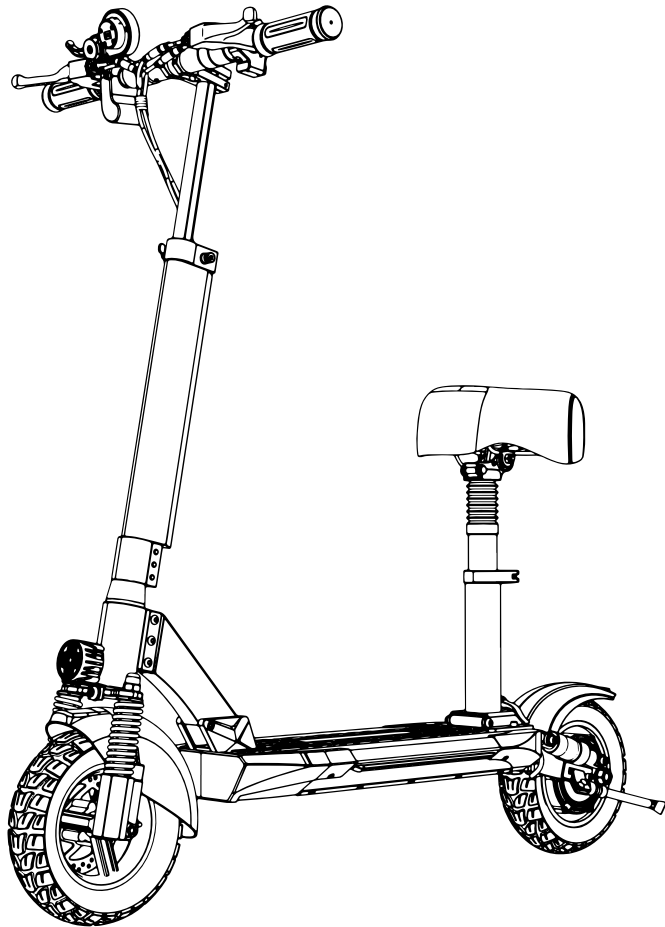

Seat

Accessories :

Charger

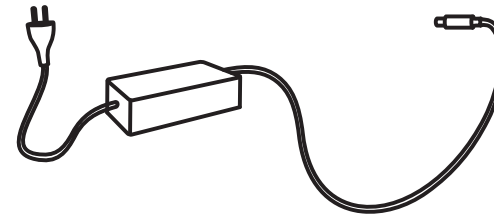

Toolkit

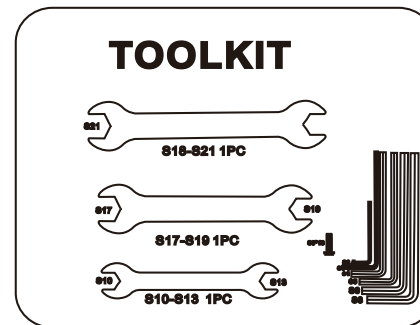

User manual

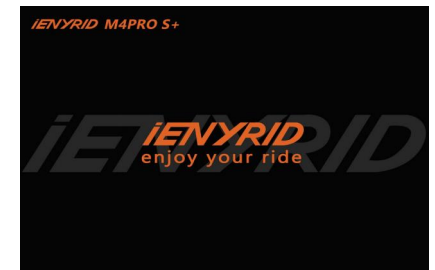

Product introduction

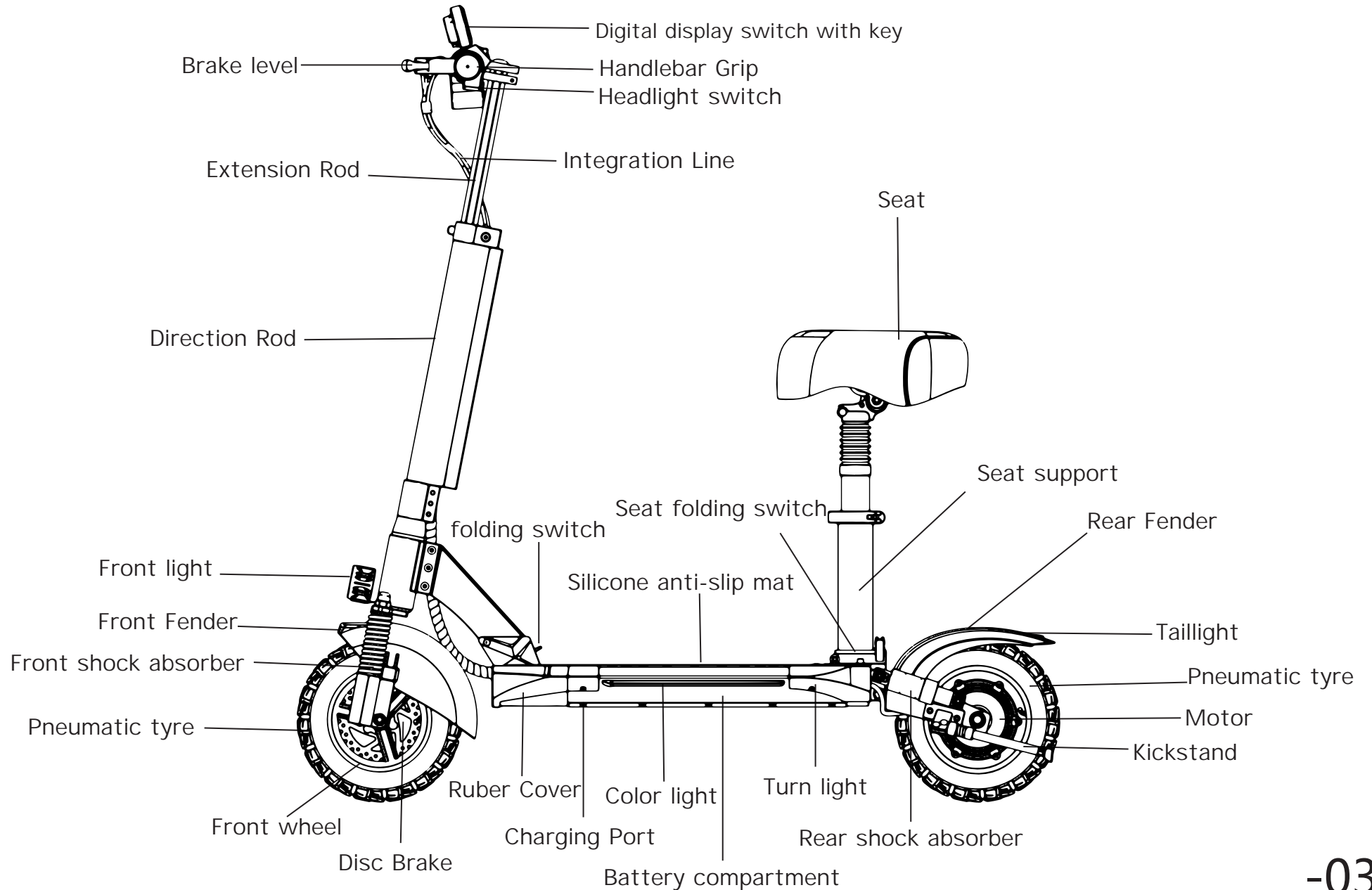

Power switch

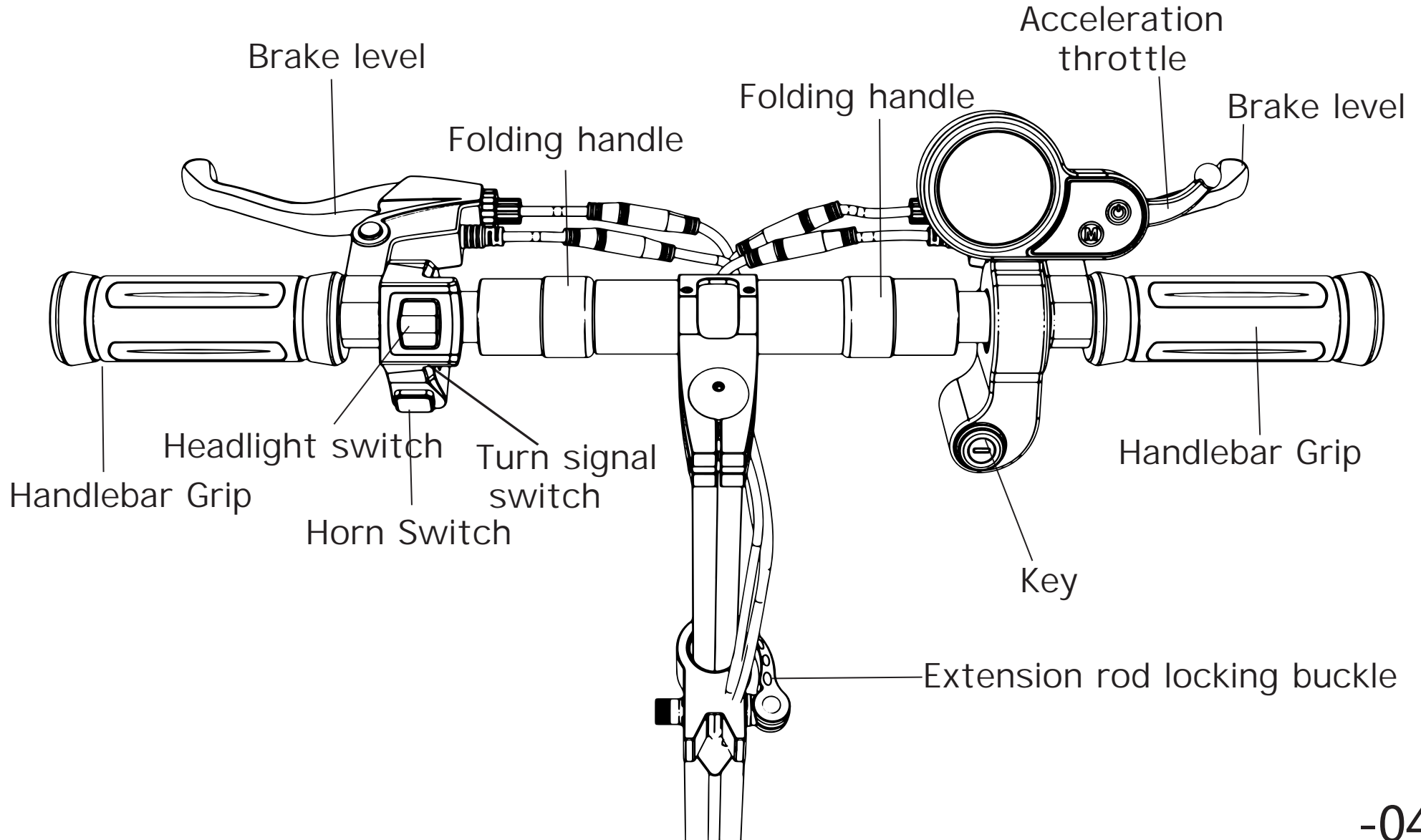

It contains threads that need to be loosened first and pushed outward.

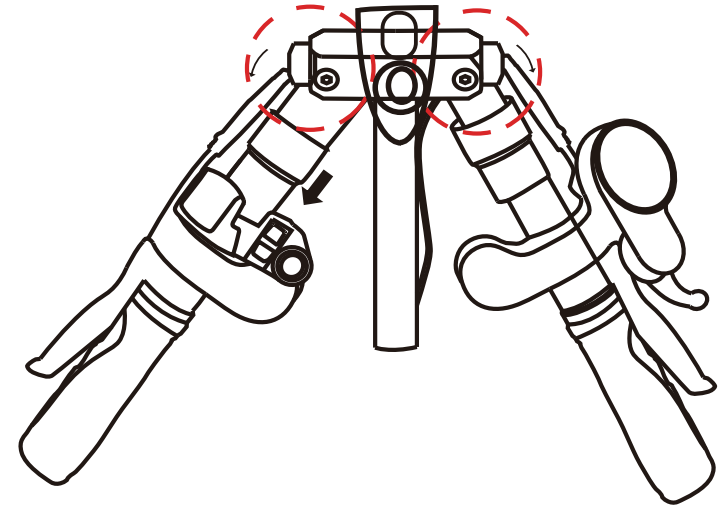
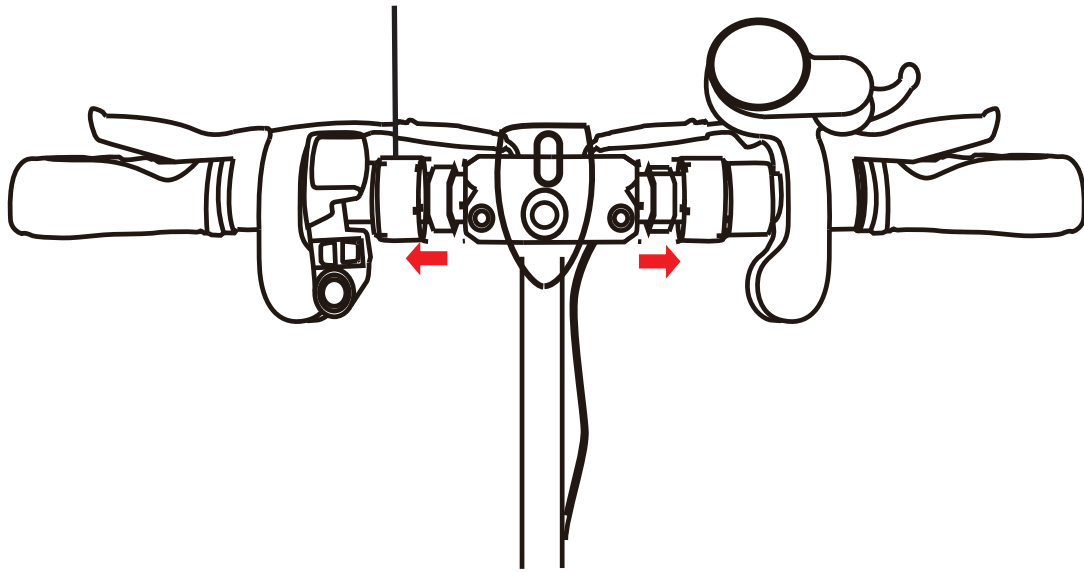

Warm tip: for the convenience of folding, the collar and shaft is not fully tightened. It is a normal phenomenon if there is a gap.

Please rest assured that this will not affect the safety of driving.

If necessary, you can adjust: clockwise adjustment of the threads will loosen the handle, counter clockwise adjustment of the threads will tighten the handle.

Smart Accelerator and Display Dashboard

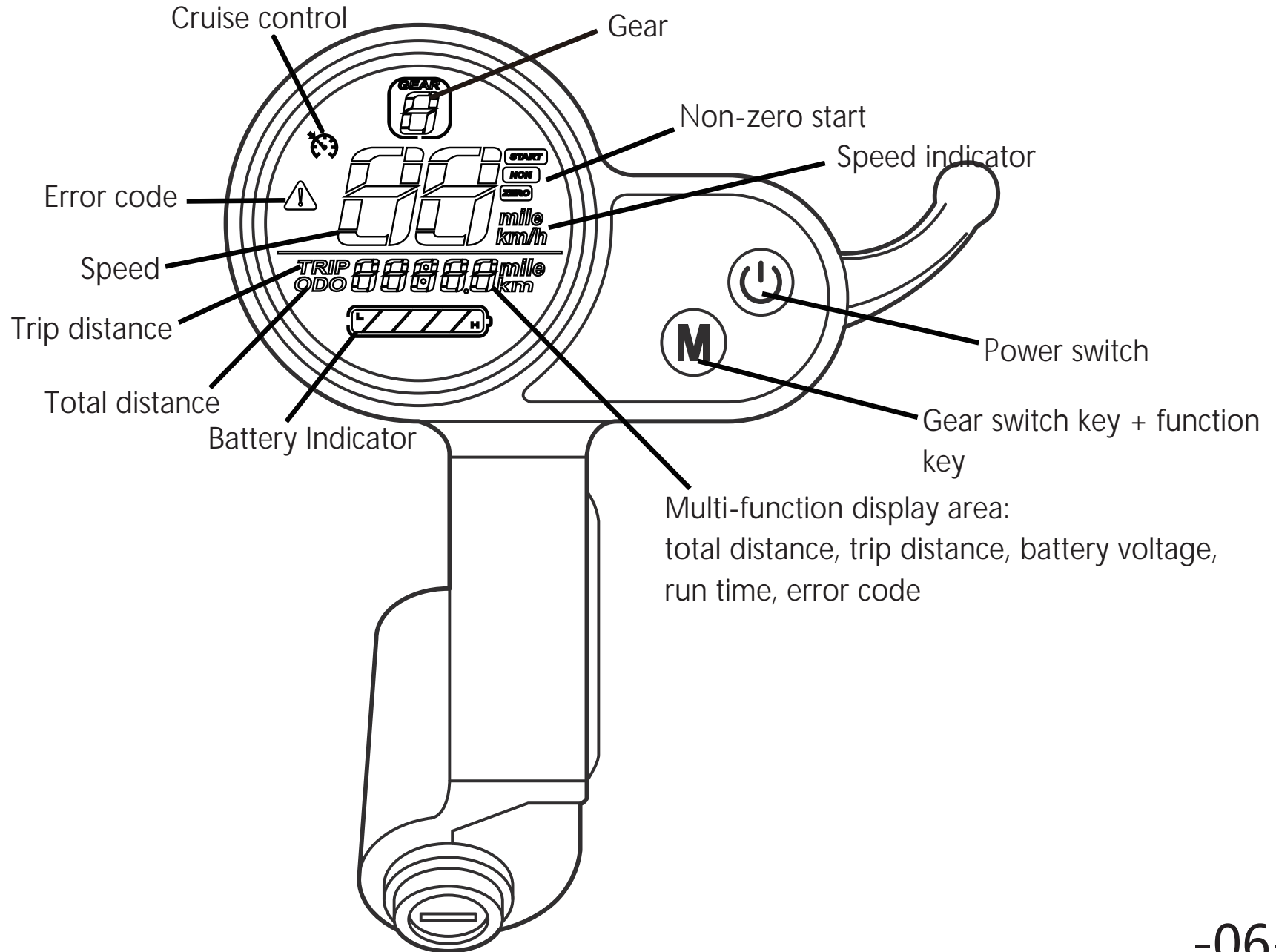

Error display

When there is an error in the electric vehicle, the meter displays the error code and you can check the E-00X error code in a few short presses;

The error list is as follows.

E-001: indicates motor error

E-002: indicates the Speed lever error

E-003: indicates controller error

E-004: indicates brake error

E-005: indicates low voltage protection

E-006: indicates that the controller signal is not received by the display

E-007: indicates that the display signal is not received by the controller

Charging method of electric scooter

When the LED on the charger changes color from red to green, the scooter is fully charged.

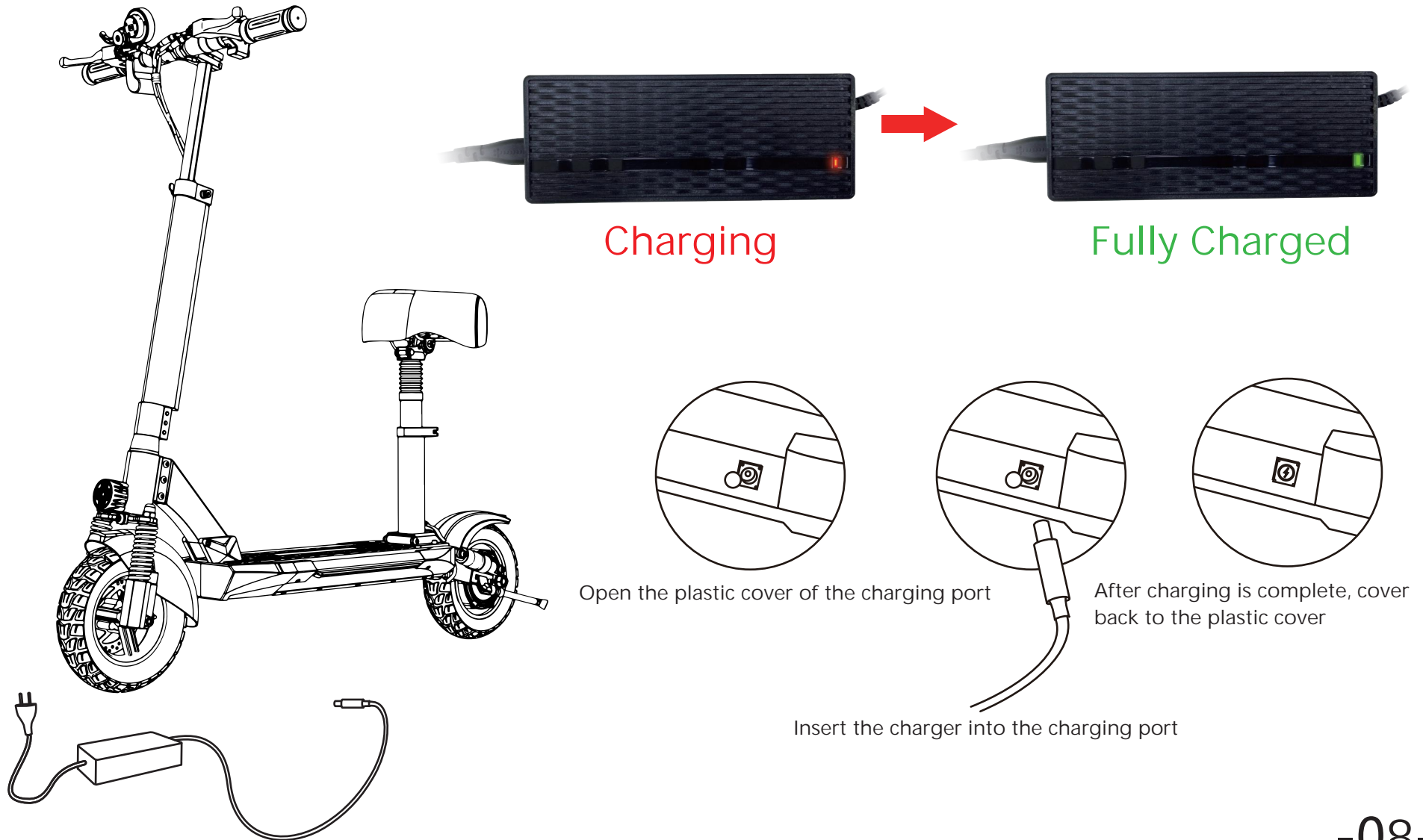

Riding method

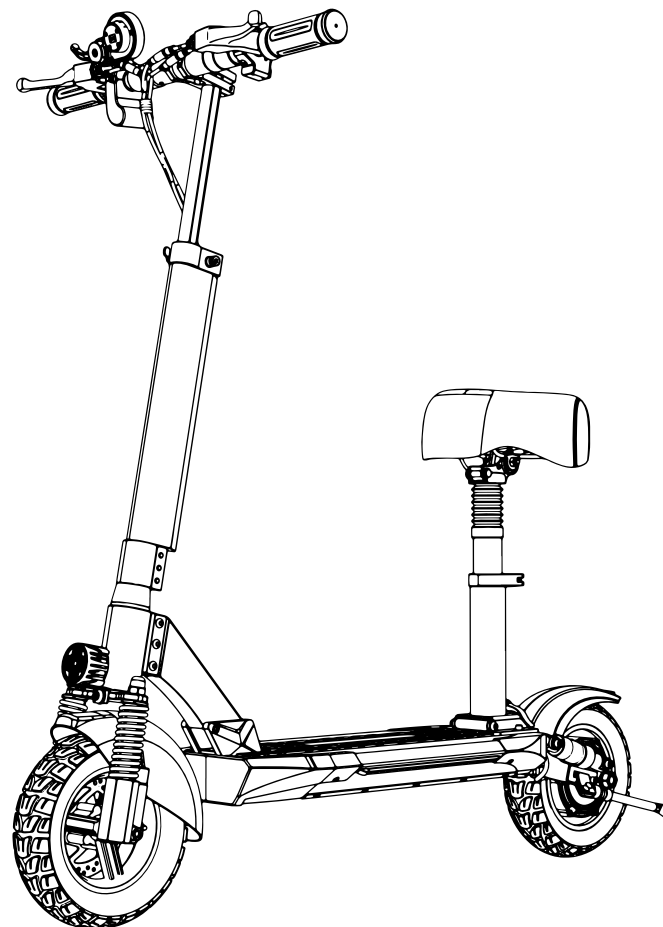
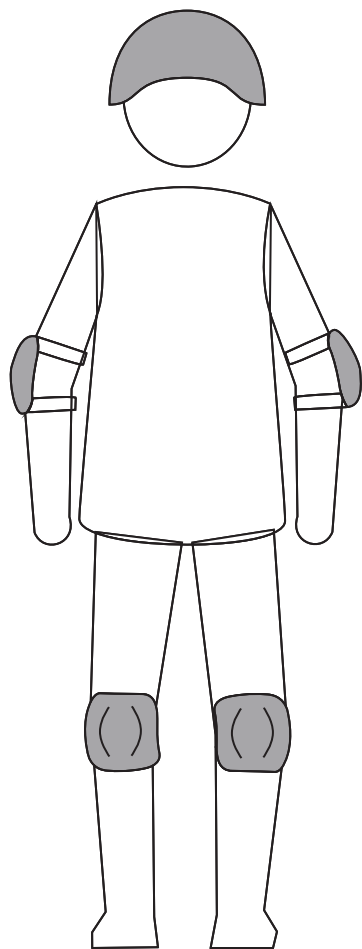

1. Turn on the scooter and check the power indicator



WARNING: Wear a helmet, elbow pads and knee pads when riding.

Please read the manual carefully before use. Do not touch the brake system. For more information, please refer to the instructions.

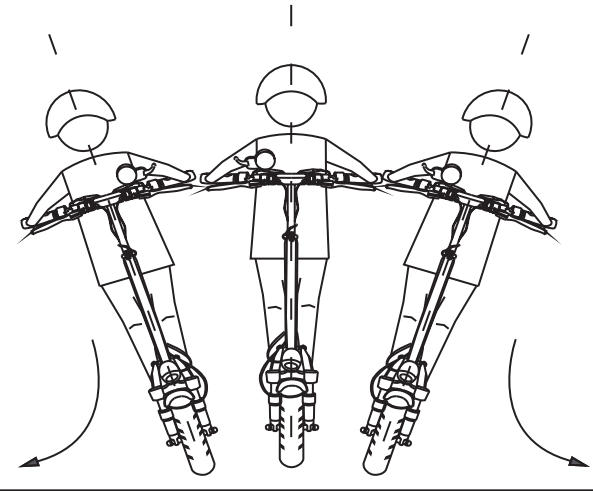
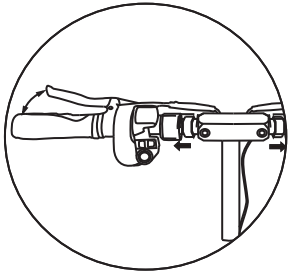
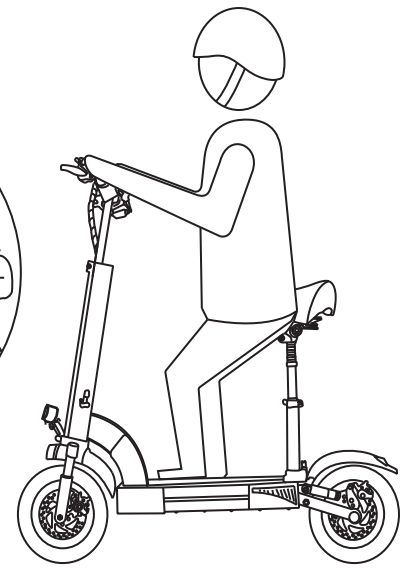
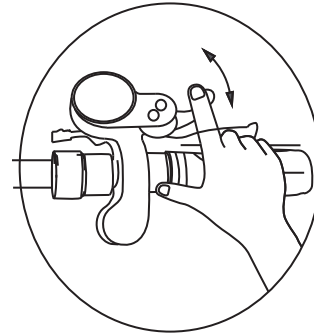
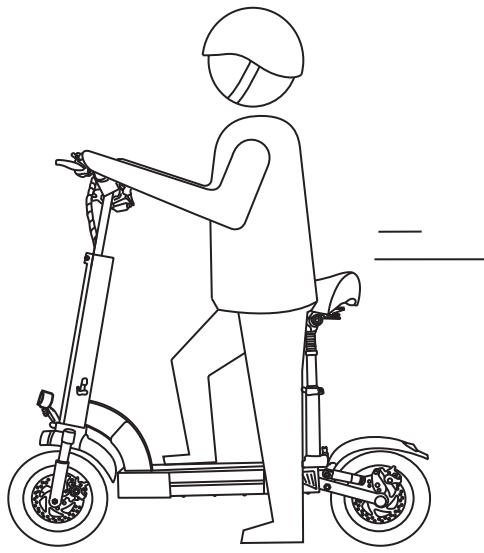

Folding and carrying

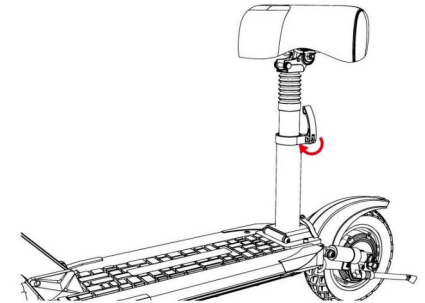
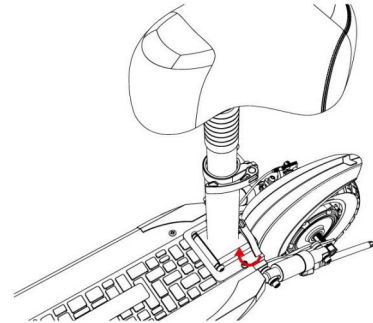
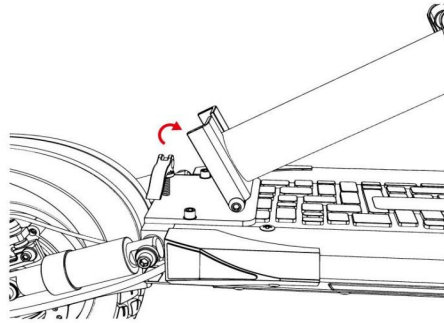
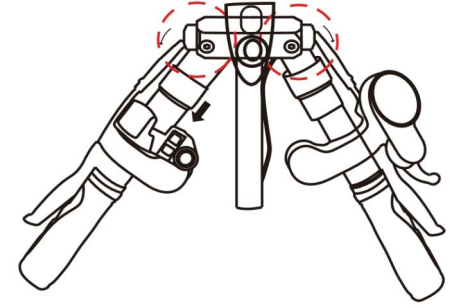
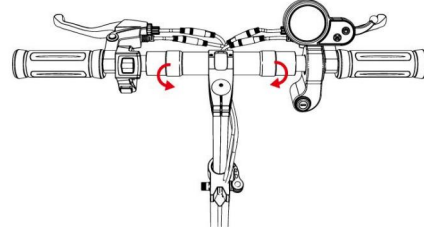
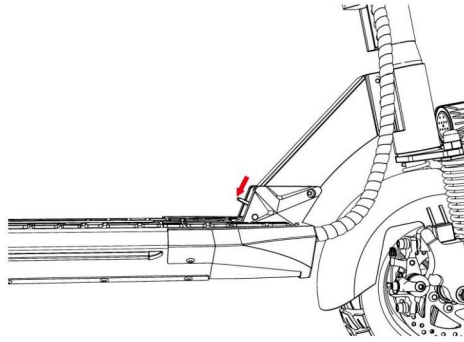
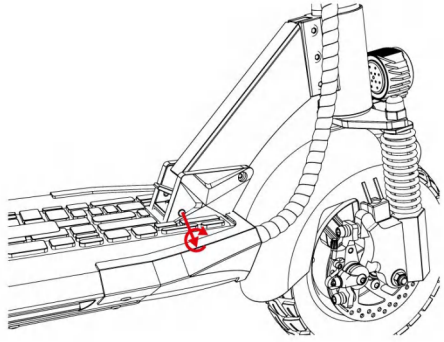



Specifications

Model:	<i>iENYRID M4PRO S+</i>
Package Size:	119.5*26*47.5cm
Gross Weight :	10AH/28.21kg 16AH/29.39KG
Net Weight :	10AH/23.01kg 16AH/24.26KG
Battery :	48V 10AH/16AH
Voltage :	48V
Motor Power :	800W
Tires :	10" off-road pneumatic tires
Max Load :	150KG
Frame Material :	Aluminum alloy
Charging Time :	6-8H
Brake System :	Disc brake + Electronic brake
Max. Speed :	45KM/H 1-3 adjustable gears
Range :	10AH(25-35KM) 16AH(30-50KM)

Storage Temperature :	1 month : -20 - 60 (-4~140°F) 3 months : -20 - 45 °C (-4~113°F) 1 year : -20 - 20 °C (-4~68°F)
Battery Type :	18650 Lithium battery
Working Temperature :	-10 ~ 40 °C (14~104°F)
Charging Temperature :	10 ~ 40 °C (50~104°F)
Storage Humidity :	5% ~ 95%

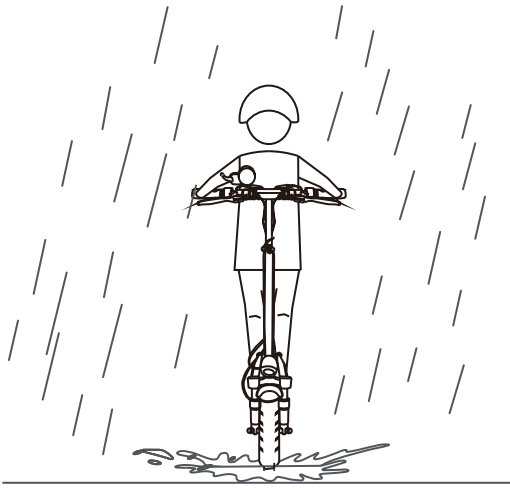
Note: Data and specifications may vary depending on the model.



 Do not ride in the rain

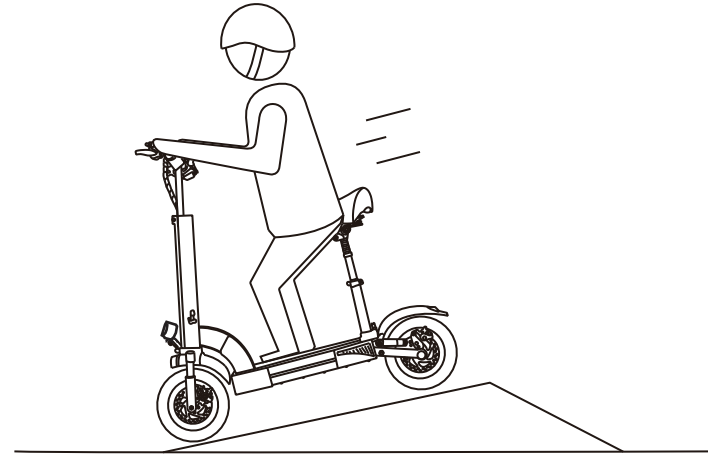

 Do not accelerate when going downhill

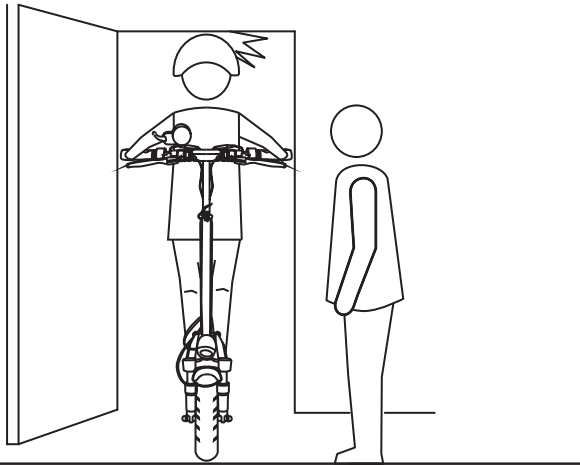

 Watch out doors, elevators and other overhead obstacles

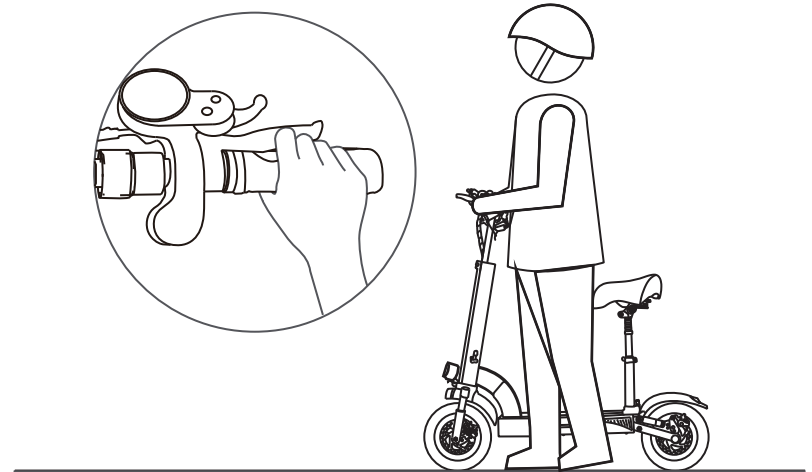

 Do not accelerate when pushing

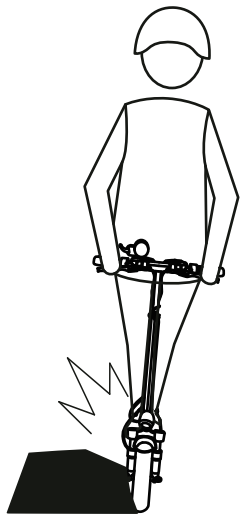

Be careful to avoid obstacles

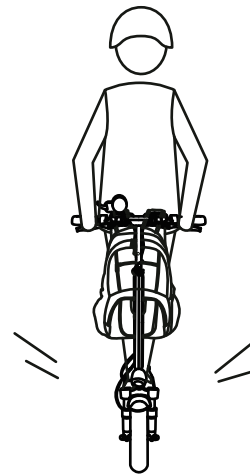

Do not hang bags or other heavy objects on the handlebars

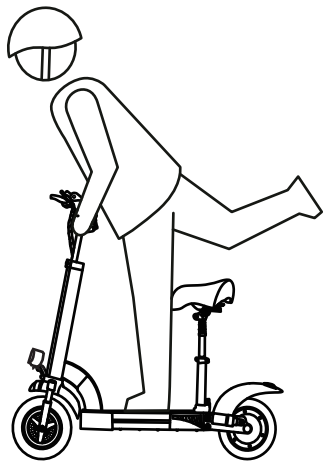

Do not ride on one foot

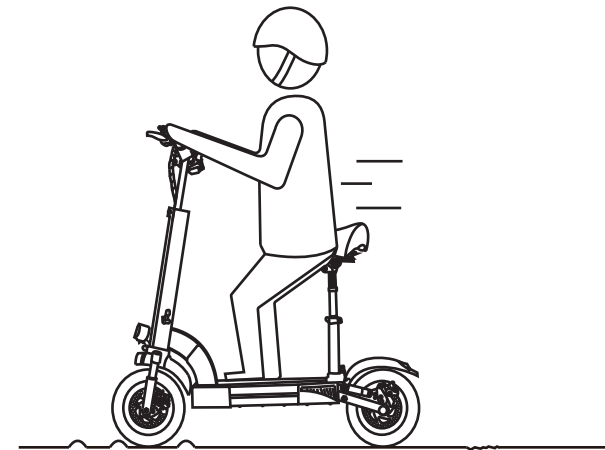

Keep your speed between 5-10 km/h when crossing speed bumps, tight sections, bumpy roads or other uneven surfaces.

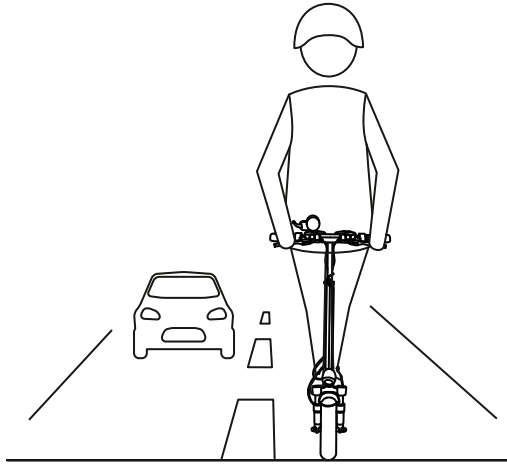

Do not ride in the motorway

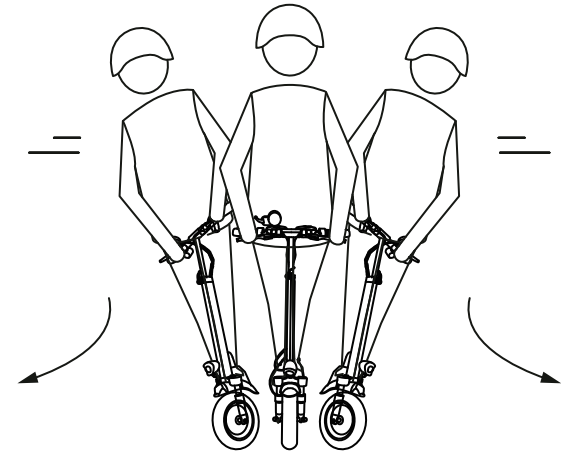

Do not turn your handlebars violently when riding at high speed



Do not ride over puddles or any other (water) obstacle. In this case, reduce your speed and go around the obstacle

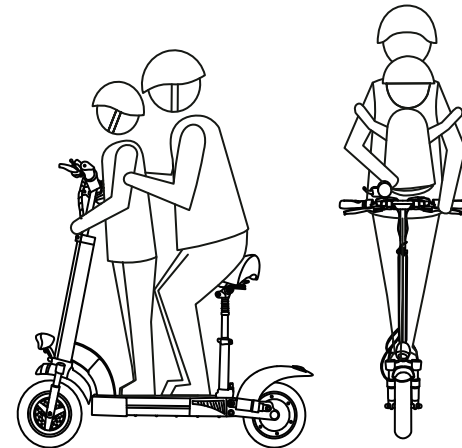

Do not ride with anyone else (including children)

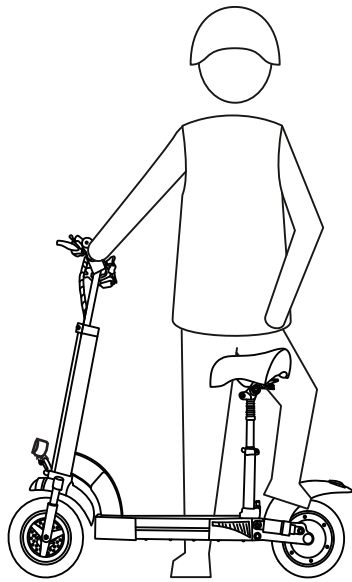

Do not put your feet on the rear fender

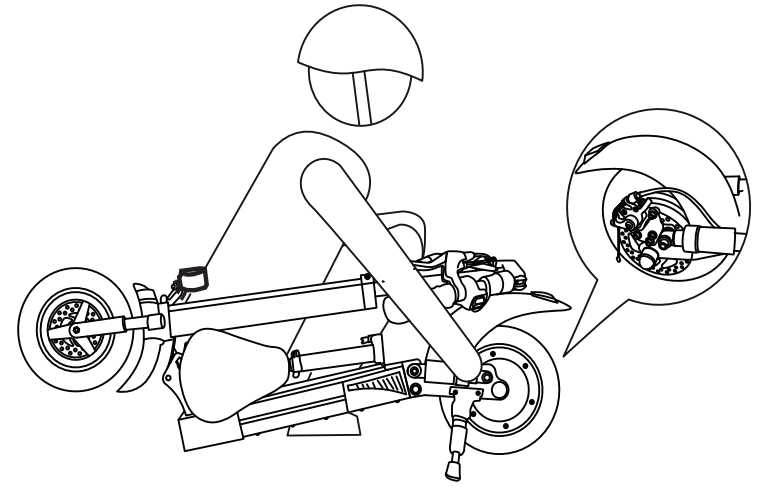

Do not touch the disc brakes

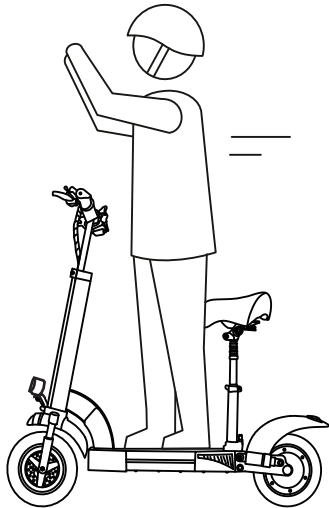

Do not take your hands off the handlebars while riding

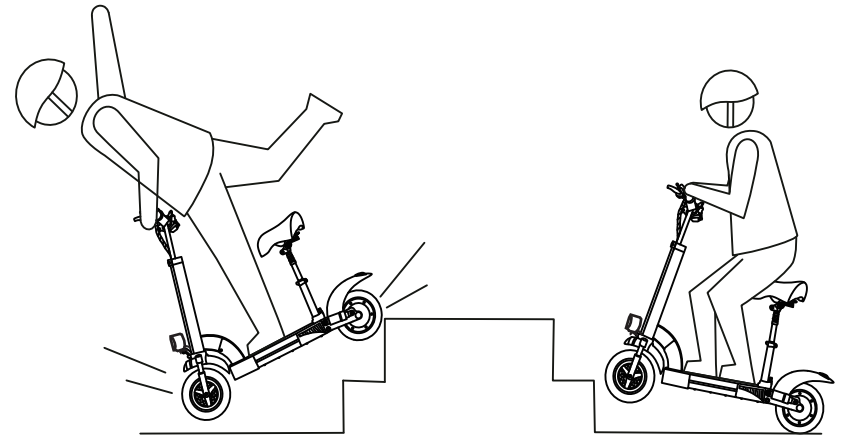

Do not try to go up and down stairs and jump over obstacles

Safety tips

1. Scooters are intended for riders 16 years of age and older. Do not ride a scooter if you have reduced physical, sensory or mental abilities. Riders who are lack of experience or knowledge should drive with caution.
2. This electric scooter is a recreational device. However, once it is in public area, it is considered to be a vehicle and is subject to any risks associated with vehicles. For your safety, please follow the instructions in the manual and the traffic laws set by the government and regulatory agencies.
3. Also, you should understand that risks can not be completely avoided because others may violate traffic laws and drive carelessly. The faster a scooter goes, the longer it takes to stop. On smooth surfaces, scooters may slip, lose their balance, or even cause falls. Therefore, you must exercise caution and maintain the proper speed and distance especially if you are not familiar with the area.

4. Riding at high speed or speed that is not appropriate for the current conditions (adverse weather conditions, poor ground conditions, etc.) may result in potential loss of stability or loss of control. To reduce any risk, you must follow all instructions in this user manual. Be careful when folding and unfolding the product, it can fall off and cause injury.

5. Inspect the scooter before each use. When you notice loose parts, low battery alarms, tire leaks, excessive tire wear, strange noises, errors and other abnormalities, stop riding immediately and seek professional support.

6. When riding a scooter, you need to hold the handlebars with both hands to avoid shaking and falling.

7. Always place the scooter on its stand on a flat and stable surface.

Do not place the scooter with the front side down, as the stand may close and tip the machine.

Daily care and maintenance

Cleaning and storage

If you see a stain on the scooter body, wipe it off with a damp cloth. If the stain doesn't come off, smear some toothpaste, brush it off with a toothbrush, and then wipe it off with a damp cloth. If you see scratches on the plastic parts, polish them with sandpaper or other abrasive material.

Note

Do not use alcohol, gasoline, kerosene or other corrosive and volatile chemical solvents to clean the scooter as this may cause serious damage.

Do not use high pressure water jets to clean the scooter.

During cleaning, make sure the scooter is off, unplug the charging cable and close the rubber cover, as water leakage may cause electric shock or other major problems.

When the scooter is not in use, keep it indoors in a dry and cool place. Do not leave it outside for long periods of time. Excessive sunlight, excessive heat and cold will accelerate tire deterioration and affect the life of the scooter and battery.

Maintenance :

Always charge the battery before it runs out of power to extend the life of the battery. The battery pack performs better at room temperature and less well below 0°C. For example, below -20°C, the riding range is half or less than normal. When the temperature rises, the riding range is restored.

The scooter can only use the original battery and the scooter can only be charged by the original charging adapter included with the scooter. (or a compatible battery model or charging adapter model approved by the manufacturer)

Do not leave the battery in an environment where the ambient temperature is above 50°C or below -20°C

(e.g., do not leave the scooter or battery pack in a sun-drenched vehicle for an extended period of time)

If the scooter is expected to be idle for more than 30 days, keep the battery fully charged and in a dry, cool place.

Remember to recharge the battery every 30 days to protect it from potential damage beyond the limited warranty.

iENYRID
enjoy your ride