

INSTALLATION • STEEL, COPPER & ZINC GUTTERS

Zambelli gutters are available in the half round profile in four sizes with a range of brackets to accommodate all types of eaves. The system is dry jointed without the need for additional silicone sealant.

The gutter range can be connected to the steel pipework system and secured by standard pipe clips. The assembly and installation must be considered individually depending on the project, although general aspects of preparation are common to all as shown below.

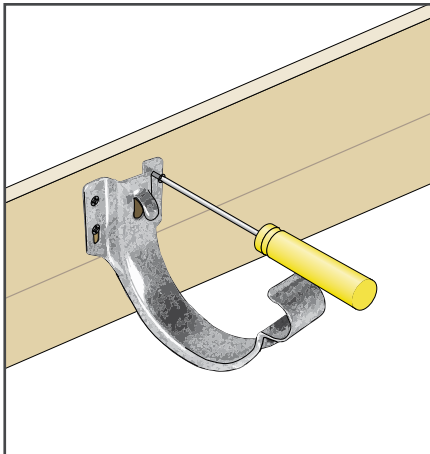

1. Generally position the fascia brackets at 915mm centres, using at least 3 brackets per gutter length. Use 2 screws on both the left and right fixing options (i.e. use 4 screws in total per bracket).

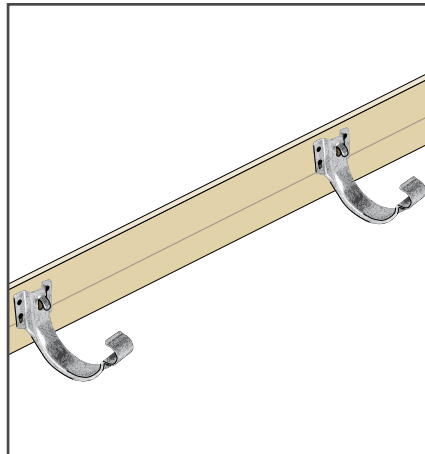

2. Use a string line to set out your fascia brackets along the gutter run allowing for a fall of 1:600 to 1:350 (max).

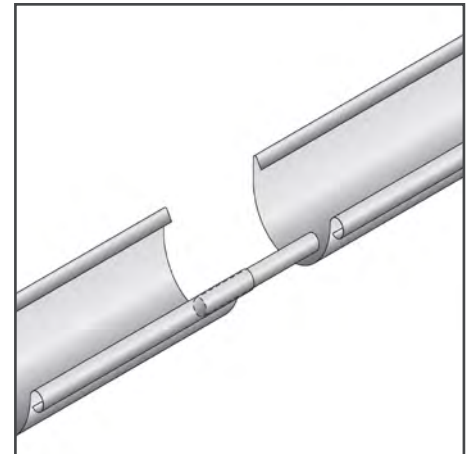

3. A bead connector (comes with the Union connector) is used to join two lengths of gutter. Insert the connector into the front roll of each gutter length. Allow for a 4mm expansion gap.

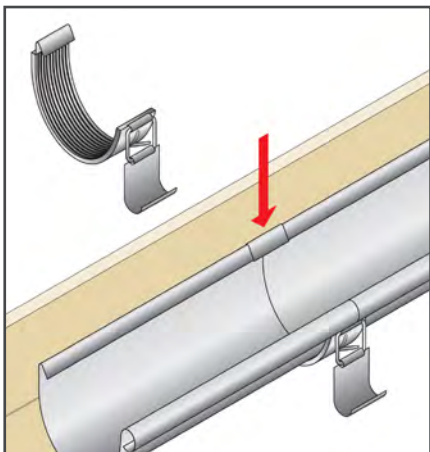

4. An EDPM rubber sealed union connector is used to connect the gutter lengths and angles together. Push open locking tab with thumb by peeling back rubber seal.

Locate the union connector over the rear edge of the gutter. Ensure rubber does not obstruct good fit.

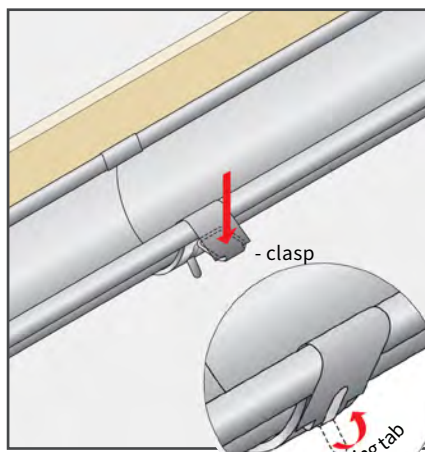

5. Locate the clasp over the front roll edge of the gutter. Pull union tight to the gutter and push the clasp down to squeeze shut.

N.B. Fold the locking tab over and press flush to **fully secure the clasp**.

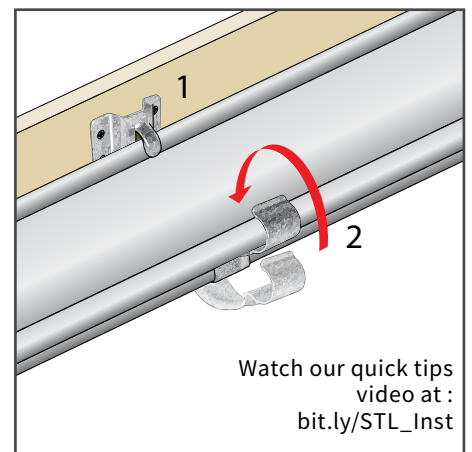

6. Locate the back of the fascia bracket over the rear edge of the gutter first, then pull the front of the fascia bracket up and over the front roll of the gutter. If you're finding this a bit of a struggle, use the bead connector (or other suitable tool) to open/raise the rear 'tab' of the fascia bracket a little.

Watch our quick tips video at : bit.ly/STL_Inst

N.B. Wear gloves when installing Plain Galvanised Steel:

The Plain Galv will dull over time. Touching it without gloves breaks through the oily surface and starts the weathering process earlier in those areas. In a few months the 'weathering' will catch up all over.

Quick tip videos:

The Push-fit stopends: bit.ly/STL_Inst. Simply match the stopend 'ear' to the gutter bead at the front, then 'push' the stopend on. The 'ear' at the rear will finish higher than the rear edge of the gutter.

Glue-in Zinc stopends: bit.ly/Znc_Inst (N.B. only the zinc offers alternatives to push-fit)



INSTALLATION • STEEL, COPPER & ZINC PIPES

Zambelli downpipes are available as a circular profile in 3 sizes with a range of pipe clips and fittings to accommodate all types of installation situations. The downpipes and offsets are push-fit with 'swaged' ends, again for fast and watertight installation.

The assembly and installation must be considered individually depending on the project, although general aspects of preparation are common to all as shown below.

Wrap-around Outlet (★ alternatively use prefab outlets)

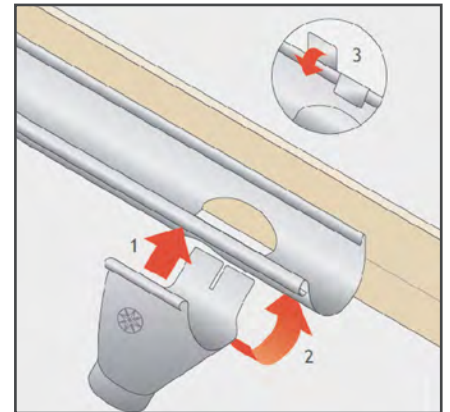
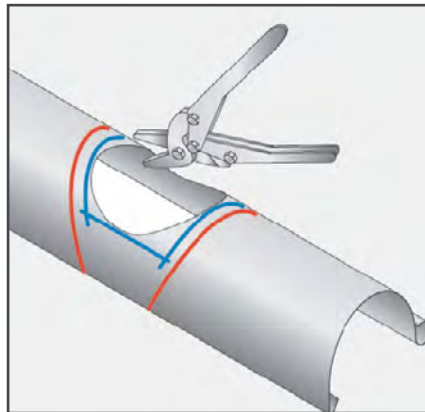
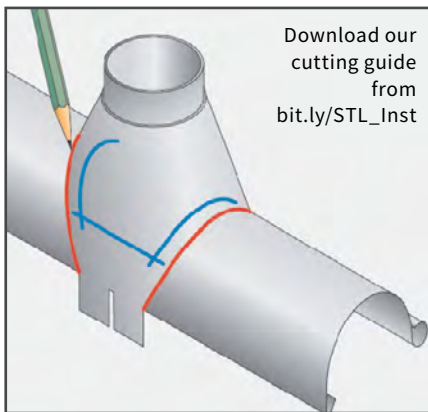

1. When installing a 'wrap around outlet' mark the desired location of the outlet by drawing a line either side of the outlet along its edge. Draw another line 20mm inside of the outer lines and join these inner lines together in an oval. This becomes the line to follow to cut out the hole.
2. Use a hacksaw to make an initial hole in the gutter, and then use a set of tin snips to cut out the inner hole that you have marked out.
3. Attach the outlet to the gutter and fold the rear tabs of the outlet over the rear edge of the gutter, making sure the outlet is aligned correctly to accept the downpipe.

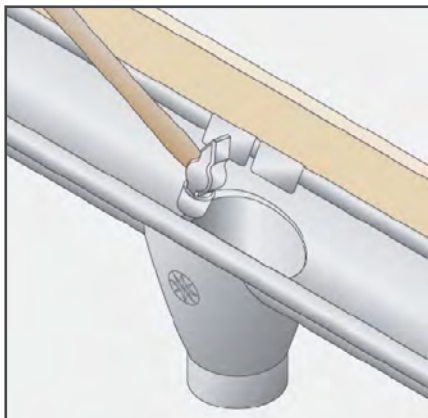

4. Tap the inner rough edges of the hole that was cut in the gutter, down into the outlet, to ensure a smooth flow of water.

Offsets

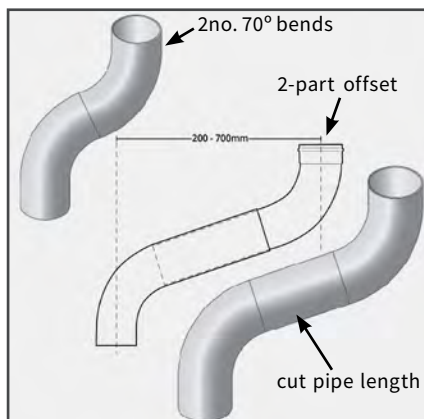

5. Offsets are achieved using either the 60mm fixed offset, 2no. 70° bends, the 2-part variable offset (for up to 700mm) or, for larger projections, by inserting a cut pipe length between the two bends.

N.B. The 2no. bends do NOT require additional connectors when creating longer projections.

Downpipes

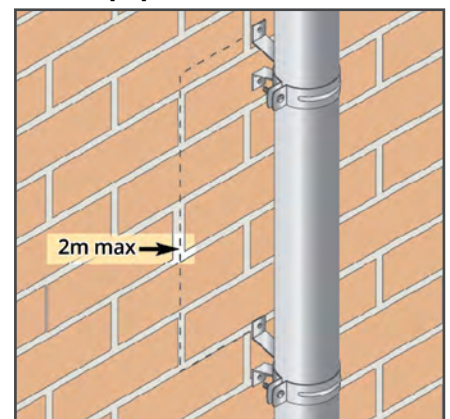

6. Downpipes should be installed using at least 2/no pipe clips per length. Mark out the clips locations and level with a spirit level or plumb line.

Choose either the standard Fixed Depth clip or M10 Boss Adjustable Depth downpipe clip (the standard one for the Copper system)

Open the tightening screw to allow the pipe to be inserted, close the clip and re-tighten, making sure not to over tighten and damage the downpipe.



★ alternatively choose to use prefabricated outlets
don't forget to order additional gutter unions! ←