

Tools Recommended

EN_IMPORTANT, RETAIN FOR FUTURE REFERENCE: READ CAREFULLY.

ASSEMBLY PREPARATION

Please check local building codes regarding footings, location and other requirements before beginning construction. Study and understand this owner's manual of important information and helpful tips for easier and more enjoyable assembly.

Assembly instructions:

Reviewing all instructions and the appropriate information before you begin, make sure following the step sequence carefully for successful results.

Flooring base:

The site must be prepared so that the base of the shed is level all round and checking with a spirit level is required.

The base can be constructed by treated timber or concrete, in order to stop the moisture getting into the shed, The shed is not designed to be built onto lawn directly. Also the ground will get muddy during rainy days.

If a concrete pad is made, it is important that this slopes towards the edges to prevent water ingress. Time must be allowed for any concrete or cement to dry before building the shed on top.

Bases can also be constructed from bricks, blocks, or mounted on a concrete pad.

The bricks or blocks should be cemented onto firm and level concrete footings and the greenhouse frame drilled and screwed to the base.

Parts and Parts List:

Before you start, separate and identify all the parts and hardware to be sure that you have all the necessary parts for your building (refer to the Parts List Page).

Do not attempt to assemble the building if parts are missing because any building left partially assembled may be seriously damaged by light winds.

Safety must be put in the No. 1 position:

1 Select a dry and calm day for your assembly. Team works (Two or more people) are required during the assembly;

2 Wearing safety gloves, eye protection and long sleeves during the assembly to prevent injury; Pay attention to the sharp edge of some parts;

3 Children and pets are not allowed entering into the construction site;

4 Never concentrate your total weight on the roof of the building. When using a step ladder make sure that it is safety;

Care & Maintenance:

1 Keep the shed clean with soft cloth, use water if necessary;

2 Keep the door tracks clear of dirt and other stuff that prevent them from sliding easily.

3 Clean the snow with necessary tools to make sure it is safe to enter into;

Heavy snow may cause collapse, please make sure safety before entering into.

4 The shed is not made for living but storing stuff.

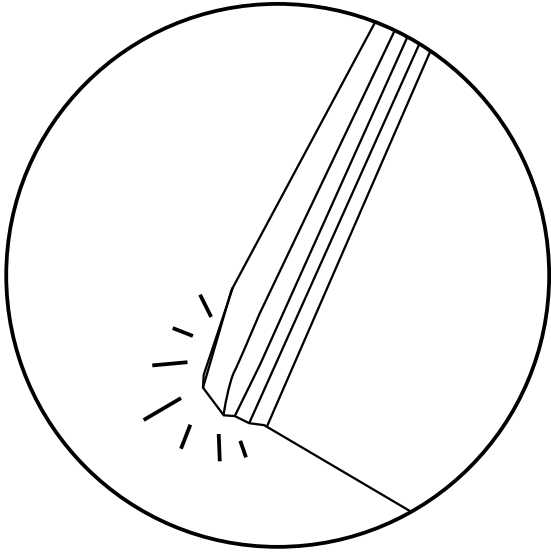

EN_NOTICE: If there is slight bending on the corners

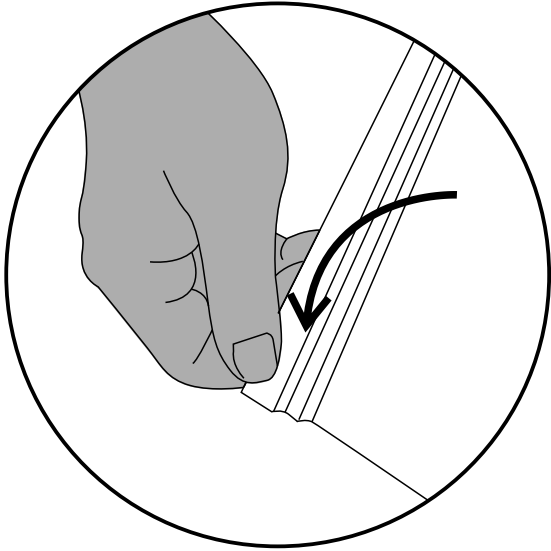



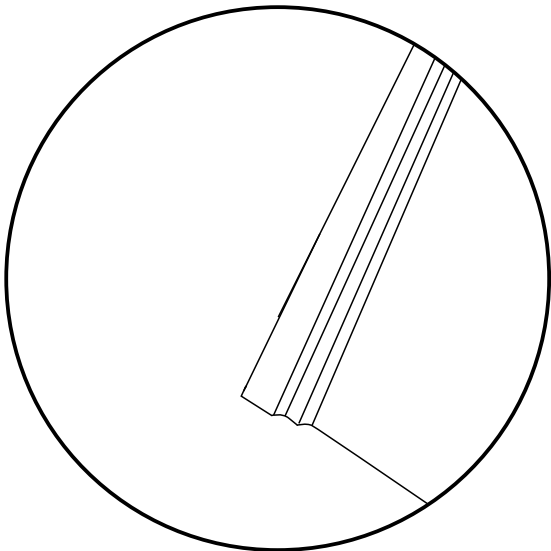



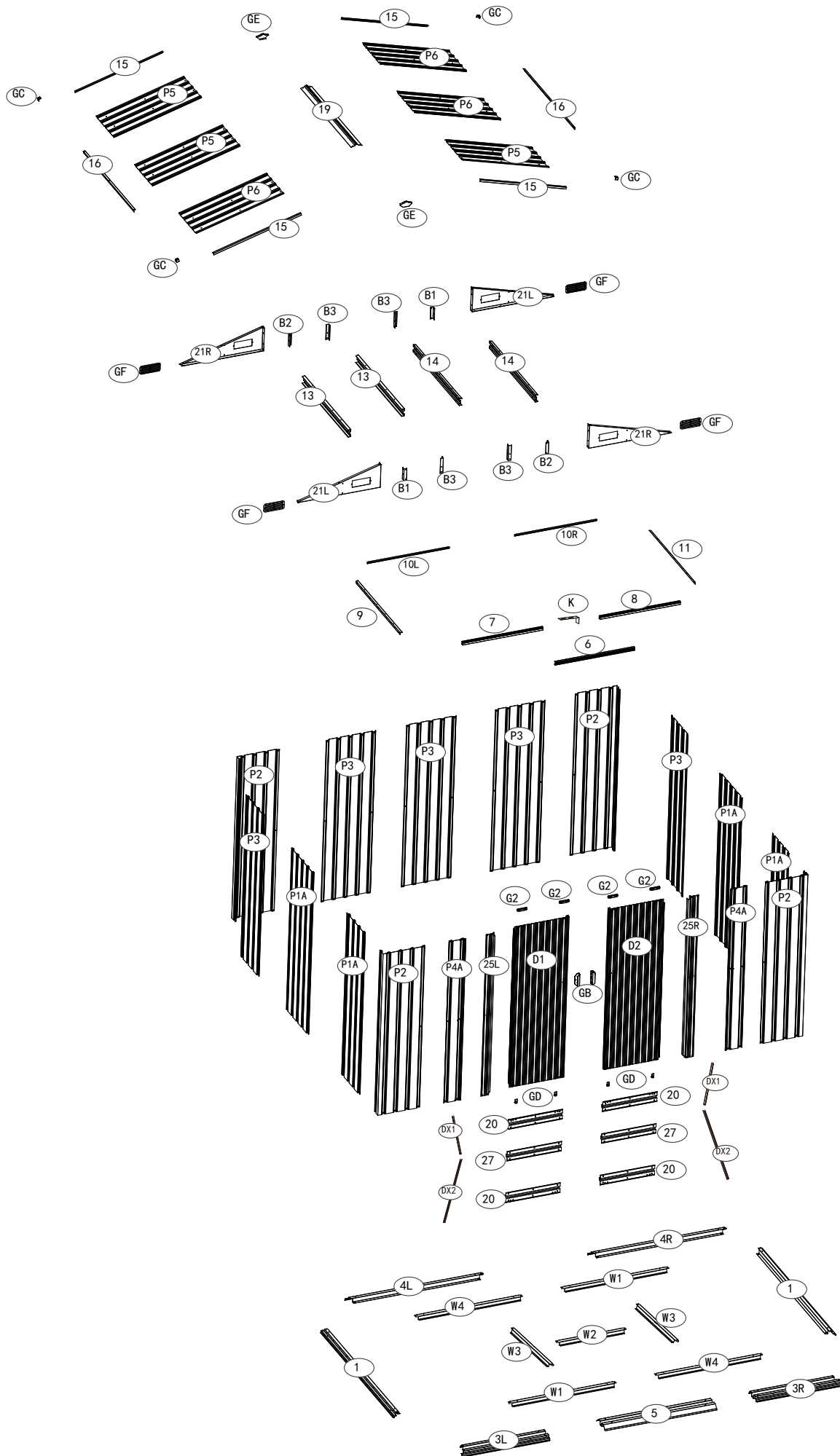







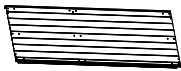











EN_1. Pls wear gloves and stretch the corners slightly until they are flat

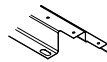
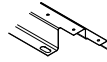



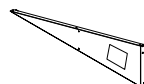
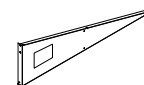



















EN_2. Then the sheets will be normal and there is no effect to the assembling



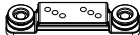

| BOX 1/2 | NO. | PART | Qty. |
|------------|-----|---|------|
| | P1A |  | 4 |
| | P2 |  | 4 |
| | P4A |  | 2 |
| | P3 |  | 5 |
| | 25L |  | 1 |
| | 25R |  | 1 |
| | D1 |  | 1 |
| | D2 |  | 1 |
| | 16 |  | 2 |
| | 19 |  | 1 |
| | B1 |  | 2 |
| | B2 |  | 2 |
| | B3 |  | 4 |

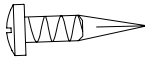

| BOX 2/2 | NO. | PART | Qty. |
|------------|-----|---|------|
| | P5 |  | 3 |
| | P6 |  | 3 |
| | 13 |  | 2 |
| | 14 |  | 2 |
| | 1 |  | 2 |
| | 4L |  | 1 |
| | 4R |  | 1 |
| | 3L |  | 1 |
| | 3R |  | 1 |
| | 5 |  | 1 |
| | 21L |  | 2 |
| | 21R |  | 2 |
| | W1 |  | 2 |
| | W2 |  | 1 |
| | W3 |  | 2 |
| | W4 |  | 2 |

| BOX 2/2 | NO. | PART | Qty. |
|------------|-----|---|------|
| | 6 |  | 1 |
| | 7 |  | 1 |
| | 8 |  | 1 |
| | 20 |  | 4 |
| | 27 |  | 2 |
| | 15 |  | 4 |
| | 9 |  | 1 |
| | 11 |  | 1 |
| | 10L |  | 1 |
| | 10R |  | 1 |
| | DX1 |  | 2 |
| | DX2 |  | 2 |
| | GF |  | 4 |
| | K |  | 1 |

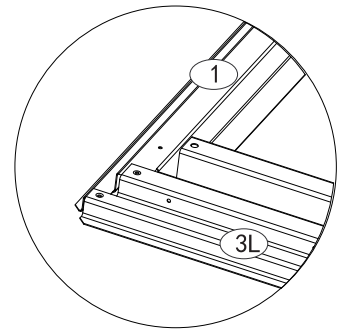
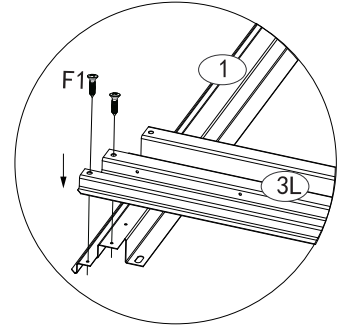
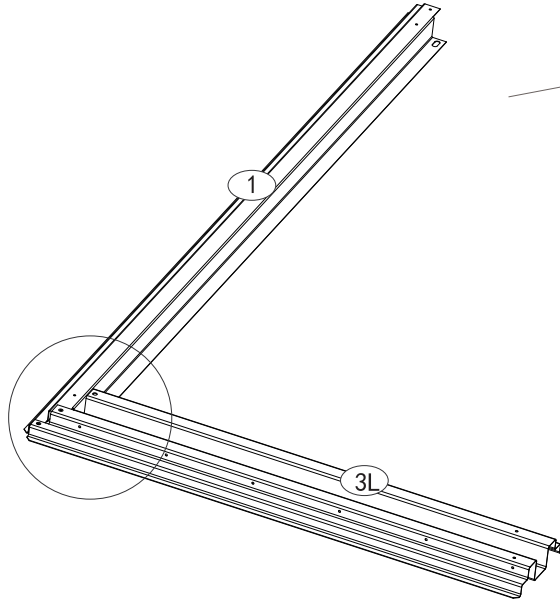

| BOX 2/2 | NO. | PART | Qty. |
|------------|-----|---|------|
| | GE |  | 2 |
| | GC |  | 4 |
| | G2 |  | 4 |
| | GB |  | 2 |
| | GD |  | 4 |
| | F1 |  M4x10 | 204 |
| | F2 |  M4x10 | 102 |
| | F3 |  5x16 | 8 |
| | S2 |  Φ5 | 288 |
| | S1 |  Φ5 | 142 |

| PART | NO. | Qty. |
|---|-----|------|
|  | 3L | 1 |
|  | 1 | 1 |
|  | F1 | 2 |



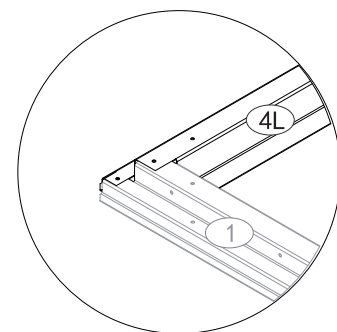
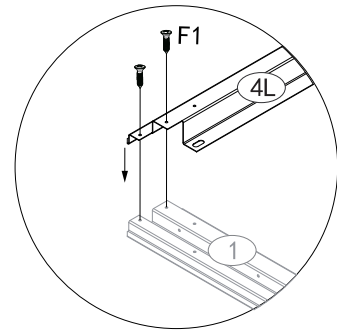
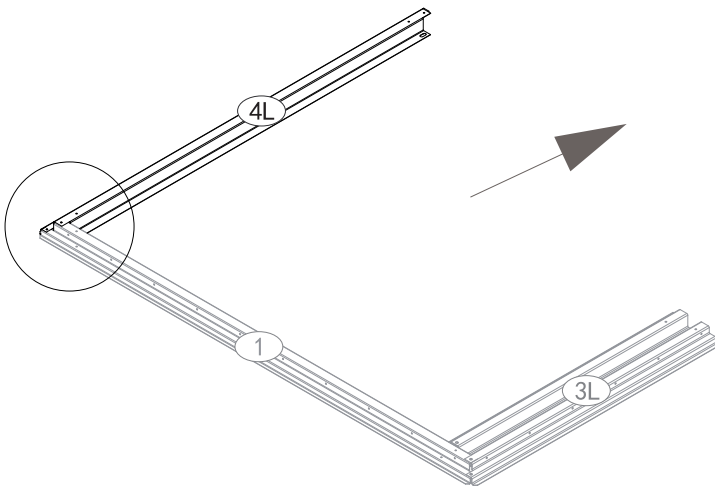

| PART | NO. | Qty. |
|---|-----|------|
|  | 4L | 1 |
|  | F1 | 2 |



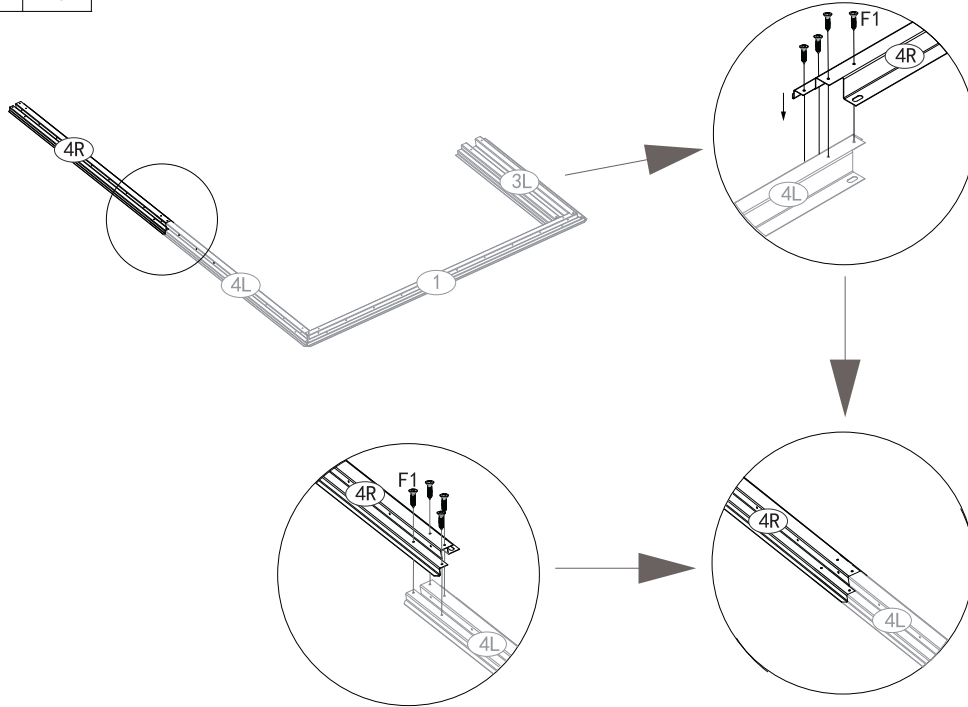

| PART | NO. | Qty. |
|---|-----|------|
|  | 4R | 1 |
|  | F1 | 4 |



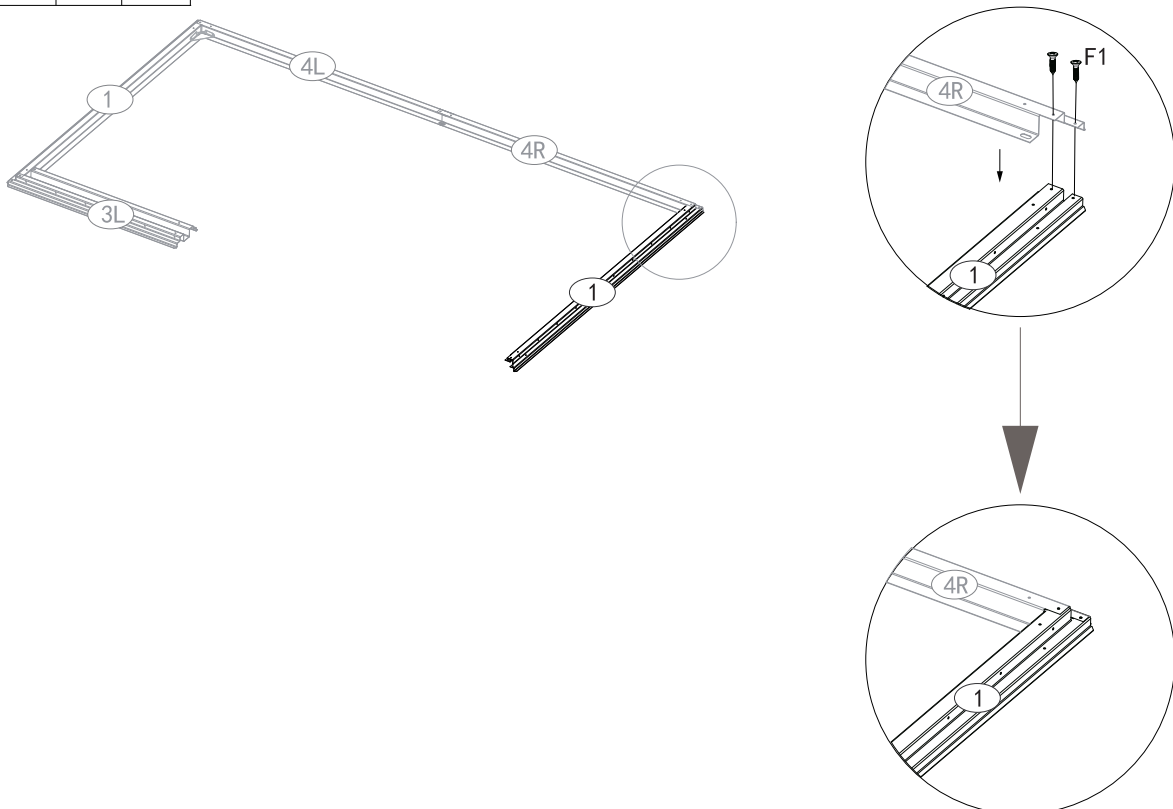

| PART | NO. | Qty. |
|---|-----|------|
|  | 1 | 1 |
|  | F1 | 2 |



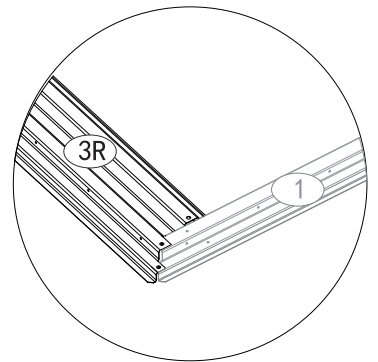
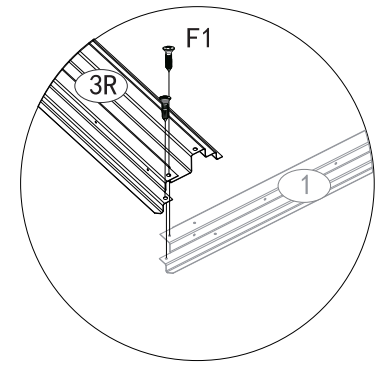
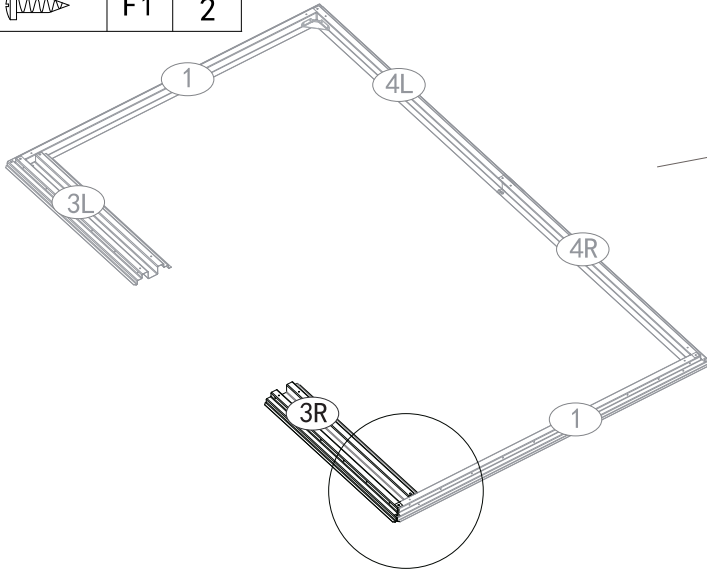



| PART | NO. | Qty. |
|---|-----|------|
|  | 3R | 1 |
|  | F1 | 2 |

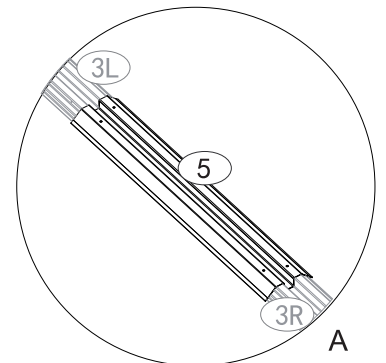
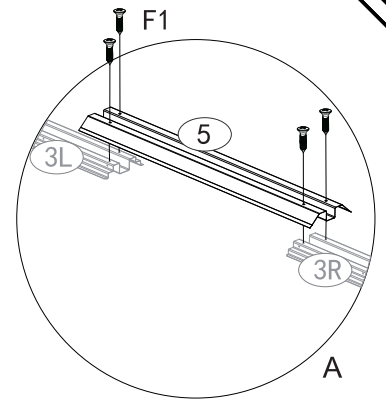
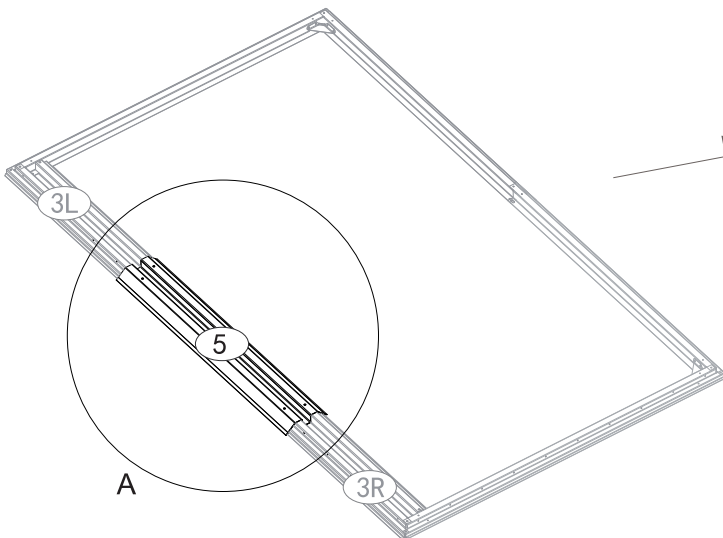

| PART | NO. | Qty. |
|---|-----|------|
|  | 5 | 1 |
|  | F1 | 4 |

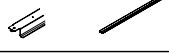

| NO. | PART | Qty. |
|-----|---|------|
| W1 |  | 2 |
| W2 |  | 1 |
| W3 |  | 2 |
| W4 |  | 2 |
| F1 |  | 14 |

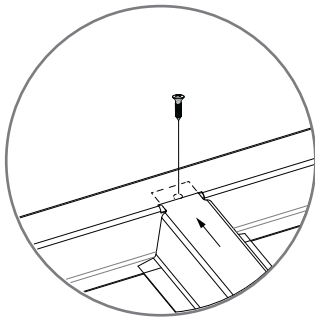
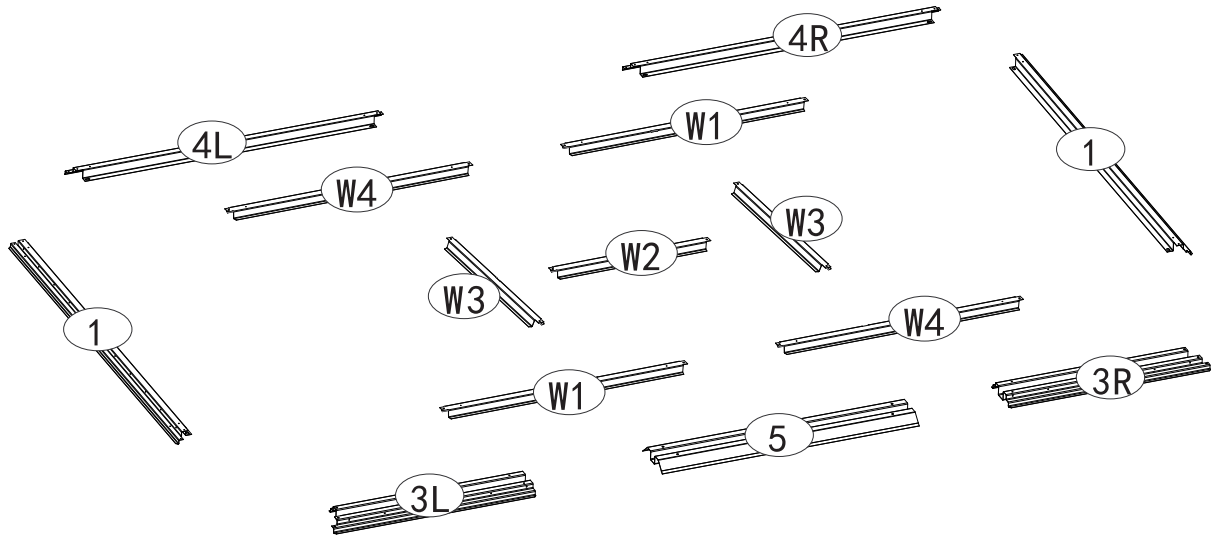

A

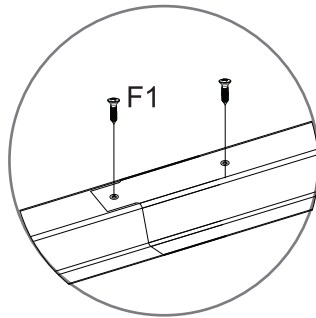

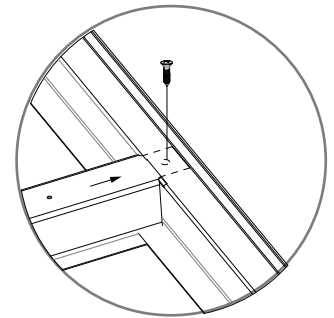

B



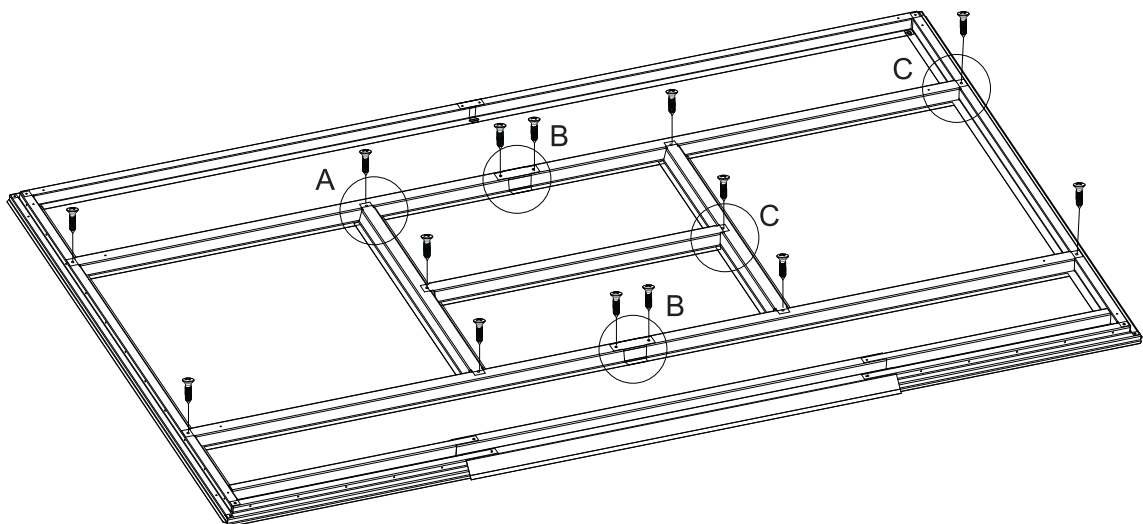

C

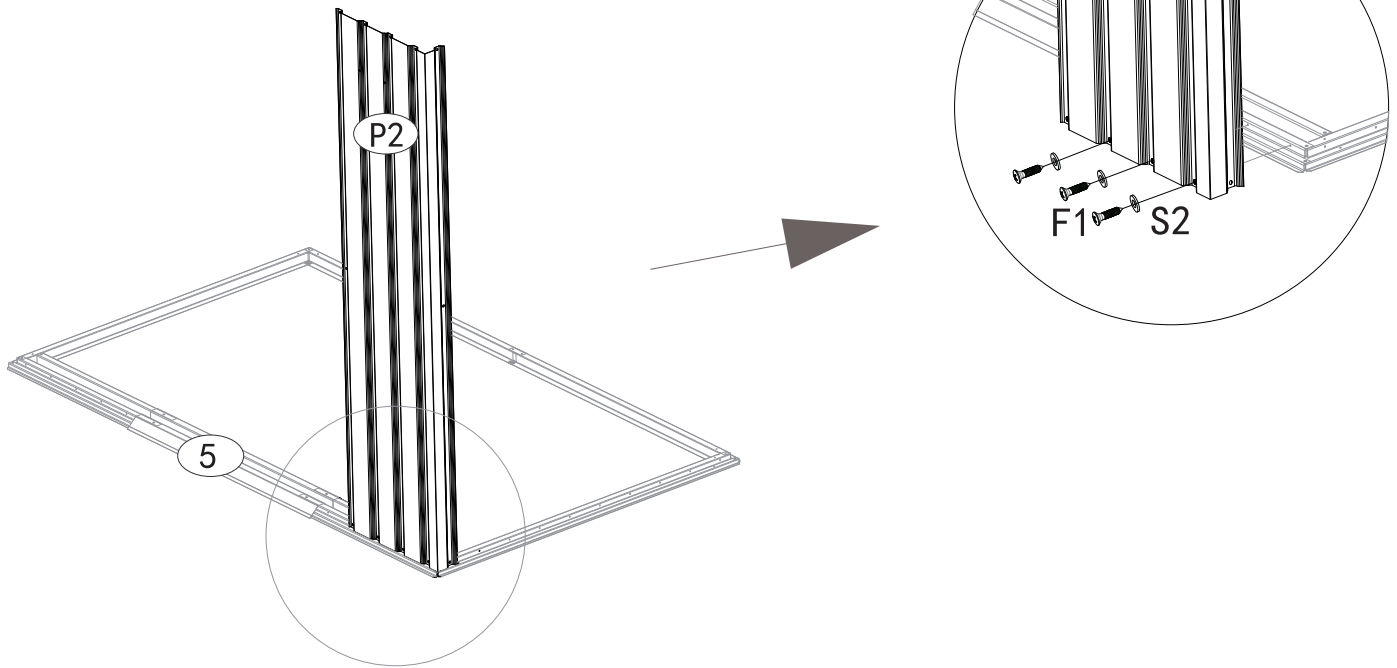

| PART | NO. | Qty. |
|---|-----|------|
|  | P2 | 1 |
|  | F1 | 3 |
|  | S2 | 3 |



| PART | NO. | Qty. |
|---|-----|------|
|  | P2 | 3 |
|  | F1 | 9 |
|  | S2 | 9 |

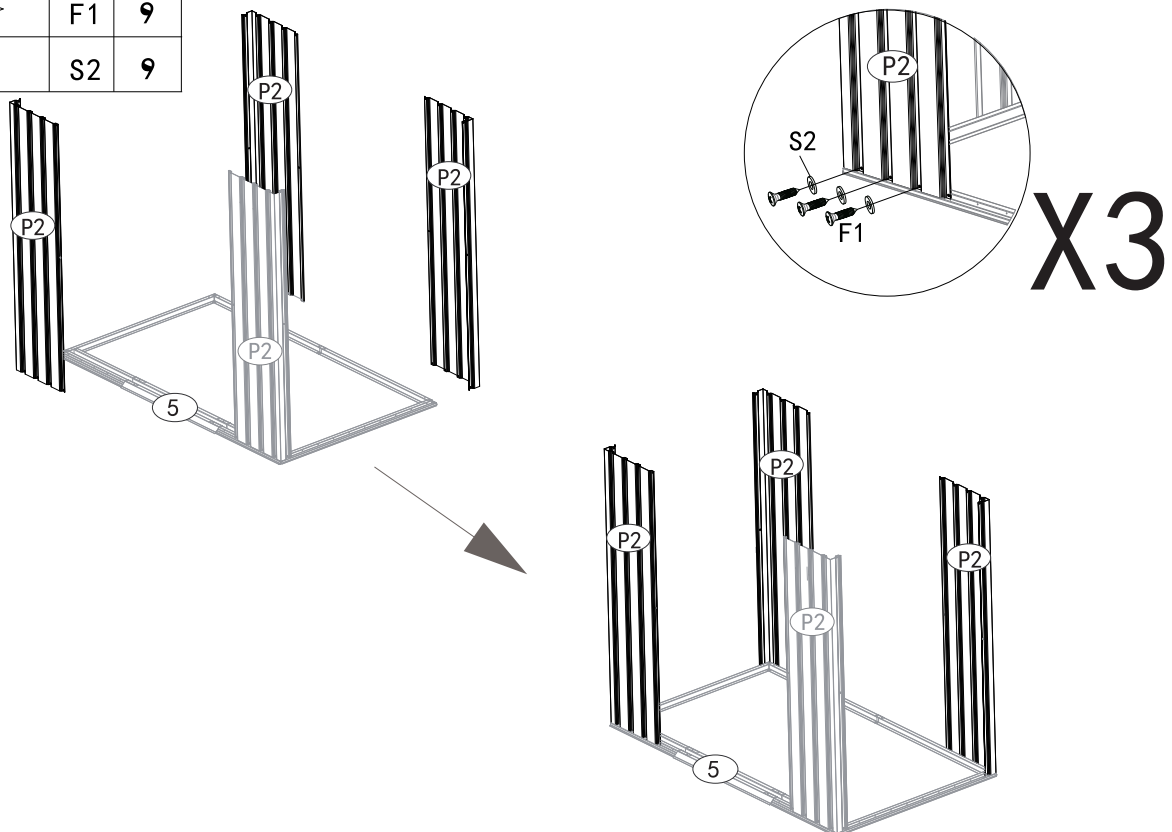



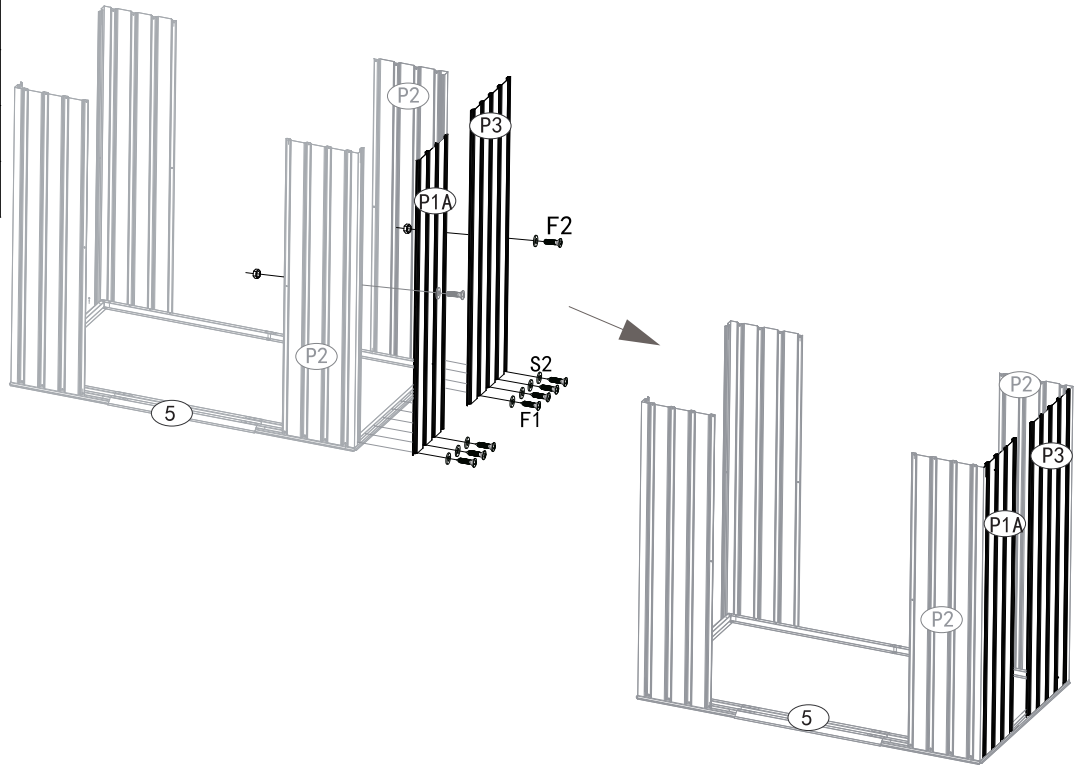

| PART | NO. | Qty. |
|------|-----|------|
| | P1A | 1 |
| | P3 | 1 |
| | F2 | 2 |
| | F1 | 7 |
| | S2 | 7 |

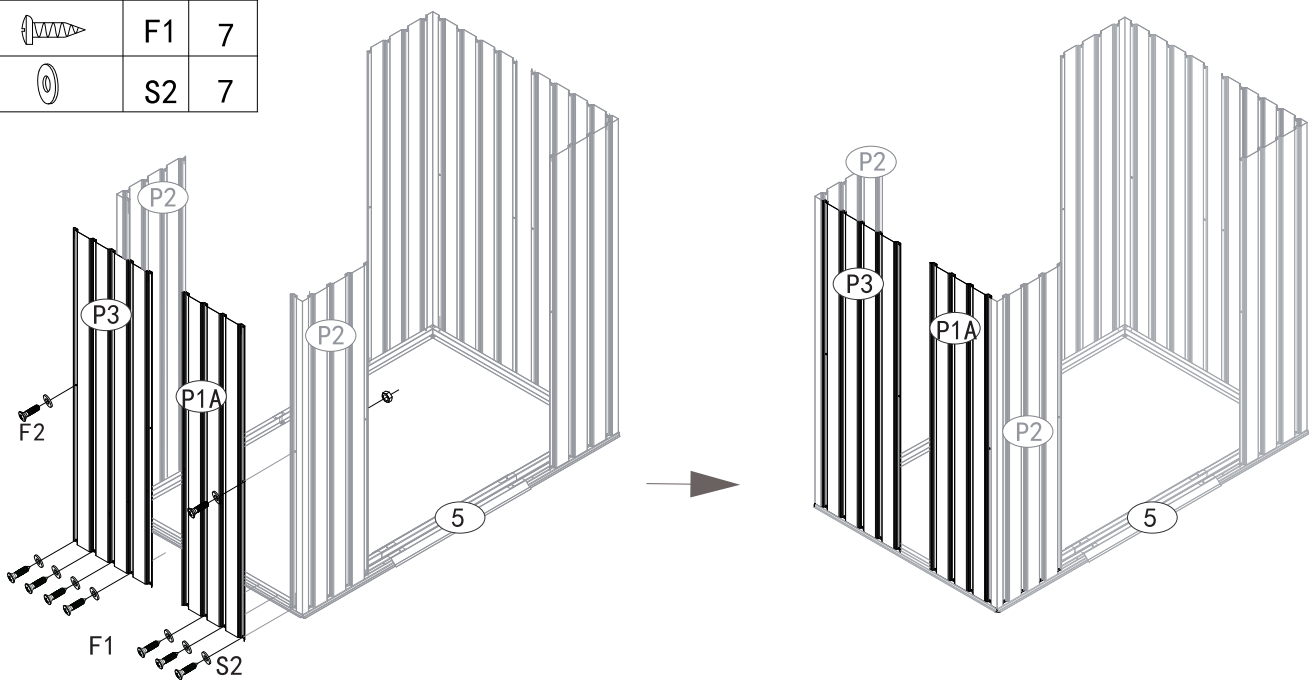



| PART | NO. | Qty. |
|------|-----|------|
| | P1A | 1 |
| | P3 | 1 |
| | F2 | 2 |
| | F1 | 7 |
| | S2 | 7 |



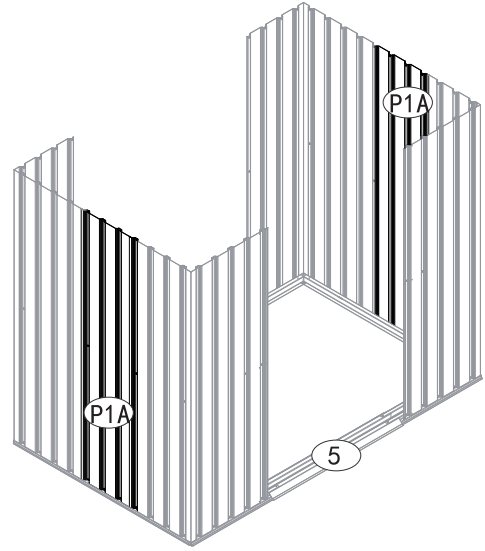
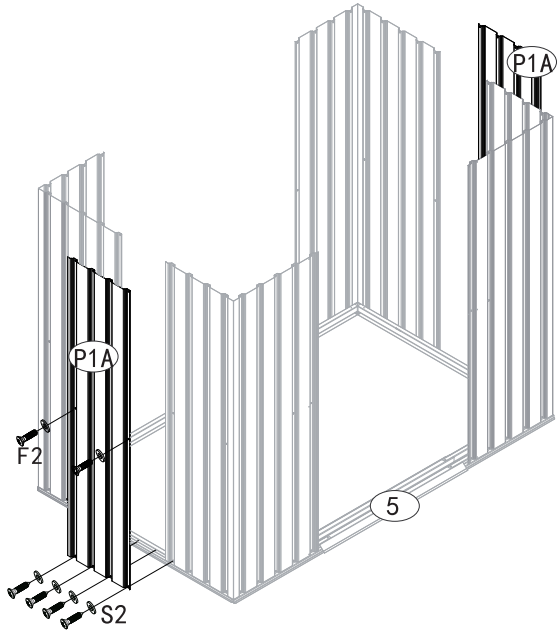

| PART | NO. | Qty. |
|---|-----|------|
|  | P1A | 2 |
|  | F2 | 4 |
|  | F1 | 8 |
|  | S2 | 8 |



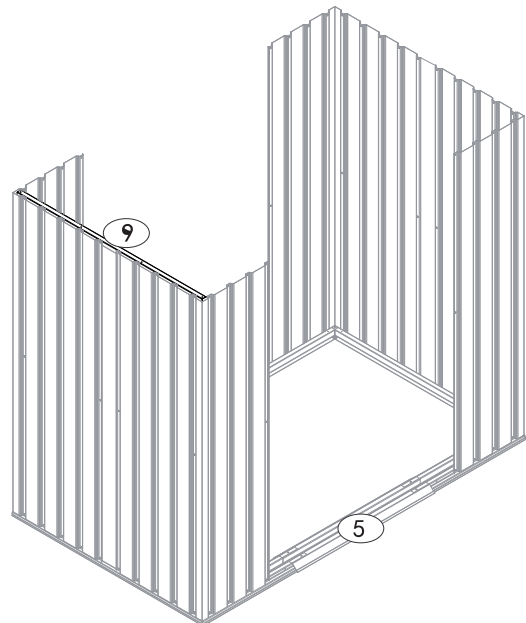
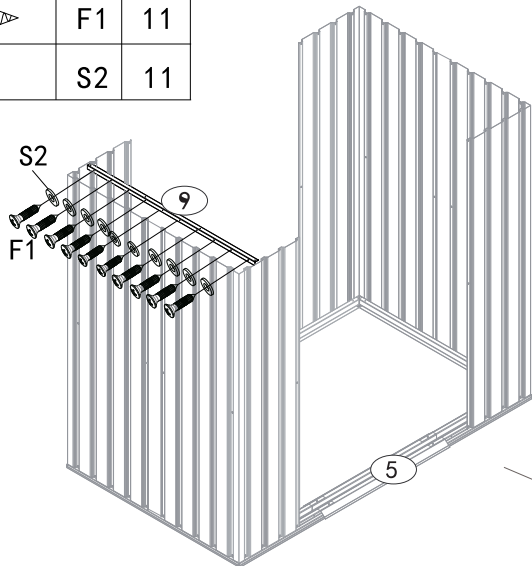

| PART | NO. | Qty. |
|---|-----|------|
|  | 9 | 1 |
|  | F1 | 11 |
|  | S2 | 11 |

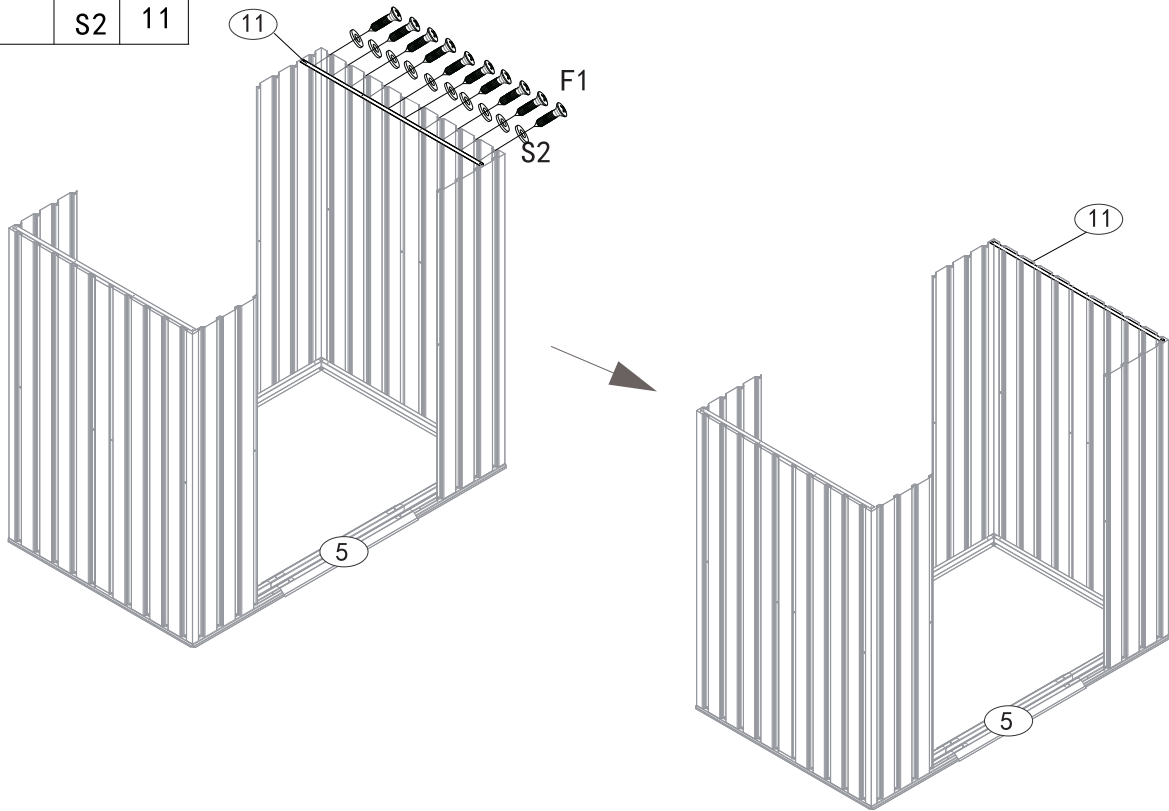

| PART | NO. | Qty. |
|---|-----|------|
|  | 11 | 1 |
|  | F1 | 11 |
|  | S2 | 11 |



| PART | NO. | Qty. |
|---|-----|------|
|  | 10R | 1 |
|  | F1 | 3 |
|  | S2 | 3 |

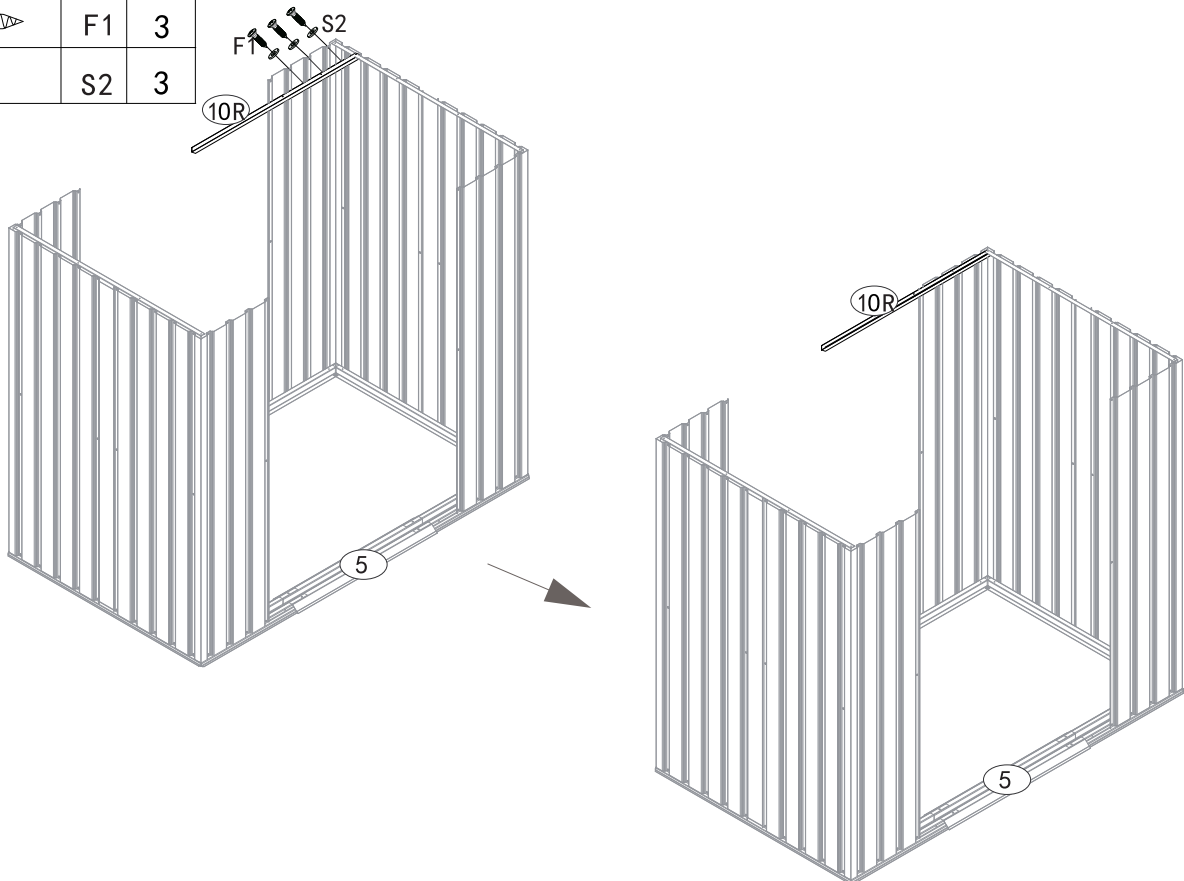



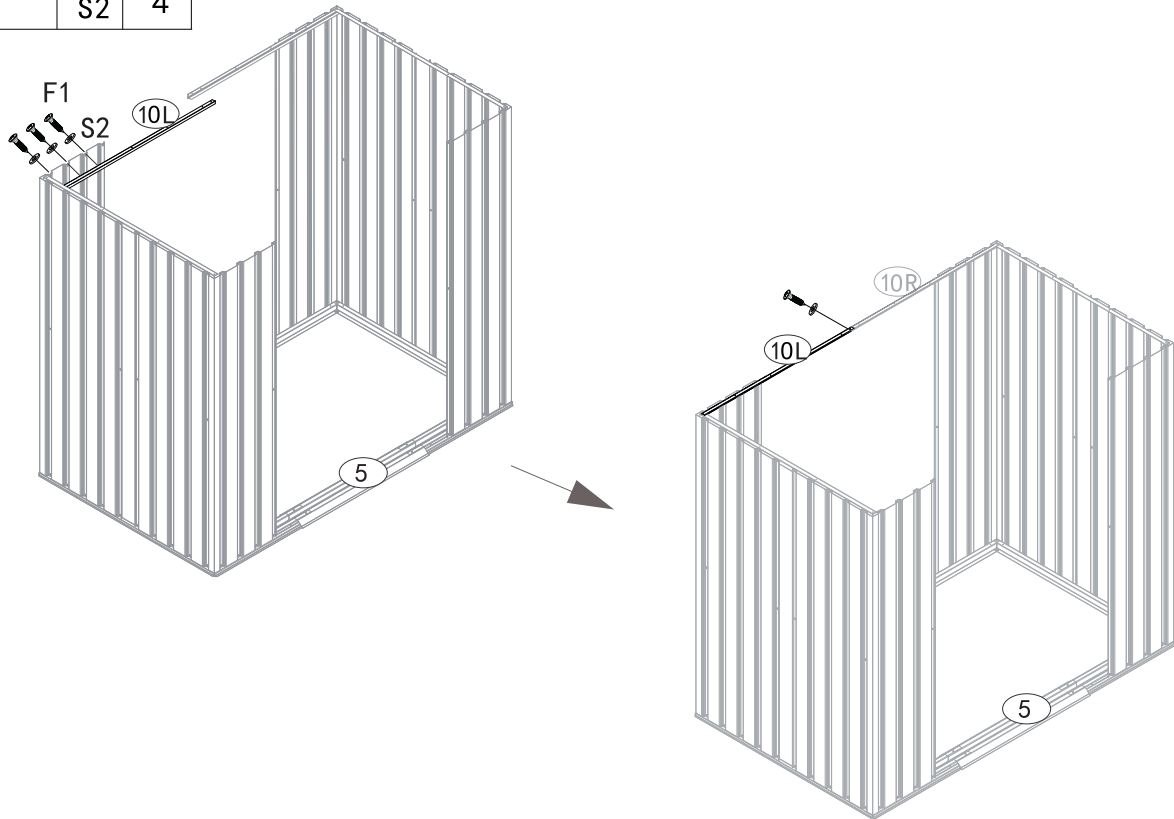

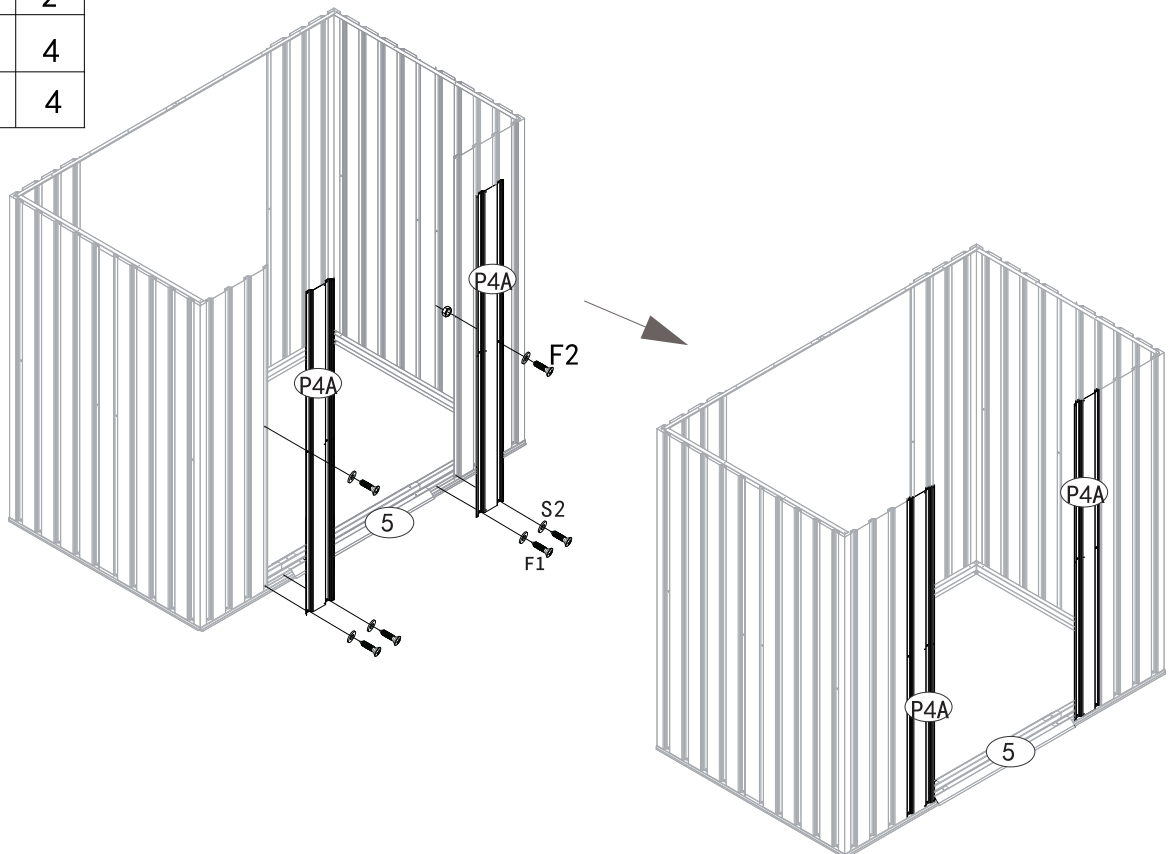

| PART | NO. | Qty. |
|------|-----|------|
| | 10L | 1 |
| | F1 | 4 |
| | S2 | 4 |

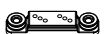

| PART | NO. | Qty. |
|------|-----|------|
| | P4A | 2 |
| | F2 | 2 |
| | F1 | 4 |
| | S2 | 4 |





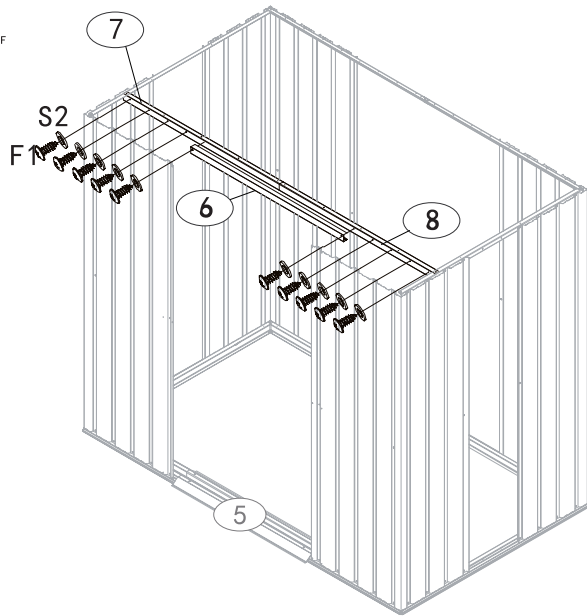
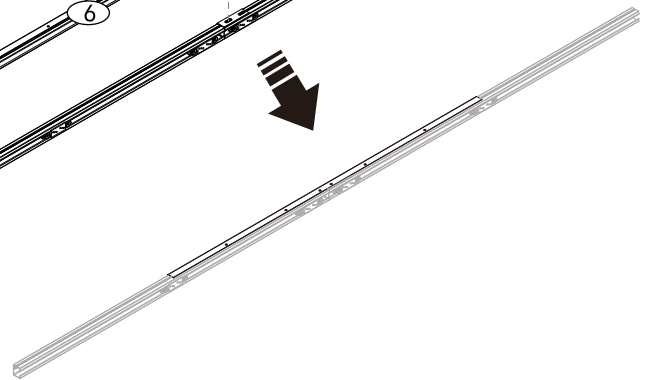
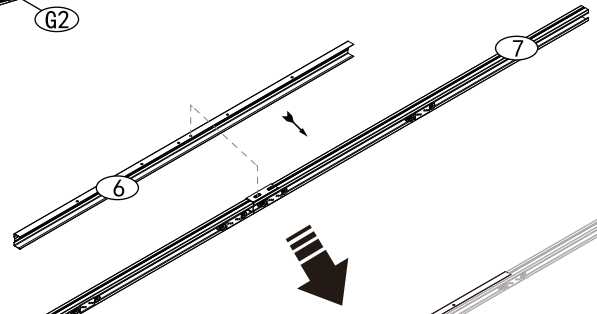
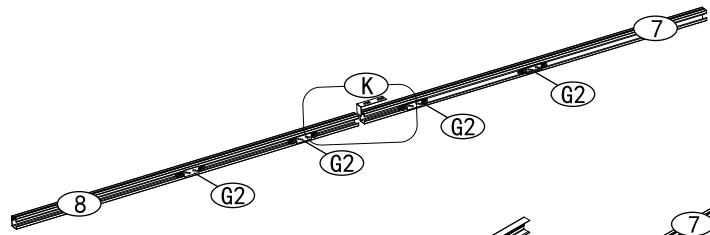
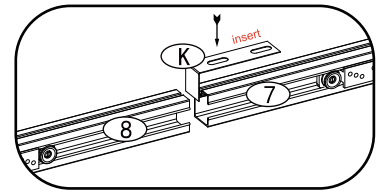
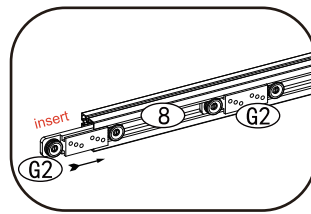

| PART | NO. | Qty. |
|---|-----|------|
|  | 6 | 1 |
|  | 7 | 1 |
|  | 8 | 1 |
|  | G2 | 4 |
|  | F1 | 10 |
|  | S2 | 10 |
|  | K | 1 |

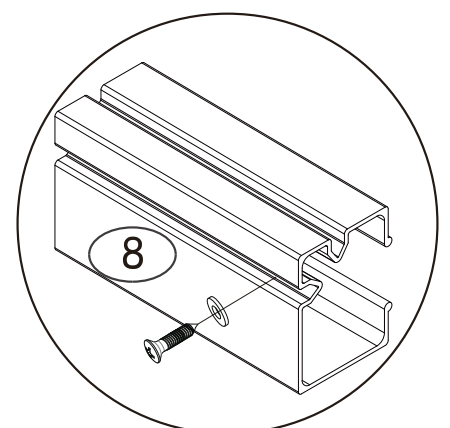
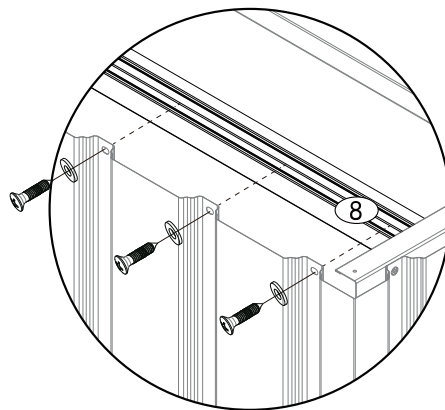
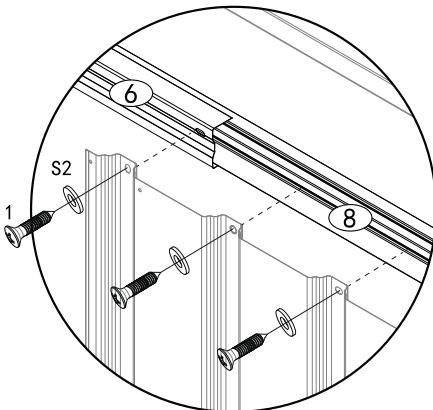





6.7.8 See the following page for installation details



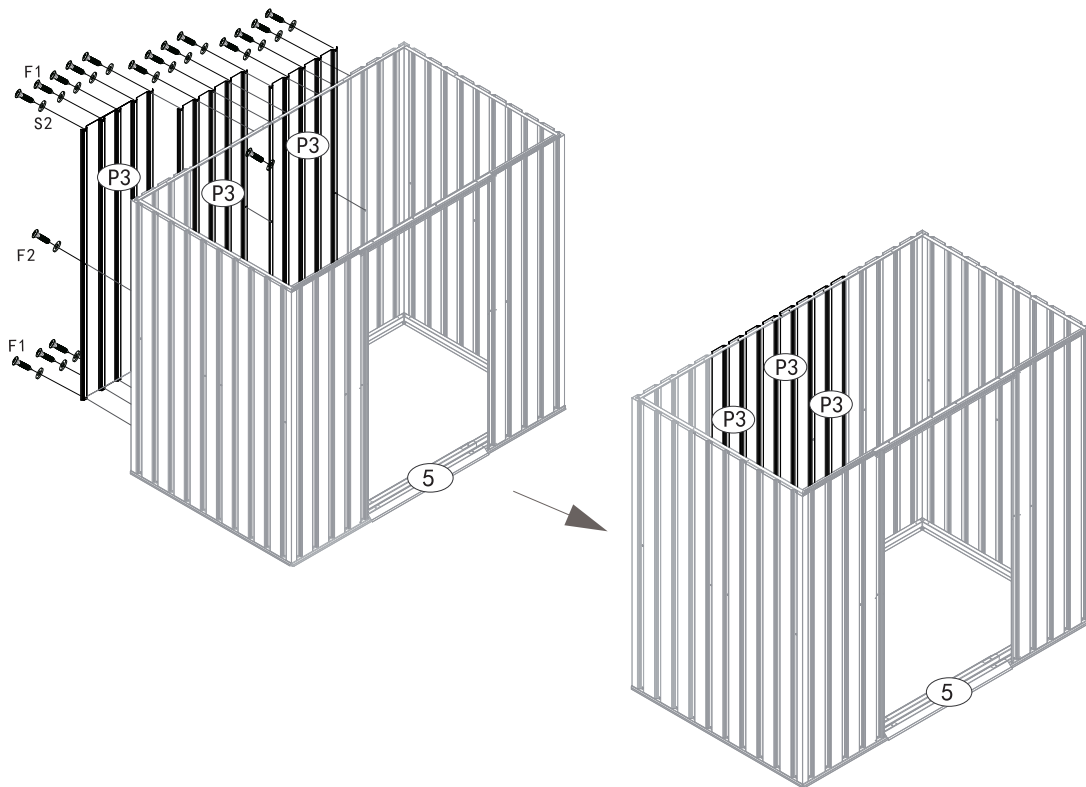





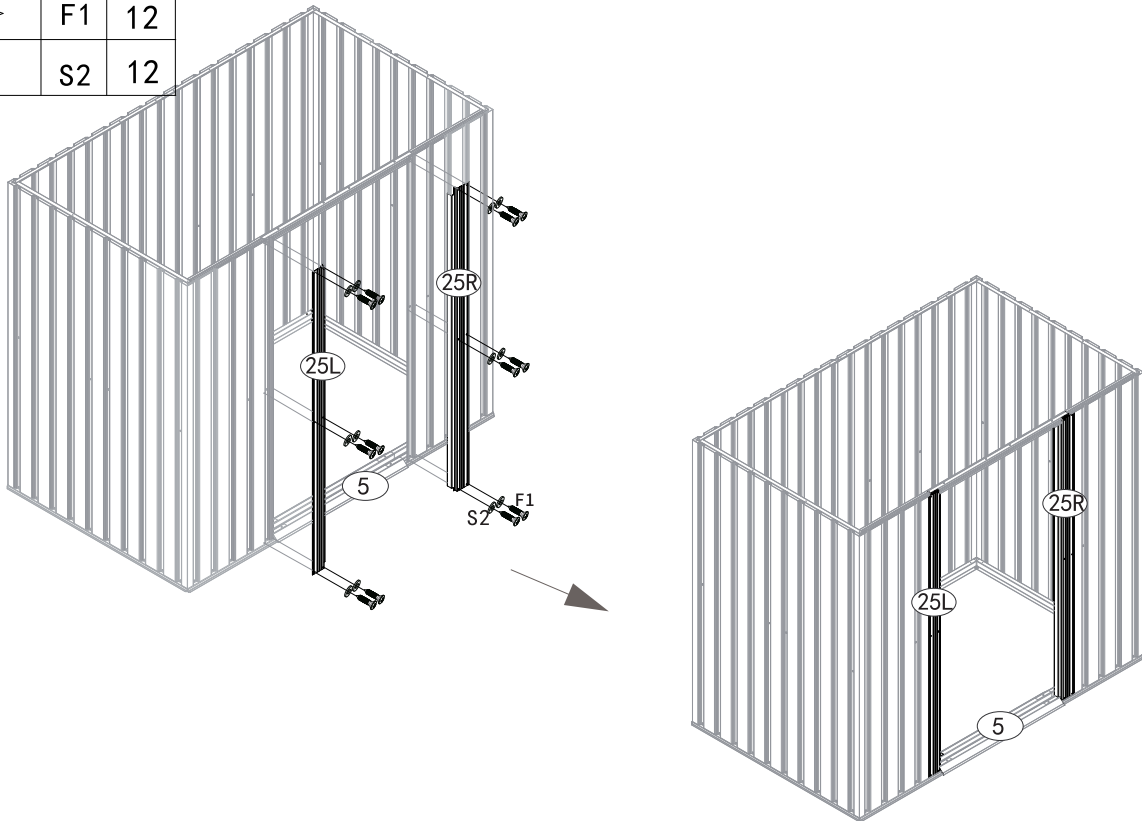

Screw mounting position

| PART | NO. | Qty. |
|---|-----|------|
|  | P3 | 3 |
|  | F2 | 4 |
|  | F1 | 26 |
|  | S2 | 29 |





| PART | NO. | Qty. |
|---|-----|------|
|  | 25L | 1 |
|  | 25R | 1 |
|  | F1 | 12 |
|  | S2 | 12 |



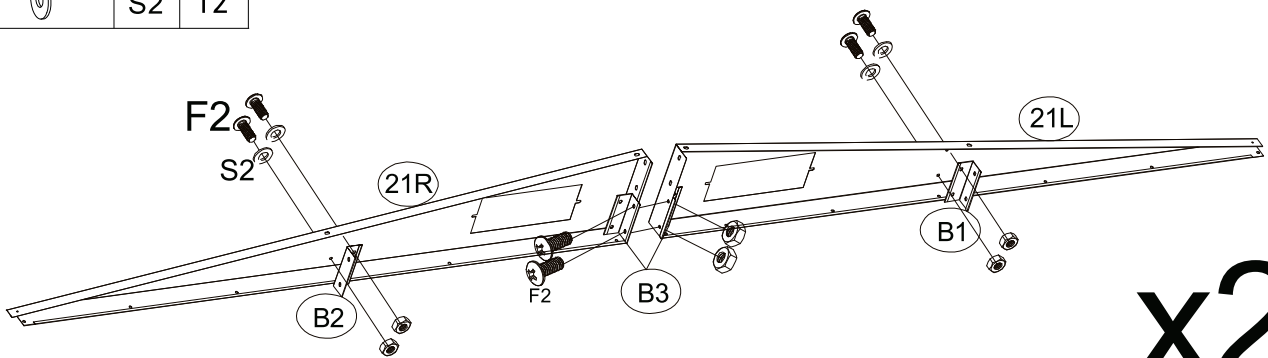

| PART | NO. | Qty. |
|---|-----|------|
|  | 21L | 2 |
|  | 21R | 2 |
|  | B1 | 2 |
|  | B2 | 2 |
|  | B3 | 4 |
|  | F2 | 12 |
|  | S2 | 12 |





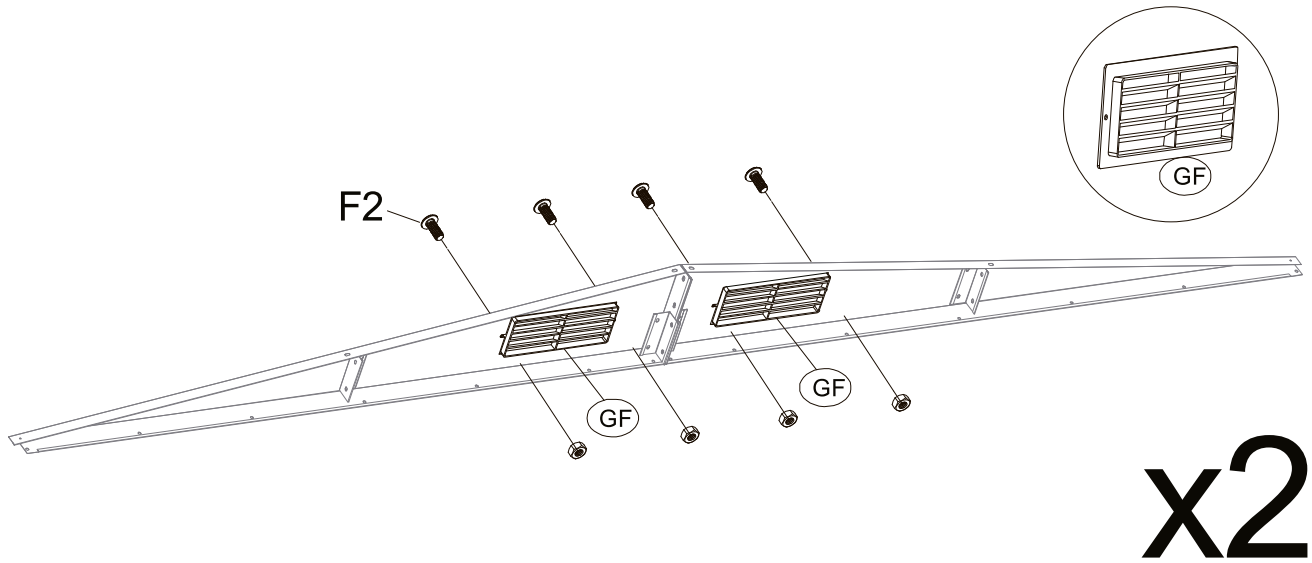

x2

| PART | NO. | Qty. |
|---|-----|------|
|  | GF | 4 |
|  | F2 | 8 |

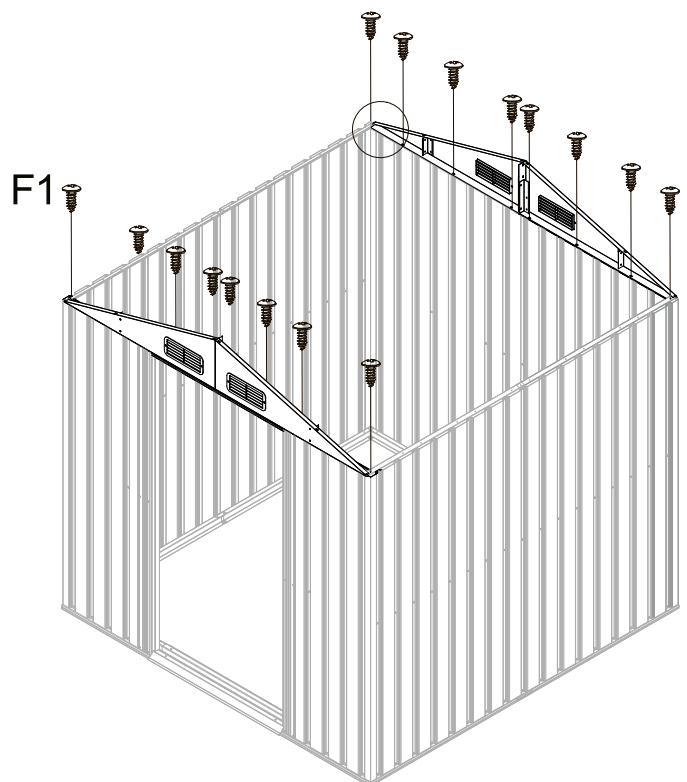
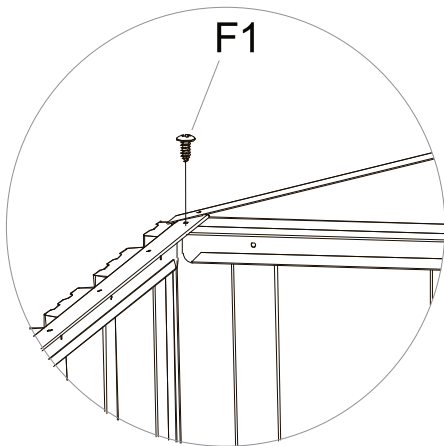

| PART | NO. | Qty. |
|---|-----|------|
|  | F1 | 16 |



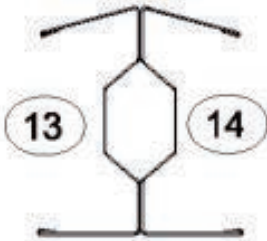
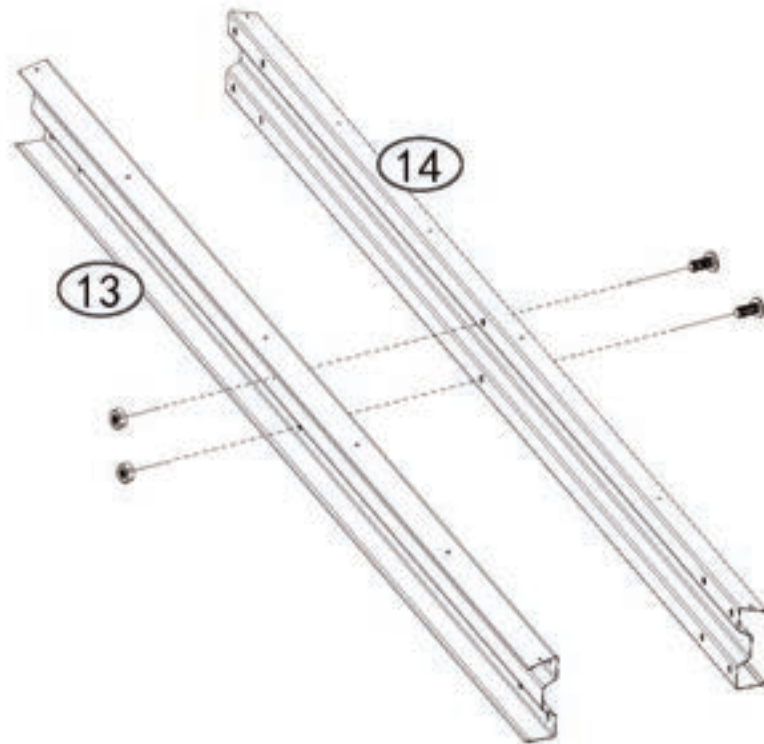

| PART | NO. | Qty. |
|---|-----|------|
|  | 13 | 1 |
|  | 14 | 1 |
|  | F2 | 2 |





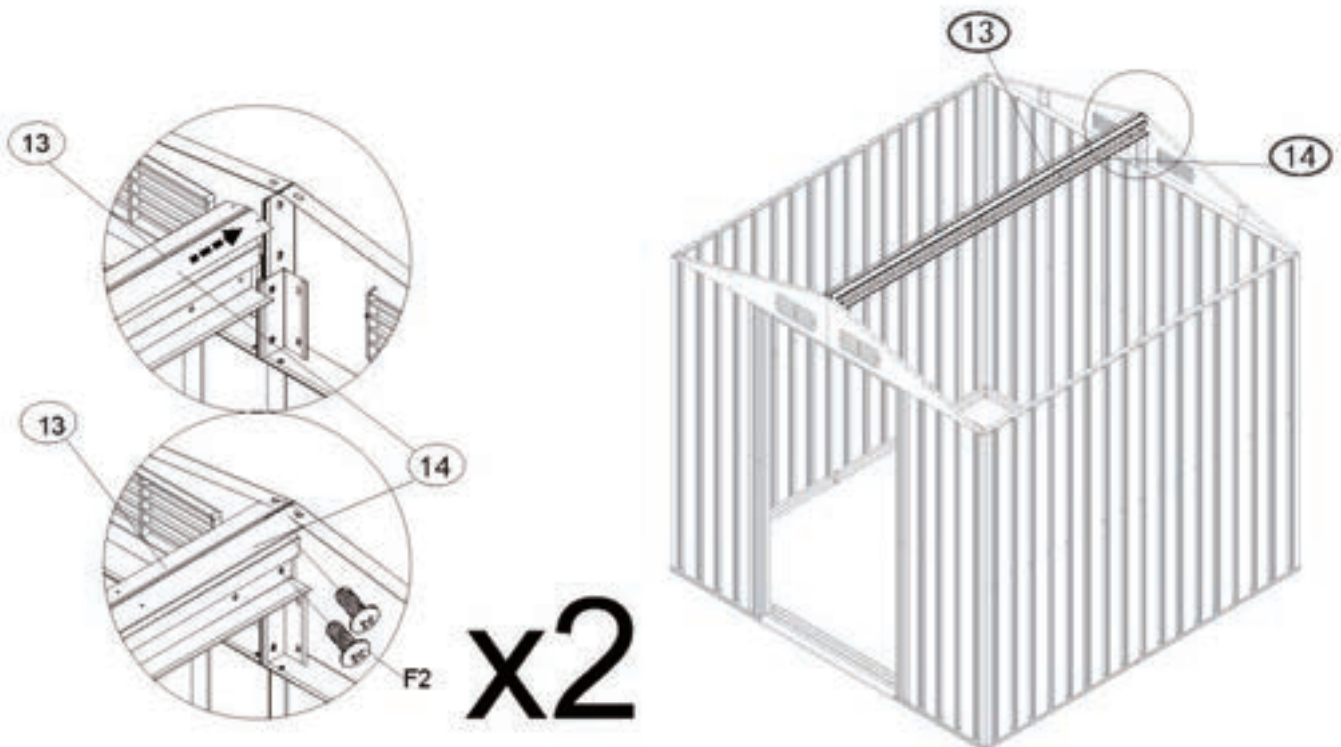

DE: Das gebogene Ende ist nach oben mit den Dachplatten verbunden. Das flache Ende ist nach unten gerichtet.
 EN: The curved end faces upwards and is connected to the roof panels. The flat end faces downwards.
 FR: L'extrémité courbée est connectée avec les plaques de toiture vers le haut. L'extrémité plate est orientée vers le bas.
 IT: L'estremità curvata è collegata verso l'alto con le lastre del tetto. L'estremità piatta è rivolta verso il basso.
 ES: El extremo arqueado se conecta hacia arriba con los paneles del techo. El extremo plano está orientado hacia abajo.
 NL: Het gebogen uiteinde is aan de bovenzijde verbonden met de dakpanelen. Het platte uiteinde is naar beneden gericht.
 PL: Zagiety koniec jest od góry polazony z płytami dachowymi. Płaski koniec jest skierowany w dół.

| PART | NO. | Qty. |
|---|-----|------|
|  | F2 | 4 |

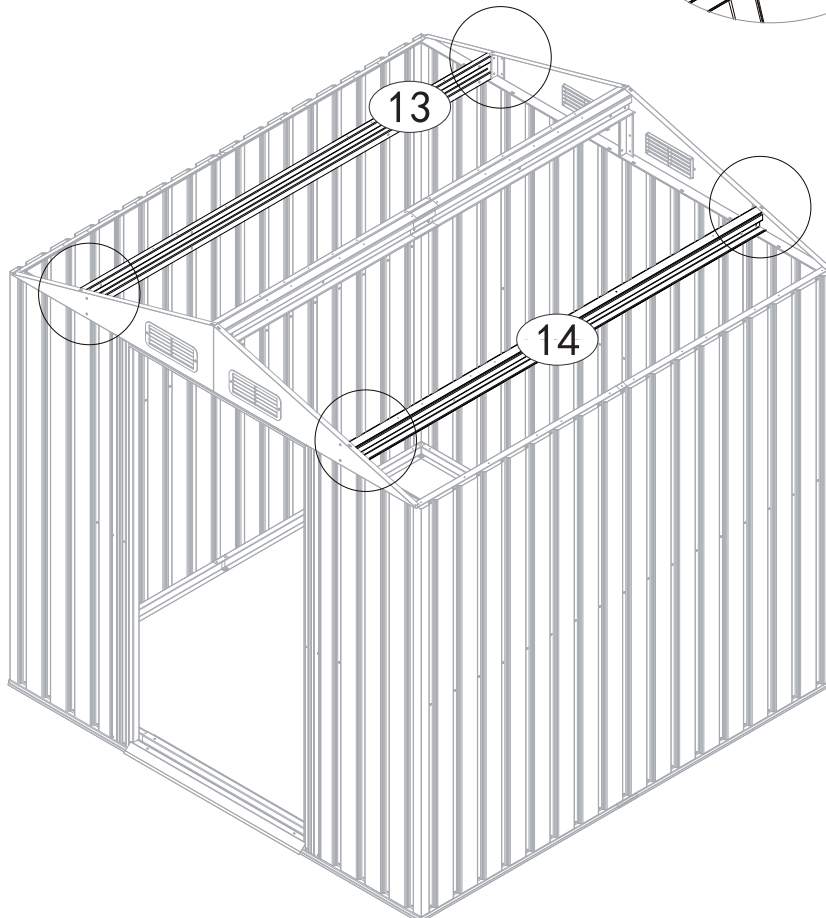
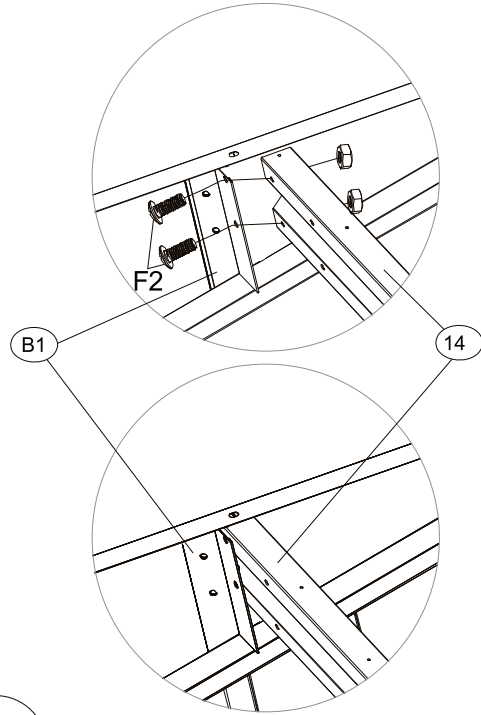
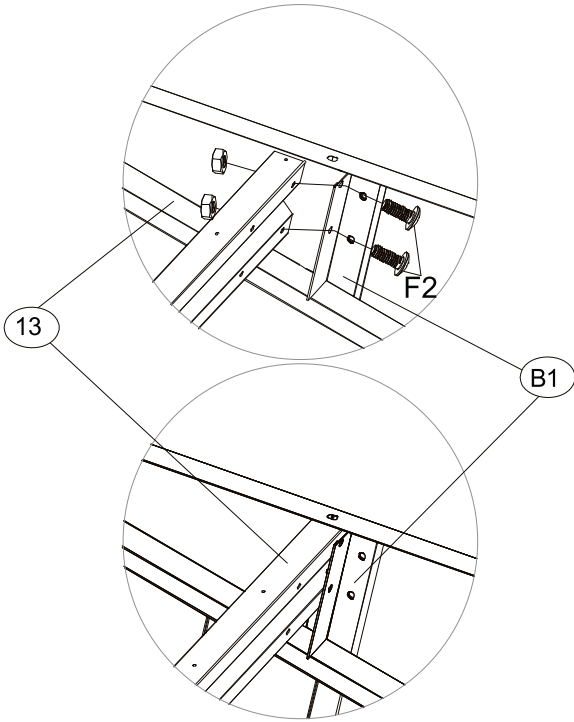



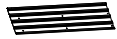

| PART | NO. | Qty. |
|---|-----|------|
|  | F2 | 8 |

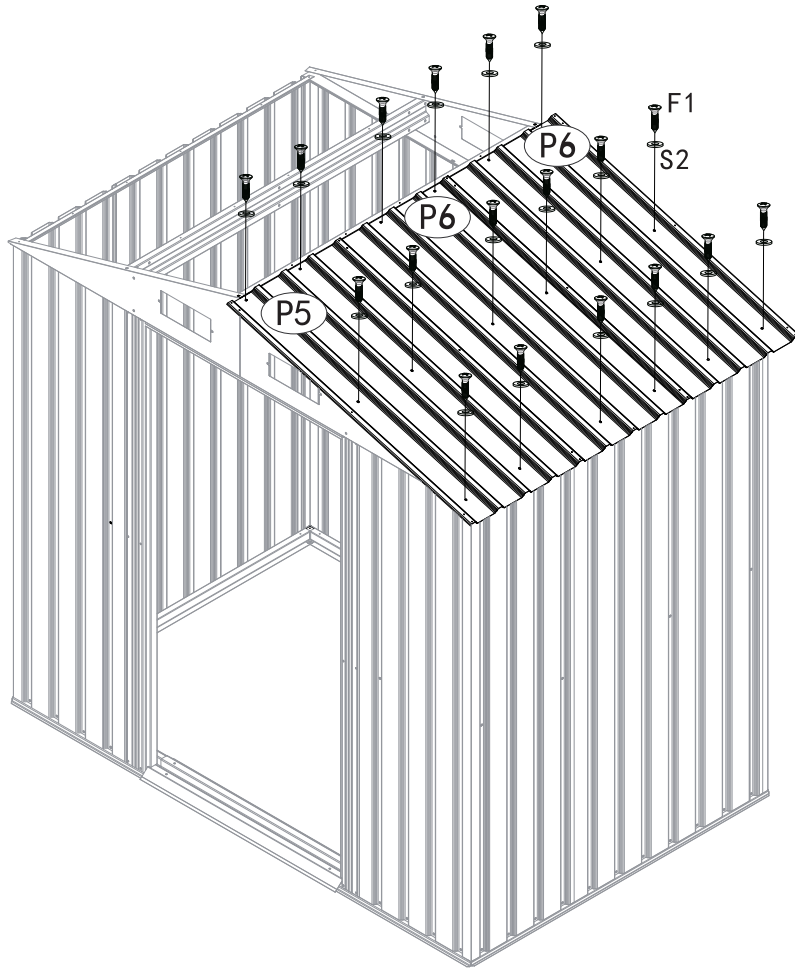

| PART | NO. | Qty. |
|---|-----|------|
|  | P5 | 1 |
|  | P6 | 2 |
|  | F1 | 18 |
|  | S2 | 18 |



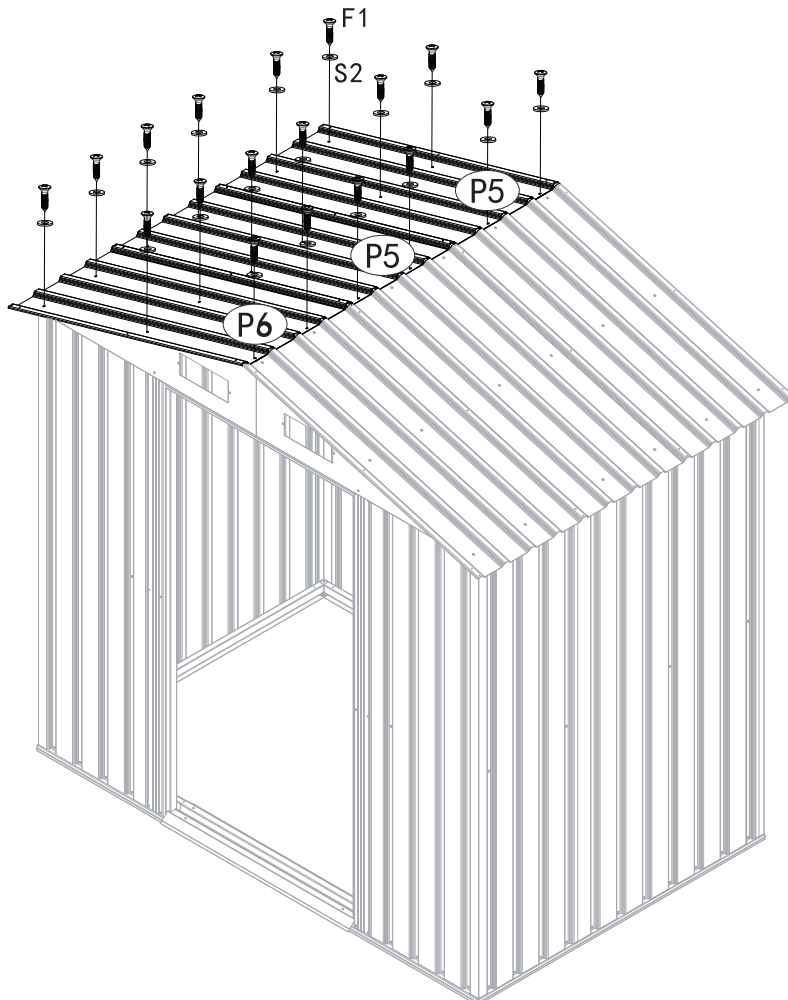

| PART | NO. | Qty. |
|---|-----|------|
|  | P5 | 2 |
|  | P6 | 1 |
|  | F1 | 18 |
|  | S2 | 18 |

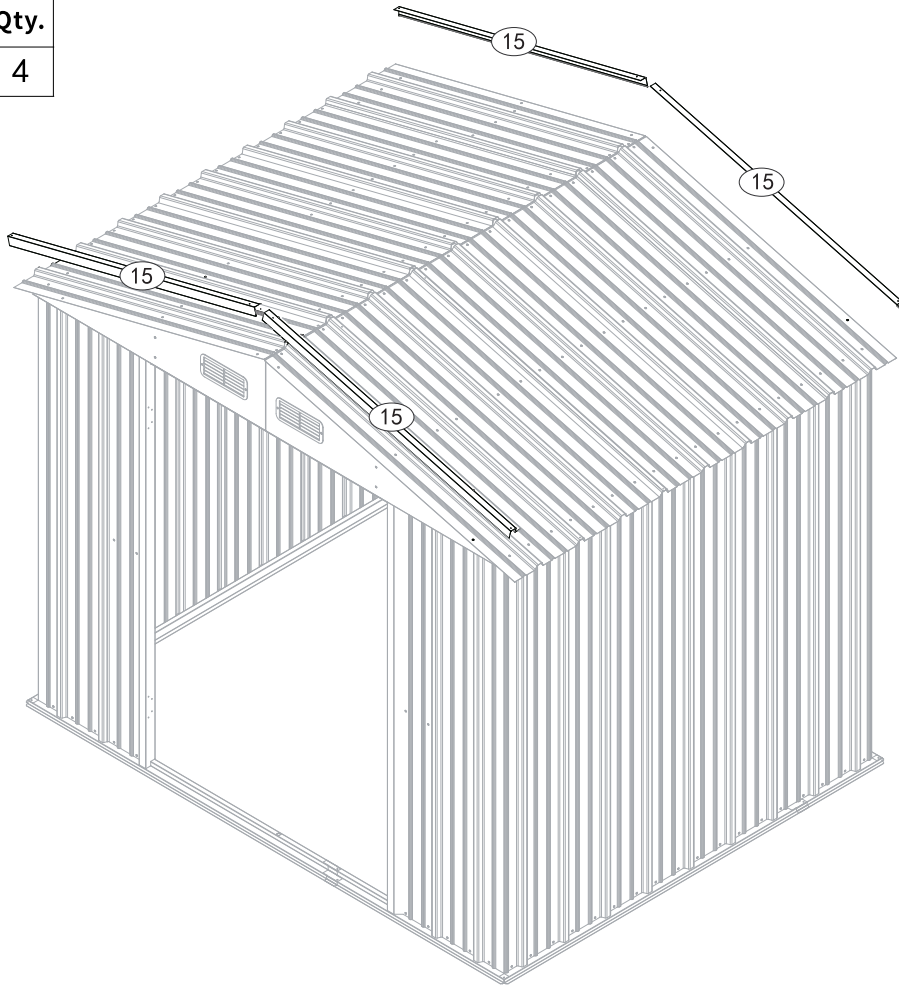

| PART | NO. | Qty. |
|---|-----|------|
|  | 15 | 4 |





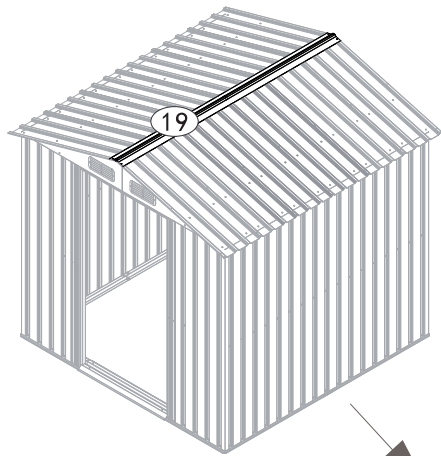

| PART | NO. | Qty. |
|---|-----|------|
|  | 19 | 1 |
|  | GE | 2 |
|  | F1 | 6 |

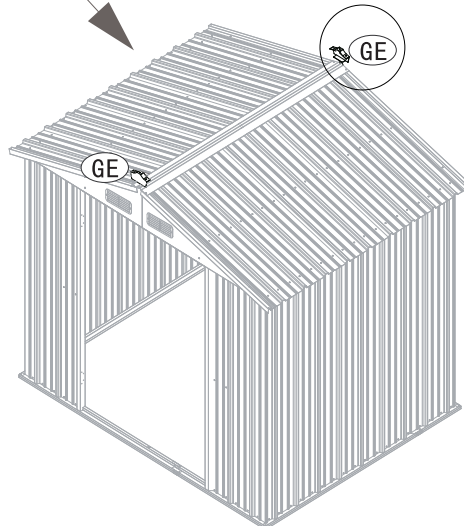
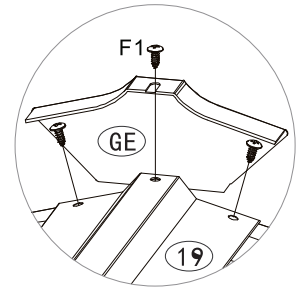





x2

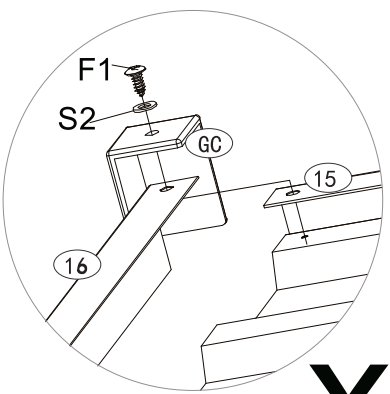
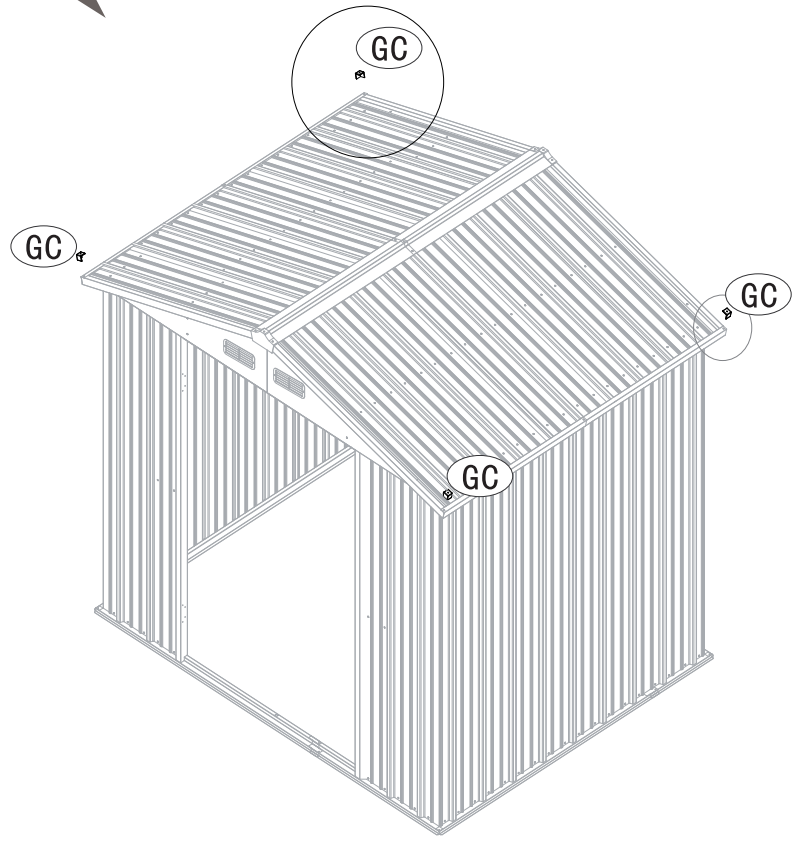
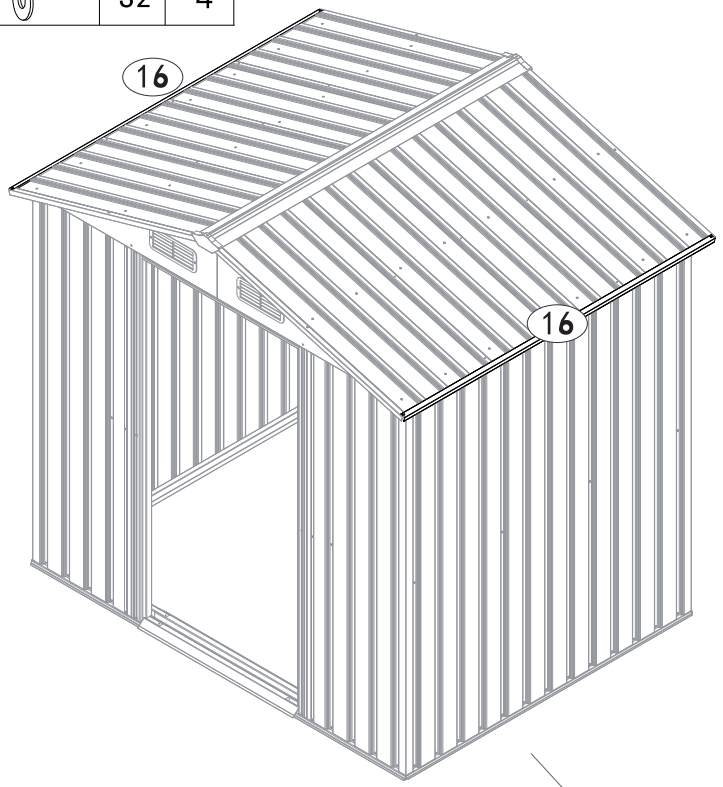

| PART | NO. | Qty. |
|---|-----|------|
|  | 16 | 2 |
|  | GC | 4 |
|  | F1 | 4 |
|  | S2 | 4 |





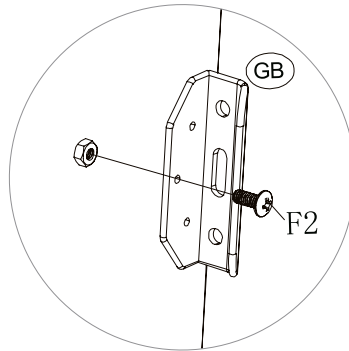
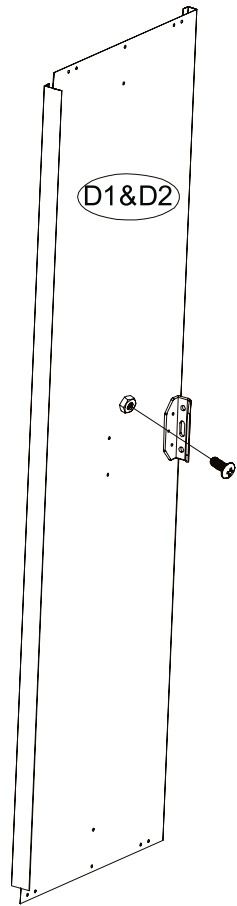

x4

| PART | NO. | Qty. |
|---|-----|------|
|  | D1 | 1 |
|  | D2 | 1 |
|  | GB | 2 |
|  | F2 | 2 |



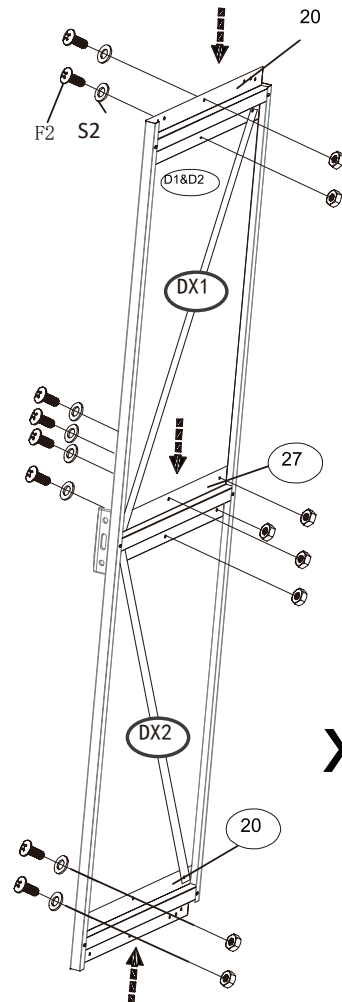

x2

| PART | NO. | Qty. |
|---|-----|------|
|  | 20 | 4 |
|  | 27 | 2 |
|  | DX1 | 2 |
|  | DX2 | 2 |
|  | F2 | 36 |



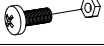

x2

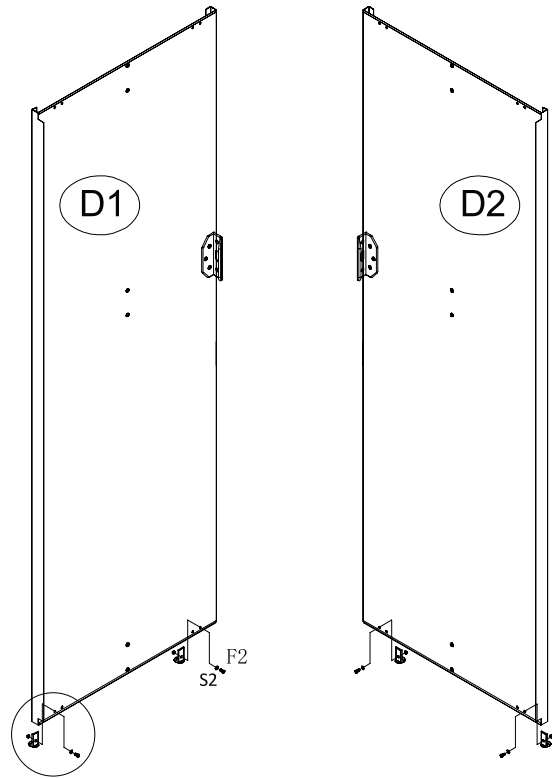
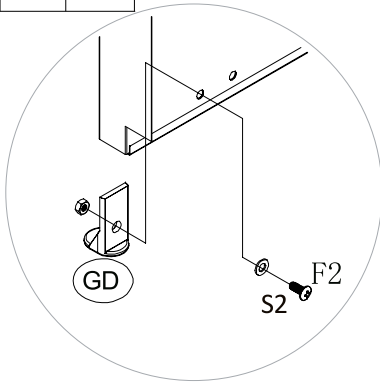
| PART | NO. | Qty. |
|---|-----|------|
|  | GD | 4 |
|  | F2 | 4 |
|  | S2 | 4 |

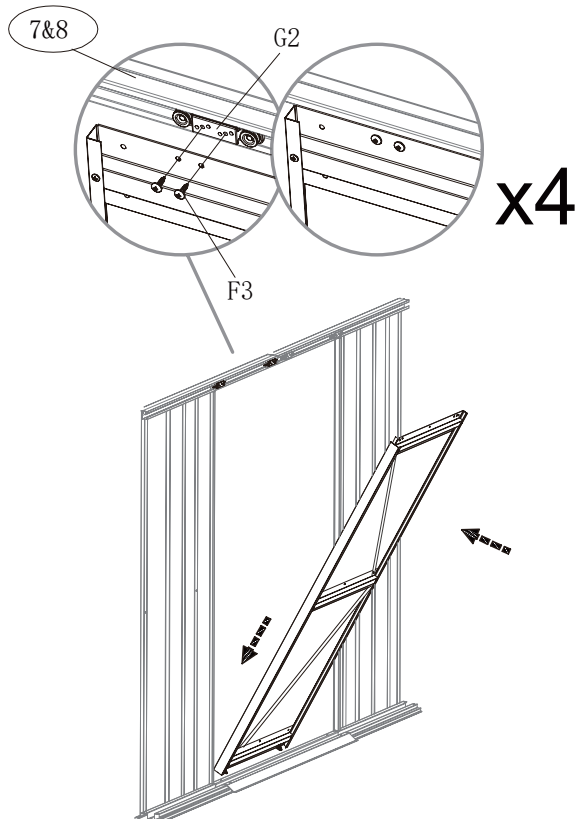

| PART | NO. | Qty. |
|---|-----|------|
|  | F3 | 8 |



| PART | NO. | Qty. |
|---|-----|------|
|  | S1 | 142 |

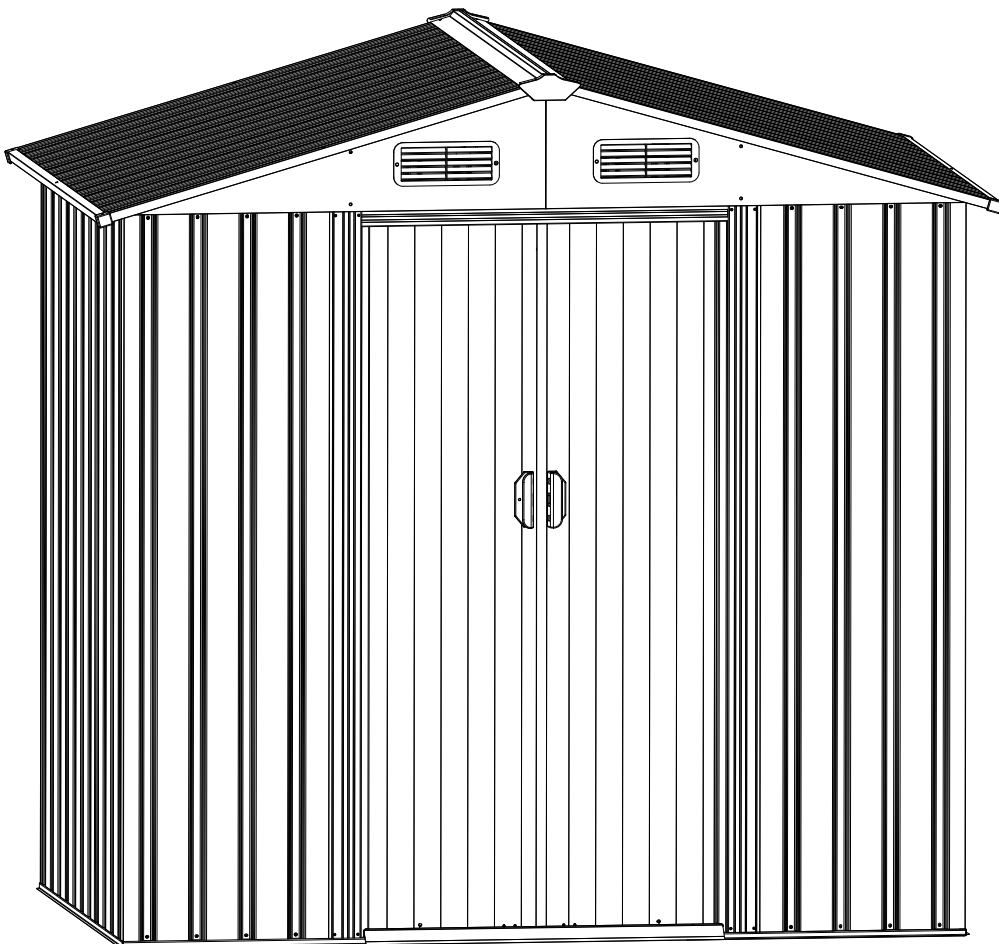
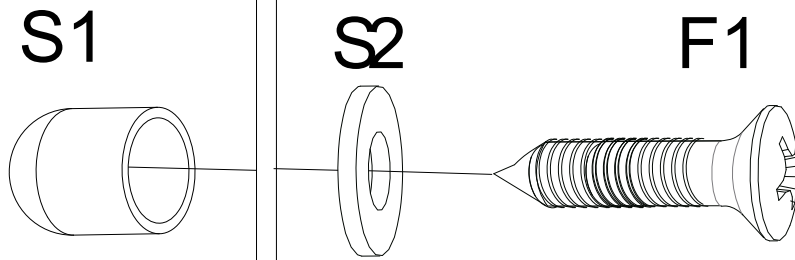

US

Imported by Aosom LLC
 27150 SW Kinsman Rd Wilsonville, OR 97070 USA
 MADE IN CHINA

CA

Imported by Aosom Canada Inc.
 7270 Woodbine Avenue, Unit 307, Markham, Ontario Canada
 L3R 4B9
 MADE IN CHINA

Importé par Aosom Canada Inc.
 7270 Woodbine Avenue, unité 307, Markham, Ontario Canada
 L3R 4B9
 Fabriqué en Chine

UK

IMPORTER ADDRESS:
 MH STAR UK LTD
 Unit 27, Perivale Park,
 Horsenden lane South
 Perivale, UB6 7RH
 MADE IN CHINA

FR

ADRESSE D'IMPORTATION:
 MH FRANCE
 2 Rue Maurice Hartmann
 92130 Issy Les Moulineaux
 France
 FABRIQUÉ EN CHINE



Adresses sur quefairedemesdechets.fr

ES

IMPORTADOR:
 SPANISH AOSOM, S.L.
 C/ROC GROS, Nº15.08550, ELS HOSTALETS DE BALENYÀ, SPAIN.
 B66295775
 WWW.AOSOM.ES
 ATENCIONCLIENTE@AOSOM.ES
 TEL: 931294512
 HECHO EN CHINA

PT

SPANISH AOSOM, S.L
 C.ROC GROS N.15, 08550. ELS HOSTALETS DE BALENYÀ
 TEL: 931294512 (SEG-SEX DAS 7:30H ÀS 16:30H)
 INFO@AOSOM.PT
 WWW.AOSOM.PT

DE

ADRESSE DES IMPORTEURE:
 MH Handel GmbH
 Wendenstraße 309
 D-20537 Hamburg
 Germany
 IN CHINA HERGESTELLT

IT

IMPORTATO DA:
 AOSOM Italy srl
 Centro Direzionale Milanofiori
 Strada 1 Palazzo F1
 20057 Assago (MI)
 P.I.: 08567220960
 FATTO IN CINA