

## SPECIFICATIONS

## 5 BUTTON WIRELESS WALL SWITCH

Input Voltage: DC 3V

Bluetooth Transmit: 100ft Max

Radio Frequency: 2.4GHz ± 75MHz

Bluetooth Version: 4.2

Housing Material: UL 94-V0

Indoor Use Only

Operating Temperature: -18°C to 50°C,  
-0.4°F to 122°F

Storage Temperature: 0°C to 30°C,  
32°F to 86°F

IP Rating: IP20

Color: White

Warranty: Limited Lifetime

Comply to UL1376, RoHS

FCC ID: 2A26YLTKTVT2021

DID: D057145

DLC: NLTRC5KL0TN



### FEATURES

The SMRT-5B-WIRELESS-WH-BT 5 Button Wall Switch is a true Workhorse! It houses 2, CR2032 Batteries with a life of approx 5 years, depending on usage. It can be mounted in a wall, (no junction box required, check your local codes), or sit on a desk top and be used as a remote control. The wall switch is On/Off, Raise or Lower the light level, set up to 3 scenes, and has an Auto mode, that when activated runs off of the Ceiling Sensors. This powerful wall switch can be set up and configured in the SMRT Bluetooth app.

### DIMENSIONS / WIRING / DETAILS

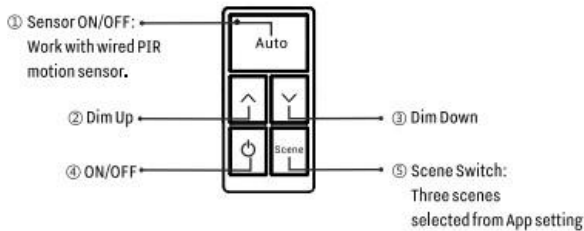
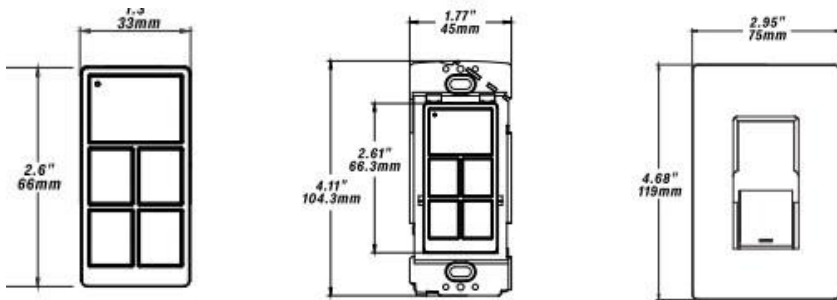

#### Wall Switch Configuration:

- 1) Install 2 pcs CR2032 by opening back cover.
- 2) Press button 1 and button 2 together and hold for 2 seconds to enter pairing mode, or to achieve reset function. Now the switch can be scanned in the next 30 seconds.
- 3) In the SMRT App "Switch" page, click to add the switch.
- 4) Select the light/light group to be controlled by this switch.
- 5) Select 3 scenes to be controlled by this switch.
- 6) When selecting "Auto" mode on the wall switch or in the app, the wall switch will now work entirely with the ceiling mounted motion sensor. This can again be bypassed by making any selection on the wall switch.

