

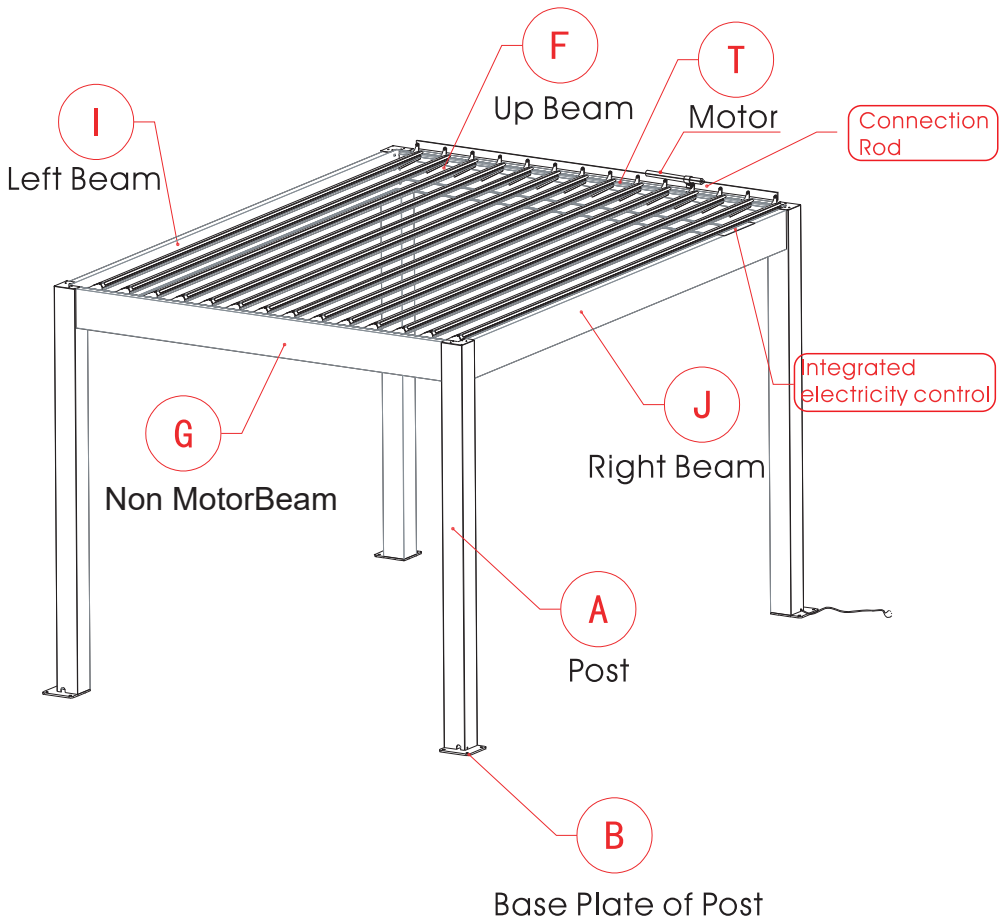











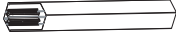



# BON PERGOLA



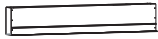





DESIGNED IN CALIFORNIA

## Weatherproof Pergola Assembly Instruction



# ● LIST OF ALUMINIUM PROFILE AND COMPONENTS

NO.	Name	Item	QTY
A	Post		X4
B	Base Plate of Post		X4
C	M8*30 Hexagon Countersunk Head Screws		X4
D	ST4.2*30 Phillips countersunk head self-tapping screw		X24
E	M6*16 socket head pan head screw		X24
F	Up Beam		X1
G	Down Beam		X1
H	ST4.2*16 Phillips pan head self-tapping screw		X50
I	Left Beam		X1
J	Right Beam		X1
K	Post Decoration Cover		X4
L	Water outlet unit		X4
M	Water outlet aluminium sheet		X4
N	Gutter		X4

NO.	Name	Item	QTY
O	Gutter Clamp		X4
P	Sub-frame Cover		X1
Q	Blade plastic base cover		quantities varies by sizes
R	Connection Rod Screw		
T	Motor		X1
aa	Blade without LED		quantities varies by sizes
bb	Blade with LED		
dd	LED Light Wire		X1
ee	Europe Plug		US plug

# • Install Base Plate to Post

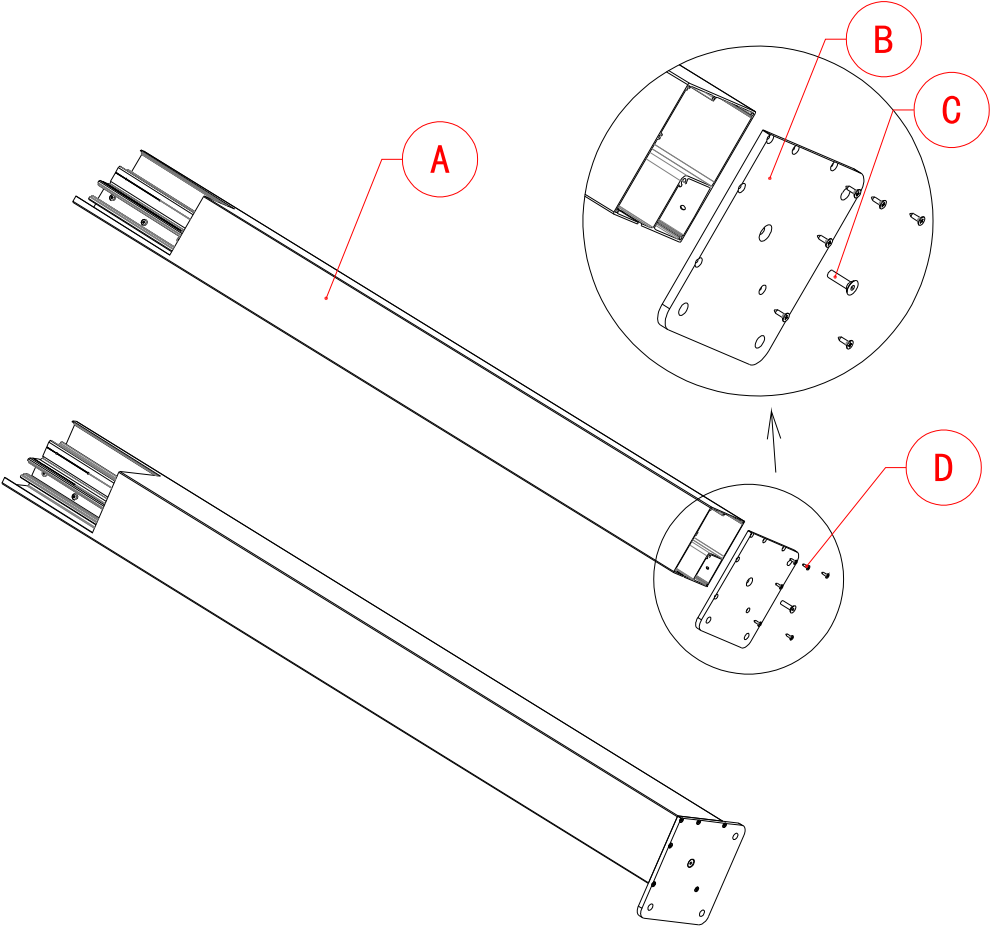
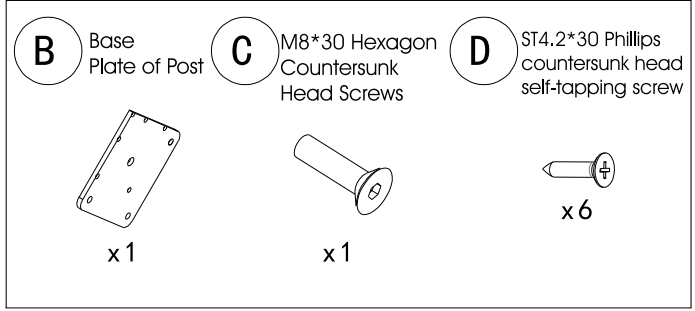
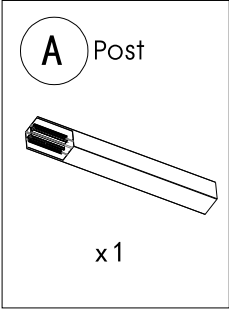

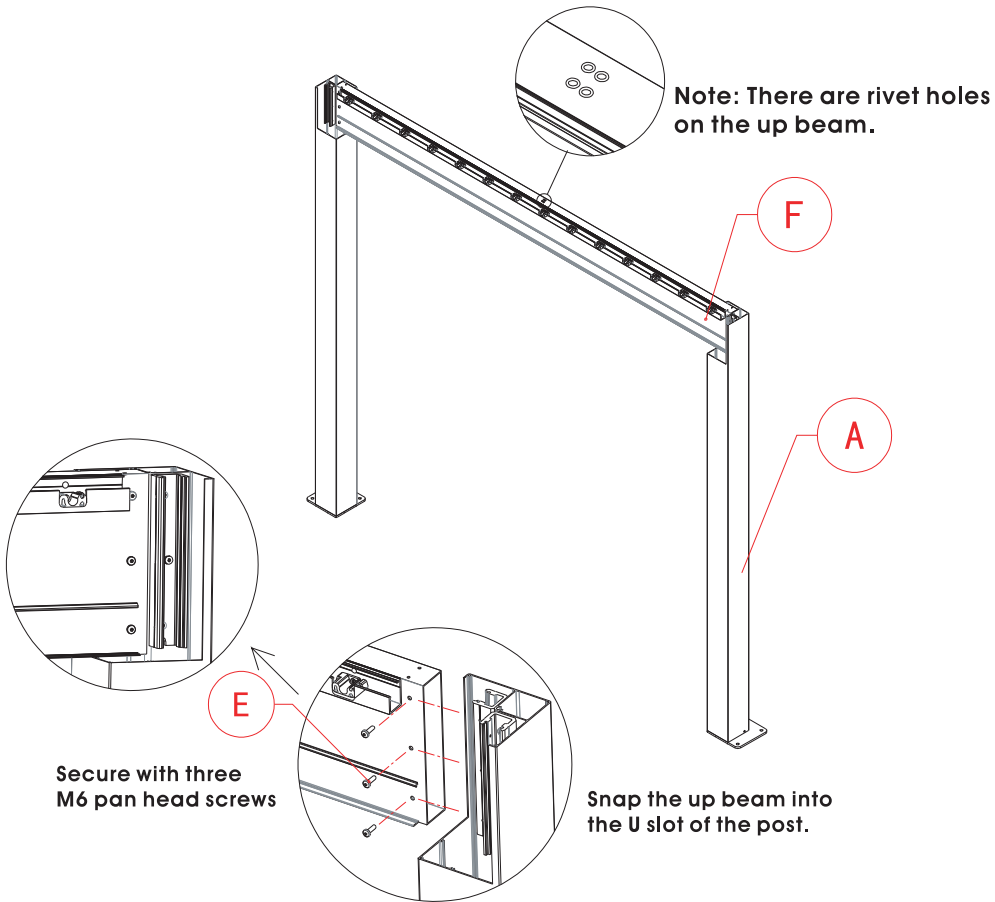
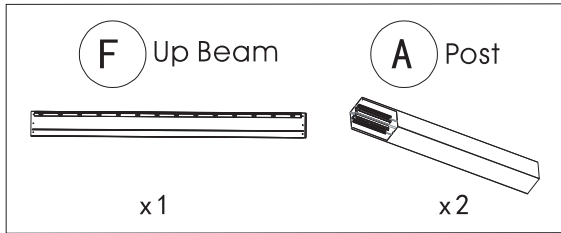
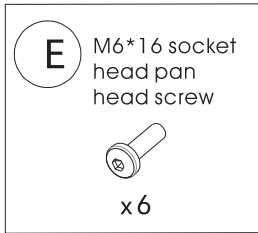

# ● Assemble the beam and post

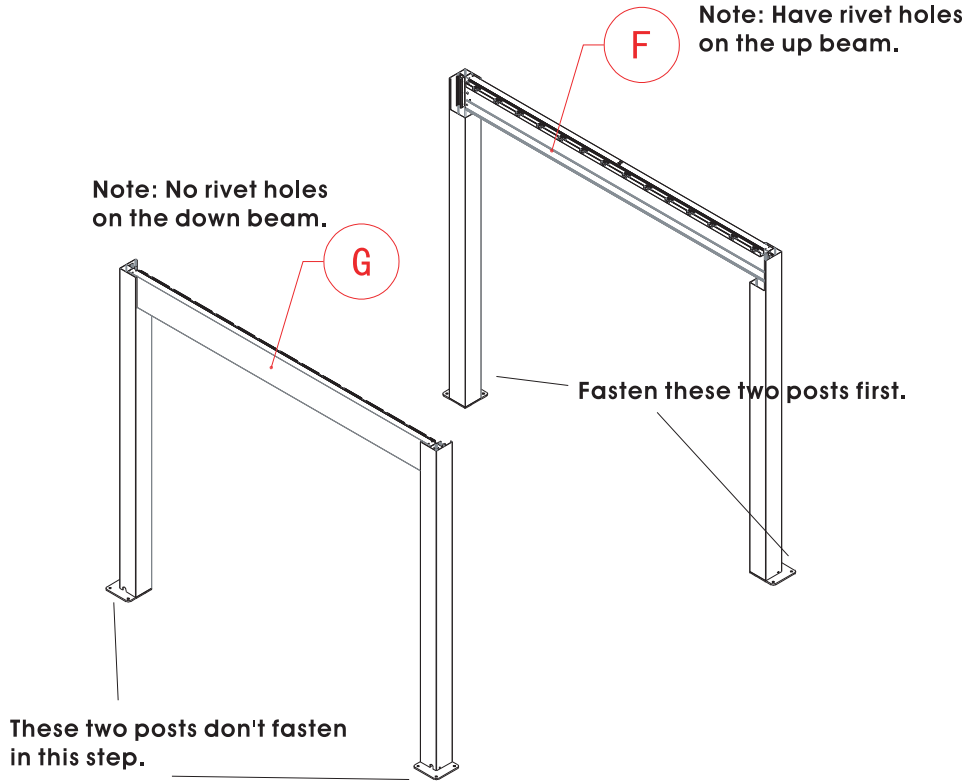

If you have the wall mount version, please locate the wall side beam, assemble the angle bracket, determine your correct height and use the correct bolt to bolt (wood/concrete/other) onto your desire location first.  
(You can also use the freestanding post to set a reference height)

# ● Fasten the post



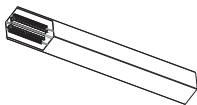



<b>F</b> Up Beam	<b>G</b> Down Beam	<b>A</b> Post
		
x1	x1	x4

If you have the wall mount version, please locate the wall side beam, assemble the angle bracket, determine your correct height and use the correct bolt to bolt (wood/concrete/other) onto your desire location first.

(You can also use the freestanding post to set a reference height)

# • Assemble the frame

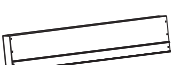
<p><b>E</b> M6*16 socket head pan head screw</p>  <p>x6</p>	<p><b>H</b> ST4.2*16 Phillips pan head self-tapping screw</p>  <p>x28</p> <p><b>K</b> Post Decoration Cover</p>  <p>x4</p>	<p><b>I</b> Left Beam</p>  <p>x1</p> <p><b>J</b> Right Beam</p>  <p>x1</p>
--	--	---

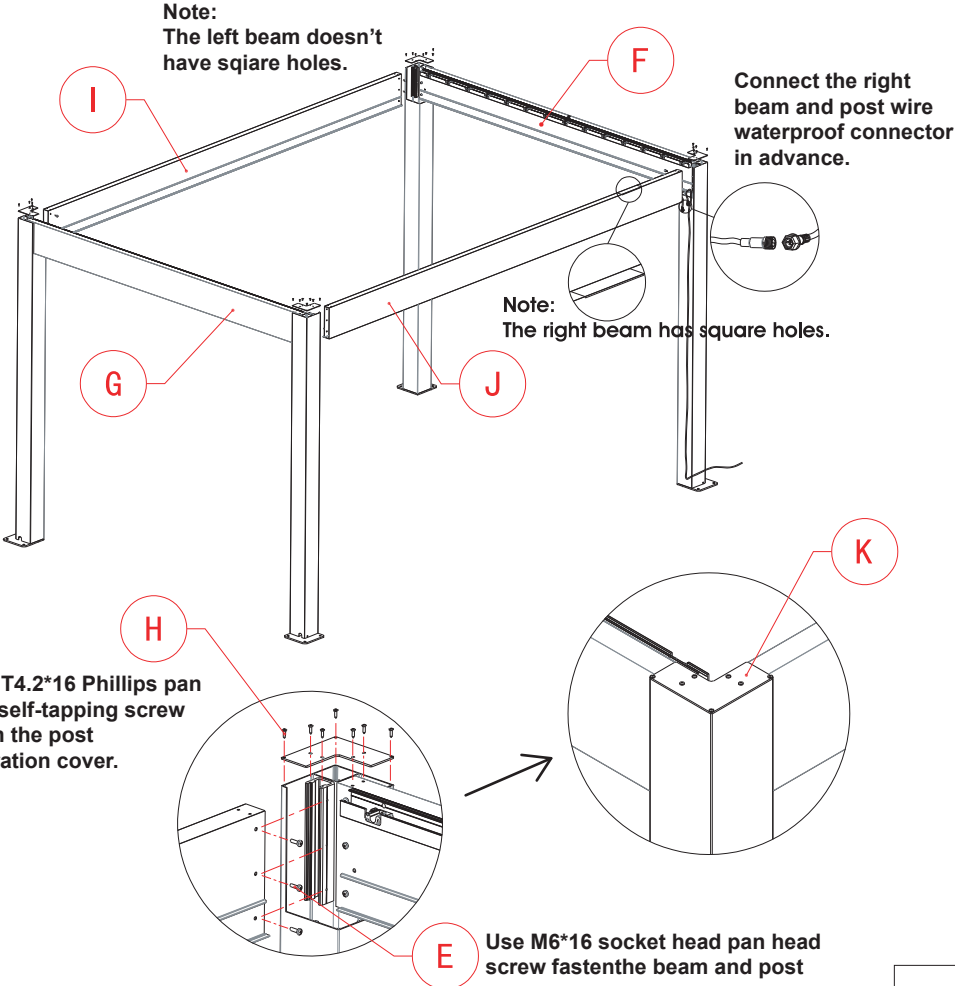

## ● Adjust and fasten the frame

Measure and keep the same distance of diagonal and line between two posts.

Dimension	L	L1	L2
15'x15'	237.86"	180"	180"
15'x19'	273.91"	180"	228"

This size depend on your custom pergola

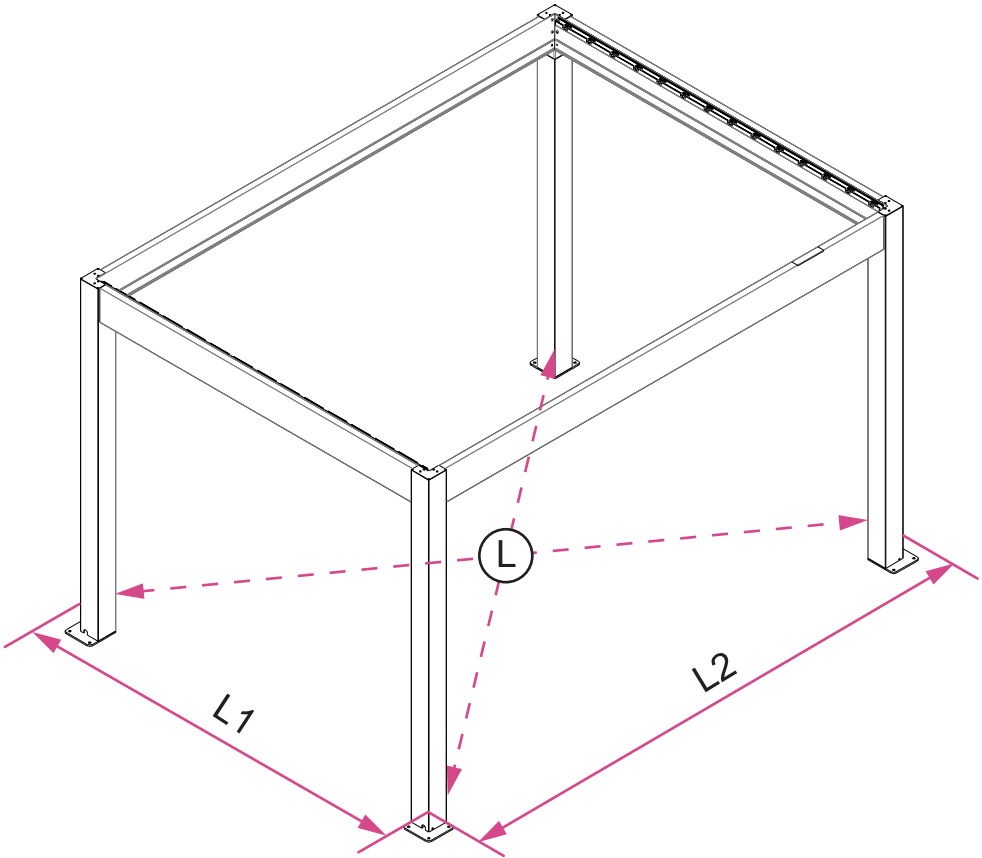

# • Install Gutter Corner

Seal the frame and beam with sealant, then fasten the water outlet unit and aluminium sheet.

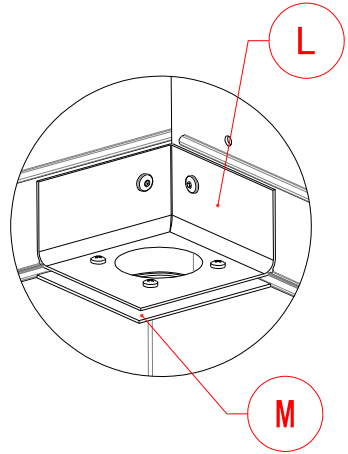
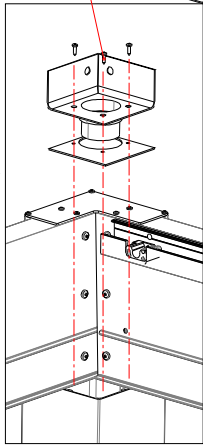
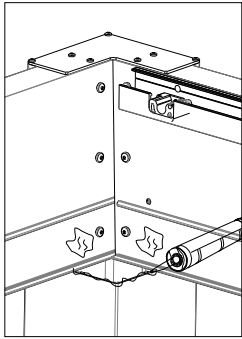
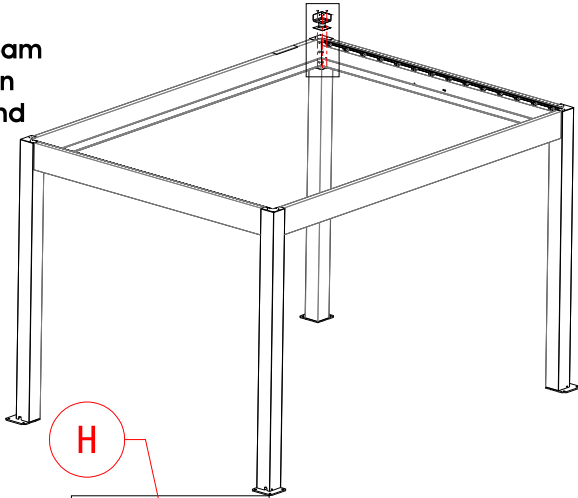

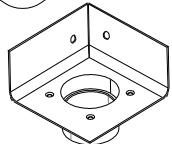
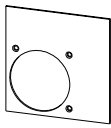
 <b>H</b> ST4.2*16 Phillips pan head self-tapping screw x12	 <b>L</b> Water outlet unit x4	 <b>M</b> Water outlet aluminium sheet x4
--	---	--



# • Install Gutter

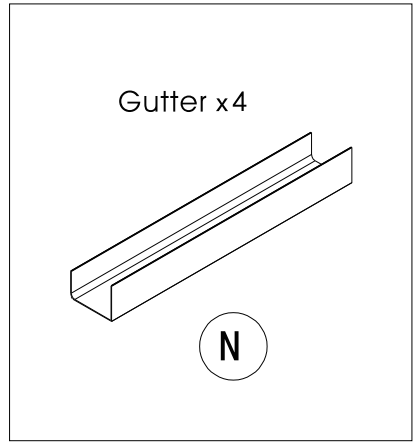
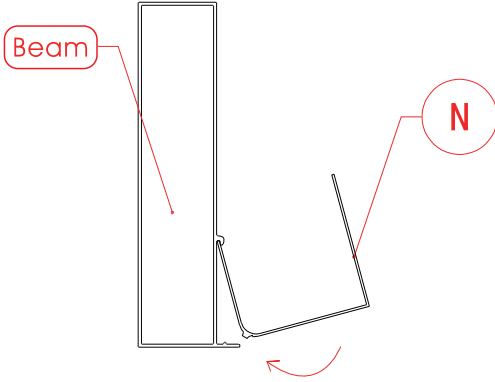
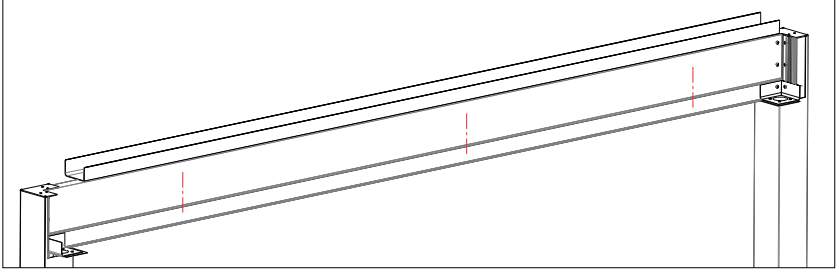

# • Install Gutter Clamp

Fix and seal the gutter clamp.

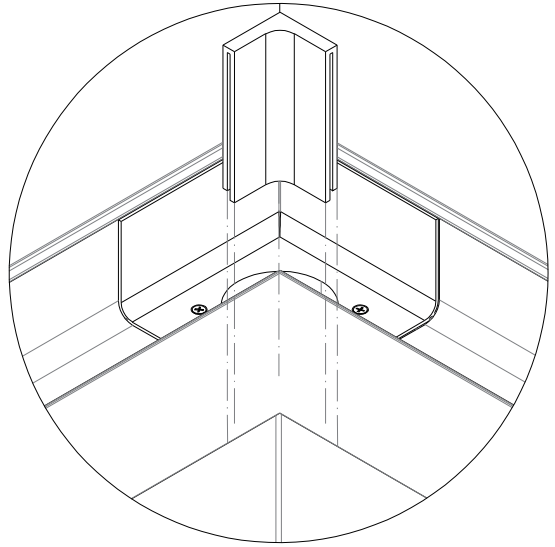

0

Gutter Clamp

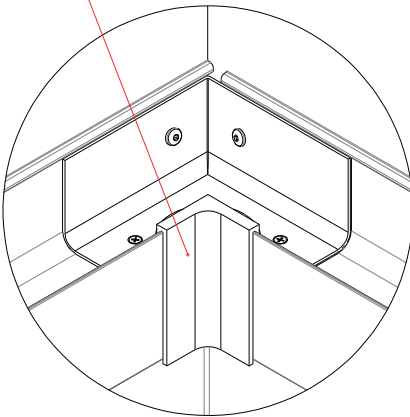

0

Gutter Clamp

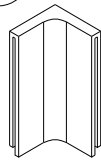

x4

# ● Sealing to waterproof

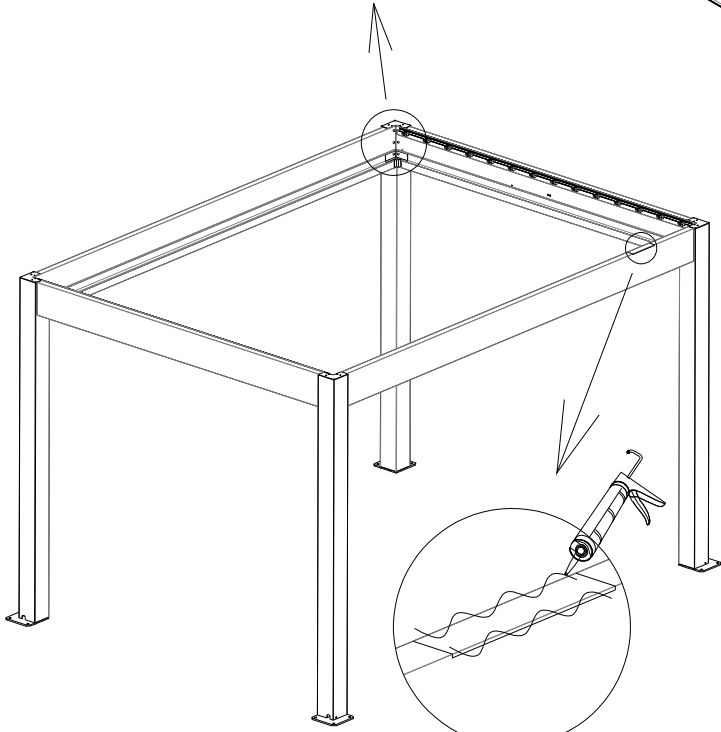
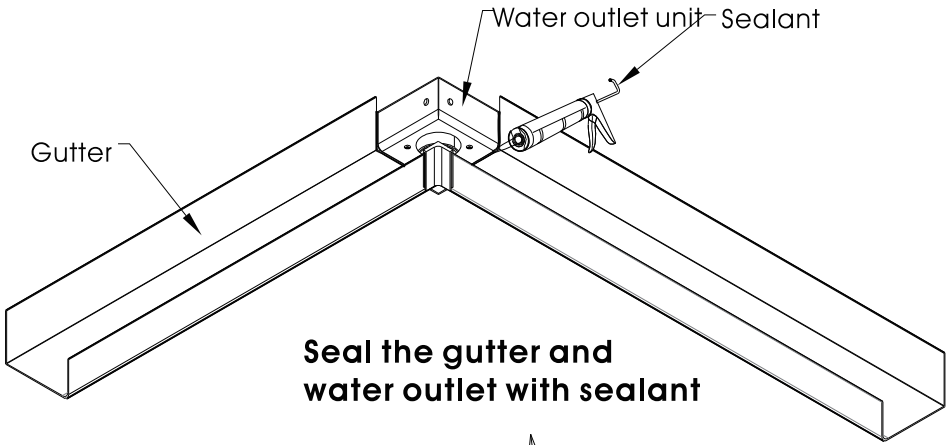

# • Install the louver blades

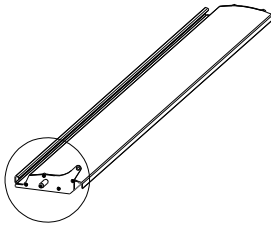

Blade without LED  
x14

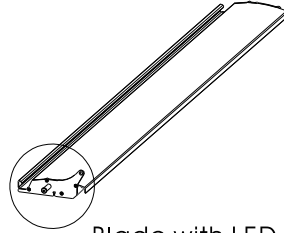

Blade with LED  
x5

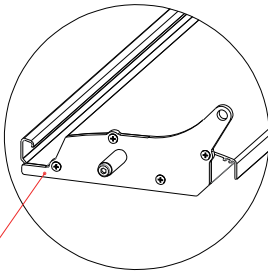

aa

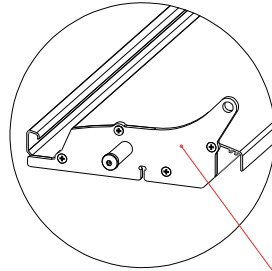

bb

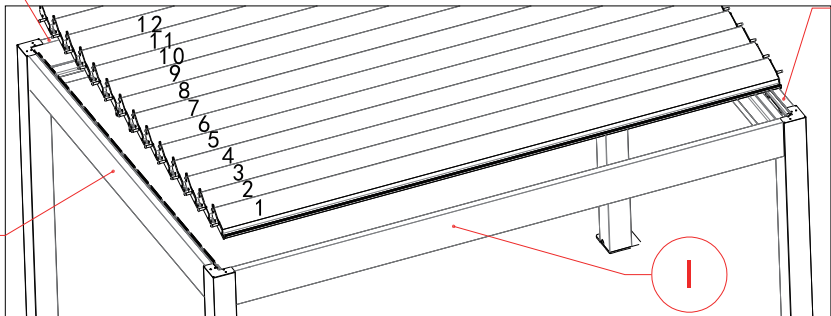

1	2	3	4	5	6	7	8	9	10	11	12	13	14	15	16	17	18	19
	■				■				■				■				■	

This layout depend on your custom pergola

bb

aa

# • Install Motor

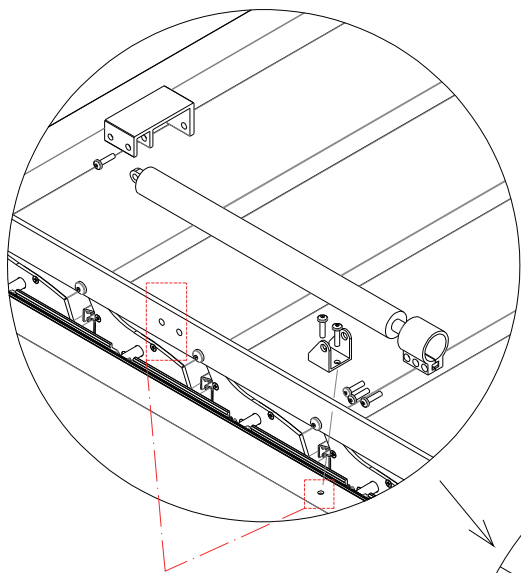

Hole for motor mounting base.

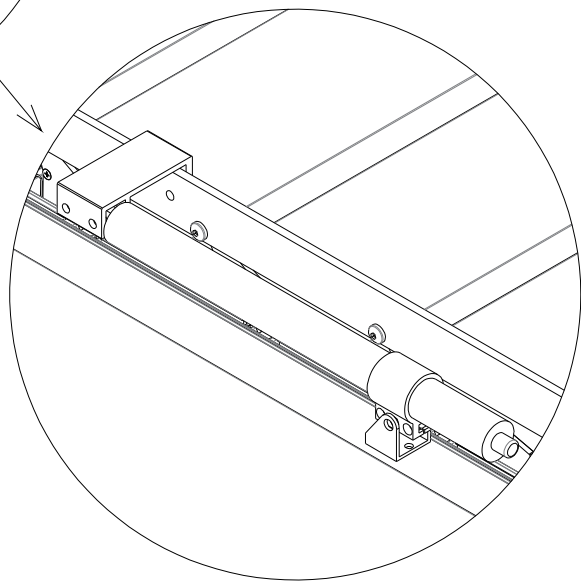

# • Motor and LED wiring

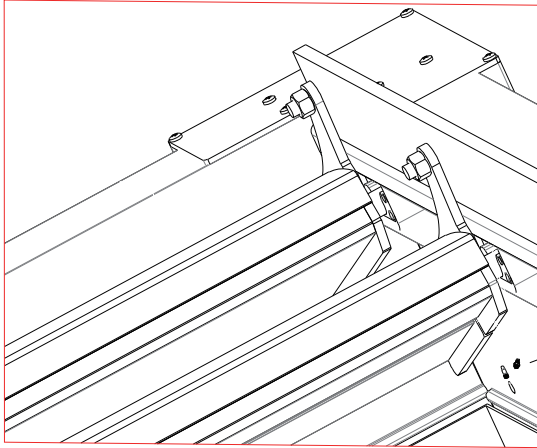

1.LED wire connect waterproof connector

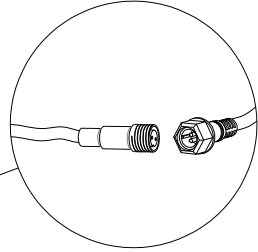

T

2. Motor connect waterproof connector

3.Snap the plastic base cover , then hide the wires to the subframe, and cover the subframe cover.

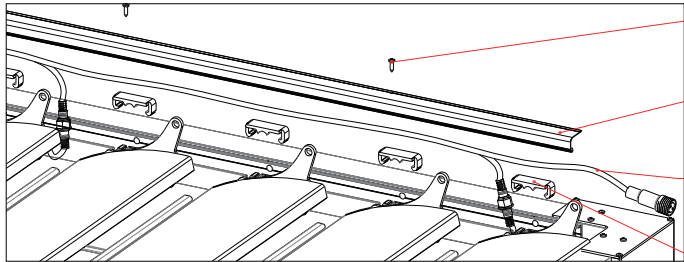
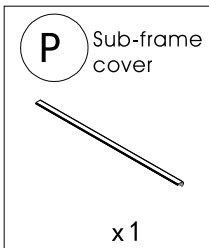
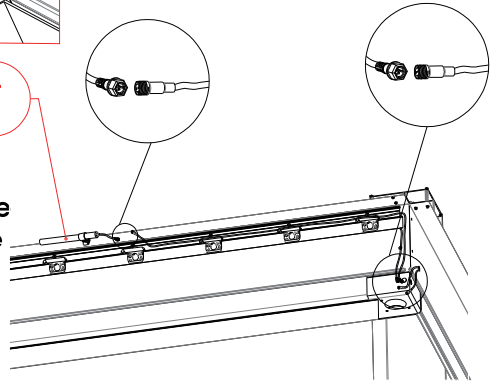

H

P

dd

Q

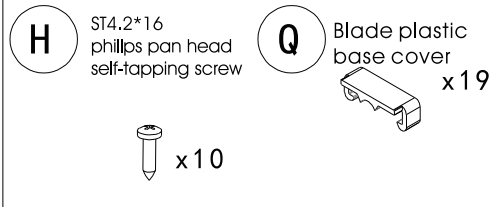

# • Install louver blade connection rod

R

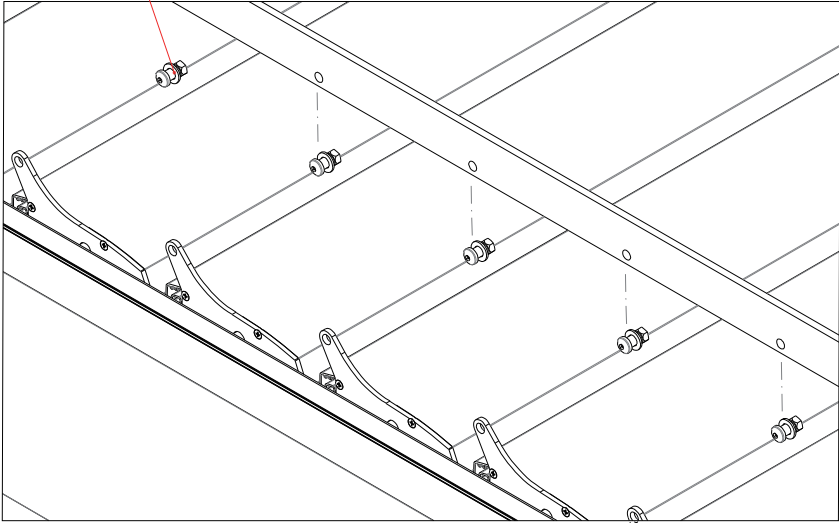

Install connection rod.

(Note: Nylon washer use between connection rod and louver blade cover).

**PLEASE do not over tighten it. make sure the louver can rotate freely before connecting to the motor**

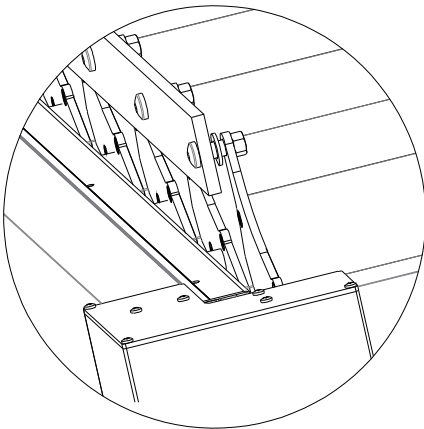

R

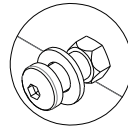

Connection Rod Screw x19

M8\*25 Pan head socket head cap screws



Stainless steel ring length 16mm



Locknut



Nylon washer

