

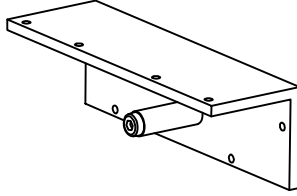

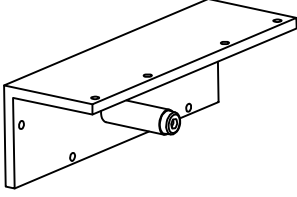
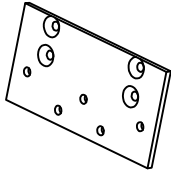
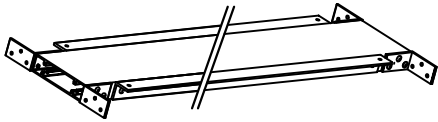
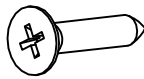

Material List

***If you are installing the fan beam.

We recommend to put it before installing other louver as

NO	Name	Picture	QTY
1	End Cap Angle Aluminium 1		1
2	End Cap Angle Aluminium 2		1
3	Aluminium Plate		2
4	Middle Beam		1
5	304 cross countersunk head screws (ST4.2*20)		8
6	304 cross pan head self-tapping screws (ST4.2*20)		30
7	304 cross pan head self-tapping screws (ST4.2*16)		18



Install End Cap

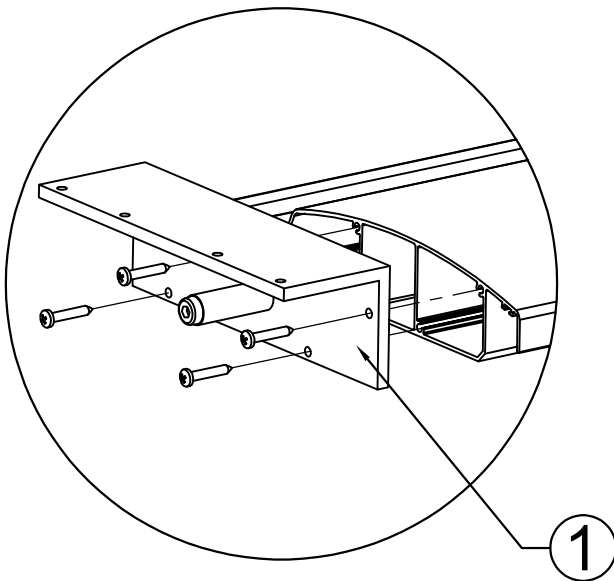
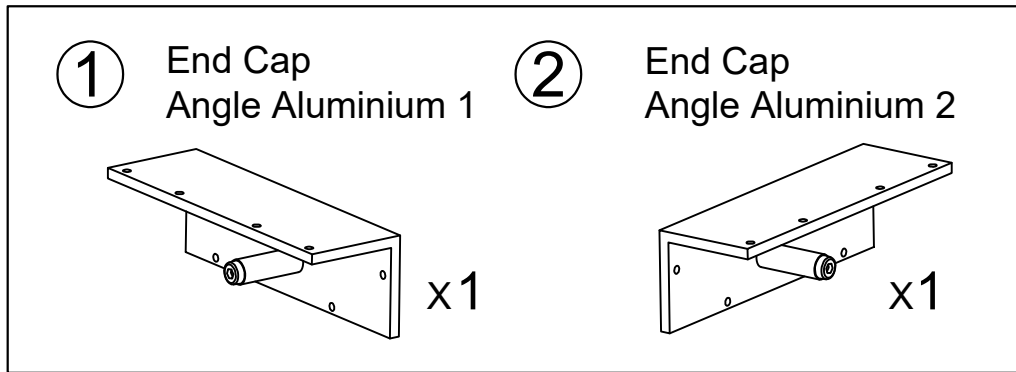

Remove the previous End Cap, use its screw to fasten End Cap, Angle Aluminium 1 and 2 to louver.

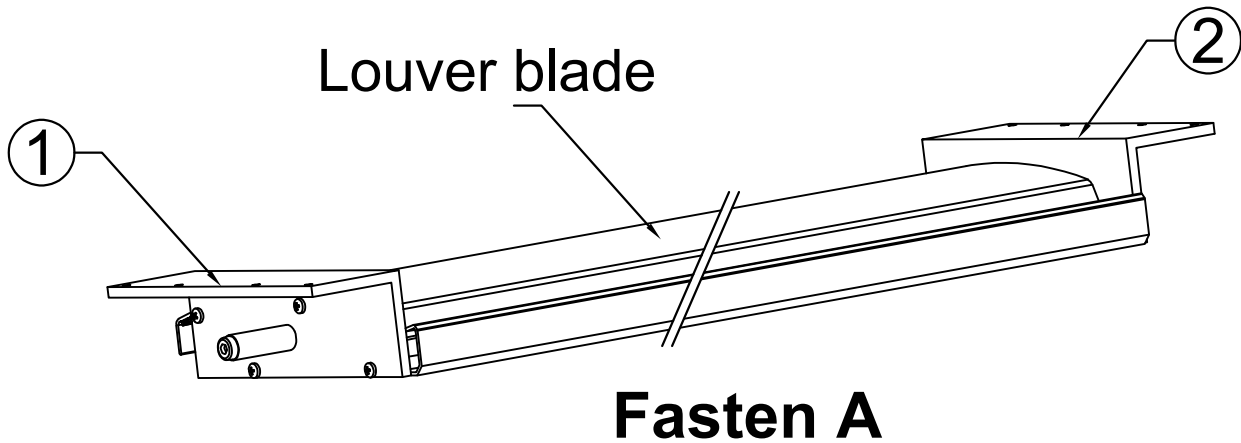



Install Aluminium Plate

③ Aluminium Plate

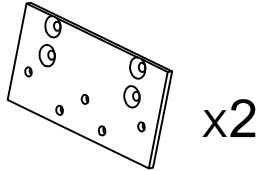

④ Fan Beam

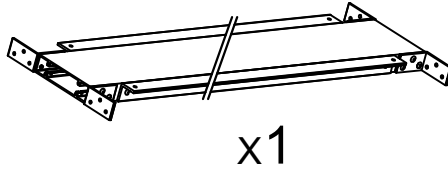

⑤ 304 cross countersunk head self-tapping screws (ST4.2*20)

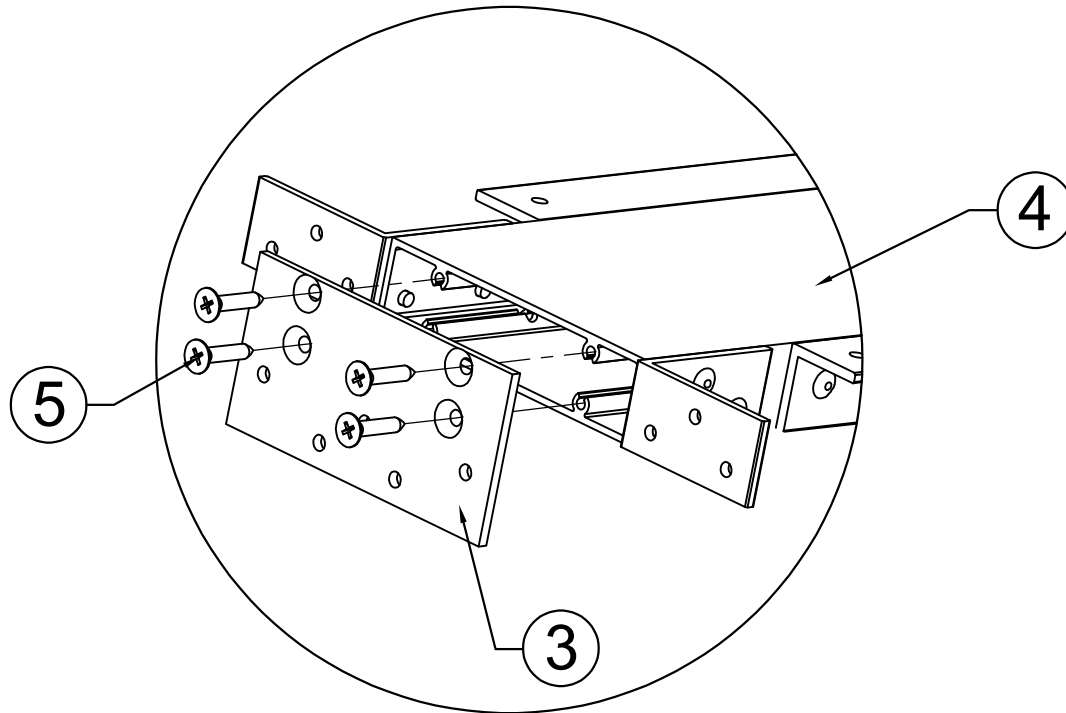

Use 304 cross countersunk head self-tapping screws (ST4.2*20) to fasten the beam and aluminium plate

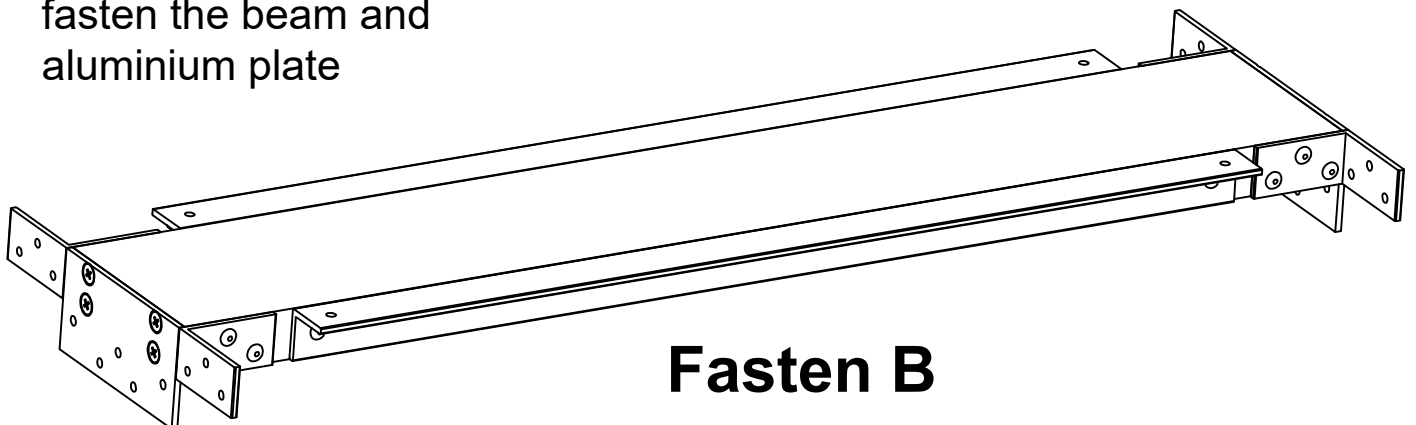



BON PERGOLA

DESIGNED IN CALIFORNIA

Fasten A

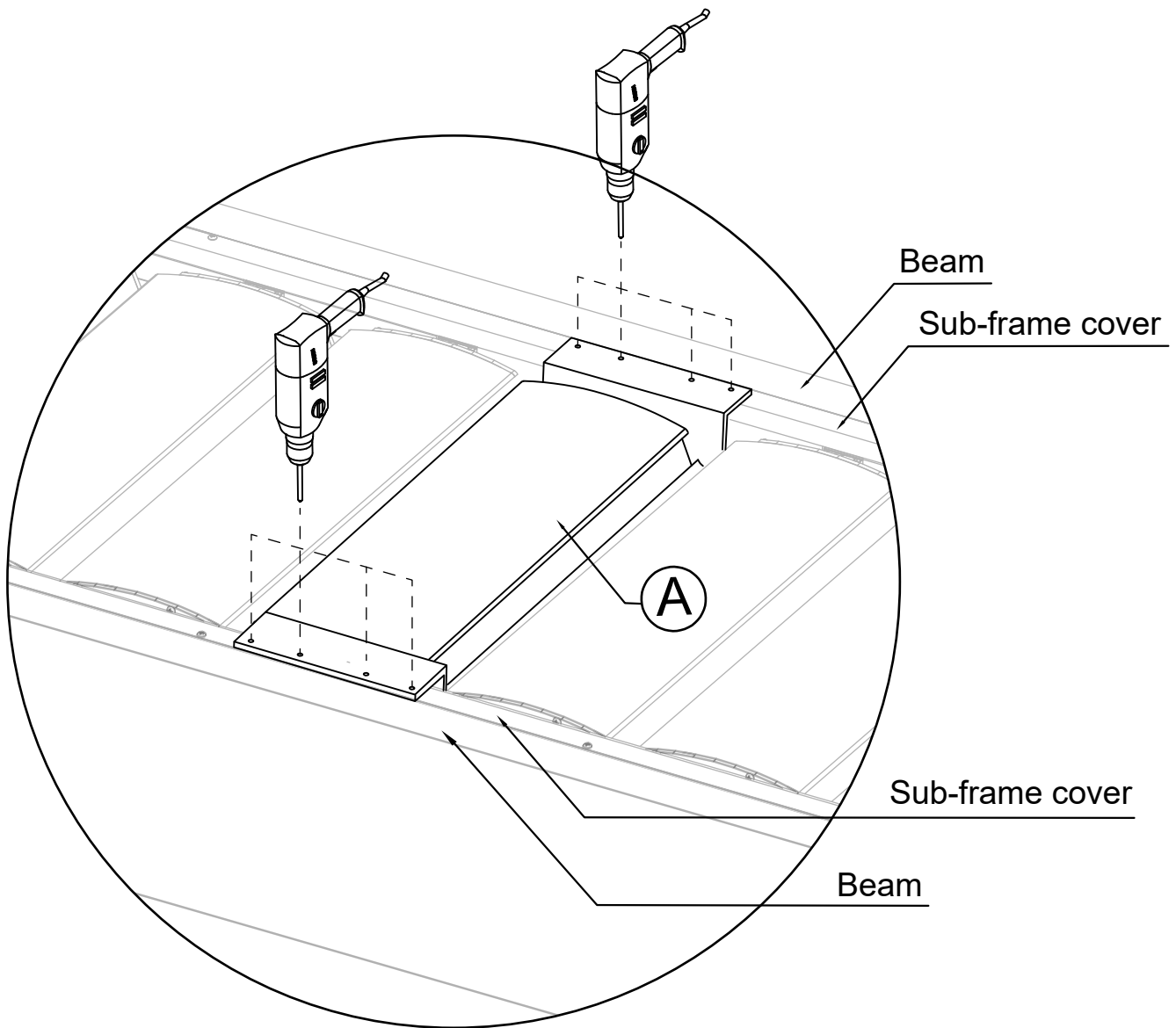
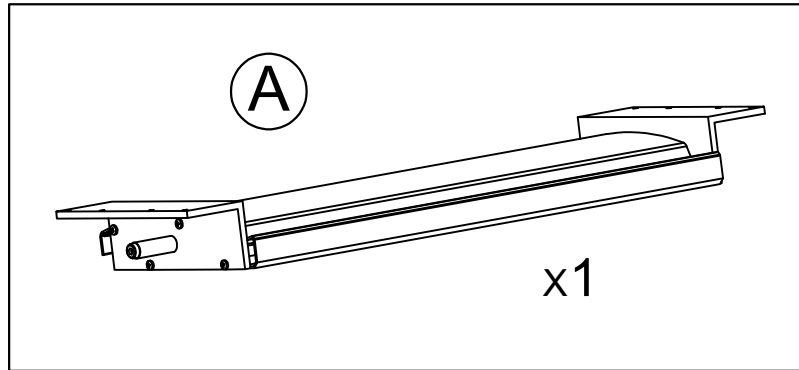

*****Mark the holes and Pre drill holes**



Fasten A

- ⑦ 304 Phillips pan head self-tapping screws (ST4.2*16)



Ⓐ

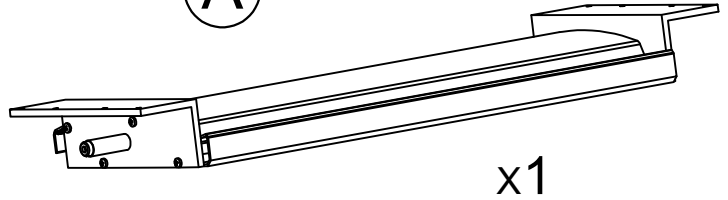

Put louver blade on the plastic base of the sub-beam, install sub-beam cover, Drill the hole in the angle aluminum of the end cover and the sub-frame and sub-frame cover

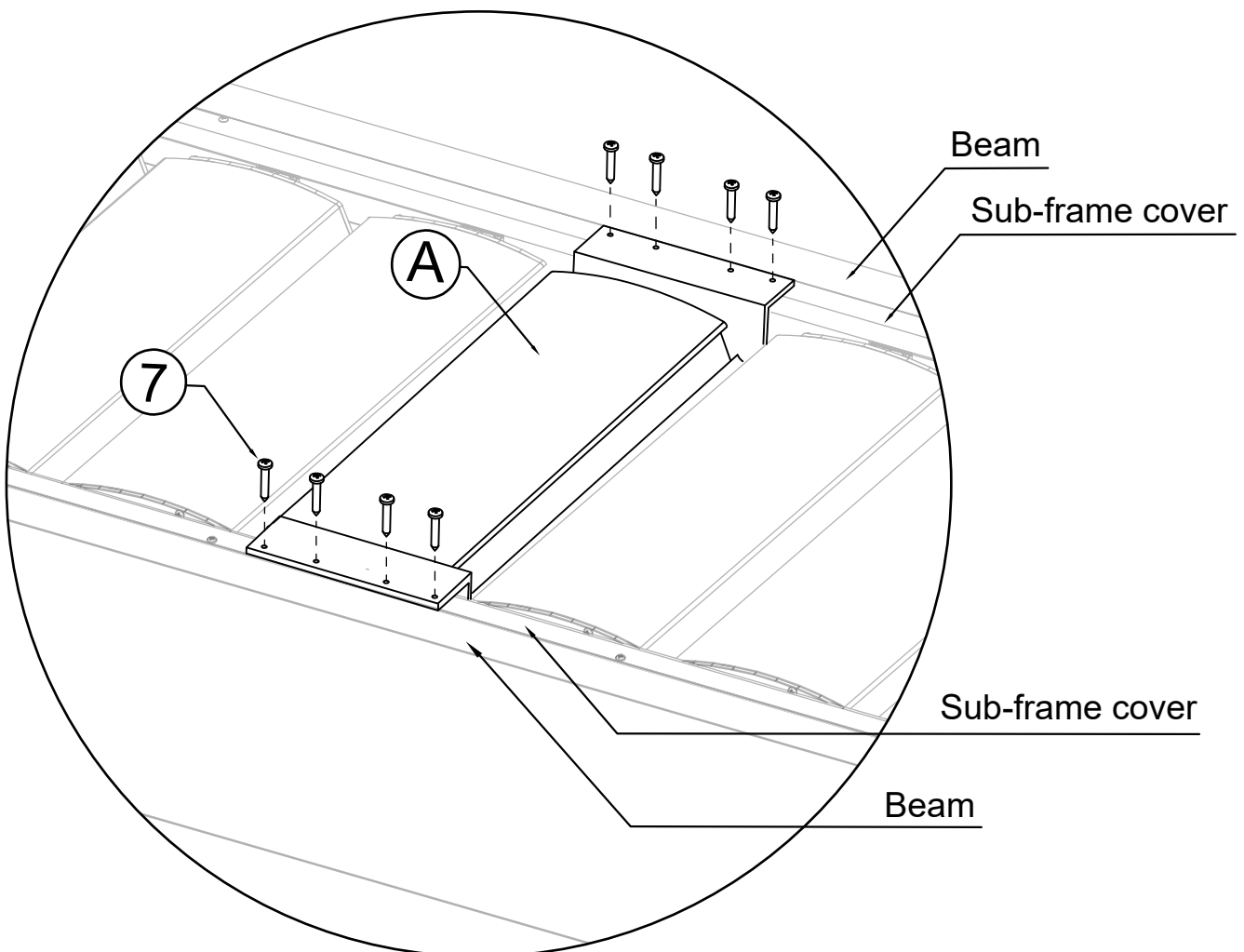

Fasten louver blade by 304 Phillips pan head self-tapping screws (ST4.2*16)



Fasten A and B

7 304 Phillips pan head self-tapping screws (ST4.2*16)

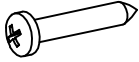

x10

B Middle Beam

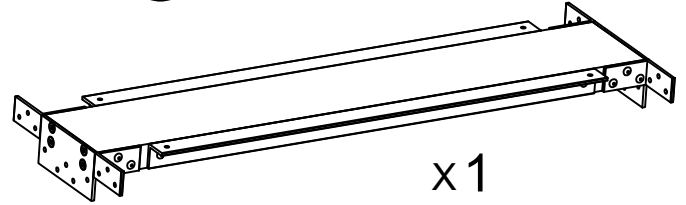

x1

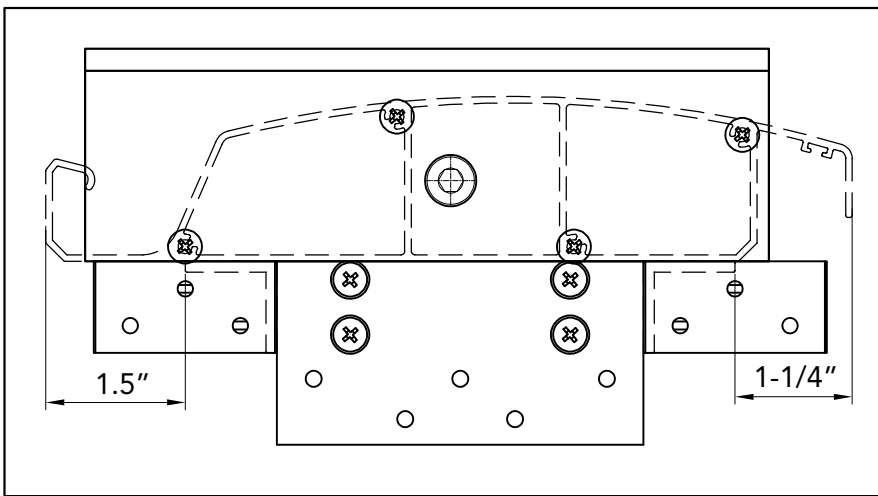

According to the distance show in this drawing, drill hole on louver blade.

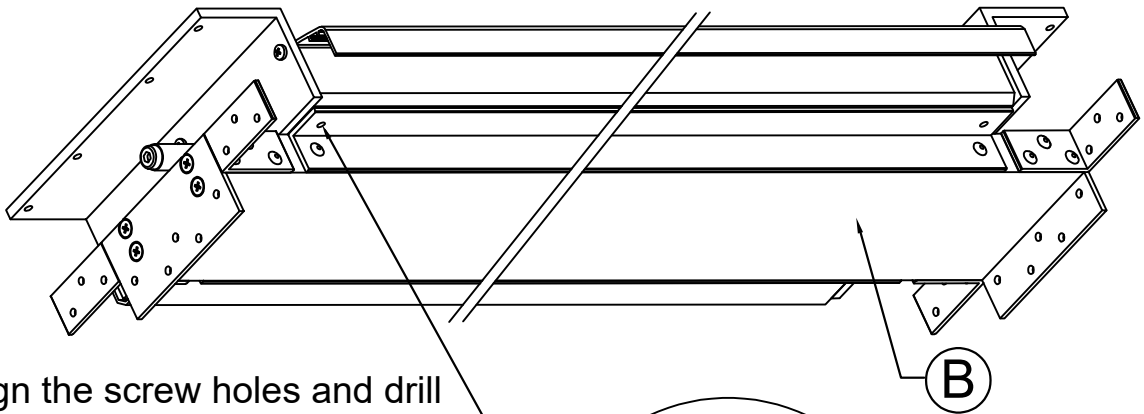

Fasten A and B by 304 Phillips pan head self-tapping screws (ST4.2*16)

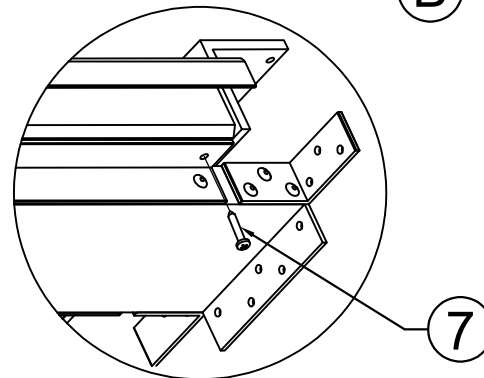

*****Mark the holes and Pre drill holes**



Fasten Middle Beam

- ⑥ 304 cross pan head self-tapping screws (ST4.2*20)

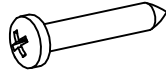

x 22

Align the screw holes at both ends of the middle beam, drill with up and down beam.

Note: At least 2 screws per location, Left/Right/Bottom 2 screws per location. If hanging heavy fan or accessories, please fasten all.

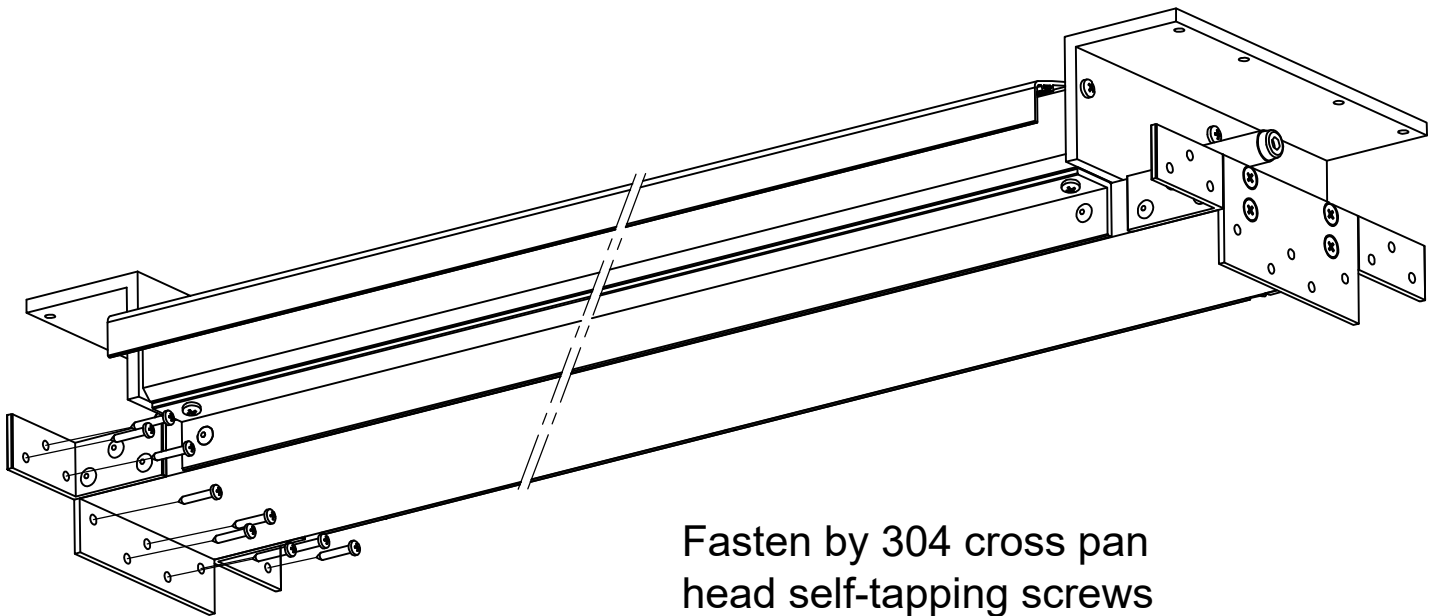

Fasten by 304 cross pan head self-tapping screws (ST4.2*20)

***** Mark the holes and Pre drill holes**