

# USER Manual

Explorer Bear  
12/24V Fridge/Freezer

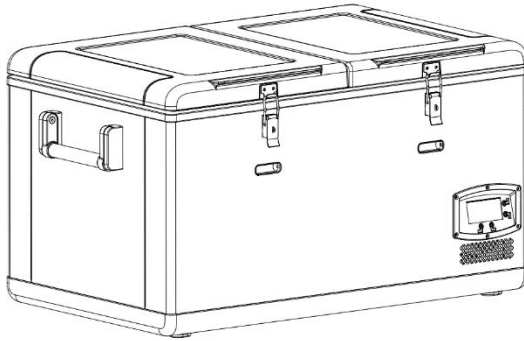

## MODEL-EX75DB /EX75DW

Customer Support  
Hotline: 1-833-275-3482  
Email: [Support@explorerbear.com](mailto:Support@explorerbear.com)

e

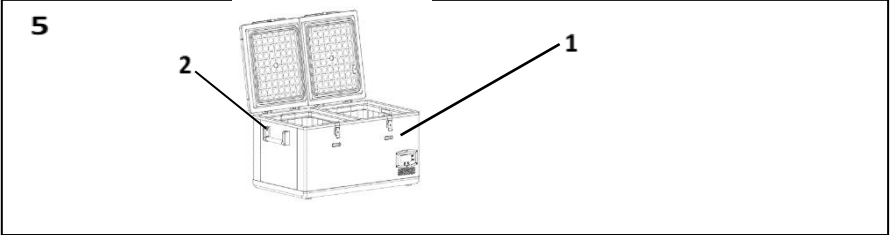
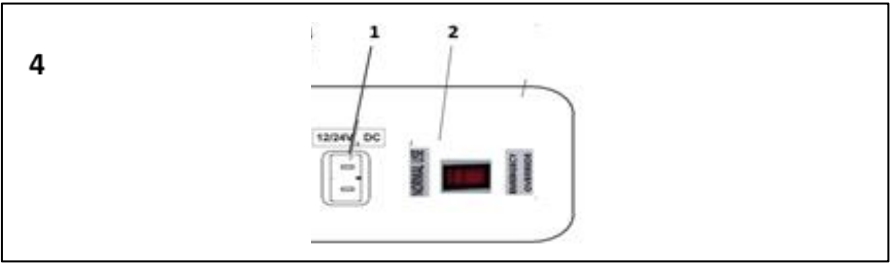
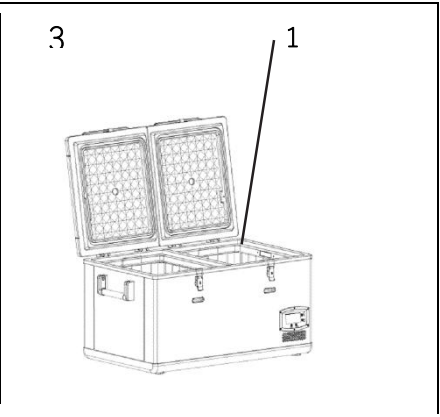
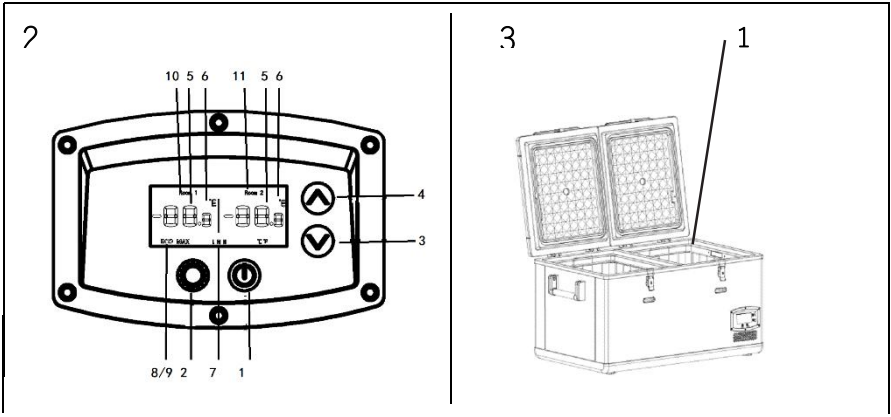
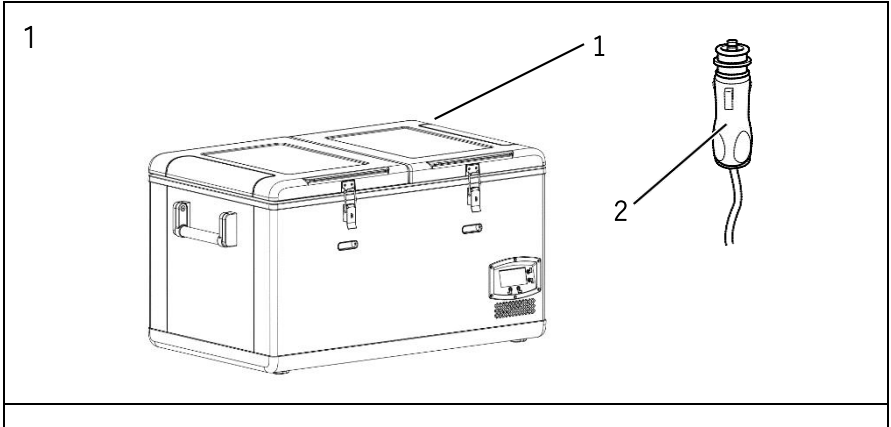

6

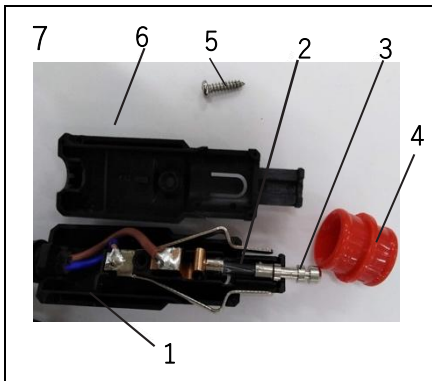
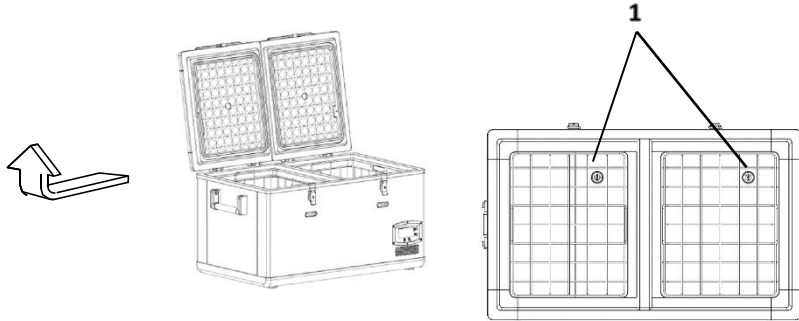

- 1.1.: Portable Compressor Freezer
- 1.2.: DC Power Cord
- 2.1.: On/Off
- 2.2.: Set
- 2.3.: Down
- 2.4.: Up
- 2.5.: Temperature
- 2.6.: Temperature Unit
- 2.7.: Battery
- 2.8.: MAX Mode
- 2.9.: ECO Mode
- 2.10.: Room1
- 2.11.: Room2
- 3.1.: Storage Box

- 4.1.: DC Port
- 4.2.: Emergency Override Switch )
- 5.1.: Lock
- 5.2.: Reset Handle
- 6.1.: Drain plug
- 7.1.: Upper Cover
- 7.2.: Fuse
- 7.3.: Contact Pin
- 7.4.: Adapter Sleeve
- 7.5.: Screw
- 7.6.: Bottom Cover

# OPERATION

## 1.1 Feature

- Three-level battery monitor: Protects the vehicle's battery by monitoring its voltage and automatic shutoff at low battery voltage
- Emergency override switch
- Switches off automatically at low battery voltage
- Displays the current temperature in either Celsius (°C) or Fahrenheit (°F).
- Set the desired temperature using the +/- buttons
- Temperature range: -18°C/0°F ~ +10°C/+50°F
- Two detachable wired baskets
- Drain plug
- Dual Zone-Fully Independent Compartments

## 1.2 Display

- |           |   |
|-----------|---|
| 1 ON/OFF  | Press and hold power button for 3 seconds   |
| 2 SET     | Selects input mode: <ul style="list-style-type: none"><li>- Set target temperature</li><li>- Set temperature unit</li><li>- Set battery monitor level</li><li>- Set Max or Eco mode</li></ul> |
| 3 - DOWN  | Press once to decrease the value  |
| 4 + UP    | Press once to increase the value  |
| 5 DISPLAY | Shows information: <ul style="list-style-type: none"><li>- Temperature</li><li>- Error Messages</li><li>- Internal voltage</li></ul>  |

# OPERATION

---

## 1.3 Select the Compartment

You have the option to set distinct temperatures for each zone or utilize just one of the two zones available in the refrigerator.

- Turn on the cooler
- Press and hold “UP ^” or “DOWN v” to turn on/off individual compartments

## 1.4 Temperature Display

You can switch between Celsius and Fahrenheit.

- Turn off the cooler
- Press and hold the “SET” button 5 seconds enter into, and press ”SET” 4 times.
- Use the “UP +” or “DOWN -” buttons to select Celsius or Fahrenheit.

The chosen temperature unit briefly appears on the display and is automatically applied. The display blinks a few times before reverting to the current temperature reading.

## 1.5 CONNECTION

The cooler can be operated with 12 V or 24 V DC.

To ensure safety, the cooler is designed with an electronic system that prevents polarity reversal. This feature protects the electric cooler from short-circuiting when connected to a battery.

- Insert the 12/24 V connection cable into the DC voltage socket, and then plug it into the cigarette lighter or a 12 V or 24 V socket.



# OPERATION

## 1.6 Using the battery monitor

The device features a multi-level battery monitor designed to protect your vehicle's battery from excessive discharge when connected to the on board 12/24 V supply.

When operating the cooler with the vehicle's ignition off, it will automatically shut down if the supply voltage drops below a specified level. The cooler will resume operation once the battery is recharged to the restart voltage level.



### **WARNING! Risk of Damage:**

When the battery monitor shuts off the device, the battery may not be fully charged. Refrain from repeatedly starting or using power-consuming appliances without allowing sufficient charging time. Make sure to recharge the battery properly.

In "H" mode, the battery monitor reacts quicker compared to "L" and "M" modes (refer to the table below).

Battery Monitor Mode	L	M	H
Switch-off voltage at 12 V	10.1V	11.4 V	11.8 V
Restart voltage at 12 V	11.1 V	12.2 V	12.6 V
Switch-off voltage at 24 V	21.5 V	22.5 V	23 V
Restart voltage at 24 V	23 V	24 V	24.5V

How to select the battery monitor mode:

- Turn on the cooler.
- Press the "SET" until battery monitor is selected.
- Use the "UP +" or "DOWN –" buttons to select the battery monitor level desired.

## 1.7.1 Using the cooler



### **WARNING! Risk of overheating:**

Always ensure adequate ventilation to allow heat generated during operation to dissipate. Keep ventilation slots clear and unobstructed. Maintain a sufficient distance between the device and walls or other objects to allow proper air circulation.

- Place the cooler on a stable & firm foundation.
- Ensure that the ventilation slots remain uncovered and allow heated air to dissipate effectively.



Position the cooler as instructed. Operating the cooler in a different orientation may cause damage.



Leaving the lid open for extended periods may result in a substantial temperature increase inside the cooler's cooling compartment.



**WARNING! Risk of Damage** from excessively low temperatures! Only place items in the cooler that are intended to be cooled at the selected temperature.



# OPERATION

---

If you plan not to use the cooler for an extended period:

- Empty the contents of the cooler and clean and dry the interior thoroughly.
- Turn off the cooler and unplug the connection cable.
- Leave the lid slightly open to allow air circulation and prevent the growth of mold or unpleasant odors.



**NOTICE! Danger of Damage:**

Avoid using sharp or pointed tools to remove ice or dislodge items that have frozen in place, as this may damage the cooler's interior or cause harm.

To defrost the cooler, follow these steps:

- 1, Remove all contents from the cooler. If necessary, transfer them to another cooling device to keep them cool.
- 2, Turn off the cooler.
- 3, Leave the lid slightly open to allow the ice to melt.
- 4, Wipe away the defrosted water or remove the drain plug to let the water flow out.

## 1.8 Using the Emergency Override Switch

The emergency override switch can be found on the control panel. During regular use, ensure that the switch is set to the "normal" position.

- In case of an electronic control failure, switch it to the "emergency override" position.



**NOTE!**

When the cooler is switched to the "emergency override" position, it will operate at full cooling capacity. Be aware that this may cause the contents inside to freeze

# OPERATION

## 1.9 Replacing the plug fuse (12/24 V)

- 1, Remove the adapter sleeve from the plug.
- 2, Unscrew the screw located in the upper half of the housing.
- 3, Gently lift the upper half of the housing away from the lower half.
- 4, Remove the contact pin.
- 5, Replace the defective fuse with a new one that has the same rating (10A, 250V).
- 6, Reassemble the plug by following the steps in reverse order.

## 1.10 Replacing the PCB light bulb

- Disconnect the power supply to the fridge.
- Using a flat and pointed tool, carefully pry out the plastic light cover.
- Unscrew the PCB mounting screws.
- Gently remove the old PCB.
- Replace it with a new PCB.
- Secure the new PCB in place using the mounting screws and a screwdriver.
- Press the transparent light cover back into its position in the housing.
- Reconnect the power supply to the fridge.

## CLEAN & MAINTENANCE

---



### **WARNING!**

Always disconnect the device from the power supply before you clean and service it.



### **WARNING! Risk of Damage**

- Avoid cleaning the cooler under running water or submerging it in dishwater, as this can cause damage.
- Do not use hard objects during the cleaning process

- Regularly clean both the interior and exterior of the device using a damp cloth. This will help keep the device in good condition and prevent dirt buildup.
- Ensure that the air inlet and outlet vents on the device are free from dust and dirt. Clear vents allow for proper heat release and prevent potential damage to the device caused by overheating.

# TROUBLESHOOT

## Error code and troubleshooting

Fault	Possible cause	Suggested remedy	
Device does not function; LED does not glow.	There is no voltage present in the 12/24 V socket (cigarette lighter) in your vehicle.	The ignition must be switched on in most vehicles to apply current to the cigarette lighter.	
	No voltage present in the AC voltage socket.	Try using another plug socket.	
	The device fuse is defective.	Replace the device fuse	
	The integrated mains adapter is defective.	This can only be repaired by an authorized repair center.	
The device does not cool (plug is inserted, "E3" lights up).	Defective compressor.	This can only be repaired by an authorized customer services representative.	
The device does not cool (plug is inserted, "E1" lights up).	Battery voltage is too low.	Test the battery and charge it as needed.	
When operating from the 12/24 V socket (cigarette lighter):  The ignition is on and the device is not working and LED is not lit up	The cigarette lighter socket is dirty. This results in poor electrical contact.	If the plug of your cooler becomes the cigarette lighter socket, either the socket must be cleaned, or the plug assembled correctly.	
		Replace the fuse (10 A) in the 12/24 V plug; see chapter "Replacing the plug fuse (12/24 V)" on page 19.	
Pull the plug out of the socket and make the following checks.		Replace the vehicle's 12/24 V socket fuse (usually 15 A). Please refer to your vehicle's operating manual.	
The device does not cool (plug is inserted, "E2" lights up "E4" lights up  "E6" lights up  "E5" is lights up	The device fan is defective.	The device PCB is defective.	This can only be repaired by an authorized repair center.
	The device NTC is defective.	Overtemperature protection.	If vents are not covered this can be repaired by an authorized repair center.