



Manufactured and Distributed by:

Hearthware, Inc.

1755 Butterfield Road, Libertyville, IL 60048, U.S.A.

Customer Service Hours:

Monday-Friday: 8:00 AM - 6:00 PM (CST)

1-847-775-8123 or 1-888-NUWAVE1 (689-2831)

www.mynuwaveoven.com / www.nuwaveoven.net / info@hearthware.com



FOR HOUSEHOLD USE ONLY

Protected under U.S. Patents : 6,201,217; 6,617,554; 6,917,017; 6,936,795; D487,670; D490,648.
International Patents: EP 1 446 981 Other U.S.A. and other International Patents Pending

Models 20201~20204, 20301~20304, 20315~20316: 120V, 60Hz, 1500Watts
Models 20221~20299, 20321~20399 : 120V, 60Hz, 1500Watts
Models 20205~20210, 20305~20310 : 230V, 50Hz, 1500Watts
Models 20213, 20214, 20313, 20314 : 220V, 60Hz, 1500Watts

© 2011 Hearthware, Inc. All Rights Reserved

IRC-01/14-W17-H



Nuwave[®]
PRO INFRARED OVEN
REVOLUTIONARY
INFRARED
COOKING SYSTEM



**THE NUWAVE[®] OVEN
COMPLETE COOKBOOK**

MANUALS + RECIPES + TIPS

WELCOME TO THE NUWAVE OF COOKING

Congratulations on the purchase of your NuWave® Pro Infrared Oven. This book contains detailed instructions and images to help you get started using your NuWave Oven. It is also filled with great recipes and time-saving tips to help you prepare delicious gourmet meals in half the time it would take when using a regular oven.

Cooking is fast and easy with the NuWave® Pro Infrared Oven from Hearthware® Home Products. This versatile countertop appliance combines infrared, conduction and convection heat to save time, energy and even calories.

The NuWave® requires neither pre-heating nor defrosting. Just place frozen food in the oven and press the buttons to program time and power level. For analog oven, simply turn dial to desired cooking time. For added convenience, the oven utilizes a layered cooking system that enables multiple foods to cook at the same time without mixing or mingling flavors.

The NuWave® Pro Infrared Oven is also a healthy choice. No fats or oils are required for cooking meat or poultry in the NuWave® Pro Infrared Oven, and its unique design drains two to three times the amount of fat drippings compared to a conventional oven. And because vegetables are cooked faster, they retain the essential nutrients that would have boiled away with a conventional stove top or oven.

We invite you to visit www.nuwaveoven.net for more cooking tips and shared recipes from NuWave Oven chefs all over the world and for more information on parts and accessories for your NuWave.

Our mission is to exceed our customers' expectations by providing innovative new products using the most advanced technology available today.



We value every NuWave customer. You've purchased your NuWave Oven because you want to save time, money and energy while enjoying healthier, great tasting meals.

To show our gratitude and lifetime commitment to you, we have created the nuwavecookingclub.com exclusively for our customers. This site will be hosted by our executive chef and will feature recipes, step-by-step instructional cooking videos, live chat and more.

You can also visit www.hearthware.com to see more innovative products developed by the makers of the NuWave Oven.

We hope you enjoy using your NuWave® Pro Infrared Oven.



THE NUWAVE® PRO OVEN

Power Head with easy-to-use controls

Dome is transparent, light weight, and highly durable

Cooking Rack
Reversible (1" or 4" Height)

Liner Pan, "Easy clean,"
Eco-friendly, non-stick enamel
(No PTFE and No PFOA)

Base can also be used
as a serving tray

Dome Holder is uniquely
designed to securely hold
your NuWave oven's dome
and power head assembly



OPTIONAL EXTENDER RING KIT:

3" Extender Ring
increases the capacity
up to 50%

10" Baking Pan
"Easy clean"
Eco-friendly
non-stick enamel
(No PTFE and No PFOA)

2" Cooking Rack
multi-layered cooking



NUWAVE OVEN PARTS AND ACCESSORIES

POWER HEADS:



ANALOG (IRC2) 22056
White with red accents



DIGITAL (IRC3) 22057
White with blue accents



DIGITAL (IRC3) 22058
White with red accents



DIGITAL (IRC3) 22059
Black with silver accents

COMPONENTS:



Dome 22016

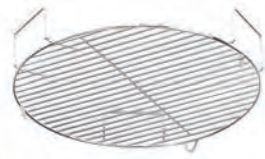

1" / 4" Reversible
Cooking Rack 22009



12" Enamel Liner Pan
22011



Dome
Holder
22020



BASE:



ANALOG (IRC2) 22061
White with red accents



DIGITAL (IRC3) 22062
White with blue accents



DIGITAL (IRC3) 22063
White with red accents



DIGITAL (IRC3) 22064
Black with silver accents

ADDITIONAL COMPONENTS:

- Extender Ring Kit (Pan, Rack & Ring) 22030
- 10" Enamel Baking Pan (only) 22024
- 2" Cooking Rack (only) 22010
- 3" Extender Ring (only) 22012

*To order call our Customer service at: **1-888-689-2831**
or order online at: www.nuwaveoven.net. Please
provide the item name and number to ensure that your
purchase is processed accurately.



PIZZA ACCESSORIES:

- The NuWave Supreme Pizza Kit (Pizza Flipper, Liner, Server and Bamboo Cutting Board) 22104
 - The NuWave Stainless Steel Pizza Flipper 22042
 - The NuWave Silicone Pizza Liner 22105
 - The NuWave Stainless Steel Pizza Server 22106
 - The NuWave 100% Bamboo Cutting Board 22107
- (see pages 18-20 for more details)

ADDITIONAL NUWAVE PRODUCTS:



The NuWave
Mini Oven
22020



The NuWave
Twister Blender
22091



The NuWave
Party Mixer
22191



The NuWave
Carrying Case
22028

INSTRUCTIONAL MATERIALS:



- The NuWave Oven Complete Cookbook 22055
- The NuWave 25 Gourmet Recipe Cards 22037
- The NuWave Quick & Easy Cooking Guide 22048
- The NuWave Instructional DVD 22040



- Additional 2-Year Extended
Warranty Coverage
Electrical Components only 22023

OWNER'S MANUALS:



- Extender Ring Kit
Owner's Manual 22054
- The NuWave Supreme Pizza Kit
Owner's Manual 22108



Registration Card 22053

TABLE OF CONTENTS

Introduction	1
Parts & Accessories	2-4
Owner's Manual	5-16
RoHS Compliant	17
NuWave Supreme Pizza Kit	18-20
Quick & Easy Cooking Guide	21-22
General Tips	23
Breakfast	24
Ham and Cheese Strata	25
Joe's Special Scramble	25
Ham and Eggs Scramble	25
Scrambled Lox	25
Chorizo Sausage & Eggs	25
Steak and Eggs	26
NuWave Muffin Sandwich	26
Oven Omelette	26
Boiled Grapefruit	26
Breakfast Casserole	27
Cinnamon Breakfast Twists	27
Low-Cal French Toast	27
Brown Sugar French Toast	28
Banana Bread	28
Appetizers	29
Baked Party Sweet Onion Dip	29
Rumaki	29
Baked Brie	30
Stuffed Italian Sausage Mushrooms	30
Chicken Kabobs with Peanut Sauce	31
Baked Reuben Sandwich	31
Ham & Cheese Pitas	31
Buffalo Chicken Wings	31
Water Chestnuts w/ Bacon	32
Chinese Style Ribs	32
Jumbo Lumb Crab Cakes	32
Crab Melt	33
Sesame Cheese Pillows	33
Teriyaki Chicken	33
Southern Style Shrimp with White Wine	33
Pizza	34
Mexican Pizza	34
Pita Pizza	35
Goat Cheese Pizza	35
Meat Crust Pizza	35
Cheesy French Bread	35
Pizza Boats	35
Mini Spinach Calzones	36
Calzones	36
Italian Pizza Patties	36
Vegetables	37
Zucchini & Onions au Gratin	38
Mexican Style Corn (Elote)	38
Italian Onions	38
Haricots Amandine	38

Vegetables Continued	38
Balsamic Glazed Carrots	38
Asparagus with Parmesan	39
Asparagus	39
Parmesan Fries	39
Roasted Herb Potatoes	39
Eggplant Casserole	40
Potatoes Au-Gratin	40
Sweet Potato Casserole	40
Double Stuffed Potatoes	41
Roasted Garlic Pate	41
Mixed Vegetable Casserole	41
Corn Soufflé	42
Parmesan Basil Tomatoes	42
Cheese Stuffed Tomatoes	42
Beef	43
Steak Diane	43
Cube Steak w/ Parsley Butter	44
Fool-Proof Standing Rib Roast	44
Meatballs	44
Japanese Style Steak	44
Sicilian Style Steak	44
London Broil in a Dish	44
Beef & Andouille Burger	45
Beefy Italian Skillet	45
Steak with Roasted Garlic and Chili Rub	46
Beef and Corn Casserole	46
Homestyle Meatloaf	46
Pepper Steak	47
German Style Beef Rollups	47
Korean Style Ribs	47
Mexican Dinner	47
Meat Loaf Italiana	47
Beef Brisket	48
Corned Beef Brisket	48
Classic NuWave Pot Roast	48
Mock Chinese Casserole	48
Lamb	49
Herb Stuffed Lamb Chops	50
Lamb and Ham	50
Lamb with Pesto	50
Lamb Kabob	50
Moroccan Lamb Burgers	51
Curried Lamb	51
Lamb Chops w/ Feta	51
Poultry	52
Stuffed Chicken w/ Goat Cheese and Red Pepper Sauce	53
Cilantro Garlic Chicken	54
Chicken & Dumpling Casserole	54
Breaded Chicken Breast	55
Nut Breading Chicken Breast	55
Thai Chicken	55
Chicken Breast Italiano	55
Lemon Chicken	55

Poultry Continued	56
Creamy Chicken Breast with Mushroom & Peppers	56
Buttery Chicken Breast	56
Chicken Curry	56
Rosemary Chicken	56
Chicken Servings with Salsa	57
Lemon Caper Chicken	57
Oven Fried Chicken Tenders w/ Wasabi Dipping Sauce	57
Crunchy Filled Chicken	58
Turkey Breast Enchiladas	58
Caraway Duck with Raspberry Sauce	58
Pork	59
Adobo Cutlets	59
Pork in Mole Sauce	60
Baked Ham in Cola	60
Asian Marinated Pork Chops	60
Glazed Spareribs	61
Chilled Pork Chops	61
Italian Sausage with Peppers	61
Thai Pork Tenderloin	62
Pork Chops w/ Mustard Sauce	62
Kielbasa Casserole w/ Rice	62
Seafood	63
Artichoke Topped Tilapia	64
Snapper with a Snap	64
Ancho Chili Crusted Salmon	64
Bass with Fennel	64
Tuna w/ Fresh Orange Salsa	65
Peppered Tuna w/ Hoisin	65
Cheesy Crab Melts	66
Sweet Chili Scallops	66
Simple Sole	66
Shrimp in Spiced Beer	66
Shrimp with Lemon	66
Shrimp Dijon	67
Lemon Salmon w/ Mango	67
Lobster Tail with Crawfish	68
Lobster Thermidor	68
Clams & Sausage	68
Shellfish Medley	68
Grilled Calamari	68
Vegetarian	69
Stuffed Peppers with Barley	70
Grilled Vegetable Quesadillas	70
Tomato and Olive Tart	71
Tofu Teriyaki	71
Taco Pie	71
Ricotta Spinach Rolls	72
Peppers w/ Herbs & Tomatoes	72
Desserts	73
Cinnamon Pecan Bites	73
Pound Cake	74
Apple Crisp	74
Baked Apples	75
Jen's Brownies	75

Desserts Continued	76
Lemon Drizzle Coffee Cake	76
English Toffee Bars	76
Lemon Squares	76
Right Side Up, Upside Down Pineapple Cake	77
Nana's Shortbread Cookies	77
Caramelized Pineapple Sundaes	77
Bread Pudding w/ Whiskey	78
Almond Tart	78
Top Crust Only Pies	78
Easy Low-Fat Apple Pie	79
Easy Low-Fat Cherry Pie	79
Snacks	80
Taco-Flavored Chicken Wings	81
Chicken Nachos	81
Taco Pie Casserole	81
Pecan Hot Dip	82
Sweet Potato Chips	82
Zucchini Bran Muffins	82
Hawaiian Cheese Bread	83
Sausage Balls	83
Pesto Sauce	83
Hollandaise Sauce	83
Dehydrated Beef	84
Trail Mix	84
Spiced Pecans	84

CONTENIDO

Manual Del Usuario	85-97
Normas RoHS	98
NuWave Supreme Pizza Kit	99-101
Introducción	102
Tabla de Preparacion Rapida y Facil	103-104
Recomendaciones	105-107
Recetas	107-112
Huevos con Chorizo	107
Cangrejo Fundido	107
Elote Estilo Mexicano	108
Papas a la Parmesana	108
Camarones a la Cerveza	108
Albóndigas	108
Cena Mexicana	109
Pollo al Romero	109
Pechuga de Pollo a la Mantequilla	109
Pollo al Limón	110
Muslos de Pollo Fritos	110
Camarones con Limón	110
Enchiladas de Pechuga de Pavo	110
Cerdo en Mole	110
Pizza Mexicana	111
Calzones	111
Carnitas	111
Helado de Piña Caramelizado	111
Manzana Crujiente	112
Tacos de Salmón	112

IMPORTANT SAFEGUARDS

When using electrical products, especially when children are present, basic safety precautions should always be followed.

READ ALL INSTRUCTIONS BEFORE USING

DANGER – To reduce the risk of electrocution:

1. Read all instructions, safeguards, and warnings before using the appliance.
2. Do not place appliance where it can fall or be pulled into water or other liquids.
3. Do not reach for an appliance that has fallen into water. Unplug immediately!
4. Do not immerse cord, plug, or power head in water or other liquids.

WARNING – To reduce the risk of burns, electrocution, fire, or injury:

1. This appliance should not be used by children. Close supervision is necessary when this product is used near children.
2. Do not use this appliance for anything other than its intended use. Do not use any other accessories or attachments not recommended by the manufacturer. They may result in fire, electrical shock, or personal injury.
3. Never operate this appliance if it has a damaged cord or plug, is not working properly, has been dropped or damaged, or dropped into water. Return the appliance to an authorized customer service center for inspection, repair, or adjustment.
4. Keep the cord away from heated surfaces.
5. Always unplug power cord by pulling on the plug. DO NOT unplug by pulling on the cord.
6. Never force the plug into an outlet.
7. Do not operate outdoors or operate where aerosol (spray) products are being used or where oxygen is being administered.
8. Do not let the cord hang over the edge of the table or counter.
9. Do not place on or near hot gas or electric burner or in a heated oven.
10. Do not move the appliance while it contains hot food. Use extreme caution when removing hot liner pan or cooking rack.
11. Before removing plug from the wall, turn the unit off first.
12. Check all electrical wiring. Beware of damaged cord or plug.
13. This appliance is for household use only; it is designed to process normal household quantities. It is not suitable for continuous or commercial operation.



14. Do not disassemble the product. There are no user serviceable parts.
15. Do not leave the appliance unattended while in use.
16. Use the handles when lifting the dome from the base.
17. Do not touch hot surfaces. Use the handles provided or use oven mitts.
18. Stop or pause cooking before removing the dome to check or turn food. The dome and power head should be placed on the dome holder.
19. Always remove the dome away from you so the escaping steam is channeled away from your face.
20. If the power cord is damaged, it should be replaced by a special cord or assembly from the manufacturer or its service agent.
21. Use caution when disposing of hot grease.
22. Keep this manual handy for easy future reference.
23. Do not use this appliance for anything other than it is intended.

SAVE THESE INSTRUCTIONS

ELECTRICAL INFORMATION:

The cord length of this appliance was selected to reduce Safety Hazards that may occur with a long cord. Extension cords are available and may be used if care is exercised in their use. If an extension cord is used: (1) the marked electrical rating of the extension cord should be at least as great as the electrical rating of the appliance, and (2) the longer cord should be arranged so that it does not drape over the counter or table top where it could be accidentally pulled off the counter or table or tripped over.

Certain models of the appliance may have a polarized plug (one blade is wider than the other). This plug is intended to fit into a polarized outlet only one way. If the plug does not fit fully into the outlet, reverse the plug. If it still does not fit properly, contact a qualified electrician. Do not attempt to modify the plug in any way.

	 WARNING
	Electric shock hazard. Use with adequate electrical system. Do not use if cord or plug is damaged. WARNING: All metal items in the oven, such as the liner pan and cooking rack can get very hot during cooking. Please be careful when removing these items from a hot oven. Always wear oven mitts or use pot holders. Allow liner pan and cooking rack to cool completely before cleaning. The dome opening may expand slightly when hot. In rare instances, the power head could detach itself from the dome completely thereby causing hot air to escape from between the dome and the power head.

PARTS/ASSEMBLY DIAGRAM

Digital Control Panel
NuWave Oven Pro

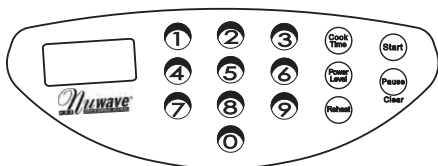

Analog Control Dials
NuWave Oven

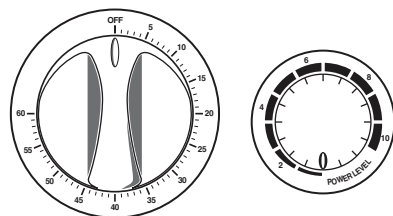

Power Head with easy to use controls

Handles

Dome is transparent, light weight, and highly durable

Cooking Rack Reversible (1" or 4" Height)

Liner Pan, "Easy clean," Eco-friendly, non-stick enamel

(No PTFE and No PFOA)

Base can also be used as a serving tray

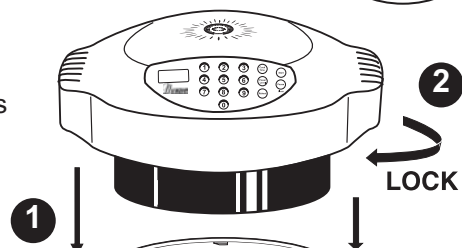

Optional 3" Extender Ring Increases the capacity of the NuWave oven up to 50%. (see illustration on pg.10)

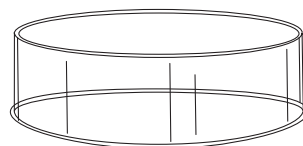

Dome Holder is uniquely designed to securely hold your NuWave oven's dome and power head assembly

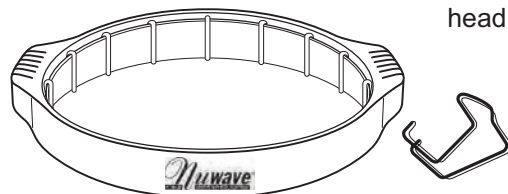

BEFORE USING:

Before using wash dome, liner pan, base, and cooking rack in warm soapy water or clean in the dishwasher.

IMPORTANT - Do not wash or immerse power head in water or in dishwasher. The outer surface can be cleaned by wiping carefully with a damp dishcloth or sponge.



ASSEMBLY:

- Place base tray on a firm stable surface.
- Place liner pan inside base tray. When placing liner pan inside the base tray, make sure the handles are positioned at the dropped down position. If the handles are not fully dropped down, the dome may not fit over the base properly. (see illustration on pg. 9)
- Place dual level cooking rack on the liner pan according to cooking requirements.
- Place food on the cooking rack.
- Place dome over food and on to base tray. The dome should fit on to the base evenly.
- Place power head into the rim of the dome and lock it into place by rotating the power head clockwise until the locking lugs are engaged.
- Set cook time and power level according to cooking requirements.

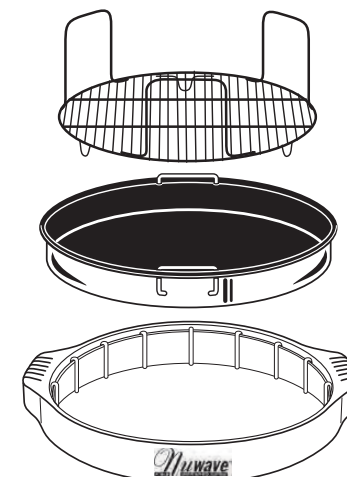

GENERAL USE INSTRUCTIONS:

- Make sure the unit is safely plugged into a properly grounded outlet and that the cord is not touching any hot objects.
- Make sure that the liner pan has been placed within the base.
- Do not place the liner pan directly onto a stove burner or direct heat source. Damage may result.
- Metal or glass dishes, pans, and foil or anything used in a regular oven may be safely used within the NuWave Oven.

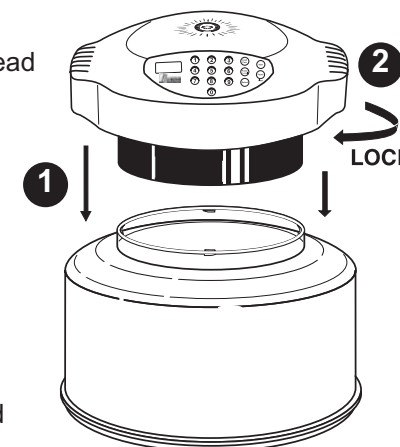

HOW TO OPEN POWER HEAD AND DOME ASSEMBLY

Make sure the power head is tightly locked on to the dome, then the whole assembly can be easily lifted and put aside as shown in steps 1, 2 and 3.

Step 1: Place dome holder under either side of base handle.

Step 2: Make sure both feet of the dome holder are placed inside the handle, and the dome holder is resting horizontally on a flat surface.

Step 3: Place the assembled power head and dome at a 45° angle on the dome holder as shown.

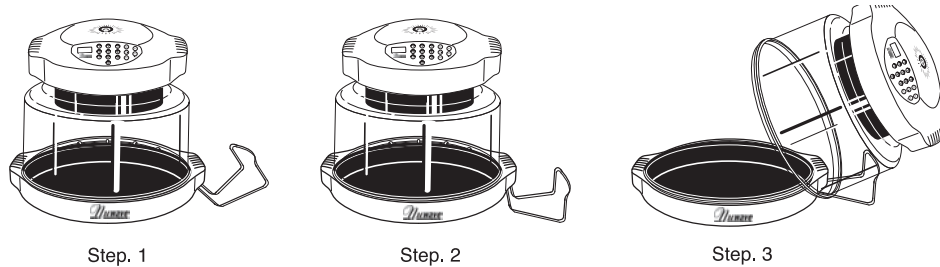

COOKING INSTRUCTIONS

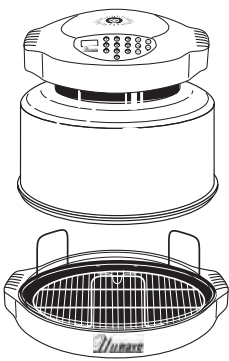

Lift dome only by the handles on the power head. Once the power head and the dome is assembled, the handles of the power head will allow you to lift both together when removing or checking food.

When removing liner pan while it is still hot, be extremely careful and always use oven mitts. The retractable handles are provided for this purpose.

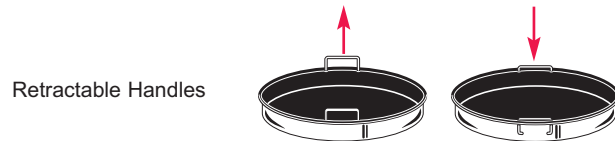

Retractable Handles

For best results, follow the time, power, and cooking rack height instructions given in the cooking chart and the recipe book.

No pre-heating required.

CAUTION
<p>Do not touch the dome or any surface on the cooking area during operation. The air inside the dome can reach 342°F (172°C) which makes the surface very hot and may cause burns.</p> <p>Do not open the dome or remove the power head while it is still operating. Turn the cook time dial to "OFF" first to turn off the power before removal, or if digital oven, push "PAUSE".</p>

MODELS CONTAINING 3" RING

If your oven included a 3" Extender Ring, the Extender Ring for the NuWave Oven can be used for multi-level cooking with the various racks or with oversized food items that might not normally fit under the standard dome. Generally, any food item (such as a ham or turkey) that exceeds 10 lbs. would require the use of the Extender Ring for optimal cooking.

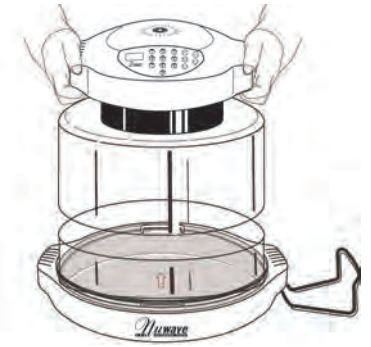

DIRECTIONS:

The Extender Ring should be positioned between the original dome and the base. The addition of the Extender Ring will expand the NuWave Oven's available cooking space by approximately 440 cubic inches. When adding the Extender Ring to the NuWave Oven, make sure the Extender Ring fits snugly onto the dome. When the ring is placed under the dome incorrectly the overlapping edges will not fit together properly. Please use caution when using the ring. If improperly used, heat or steam could escape from the oven possibly burning your skin or altering the cooking time. The Extender Ring should only be used as an accessory item to the NuWave Oven and not be used as a replacement for the dome, base, or any other components of the NuWave Oven.

MODELS CONTAINING EXTENDER RING KIT:

2" Rack:

The 2" Rack for the NuWave Oven can be used in a variety of ways:

1. It can be the primary rack with or without the extender ring.
2. With the Extender Ring, it can be positioned on top of the 4" Rack or under the 4" rack for more multi-level cooking space.
3. Without the Extender Ring, the 2" Rack can also facilitate multi-level cooking by creating a third cooking surface between the liner pan and under the 4" rack.
4. You may use two extra 2" racks above and below the 4" rack, especially good for dehydrating.

Note: The 2" rack is only to be used in the positions and purposes shown on page 11. Any other uses may affect cooking time and quality.

CARE & USE:

Similar to the original dome, the Extender Ring is constructed from high-impact Lexan polycarbonate. It should not be cleaned with any harsh abrasive but it is also dishwasher safe. The rack is dishwasher safe but should not be cleaned with any harsh abrasives.



GENERAL RULES :

- Place foods that need a long time to cook on the rack closest to the heating element like potatoes, carrots, etc. and place soft vegetables on the lower racks, like mushrooms, tomatoes, etc. -OR- Reverse the order and place longer cooking foods on liner pan and NuWave until almost done. Then place faster foods above and continue until all levels are done.
- Use food combinations that take about the same time for each to cook. For example: pork or chicken and potato wedges; fish and stewed tomatoes; or frozen beef with baked potatoes.
- Place tin foil under any foods that might drip onto other foods.
- Remember that the infrared rays do not penetrate the aluminum but the heat will circulate throughout the oven.
- If top layers are done earlier, remove rack(s) from above and continue cooking bottom foods until done.
- Use shallow dishes or light aluminum pans for cooking.
- For warming bread, place it on the bottom rack or liner pan and cover. For grilling bread, place it on the top rack.



DIRECTIONS FOR DIGITAL NUWAVE OVENS

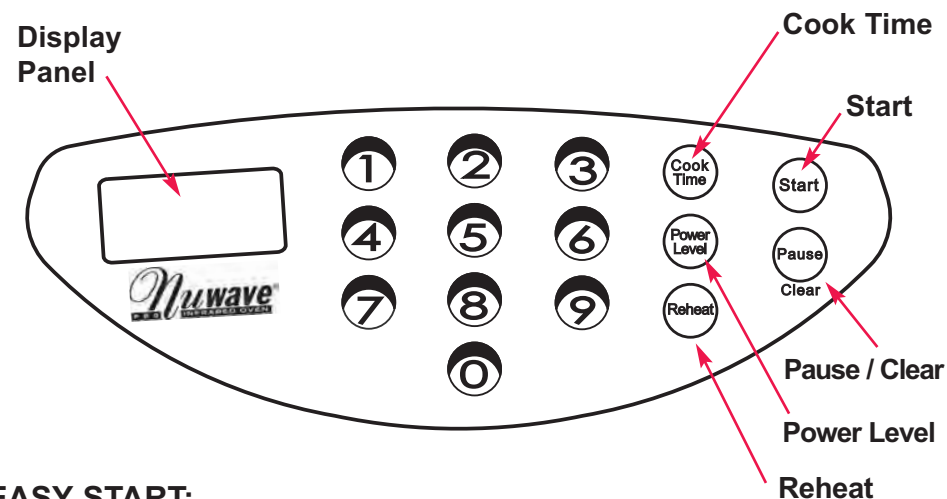

EASY START:

Oven is preset to cook at Power Level 10

To start cooking, press **COOK TIME** button, enter time required, and press **START**. If cooking at any other power level other than HI (10), Power Level button will be needed. See “Setting Power Level”.

CONTROL PANEL ON POWER HEAD - “0” should appear in window when program is clear.

SETTING COOK TIME:

Press the **COOK TIME** button. The MIN indicator will flash in the lower right corner of the display panel. Enter the required time in hours and minutes by pressing the corresponding numerals. For example, 1 hour and 30 minutes would be entered by pressing 130. The display panel will show 1:30. If required time is in minutes, you only need to enter 1 or 2 numbers. For example, 5 minutes, just push 5; 46 minutes, push 46. If the number needs to be corrected, clear the entry by pressing pause/clear button twice. Then re-enter the correct numbers.

START COOKING:

Press **START** to begin cooking. The remaining cooking time will appear in the display panel and the colon between the hours and minutes will blink ON and OFF. The oven will automatically stop cooking when the time has expired and will **beep** to alert you that it has stopped.

PAUSE/CLEAR COOKING:

To **PAUSE** the cooking time, press the **PAUSE / CLEAR** button one time. The remaining cooking time will stay in the display panel but the colon will not be blinking.

During the cooking, to **CLEAR** the cooking time, press the **PAUSE / CLEAR** button twice. The remaining cook time will be fully cleared and a “0” will appear.

SETTING THE POWER LEVEL:

- Press the **POWER LEVEL** button.
- The default “HI” setting is indicated in the display panel (power level 10).
- PWR indicator flashes in the display panel. To override the default and change the power level, just press the desired cooking power: 1 (low power) to 9 (near high power). The power is entered as a single digit.
- **To reset to HI, press 0.**
- Verify the correct power setting on the control panel.
- If power setting needs to be corrected, re-enter the required number.
- To check power level during cooking, press **POWER LEVEL** once and setting will appear on the display panel for a few seconds. Remaining cooking time will then re-appear.

NOTE: Maximum allowed cook time for **HI power is 2 hours**. If cooking time is set to more than that, it will automatically revert back to 2:00 hours. Simply add more time after the initial 2 hours has expired. For **lower power settings**, maximum allowed time is **9 hours 59 minutes**.

***Do not press Power Level unless you want to change the Default setting (power level 10).**

Power Level	Oven Temperature	Press Button	Panel Display
10(HI)	342°F (172°C)	0 (High)	PHI
9	325°F (163°C)	9	P90
8	300°F (149°C)	8	P80
7	275°F (135°C)	7	P70
6	250°F (121°C)	6	P60
5	225°F (107°C)	5	P50
4	175°F (79°C)	4	P40
3	150°F (66°C)	3	P30
2	116°F (47°C)	2	P20
1	106°F (41°C)	1 (Low)	P10

REHEAT FUNCTION:

This can be used to reheat single portion sized foods. To activate the reheat function, make sure program is clear (**PAUSE / CLEAR** button). LCD will read 0. Press **REHEAT** button and then press the **START** button. This will program power level HI for 4 minutes. Alarm will beep when time has expired. Example, if you are reheating left over pizza, simply place the slice on the 4” rack, press **REHEAT**, and then **START**. If you reheat a rice or noodle dish, place the single serving amount on an oven safe dish or on a piece of foil. If you want the rice or noodles softer, cover with foil and add a sprinkle of water.

DIRECTIONS FOR ANALOG NUWAVE OVENS

SETTING COOKING TIME:

Cook time dial is located on the front of the power head. You can turn the cook time dial to the desired cooking time. The power indicator light will come on. As time lapses, the dial will return to “OFF” position. The maximum cooking time is one hour. During cooking, you can add or reduce the cooking time by turning the cook time dial. Same as with all mechanical timers, for accuracy, **turn the cook time dial past the desired time, then turn it back to the desired setting**. For example: If the desired time setting is 5 minutes, then turn the cook time dial to 10 minutes, then turn back to 5.

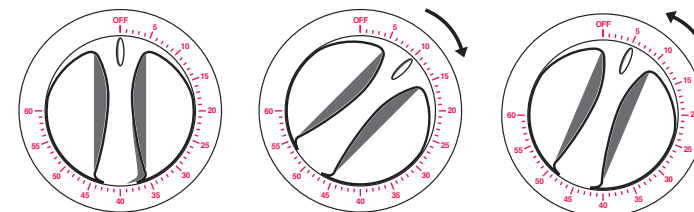

Important: For U.S.A. models, before checking or removing food, turn the cook time dial to “OFF” to turn off the heating power. **DO NOT OPEN OR REMOVE POWER HEAD WHILE IT IS STILL OPERATING.**

SETTING COOKING POWER LEVEL:

- Power level dial is located on the front of the power head.
 - Turn the power level dial to the desired power setting, from 1 to 10 (HI).
 - You can adjust the power higher or lower during cooking.
- * Power Setting is different from Digital Oven.

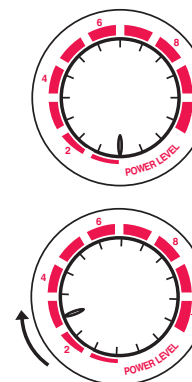

TO START COOKING:

Set the cook time dial to desired setting (As with any timer, you may want to turn the dial **past the desired time** and then turn back to desired setting).

TO PAUSE/END COOKING:

Turn the cook time dial to “OFF”, bell rings, and cooking stops.

Note: For some models, when the power head is lifted and the safety switch located in the handles is activated, the unit will automatically shut off for your safety. To reactivate the unit, put back the power head properly in position, and turn the cook time dial back to “OFF” first, then set it to the remaining cook time. Cooking will resume.

CLEANING AND CARE INSTRUCTIONS

GENERAL INSTRUCTIONS:

- Unplug the unit before cleaning.
- Dome and all other parts, except the power head are dishwasher safe. Protect the metal and plastic surfaces; do not use abrasive cleaners or scouring pads.
- Clean after each use.
- The outer surface of the power head can be cleaned by wiping it with a damp cloth.



IMPORTANT TIPS:

1. Check the power outlet for proper operation. Do not operate the unit with other major appliances in the same power outlet. Check power level if the unit cooks too slowly.
2. Check to see if electrical plug is properly plugged into the outlet.
3. Always turn off and unplug the unit before washing.
4. Moisture may build up inside the dome when cooked food is not removed soon after cook time has expired. The steam/moisture build up can be avoided by doing the following:
 - Remove food soon after it is done cooking.
 - If it is desirable to keep the food warm until served, reset cooking time at low power (1 or 2).

THE MANUFACTURER WARRANTIES:

The infrared cooking system including power head, dome, cooking rack, liner pan, base, and all electrical components to be free from defects and workmanship under normal household use, when operated in accordance with the Manufacturer's written instructions provided with each unit for **one (1)** year from date of purchase. The Manufacturer will provide the necessary parts and labor to repair any part of the infrared cooking system at Hearthware Home Products Service Department. After the expiration of the warranty, the cost of the labor and parts will be the responsibility of the owner.

THE WARRANTY DOES NOT COVER:

The non-stick coating (if applicable) on any part of the cooking system. The Limited Warranty is voided if repairs are made by an unauthorized dealer or the serial number data plate is removed or defaced. Normal deterioration of finish due to use or exposure is not covered by this Warranty. This Limited Warranty does not cover failure, damages or inadequate performance due to accident, acts of God (such as lightning), fluctuations in electric power, alterations, abuse, misuse, misapplications, corrosive type atmospheres, improper installation, failure to operate in accordance with the Manufacturer's written instructions, abnormal use or commercial use.

TO OBTAIN SERVICE:

The owner shall have the obligation and responsibility to: Pay for all services and parts not covered by the warranty; Prepay the freight to and from Service Department for any part or system returned under this warranty; Carefully package the product using adequate padding material to prevent damage in transit. The original container is ideal for this purpose. Include in the package owner's name, address, daytime telephone number, a detailed description of the problem, and your **RETURN GOODS AUTHORIZATION NUMBER (RGA number)**. Call **1-888-NUWAVE1(689-2831)** or e-mail customerservice@hearthware.com to obtain the RGA number. Provide the cooking system **model & serial number** and **proof of date of purchase** (a copy of the receipt) when making claims under this warranty.

MANUFACTURER'S OBLIGATION:

The Manufacturer's obligation under this Limited Warranty is limited to repairing or replacing any part of the infrared cooking system expressly covered by this Limited Warranty which upon examination is found to be defective under normal use. The Limited Warranty is applicable only within the continental United States and only to the original purchaser of manufacturer's authorized channels of distribution. The limited warranty may not be altered, varied or extended except by written instrument executed by the manufacturer. The remedy of repair or replacement as provided under this limited warranty is exclusive. In no event shall the manufacturer be liable for any consequential or incidental damages to any person, whether or not occasioned by negligence of the manufacturer, including without limitation, damages for loss of use, costs of substitution, property damage, or other money loss.

Some states do not allow the exclusion or limitation of incidental or consequential damages, so the above limitation exclusions may not apply. This Limited Warranty gives specific legal rights, and there may also be other rights which vary from state to state. Except as otherwise expressly provided above, the manufacturer makes no warranties expressed or implied arising by law or otherwise, including without limitation, the implied warranties of merchantability and fitness for a particular purpose to any other person.

READ YOUR OWNER'S MANUAL: If you still have any questions about operation or warranty of the product, please contact Hearthware Home Products at **1-888-NUWAVE1(689-2831)** or e-mail customerservice@hearthware.com



At **Hearthware Home Products**, we have taken a great amount of care in ensuring that our products are safe and secure for every household. All Nuwave® Pro Infrared Ovens are built and manufactured in strictest compliance with RoHS* standards.

Although US manufacturers are not bound by law to follow RoHS standards, Hearthware has made a conscious decision to voluntarily follow this directive to preserve the safety of its consumers and the environment.

RoHS Restricted Materials

Material & Toxicological Profile	Maximum Concentration
Lead (Pb)	0.1% by weight
Mercury (Hg)	0.1% by weight
Cadmium (Cd)	0.01% by weight
Hexavalent Chromium (Cr-VI)	0.1% by weight
Polybrominated Biphenyls (PBB)	0.1% by weight
Polybrominated Diphenyl Ethers (PBDE)	0.1% by weight

*RoHS stands for "the Restriction of the use of certain Hazardous Substances in electrical and electronic equipment".

If you want to find out more about the RoHS Directive, please visit <http://en.wikipedia.org/wiki/RoHS>



FROZEN, FRESH, THIN OR THICK...
We love baking pizza in the NuWave Oven so much, we've created these tools to be used with your NuWave Oven so you can bake the best tasting pizza ever! Achieve "hot, fresh, better than just delivered pizza" at home... **AS EASY AS 1 - 2 - 3** when you use your NuWave Oven with the NuWave Pizza Accessories! Whether you prefer your pizza thin, regular or even deep dish thick...your NuWave Oven, along with these NuWave Pizza Accessories will do the trick!

The NuWave Supreme Pizza Kit*

The NuWave Stainless Steel Pizza Flipper The spring-loaded, easy grip handle allows you to securely clamp the 10" stainless steel rings shut, safely letting you flip your pizzas, calzones, quesadillas and Much More!

The NuWave Silicone Pizza Liner Allows you to bake your pizza crust first without overcooking your cheese or favorite toppings. The slick surface will not stick to the cheese, but will attract unwanted grease. (Complies with FDA Regulations)

The NuWave Stainless Steel Pizza Server Two great utensils rolled into one! The NuWave Pizza Server with the multiple stainless steel cutting surfaces and easy grip handle will have you slicing and serving your pizza with ease.

The NuWave 100% Bamboo Cutting Board The unique bamboo cutting board will save your counter tops, save you money and help save the environment. Also, this board is multi-functional with a flat side for cutting pizzas and breads and a grooved side for using with foods with juices.

*Your order may contain only some of the above items. To purchase this product, call our Customer Service at 1-888-689-2831 or order online at www.nuwaveoven.net



HOW TO PROPERLY USE THE NUWAVE PIZZA FLIPPER AND PIZZA LINER IN YOUR NUWAVE OVEN

NOTE: Make sure the reversible rack is positioned as the 4" rack in the NuWave Oven.

1. Place the Pizza Liner over the top of your pizza.
2. Place pizza upside down on the 4" rack. Cook on power level HI, until crust of pizza is a light brown in color.



3. When using Pizza Flipper, start with Pizza Flipper open and slide the flipper under the Pizza Liner and over the top of the crust.



4. Using the handle, close the Pizza Flipper until pizza is able to be held firm.

5. While gripping the handle, rotate the pizza and Pizza Liner completely around and set pizza back on the rack crust side down.

The pizza should now be right side up.



6. Remove the Pizza Liner and cook on power level HI for 3-5 minutes or until cheese is melted to your desire.

The NuWave Complete Supreme Pizza Kit:



The NuWave Stainless Steel Pizza Flipper

The NuWave Silicone Pizza Liner

The NuWave Stainless Steel Pizza Server

The NuWave 100% Bamboo Cutting Board



TO SLICE AND SERVE WITH THE NUWAVE STAINLESS STEEL PIZZA SERVER.

NOTE: The edges of the spatula and pizza cutter can be sharp. Always cut away from you

CAUTION: serrated edges can be sharp, do not use serrated edge for support.

Rolling Slicer:

Hold handle so the Pizza Server is on the top and you are able to cut with the Pizza Cutter.



Serrated Slicer:

Both the Pizza Cutter and the Pizza Server can be used to slice foods such as pizzas, quesadillas, panini sandwiches, quiche and much more. Slice in a back-n-forth motion to slice foods.



Server:

To use the Pizza Server, simply have the edge of the spatula pointed away from you and with a scooping motion lift the pizza or food out and place on a serving dish.



CARE & USE:

For the Pizza Flipper, Pizza Liner, Pizza Server and Bamboo Cutting board, wash with mild soap and water. It should not be cleaned with any harsh abrasive. Before using or storing, utensils must be completely dry.



Perfect Pizza Every Time!
Pizza baked in the NuWave Oven comes out perfect every time, so the only thing left to do is ENJOY!



	Rack Height	Fresh Time	Frozen Time	Internal Meat Temperature (by thermometer) / Notes:
Beef / Lamb:				
Patties (½" thick)	4 inch	4-5 min/side	6-7 min/side	150°F (65°C)
Patties (1" thick)	4 inch	6 min/side	11 min/side	150°F (65°C)
Steaks (1" thick)	4 inch	5-6 min/side 6-7 min/side 7-8 min/side 9-10 min/side	11 min/side 13 min/side 14 min/side 18 min/side	Rare 135°-140°F (60°C) Med. Rare 140°-150°F (66°C) Medium 150°-160°F (71°C) Well-Done 160°-170°F (77°C)
Steaks (2" thick)	4 inch	7 min/side 9 min/side 10 min/side 12 min/side	15-17 min/side 17-19 min/side 20-22 min/side 23-25 min/side	Rare 135°-140°F (60°C) Med. Rare 140°-150°F (66°C) Medium 150°-160°F (71°C) Well-Done 160°-170°F (77°C)
Roasts 3-5 lbs (Let rest 10 minutes before serving)	1 inch	15 min/lb. 18 min/lb. 20 min/lb. 23 min/lb.	25 min/lb. 28 min/lb. 30 min/lb. 33 min/lb.	Rare 120°-129°F (54°C) Med. Rare 130°-139°F (60°C) Medium 140°-149°F (65°C) Well-Done 150°-159°F (71°C)
Pork:				
Bacon	4 inch	8 minutes	For Extra Crispy, flip & cook an additional 2 minutes.	
Ham	1 inch	15 min/lb.	Apply glaze before last 5 minutes of the cooking time.	
Sausage Links	4 inch	4 min/side	5 min/side	
Patties	4 inch	5 min/side	7 min/side	165°F (74°C)
Italian, Bratwurst	4 inch	5 min/side	8 min/side	165°F (74°C)
Chops	4 inch	5 min/side	10-12 min/side	160°-170°F (71°-77°C)
Roasts 3-7 lbs	1 inch	20-25 min/lb.	30 min/lb.	160°-170°F (71°-77°C)
Tenderloins, small	4 inch	10-12 min/side	20 min/side	160°-170°F (71°-77°C)
Spare Ribs	Either	15 min/side	25 min/side	160°-170°F (71°-77°C)
Country Style Ribs	4 inch	13 min/side	20 min/side	160°-170°F (71°-77°C)
Hot Dogs	4 inch	6 min/side	10 min/side	150°F (65°C)
Chicken:				
Pieces: Breasts, Legs, Thighs	4 inch	10 min/side	13 min/side	170°F (76°C)
Whole	1 inch	15 min/lb.	23-25 min/lb.	180°F (82°C)
Breasts ½ inch thick Boneless/Skinless	4 inch	7-8 min/side	10 min/side	170°F (76°C)
Eggs:				
Boiled	1 inch	8-11 min.	Cook time based on doneness, let cool, rinse with cool water, peel, serve.	
Turkey:				
Whole (8-10 lb.)	1 inch	15-17 min/lb.	20-22 min/lb.	180°F (82°C)
Breasts (5-7 lb.)	1 inch	12 min/lb.	15 min/lb.	180°F (82°C)
Legs	1 inch	23 min/side	30 min/side	180°F (82°C)
Wings	1 inch	15 min/side	23 min/side	180°F (82°C)
Poultry:				
Cornish Hen Whole (1-1 ½ lb.)	1 inch	15-20 min/lb.	30-35 min/lb.	170°-180°F (77°-82°C)
Duck Whole (5-6 lb.)	1 inch	12 min/lb.	24 min/lb.	170°-180°F (77°-82°C)





	Rack Height	Fresh Time	Frozen Time	Internal Meat Temperature (by thermometer) / Notes:
Seafood:				
Fish: Fillets (½" thick)	4 inch	3-4 min/side	5-7 min/side	150°F (65°C)
Fish: Steaks and Fillets (1" thick)	4 inch	4-5 min/side	7-9 min/side	150°F (65°C)
Whole Fish (3-4" thick)	4 inch	15 min/side	25 min/side	150°F (65°C)
Shrimp (Medium 2½ size)	4 inch	3-4 min/side	4-6 min/side	Cooking time may vary with size.
Scallops, Sea	4 inch	4 min/side	5 min/side	Scallops and/or Lobster turn opaque when cooking is complete.
Scallops, Bay	4 inch	3 min/side	3-4 min/side	
Lobster Tails 4oz.	4 inch	4 min/side	6 min/side	Bring large pot of water to a boil. Drop in lobsters head first. Cook for 2 minutes before placing in NuWave Oven.
Lobster, Live Maine	4 inch	13-16 min/lb.		
Vegetables / Fruits:				
Corn on the Cob	Either	7-8 min/side	Alternative, season to taste and wrap in foil. Cut into 2 inch cubes. spray with oil.	
Root Vegetables	Either	20-30 min.		
Potatoes: Whole ½ Lengthwise	Either	45-47 min. 30 min.	8 ounces each	
French Fries	Either	20 min.		
Roasted Onions	4 inch	20 min.	Cut ½ inch top, brush with oil.	
Roasted Garlic	4 inch	25 min.		
Steamed Broccoli	4 inch	5-8 min.	Varies with thickness.	
Squash	Either	30-35 min.	Cut in half, remove seeds and membrane, place in shallow dish, brush with oil.	
Eggplant Whole	Either	30 min.		
Eggplant (½" slices)	4 inch	12-15 min.		
Baked Apples	Either	18-20 min.	Remove core. Cut in half, remove core.	
Baked Pears	Either	20-25 min.		
Pizza / Quesadillas:				
		Frozen		
Thin Crust	4 inch	15-18 min. (+)		
Regular Crust	4 inch	18-20 min. (+)		
Thick Crust	4 inch	20-25 min. (+)		
Quesadilla	4 inch	4 min/side		
<ol style="list-style-type: none"> 1) Place pizza, cheese side down on NuWave Pizza Liner. 2) Bake crust per time indicated to left or until desired doneness. 3) Flip pizza, cheese side up and remove NuWave Pizza Liner. 4) Bake pizza 3-5 more minutes or until desired doneness. 				



GENERAL TIPS

This recipe book contains valuable information to help you get started incorporating the NuWave® Pro Infrared Oven into your daily life. We've provided easy-to-prepare recipes, along with helpful tips at the beginning of each section for perfect results every time. Look for the following icons next to recipes for additional tips, heart healthy recipes and/or recipes that save even more time.

 Additional time-saving tips.

 Heart healthy recipes.

 Tips for using your NuWave Infrared Oven.

 Our executive chef's own favorite recipes.

Metal containers, aluminum foil and any oven-safe dish can be used in the NuWave® Pro Infrared Oven. The infrared rays will not penetrate through the metal.

Nuwave[®]
PRO INFRARED OVEN

Dark metal pans will produce the best browning results with baked goods such as cookies and rolls.

Lightweight aluminum foil works the best with shallow dishes and pans.

Cover food with aluminum foil to protect food from browning. Heat will still circulate, but it may slow the cooking time of the food beneath it.

Steam can build up when you cook foods that contain a lot of moisture, like vegetables or fish. Please remember to always lift the dome away from you so the steam is channeled away from your face.

To keep foods crisp, like egg rolls, chicken tenders or pizza, remove the dome immediately after cooking.

The key to perfection with the NuWave Oven is timing. When a food is not completely cooked, remember the cook time can be up to half the time of a regular oven so a "quick 10 minutes" can cook an Italian sausage. When cooking larger foods such as a roast, if it is not cooked to perfection, (due to the thickness of the food) either cook in 3-4 minute increments or simply slice into medallion slices and cook for about 2-3 minute increments.

TIPS FOR BREAKFAST

Bacon: Cook for 8-9 minutes on a 4" rack. For extra crispy bacon, flip and cook for an additional 2 minutes. Sprinkle on brown sugar for a sweet taste. For easy clean-up, place aluminum foil on the liner pan. Once the grease solidifies, discard the aluminum foil.

Hard boiled eggs, no boiling water required: Place eggs on the 1" rack and cook on Power Level 9 for 10 minutes. Remove the eggs promptly, letting them cool completely for about 5 minutes. Run under cold water or place in a bowl of cold water for easy shell removal.

Egg substitutes can be used in any recipe in place of raw eggs.

Warm pre-made muffins, breads or pastries: Simply wrap them in aluminum foil and place on the liner pan during the last 2 minutes of cooking time.

Place bagels, English muffins or bread on the 4" rack and cook on HI for about 4 minutes.

Quick Reference for Everyday Breakfast Foods

Breakfast sausage links:
8 minutes on 4" rack.

Breakfast sausage patties:
10 minutes on 4" rack.

Eggs, scrambled:
7-10 minutes on 4" rack
Place in well greased dish,
stir halfway.

Eggs, sunny-side :
7 minutes on 1" rack in small, Teflon,
buttered pan or 7 minutes on 4" rack
in large greased custard cup.

Nuwave[®]
PRO INFRARED OVEN

Ham and Cheese Strata 🍳

- I make this every Christmas morning. You can make this ahead and let it sit covered in your refrigerator, the day ahead. Pop in the NuWave and you have a great hot meal any time.

- 10 slices of bread
(white or wheat your choice)
- 1½ cups cubed ham
- 6 ounces shredded Swiss cheese
- 6 ounces shredded Cheddar cheese
- 4 large eggs
- ½ teaspoon salt
- 1 teaspoon onion powder
- 1½ cups milk
- 1 teaspoon dry mustard
- ¼ teaspoon red pepper
- 1½ cups corn flakes
- 4 tablespoons butter, melted

Trim crust from the bread and layer the 10" baking pan or an 8" x 8" pan that has been greased (you can press the bread to make it fit. If you have extra that's okay). Layer ham and cheeses, alternating at least once. Mix eggs, milk and seasonings together and pour over layers. Let it soak in. Mix corn flakes and melted butter and sprinkle on top. Bake on the 1" rack for 40 minutes on power level HI. If it starts to brown, cover the top with foil, loosely. When the timer goes off, let it sit for 1 to 2 minutes. Check doneness with a toothpick.

Joe's Special Scramble ♥

- 2 large eggs
- ½ cup frozen spinach prepared as directed on the package
- ½ cup cottage cheese
- 3 ounces ground beef, crumbled and NuWave 5 to 6 minutes
- salt & pepper to taste

Mix everything in a shallow dish and place on the 4" rack. Cook on power level HI for 10 minutes or until the eggs are set. Stir and serve.

(1 serving)

Ham and Eggs Scramble ♥

- 2 large eggs
- 3 ounces ham, chopped
- 2 tablespoons parsley, chopped
- 2 ounces shredded Cheddar cheese
- salt & pepper to taste

Mix everything in a shallow dish and place on the 4" rack. Cook on power level HI for about 7 minutes, stir and serve.

Tips: For a spicy kick, add 3 ounces of crumbled chorizo sausage.
(1 serving)

Scrambled Lox ♥

- 2 large eggs
- 2 ounces lox
- 2 tablespoons cream cheese
- 1 scallion, thinly sliced
- 1 tablespoon capers
- ½ cup shredded Swiss cheese
- salt & pepper to taste

Mix everything in a shallow dish and place on the 1" rack. Cook on power level HI for about 8 minutes or until the eggs are barely set. Stir and serve.

(1 serving)

Chorizo Sausage and Eggs

- 2 large eggs
- 3 ounces chorizo sausage
- 2 tablespoons salsa
- 2 ounces shredded Monterey Jack cheese
- hot sauce to taste

Press the sausage around the edge of a saucer. Crack the eggs in the center and top with the salsa and cheese. Place on the 1" rack and cook on power level HI for 10 minutes or until the eggs are set.

(1 serving)

Steak and Eggs 🍳💡

- 1 (4 ounce or ½" thick) sirloin steak
- seasoned salt
- 2 large eggs
- 1 scallion, thinly sliced
- ½ tomato, seeds removed
- 2 tablespoons grated Parmesan cheese

Crack the eggs in a shallow dish and place on the liner pan. Place the steak and tomato on the 4" rack to the side of the eggs. Season the steak and add the cheese to the tomatoes. Cook on power level HI for 10 minutes.

Tips: To prepare from frozen, place the frozen steak on the 4" rack and cook on HI for 8 minutes, add the eggs and tomato and cook another 10 minutes.
(1 serving)

NuWave Muffin Sandwich

- 2 large eggs
- 2 English muffins, split
- 2 slices Canadian bacon
- 2 slices American cheese
- salt & pepper to taste

Spray two large custard cups with oil. Crack one egg into each cup. Gently break yolk. Salt & pepper with desired amount. Place the four English muffin halves on the liner pan and place the eggs on the 4" rack. Cook on power level HI for about 7 minutes. When timer goes off place the slices of Canadian bacon on the rack next to the eggs. Finally, place cheese on top of muffins and cook for an additional 2 minutes. Assemble together & enjoy!

Tips: Replace Canadian bacon with frozen breakfast sausage patties. Consult your Quick & Easy Cooking Guide for correct cooking time.
(2 servings)

Oven Omelette 🍳

- Use the 10" baking pan, or if you don't have one use a 9" square pan. This is a quick and easy dish. Enjoy!

- 10 eggs, beaten
- ½ cup milk
- 6 ounces shredded Cheddar cheese
- 1 cup ham or bacon, finely chopped (can use sausage, cook and drain grease)
- ½ cup green pepper, chopped
- ¼ cup onion, chopped
- 1 tablespoon parsley

In a medium bowl, beat the eggs and milk until fluffy. Stir in the cheese, meat, green pepper, and onion. Pour into the greased pan. Bake on the 1" rack and cook on power level HI for 12 to 15 minutes. Let sit with the dome on for 1 minute and then cut into desired sizes. In the round pan, cut the omelette in a pie shape.

Broiled Grapefruit

- 2 grapefruits, cut in half and sectioned with a knife, leaving sections undisturbed
- 1 teaspoon pure vanilla extract
- 2 tablespoons light brown sugar

Divide the vanilla between the centers of the grapefruit. Sprinkle brown sugar on top of each half. Place on foil on 4" rack. Cook on power level HI for 8 to 10 minutes.
(2 servings)



Breakfast Casserole 🍳

- Fuel up for the day with this thyme – flavored ham and potato casserole. Change it up by adding another fresh herb such as basil, oregano, or tarragon.

- 1 lb. tiny new potatoes cut into ¼" slices
- ⅓ cup thinly sliced leek
- ¾ cup lower-fat and lower-sodium cooked ham, chopped
- 3 ounces reduced-fat Swiss cheese, cut into small pieces
- 1¼ cups fat-free milk
- 1 tablespoon all purpose flour
- ¾ cup refrigerated or frozen egg product, thawed
- 2 teaspoons snipped thyme or ½ teaspoon dried thyme, crushed
- ¼ teaspoon black pepper

In a covered large saucepan cook the sliced potatoes in a small amount of boiling lightly salted water about 10 minutes or until tender. Add the leeks during the last 5 minutes. Drain the potato mixture. Coat a 2 quart rectangular baking dish with cooking spray. Place potato mixture in the bottom of the prepared baking dish. Sprinkle with the ham and Swiss cheese. In a medium bowl, stir the milk into the flour until smooth. Stir in the egg product, thyme and pepper. Pour egg mixture over potato mixture. Bake on the 4" rack on power level HI for 15 to 17 minutes or until a knife inserted near the center comes out clean. Serve immediately.

Nutrition facts per serving:

180 calories, 4g total fat, 1g saturated fat, 16mg cholesterol, 445mg sodium, 23g carbohydrates, 1g dietary fiber, 13 protein.

Cinnamon Breakfast Twists 💡

- 1 package refrigerated breadsticks
- ½ cup butter, melted
- 1 cup sugar
- 2 teaspoons cinnamon

Mix the sugar and cinnamon in a medium bowl. Set aside. Pour melted butter into a pie plate. Dredge breadsticks in butter one at a time and then place in sugar mixture one at a time. Toss to coat. Hold breadstick by each end and twist. Set on 4" rack and bake on power level HI for 11 minutes, turning once; this will make the twists nice and crisp. Bake for 9 minutes if a softer twist is desired.

(4 servings)

Tips: Brush a beaten egg on breadstick and sprinkle with sesame seeds, poppy seeds, or grated cheese.



Low-Cal French Toast ♥

Soak favorite bread in egg substitute and roll in corn flake crumbs. Place bread on 4" rack and bake on power level HI for 10 to 15 minutes, turning halfway. If you want to make enough for a large family, start one batch on the liner pan. When those are ready to be turned, place the 4" rack in place and continue as above. Top with low-calorie syrup or fruit and you have a crispy, healthy, and delicious breakfast!

Brown Sugar French Toast

- ¼ cup butter
- ½ cup packed brown sugar
- 1 tablespoon corn syrup
- round loaf of bread (about 8 to 9")
- 3 large eggs
- ¾ cup half-and-half
- 1 teaspoon vanilla
- ¼ teaspoon salt

Melt butter with brown sugar and corn syrup in a small saucepan over moderate heat. Stir until smooth. Pour into an 8" X 8" glass-baking dish or a 9" pie plate that has been sprayed with oil. Trim crust and cut bread into 1" slices. Arrange bread slices in one layer in a baking dish. In a medium bowl, whisk together eggs, half-and-half, vanilla, and salt. Pour evenly over bread. Cover and refrigerate at least 30 minutes. Place baking dish on 1" rack. NuWave on power level HI for 30 minutes.

(2 servings)



Banana Bread 🍌

- Throw this together with the bananas that are turning on you. I make and freeze, so this way I always have something in my freezer if someone stops by. I slice the frozen bread and heat slices for 1 to 2 minutes depending on the size of your slice.

- 3-4 Bananas (depending on their size; slightly mushy)
- 2 cups sifted all purpose flour
- ¾ teaspoon salt
- 1½ teaspoons baking soda
- 1½ cups sugar
- ¾ cup shortening
- 3 large eggs

Measure and sift the flour (sifting the flour is very important as it helps lighten up the bread). Add baking soda and salt to the flour. Mix well. Set dry ingredients aside. Cream shortening and gradually add sugar until light and fluffy. Add eggs, one at a time, beating after each addition. Mash bananas with a potato masher, then add bananas to the creamed mixture and blend. Add dry ingredients all at once. Stir enough to moisten the flour. Bake in a loaf pan that has been oiled and floured. Bake on the 1" rack for 45 minutes on power level HI. Check bread at 40 minutes by hitting the PAUSE button. If bread is getting too brown, cover with foil and resume baking. Let the bread sit for 1 to 2 minutes before taking off the dome. Check with a toothpick, if it comes out clean your bread is done.



TIPS FOR APPETIZERS

Prepared foods from your grocery's freezer section make great easy snacks for appetizers or entertaining, and these items are prepared to perfection in about 8 minutes per side, with no defrosting required. Some of the most popular choices include:

- Hot wings
- Corn dogs
- Bagel bites
- Chicken tenders
- Poppers
- Potato skins
- Egg rolls
- Pot stickers
- French fries

For the best grilled cheese sandwich, use the 4" rack and cook on HI for 3 to 4 minutes per side. Add some ham or turkey for extra protein!



Baked Party Sweet Onion Dip

- This is the easiest recipe. It takes after the artichoke dip. You can substitute a low-fat cheese and mayonnaise. Sweet onions work the best and are available year round.

- 2 large onions, chopped medium dice
- 2 cups Parmesan cheese
- 2 cups low-fat mayonnaise
- ½ teaspoon black pepper

Mix all ingredients in your 10" baking pan. Smooth the ingredients flat and place on the 1" rack. On power level HI, cook for 15 minutes or until it turns brown and bubbly. Serve with your favorite cracker or bread.

Rumaki

- 6 slices bacon
- 24 small shrimp or 12 jumbo shrimp cut in half
- ¼ cup sliced water chestnuts

Cut the bacon into 4 equal pieces and lay on a piece of shrimp and a slice of chestnut. Roll and secure with a toothpick. Place on the 4" rack and cook on power level HI for 8 minutes.

Tips: Replace shrimp with tofu, chicken livers or mussels.

Baked Brie

- This is a creamy spread that can be served at almost any time, for brunch, as an appetizer or for a dessert. Let your imagination run wild for the toppings. Try hot pepper jelly, mango salsa, cranberry pear relish, or your other favorite jams or jellies. Serve with crackers, breads, fruit or raw vegetables. Use our 10" baking pan or any oven safe dish.

- 1-7 ounces round of Brie cheese
- ⅓ cup peach or apricot jam
- ⅓ cup cranberry sauce
- 2 tablespoons toasted almonds

Place brie on the 12" liner pan. In a bowl, combine peach jam, cranberry sauce and nuts. Spoon over the brie. Bake on the 1" rack on power level HI for 4 to 5 minutes (cooking depends how thick the rind on the brie is). Let rest for 5 minutes and serve with your favorite crackers or bread.

(4-8 servings)

Topping Suggestions:

Pecan and Brown Sugar

In a small bowl, combine ½ cup of packed brown sugar and ¼ cup chopped pecans. Spoon over brie and bake for 4 to 5 minutes on power level HI. Let rest for 5 minutes and serve with your favorite crackers or bread.

Fig and Port Topping

In a medium saucepan, combine 1 cup chopped dried figs with ½ cup orange juice and ½ cup port. Bring to a boil for 4 minutes. Spoon over brie and bake for 4 to 5 minutes on power level HI.

Strawberry Salsa Topping

In a medium bowl, combine 1 cup coarsely chopped fresh strawberries, 1 chopped green onion, 2 teaspoons chopped jalapeno pepper, 1 tablespoon olive oil and 1 tablespoon orange juice. Bake brie for 4 to 5 minutes on power level HI and spoon over before serving.

Stuffed Italian Sausage Mushrooms

- This recipe is done in the 12" liner pan and finished on the 4" rack. I make these a day ahead if I'm having people over. They freeze great! Either way they turn out beautiful.

- 24 medium or 12 large Button mushrooms or your favorite type; washed and cleaned with a mushroom brush, stems removed
- 1 lb. bulk Italian sausage
- 1 small onion, chopped
- 2 stalks celery, chopped
- 2 cloves garlic, chopped
- 1 cup Mozzarella cheese
- salt & pepper to taste

Brown the sausage in the 12" liner pan for 7 minutes on power level HI. Drain the fat. Place the sausage back in the liner pan. Add all vegetables to the drained sausage and continue to cook on power level HI for 5 minutes. Let cool for 5 minutes and add the cheese. Stuff the mushrooms with the sausage mixture and place on the 4" rack for 3 minutes for medium size mushrooms, or 5 minutes for large mushrooms on power level HI. If the mushrooms are frozen, cook on power level HI for 8 to 10 minutes.



Chicken Kabobs with Peanut Sauce 🍴

- Make this marinade before you go to work or start your day. Come home and place kabobs on the NuWave for a delicious meal!

- 4 boneless, skinless chicken breast halves (about 1½ lbs)
- ¼ cup soy sauce
- 1 tablespoon vegetable oil
- 1 teaspoon packed brown sugar
- ¼ teaspoon ground ginger
- 1 clove

Cut the chicken into ¾" pieces (for ease in cutting, partially freeze chicken). Mix the chicken, soy sauce, vegetable oil, brown sugar, ginger, and garlic in a medium plastic or glass bowl. Cover and refrigerate at least 2 hours.

Peanut Sauce:

- 1 small onion, finely chopped
- 1 tablespoon vegetable oil
- ½ cup peanut butter
- ½ cup water
- 1 tablespoon lemon juice
- ¼ teaspoon ground coriander
- 3-4 dashes red pepper sauce

Remove the chicken from the marinade and reserve the marinade. Thread four to five chicken pieces on each of fourteen to sixteen 6" or 8" metal skewers. Brush with chicken marinade. In batches, place the kabobs on the 4" rack and cook for 4 to 5 minutes per side, or until juices run clear. Place on a serving tray with peanut sauce in the middle of the tray. Enjoy!



Baked Reuben Sandwich

- 2-4 tablespoons butter, softened
- 2 slices rye bread
- 2 ounces thinly sliced corned beef
- ¼ cup sauerkraut, squeezed dry
- 1 slice Swiss or Gruyere cheese
- 1 tablespoon Thousand Island dressing

Lightly butter one side of each slice of bread. On the unbuttered side, place corned beef, sauerkraut, and cheese. Spread with dressing. Top with second slice of bread, buttered side up. Cook on power level HI for 4 minutes. Flip sandwich and cook an additional 4 minutes on power level HI.

(1 serving)

Ham and Cheese Pitas

- 4 pita bread rounds (8")
- 4 thin slices of ham, cut in half
- 4 slices sharp Cheddar or Swiss cheese, cut in half
- 1 red onion, very thinly sliced
- 2 ripe tomatoes, very thinly sliced
- 1 tablespoon melted butter
- paprika for color

Cut the pita rounds across the center, making 8 half circles. Stuff each half with the ham, cheese, onions, and tomato. Using a pastry brush, lightly butter the outside of each pita sandwich and sprinkle with paprika. Place directly on the 4" rack and cook on power level HI until outside is brown and the cheese has melted for about 3 to 5 minutes.

(4 servings)

Buffalo Chicken Wings

- 1 jar buffalo hot sauce
- ¼ cup butter, melted
- 2 dozen split chicken wings

Combine hot sauce and butter and marinate wings at least 2 hours. Place wings on the 4" rack and cook on power level HI for 20 to 25 minutes, turning halfway.

(20 pieces)

Water Chestnuts Wrapped in Bacon

- ¼ cup soy sauce
- ⅓ cup honey
- 1 tablespoon oil
- 1 tablespoon ketchup
- ½ teaspoon garlic powder
- 1 (5 ounce) can of whole water chestnuts
- about 10 strips of bacon

In a small bowl mix the first five ingredients. Set aside. Drain the water chestnuts and set them on a couple of paper towels for absorption. Cut each strip of bacon into three pieces. Wrap a piece of bacon around a water chestnut and secure with a toothpick. Place in a glass baking dish. Repeat until all of the water chestnuts are used. Pour soy sauce mixture on top and allow to marinate for 20 minutes. Place water chestnuts on the 4" rack. Bake on power level HI for 4 minutes. Turn water chestnuts and bake for an additional 4 to 5 minutes.

(20 pieces)

Chinese Style Ribs 🍷

- 1 cup soy sauce
- 3 tablespoons dry red wine
- 1 tablespoon each sugar, salt, & garlic powder
- 2 lbs. baby back ribs, cut into individual pieces

Mix all the ingredients and marinate the ribs for at least an hour. Spread the ribs on the 4" rack and cook on power level HI for 20 minutes, turning if needed.

(20 pieces)

Tips: Use equal parts pineapple juice and soy sauce. Marinate well and then roll in seasoned bread crumbs.

Jumbo Lump Crab Cakes 🍴

- This recipe makes four large cakes or eight medium size cakes. If you want to make small cakes for appetizers, form smaller cakes.

- 16 ounces jumbo lump crab meat
- ⅔ cup fresh white or canned bread crumbs
- 2 teaspoons dijon mustard
- 2 tablespoons mayonnaise
- 2 tablespoons chopped chives
- 2 tablespoons chopped parsley
- 1 tablespoon lemon juice
- ½ teaspoon cayenne pepper
- 1 teaspoon Old Bay® seasoning
- salt & pepper to taste

Mix all ingredients other than the crab meat. Gently fold in the crab meat, leaving the meat in chunks. If your mix seems a little wet add more bread crumbs. If you like spicier food, add more cayenne. Form into desired crab cake sizes. Place on the 4" rack and cook on power level HI for 7 to 8 minutes. No need to turn.

Tips: Place over gourmet greens, or with your favorite sauce.

Remoulaude Sauce:

- 2 tablespoons pickle relish
- ¼ cup ketchup
- ½ cup mayonnaise
- 1 tablespoon lemon juice

Mix all ingredients and serve chilled.

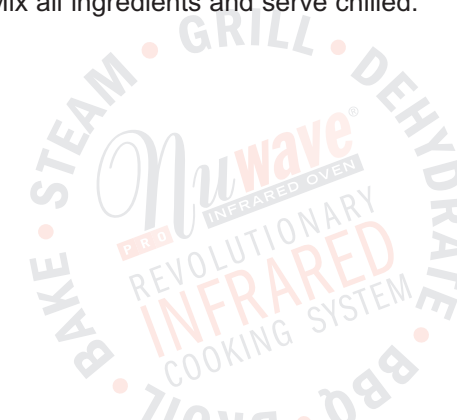

Crab Melt 🍷

- 2 cups cooked crab meat (tuna or shrimp)
- ¼ cup mayonnaise
- ½ cup diced celery
- ¼ cup chopped green onions
- 1 teaspoon lemon juice
- 4 slices firm white bread, lightly toasted
- ½ cup grated Monterey Jack cheese
- salt & pepper to taste

Mix crab, mayonnaise, celery, green onion, and lemon juice. Add salt and pepper to taste. Divide the mixture among the toast slices. Top each with grated cheese. Place directly on the 4" rack and cook on power level HI for 4 minutes or until well heated and cheese melts.

(4 servings)

Sesame Cheese Pillows

- 1 package refrigerated breadsticks
- 8 Swiss cheese slices
- 1 egg, beaten
- 4 tablespoons sesame seeds

Separate breadsticks. On a floured surface, press breadsticks to make one (¼" x 8") sheet. You may have to dip your fingers into flour to prevent them from sticking to the breadstick dough. Cut cheese into strips that will fit on top of breadstick, leaving about ⅛" around the perimeter. Layer the breadstick and cheese as you would a sandwich. Cut into eight equal pieces. Crimp edges with the tines of a fork. Brush each pillow with beaten egg. Sprinkle sesame seeds on top. Continue until all of the breadsticks are used. Carefully place each pillow on the baking pan. Set on the 4" rack and cook on power level HI for 8 minutes.

Tips: Place in a piece of sliced Canadian bacon, or cooked meat such as sausage, chicken, shredded beef, etc. for a filling treat. (20 pieces)

Teriyaki Chicken

- 4 large chicken breasts cut lengthwise into 10½" strips
- 1 cup soy sauce
- 1 teaspoon garlic powder
- 1 tablespoon lemon pepper
- 2 tablespoons freshly grated ginger root

Mix everything and marinate for 30 minutes. Thread each strip on a skewer and place on the 4" rack. Cook on power level HI for about 8 minutes or until lightly browned and the chicken is cooked. (20 pieces)

Southern Style Shrimp with White Wine 🍷

- This whole recipe is done in and served in the 12" liner pan. I love to prepare this recipe when my friends are over. It's easy, tasty, and everyone loves the shrimp. Keep in mind this recipe can be used either for dinner or for an appetizer.

- 2 lbs. 21/15 shrimp (peeled and de-veined)
- 1 medium onion, chopped
- 1 teaspoon blackening spice
- 1 can chopped plum tomatoes (15.5 ounce, you can also use fresh)
- 1 tablespoon extra virgin olive oil
- 3 tablespoons garlic, chopped
- ½ cup dry white wine
- 2 tablespoons lemon juice
- ¼ cup chopped flat leaf parsley
- salt & pepper to taste

Place peeled and de-veined shrimp on the bottom liner pan. Add all other ingredients on top of the shrimp and gently mix. Place dome lid on and cook on power level HI for 10 minutes.

(6 servings for dinner or 12 servings for appetizer)



TIPS FOR PIZZA 💡

To cook a regular crust frozen pizza, place a piece of parchment paper or the NuWave Silicone Pizza Liner pan on the bottom, place the pizza UPSIDE DOWN on top of the NuWave Silicone Pizza Liner and then, cook according to directions. To finish, flip the pizza cheese side up and cook for an additional 3 to 5 minutes until the cheese melts.

Pizza Baking Recommendations

Thin Crust - Frozen

Estimated cooking time
15-18 minutes upside down
and 3-5 minutes right side up.

Regular Crust - Frozen

Estimated cooking time
18-20 minutes upside down
and 3-5 minutes right side up.

Thick Crust - Frozen

Estimated cooking time
20-25 minutes upside down
and 3-5 minutes right side up.

Deep Dish - Frozen

Estimated cooking time
35 minutes upside down and
about 10 minutes right side up.

Mexican Pizza

- 1 (8-9") flour tortilla
- 2 tablespoons tomato sauce
- ½ teaspoon taco seasoning or Mexican spice blend
- ⅓ cup fresh scallions, chopped
- ½ cup shredded Cheddar cheese
- sliced jalapeno peppers to taste

Place the tortilla on the 4" rack. Mix the sauce together with the Mexican spice blend and spread the top of the tortilla with the sauce. Arrange the jalapenos and scallions to taste over the sauce. Top with cheese. Cook on power level HI for 10 minutes.



Nuwave[®]
PRO INFRARED OVEN

Pita Pizza

- 1 (8-9") soft pita bread
- 2 tablespoons tomato sauce
- ¼ cup fresh chopped parsley
- 6-8 slices pepperoni
- ½ cup shredded Mozzarella cheese

Place the pita on 4" rack and spread the tomato sauce over the top. Top with parsley and pepperoni and then sprinkle cheese over the top. Cook on power level HI for 6 to 8 minutes.

(1 serving)

Goat Cheese Pizza

- 1 (8-10") pre-baked pizza crust
- 3 tablespoons tomato sauce
- 1 tablespoon fresh chopped basil
- 2 ounces crumbled goat cheese
- 2 ounces shredded 4 cheese Italian blend

Cook crust on 4" rack on power level HI for 3 minutes. Spread the top of the crust with the sauce and top with basil and cheeses. Cook on power level HI for 8 to 10 minutes.

(1-2 servings)

Meat Crust Pizza

- 4 ounces Italian sausage
- 4 tablespoons prepared pizza sauce
- 1 teaspoon dried Italian herbs
- 1 scallion, thinly sliced
- 1 large white mushroom, sliced
- 2 ounces shredded Mozzarella cheese
- 1 tablespoon grated Parmesan cheese

Press the sausage into a 6" disk on an oven safe dinner plate or pie plate. Spread on the sauce and spread the other ingredients over the sauce. Place on the 4" rack and cook on power level HI for 10 minutes.

(1 serving)

Cheesy French Bread 🍞

- This is fun for the kids to build their own cheesy bread. My kids liked just cheese, one liked pepperoni and broccoli. It's a great way for them to try new vegetables. I started putting different vegetables in the pizza sauce and blending. I felt better that they were getting some veggies. I have found if you give them many different choices they will always try. Good Luck.

- 1 shredded Cheddar or favorite cheese (8 ounce package)
- ½ cup mayonnaise or pizza sauce

Kid's favorite items to top their bread:

- ½ cup broccoli
- 1 cup ham, pepperoni, etc
- ¼ sliced black olives
- French loaf of bread cut in half.

Spread mayonnaise or pizza sauce on the bread. If you are using toppings, place on the bread. Top with cheese. Place bread on the 4" rack that has been sprayed with non-stick spray. Cook on power level HI for 5 to 6 minutes, or until cheese becomes bubbly and brown.

Pizza Boats 💡

- 4 (1" thick) slices of French bread
- ¾ cup pizza sauce
- ½ cup grated Parmesan cheese
- 4 slices Provolone or Mozzarella cheese to cover the bread
- one or more of the following:
 - sliced pepperoni, mushroom,
 - black olives, chopped bell peppers, etc.

Spray the bread with oil and spread on the sauce. Place on the 4" rack and toast on power level HI for 4 minutes. Add the cheese and other ingredients and place on the 1" rack. Cook on power level HI for about 8 minutes or until the cheese is melted and slightly browned.

Tips: Replace French bread with English muffins.

Mini Spinach Calzones 🍞

- Great to serve for an appetizer or for dinner. You can make these ahead of time to freeze and pull out when you need them. One of my favorite features is being able to cook from frozen on my Nuwave Oven.

- 5 ounce package frozen spinach (thawed and well-drained)
- 4 ounce package reduced-fat cream cheese (Neufchatel, softened)
- 2 tablespoons Parmesan cheese, grated
- 2 tablespoon green onion, chopped
- ¼ teaspoon ground black pepper
- 1 refrigerated pizza dough (13.8 ounce package)
- 1 egg white
- 1 tablespoon water
- 1 tablespoon grated Parmesan cheese

Spray the 4" rack with non-stick spray. For filling, stir together spinach, cream cheese, 2 tablespoons of Parmesan cheese, green onion, and pepper in a medium bowl. Set aside. Unroll pizza dough on a lightly floured surface. Roll the dough into a 15" square. Using a pizza cutter or sharp knife, cut into 25 (3") squares. Spoon a slightly rounded teaspoon of filling onto the center of each square. In a small bowl, whisk together the egg white and water. Lift a corner of each square and stretch dough over to the opposite corner, making a triangle. Press edges together with the tine of the fork. Arrange the calzones on prepared 4" rack. Prick tops of calzones with fork. Brush tops of the calzones with egg white mixture. Cook on power level HI for 10 minutes or until browned. For frozen, add 3 to 4 minutes or until browned and cooked in the middle.

Nutritional facts per appetizer:

56 calories, 2g total fat, 1g saturated fat, 4mg cholesterol, 125mg sodium, 8g carbohydrates, 2g protein.

(25 servings)

Calzones

- 1 tube of refrigerated pizza dough
- 1 cup shredded Mozzarella or Monterey Jack cheese
- ½ cup prepared spaghetti sauce
- ¾ lb. cooked Italian sausage, or pepperoni
- ¼ cup onions and tomatoes or any of your favorite vegetables

Roll out the dough so you can cut two, 6" disks from it. Spray the two 10" square sheets of foil with oil and lay the dough on the foil. Place equal amounts of the ingredients on each piece of dough and fold over to form half moon shaped packets. Wrap with the foil and place on the 1" rack. Cook on power level HI for 15 minutes or until crust is crisp and browned.

Italian Pizza Patties 🍞

- Make these pizza flavored patties, and watch the kids devour them! Serve them on buns for pizza-like cheeseburgers.

- 1 cup pizza sauce (divided)
- 1 egg, beaten
- ½ cup dry bread crumbs
- 2 teaspoons dried minced onion
- ½ teaspoon dried oregano
- ¼ teaspoon salt
- ⅛ teaspoon pepper
- 1½ lbs. ground beef
- 3 slices Mozzarella cheese (halved)

Spread mayonnaise or pizza sauce on the bread. If you are using toppings, place on the bread. Top with cheese. Place bread on the 4" rack that has been sprayed with non-stick spray. Cook on power level HI for 5 to 6 minutes, or until cheese becomes bubbly and brown.



TIPS FOR VEGETABLES

Place vegetables directly under the NuWave® Pro Infrared Oven power head when roasting. For steaming, loosely wrap the vegetables, with a sprinkle of water, in aluminum foil to circulate steam around the vegetables. To prepare vegetables that are steamed with a roasted flavor, remove the aluminum foil for the last two minutes of cooking time.

For succulent steamed spinach, place spinach, a pat (1 ounce) of butter, salt and pepper inside aluminum foil. Add a sprinkle of water. Seal the edges. Place on 1" rack and cook on power level HI for about 10 minutes or until tender.

Place aluminum foil on top of vegetables if they begin to brown too quickly.

Baking Recommendations

For baked potatoes or sweet potatoes, wash potatoes thoroughly and place potatoes on either rack and heat on HI for the times listed below or until a fork is easily inserted.

(Based on medium potatoes)

Whole potatoes:	45-47 minutes
Half potatoes:	25-30 minutes
Quarter potatoes:	15-25 minutes

(Vegetables listed below are all fresh. Cooking time will vary depending on size of vegetable)

Corn on the Cob:	5 min/per side
Root Vegetables:	20-30 minutes
Broccoli:	5-8 minutes
Acorn Squash	30 minutes
Butternut Squash	35 minutes
Eggplant whole	30 minutes
Eggplant ½" slices	12-15 minutes

Zucchini and Onions au Gratin

- 1 large yellow onion
- 1 medium zucchini
- ½ teaspoon salt
- ⅛ teaspoon pepper
- 1 tablespoon olive oil
- ½ cup shredded Cheddar cheese
- salt & pepper to taste

Chop onion into ½" pieces. Place in liner pan. Drizzle with olive oil. Cook on power level HI for 10 minutes, stirring halfway through. Slice zucchini into ¾" slices. Layer on top of onions. Season with salt and pepper. Cook on power level HI for 5 minutes. Sprinkle with cheese and cook for an additional 2 to 4 minutes. (2-4 servings)

Haricots Amandine

- 12 ounces French green beans, trimmed and rinsed
- 2 tablespoons olive oil
- juice from 2 fresh lemons
- ½ cup sliced almonds
- 2 tablespoons butter, melted
- 1 cup crispy canned or bagged prepared fried onion ringlets

Place green beans in an 8" x 8" shallow baking dish. Drizzle the oil and lemon juice over the beans. Cook on power level HI on 1" rack for 7 minutes. Top beans with almonds, butter and onions. Cook on HI for an additional 3 minutes. Serve immediately. (6-8 servings)

Mexican Style Corn on the Cob (Elote)

- 4 ears of corn
- ¼ cup melted butter
- ¼ cup mayonnaise
- ½ cup grated Cotija cheese or Queso Fresco cheese
- 4 wedges of lime (optional)
- chili powder or paprika to taste
- salt & pepper to taste

Place ears of corn on 4" rack and roast on power level HI for 7-8 minutes per side. Take out the corn and immediately pour butter on each ear then spread mayonnaise on them. Sprinkle with cheese, chili powder, salt and pepper to taste. Serve with lime wedges. (2-4 servings)

Balsamic Glazed Carrots

- 1 lb. fresh carrots, washed and cut into thin round slices
- 2 tablespoons olive oil
- 1 teaspoon salt
- ½ teaspoon black pepper
- 2 tablespoons Balsamic vinegar
- 1 tablespoon brown sugar
- salt & pepper to taste

Place all wet ingredients in a bowl and add the carrots. Season with salt and pepper. Place in the 12" liner pan and cook in the NuWave for 12 minutes on power level HI. (6 servings)

Italian Onions

- 1 large red onion
- Italian dressing

Cut both ends of the red onion, peel skin of onion. Pour ¼ cup of the Italian dressing over the onion and place on 4" rack. Cook on power level HI for 15 to 20 minutes. Use Italian dressing to dip onion in. Serve immediately.

(4-6 servings)



Asparagus with Parmesan Crust 🍷💡

- *This recipe is an excellent way to take advantage of the freshness of the season. When choosing asparagus, always look for the tips to be closed. This ensures freshness.*

- 1 lb. asparagus
- 1 tablespoon extra virgin olive oil
- 1 ounce Parmesan cheese, shaved
- ¼ cup Balsamic vinegar
- black pepper to taste

Wash and trim the asparagus. Toss the asparagus with olive oil. Place on the 4" rack. Arrange cheese on the asparagus and cook in the NuWave on power level HI for 5 to 6 minutes (keep in mind that cooking times may vary a few minutes each way depending on the size of the vegetables). Drizzle Balsamic vinegar over the asparagus and enjoy.

(6 servings)

Asparagus 💡

- 1 lb. fresh asparagus
- olive oil to taste
- garlic powder to taste
- salt & pepper to taste
- Italian or Greek dressing for dipping (optional)

Wash and trim 1 lb. of fresh asparagus and spread over the 4" rack. Spray with oil and season with garlic powder, salt, and pepper. Cook on power level HI for 5 minutes.

(4-6 servings)

Tips: Sprinkle sesame seeds on asparagus before cooking.

Parmesan Fries

- 2 large baking potatoes
- ½ cup Parmesan cheese
- olive oil to taste
- salt & pepper to taste

Cut off ½" from the ends of two large baking potatoes. Cut ½" off the sides to make a square sided potato. Cut, lengthwise, into ½" fries. Toss with olive oil and salt and pepper. Lay on 4" rack and cook on power level HI for 20 minutes or until crisp, turning halfway. Before serving, toss with ½ cup of grated Parmesan cheese.

(2-4 servings)

Roasted Herb Potatoes 🍷

- *These roasted potatoes will become your replacement for French fries. Sometimes I cut them into strips and serve them with a garlic mayonnaise as an appetizer.*

- 3 lbs. small new potatoes
- 2 tablespoons olive oil
- 1 tablespoon salt
- ½ teaspoon black pepper
- 2 tablespoons fresh rosemary, coarsely chopped or 1 teaspoon dried (use your favorite herb)
- 4 cloves garlic, thinly sliced

Cut potatoes into 1" pieces (if potatoes are small, leave whole) and place in a large bowl. Toss with olive oil, salt, pepper, herbs and garlic. Place on the 4" rack and cook on power level HI for 20 to 25 minutes, depending on the size of your potatoes. Halfway through, push the PAUSE button, turn the potatoes, and then hit START button to resume cooking.

(6 servings)

Eggplant Parmesan Casserole

- olive oil
- 1 large eggplant, thinly-sliced
- 1 cup shredded Parmesan cheese
- 2-3 basil leaves, torn
- 1½ tablespoons minced garlic
- 1 large tomato, thinly sliced
- dash of sea salt
- 1 cup Mozzarella cheese

Use a 9"-10" oven safe baking pan and spread a little olive oil on the bottom of the pan. Using at least 2 layers, start the layers with the eggplant and end with the cheese in the order above. Place dish on 1" rack and cook on power level HI for 20 minutes. Slice in serving slices and enjoy!

(4-6 servings)

Potatoes Au-Gratin Nuwave Style 🍷

- *This recipe is done in our 10" baking pan. You can put this in any pan you would put in your conventional oven. The thinner you can cut the red potatoes the better. You can also use Yukon gold potatoes. This is a great side-dish with any meal.*

- 6 cups small red potatoes, washed and sliced very thinly
- ½ cup diced red or white onion
- 2 cloves chopped garlic
- 4 tablespoons butter
- ½ cup Parmesan cheese
- ½ cup heavy cream
- 3 tablespoons chopped parsley (if you dry add 1 tablespoon)
- salt & pepper to taste

Wash slice and place potatoes in a bowl. Add chopped onion, butter, cheese, cream and spices. Mix and place in the 10" baking pan. Press the potatoes down into the pan. Place on the 1" rack and cook on power level HI for 20 minutes. Let sit for 2 minutes with dome lid on.

(6 servings)

Sweet Potato Casserole

- 4 sweet potatoes
- ⅓ cup butter
- ½ cup sugar (¼ cup for less sweet)
- 2 eggs, slightly beaten
- ½ teaspoon salt
- 1 teaspoon vanilla
- 1 teaspoon flour

Place sweet potatoes on the 4" rack and cook on power level HI for about 45 minutes, or until a fork is easily inserted. Allow to cool for about 15 minutes. Peel sweet potatoes. Place the sweet potatoes in a medium bowl and mash. Add the butter, sugar, eggs, salt, vanilla and flour; mix well. Place in a 1½ quart casserole dish. Place on 1" rack and cook on power level HI for 20 minutes.

Streusel Topping:

- ¼ cup flour
- 3 tablespoons butter, softened
- ½ cup brown sugar (¼ cup for less sweet)
- ¼ cup pecans, chopped

To make the streusel topping, combine flour, butter, sugar and pecans and blend with fork until crumbly. Remove dome and stir sweet potatoes. Spread streusel topping on casserole and continue baking for an additional 15 minutes.

(4-6 servings)



Double Stuffed Potatoes

- 4 russet potatoes, skins thoroughly washed
- 2 tablespoons butter
- ½ teaspoon salt
- ⅛ teaspoon pepper
- ¼ cup sour cream
- ½ cup shredded Cheddar cheese

Cook potatoes on 4" rack until a fork is easily inserted about 45 to 60 minutes on power level HI. Cool potatoes for about 15 minutes until you can handle them comfortably. Cut potatoes in half lengthwise. Carefully scoop out centers into a medium bowl leaving a durable shell. Smash the scooped out potatoes. Add the butter, salt, pepper, sour cream and ¼ cup of cheese. Stir with spoon. Fill each potato shell with equal amounts. Place on 4" rack and cook on power level HI for 10 minutes. Sprinkle with remaining stuffed cheese and bake for an additional 2 minutes.

(4 servings)

Roasted Garlic Pate

- 8 cloves fresh garlic
- 2 tablespoons olive oil
- 2 tablespoons extra virgin olive oil
- salt & pepper to taste

Trim the tops and bottoms of the garlic heads and toss in a plastic bag with the oil. Place in the liner pan and sprinkle with salt and pepper to taste. Cook on power level HI for 20 to 30 minutes or until garlic is soft and golden brown. Cool until it can be handled and squeeze the soft garlic cloves into a bowl. Mash with a fork adding the extra virgin olive oil as you mash. Re-season with salt and pepper to taste. Serve with French bread slices.

(8 servings)

Mixed Vegetable Casserole

- I'm not sure where I got this recipe, it's not mine originally, and I'm usually a stickler for fresh vegetables but....Sometimes you just have to make do with what's on hand.

- 1 (15 ounce) can Veg-All®, drained vegetables
- 1 (8 ounce) can sliced water chestnuts, drained
- 1 cup grated sharp Cheddar cheese
- 1 cup celery, finely chopped
- ¾ cup mayonnaise
- 1 small onion, finely chopped
- 20 Ritz® crackers, crushed
- 2 tablespoons melted butter

In a large bowl, mix the vegetables, chestnuts, cheese, celery, mayonnaise and onion. Transfer to the 10" greased baking pan or a casserole pan that will fit into the NuWave. Place on the 1" rack and on power level HI, bake for 15 to 17 minutes. Combine the crackers and butter, and 2 minutes before casserole is done sprinkle with cracker mixture and continue to cook until brown. Let dome sit on oven for 1 to 2 minutes before removing the pan.



Corn Soufflé

- I grew up with this recipe. When corn was in season we'd use fresh. This is one of those comfort foods.

Notes: Use the 10" baking pan or a round casserole pan that fits in the NuWave. Keep in mind that if the pan is bigger, you need less cook time. If pan is deeper, you should cook longer.

- 1 package Jiffy corn mix
- 1 (15 ounce) can regular canned corn-drained
- 1 (15 ounce) can cream-style corn-drained
- 1½ cup shredded Cheddar cheese
- 1 teaspoon salt
- 4 eggs, beaten
- ¼ cup sugar

Mix all ingredients together and mix well. Pour into the 10" baking pan that has been sprayed with non-stick spray. You can also use a casserole pan or an 8" x 8" pan. Place on 1" rack and cook on power level HI for 30 minutes. If you are using a casserole pan or an 8" x 8" pan, cook for 35 minutes. When timer goes off let sit with dome lid on for 2 minutes.

Parmesan Basil Tomatoes

- 4 red tomatoes
- 2 tablespoons grated Parmesan
- 3 tablespoons fresh chopped basil
- 2 tablespoons olive oil
- cracked pepper to taste

Trim top third of tomatoes and discard. Trim thin slices from the bottoms so the tomatoes sit securely. Mix together the remaining ingredients and divide on tops of the tomatoes. Place on foil on 4" rack and cook on power level HI until cheese bubbles and browns and tomatoes are warm, about 7 to 9 minutes.

(4 servings)

Cheese Stuffed Tomatoes

- This recipe is an excellent way to take advantage of the freshness of the season. These are good any time of the year. I use the tomatoes as a side dish or as an appetizer. We all have these items in our pantry.

- 3 Roma tomatoes or any of your favorite type.
- 1 cup Mozzarella cheese
- ½ cup Parmesan cheese
- 1 tablespoon fresh thyme or dried (use have amount for dried herbs)
- 1 tablespoon fresh basil
- ¼ cup onion, chopped
- 1 tablespoon garlic, chopped
- ¼ teaspoon black pepper

Arrange tomatoes cut side up in a single layer on the 4" rack. Place cheese and all other ingredients together and stuff into tomatoes. Cook in your NuWave oven on power level HI for 6 minutes. The cheese will be bubbly and brown.

(6 servings)





TIPS FOR BEEF

Always turn beef halfway through the cooking time for even browning.

To use your favorite dry seasonings on frozen meat, sprinkle a little water on top of the meat and then add your seasonings. This will allow the seasonings to stick to the meat.

Brush sauces on fresh meat so the seasonings bake right in.

To save time, marinate meat in a sealed bag or container and freeze into separate servings. For appropriate cooking times, refer to the cooking guide for frozen meat.

** Using a meat thermometer is essential for checking the internal temperature of the meat.*

Steak Diane

- 2 lbs. sirloin or strip steak, (1" thick)
- 4 tablespoons butter
- 1 tablespoon Cognac or Brandy
- 2 tablespoons Sweet Sherry
- 1 tablespoon chives, minced
- salt & pepper to taste

Place butter, Brandy, Sherry, and chives in a 10" pie plate and set on the liner pan. Season the meat and place on 4" rack. Cook on power level HI for 5-6 minutes per side or to desired temperature and transfer to serving plate. Pour sauce over steaks. Cut the steak into 1" thick slices and serve with remaining sauce.

Frozen: 11 minutes per side
(4 servings)



Cube Steak with Parsley Butter

- 1 cube steak
- 2 tablespoons butter
- 2 tablespoons minced parsley

Place the steak and butter in a shallow dish and place on the 4" rack. Cook on power level HI for 5 to 7 minutes depending on how well done you like your steak. Sprinkle with parsley before serving. (1 serving)

Fool-proof Standing Rib Roast

- Follow this method for a rib roast that is wonderfully browned on the outside and medium rare on the inside. For medium to well done beef follow the Quick and Easy Cooking Guide for estimated times.

- 1 (5 lbs.) standing rib roast, thawed if frozen
- 1 teaspoon onion powder
- 1 teaspoon Kosher salt
- 1 teaspoon black pepper

Let thawed rib roast sit out for ½ hour. Beef needs to be at room temperature. Rub roast with seasonings. Place on 1" rack. Rib side down. Cook on power level HI for 15 minutes a pound for rare, 18 minutes a pound for medium rare, 20 minutes a pound for medium, 23 minutes per pound for well done. (6-8 servings)

Meatballs

- 1 lb. ground beef
- 1 cup bread crumbs
- ½ cup prepared spaghetti sauce
- 2 cloves garlic, minced
- ½ medium yellow onion, minced
- 1 tablespoon dry Italian herbs
- 2 large eggs
- ¼ cup grated Parmesan cheese

Mix everything and form 2" balls. Place on the 4" rack and cook on power level HI for 8 to 10 minutes, turning halfway. (6-8 servings)

Japanese Style Steak

- 1 (4-6 ounce) sirloin steak
- ¼ cup miso paste (available at Asian food stores)
- 2 tablespoons sake or dry white wine
- 2 tablespoons pickled ginger slices

Mix the miso and sake and spread over the steak and marinate for 1 hour in a shallow dish. Cook on the 4" rack on power level HI for 5 minutes per side and serve with the ginger. (1 serving)

Sicilian Style Steak

- 1 (4-6 ounce) sirloin or rib steak
- 2 teaspoons grated Parmesan cheese
- 1 canned anchovy filet
- ¼ cup canned, chopped tomato
- 1 tablespoon capers
- 1 tablespoon olive oil

Cook the steak on the 4" rack on power level HI for 5 minutes per side. Meanwhile mix the other ingredients. Spread the mixture over the steak and cook another 3 minutes. (1 serving)

London Broil in a Dish

- 1 (6 ounce) sirloin steak sliced into ½" strips
- 2 large white mushrooms, sliced
- 1 tablespoon Worcestershire sauce
- 1 tablespoon butter
- salt & pepper to taste

Place everything in a shallow dish and cook on the 4" rack on power level HI for 10 minutes. (1 serving)

Beef and Andouille Burgers with Caramelized Onions and a Spicy Mayonnaise 🍴

- My neighbor down in New Orleans had us over for a BBQ and I'll never forget this burger. He graciously gave me the recipe which I'm sharing with you.

- ½ lb. Andouille sausage, cut into ¼" cubes (ask your butcher where to find the Andouille sausage)
- ½ lb. ground beef chuck or ground beef (20 percent fat)
- ¾ cup pecans, toasted, chopped
- 1 teaspoon salt
- ¼ teaspoon black pepper

Mix all ingredients together and shape into 6½" thick patties. Put in refrigerator while fixing the rest of burger.

Caramelized onions:

- ½ lb. sweet onion
- 2 tablespoons extra virgin olive oil (more to brush on rack)
- 3 tablespoons garlic cloves, minced
- 1 teaspoon brown sugar

Place all the ingredients for caramelized onions on the 12" liner pan and cook on power level HI for 10 minutes. Remove and keep warm.

Spicy Mayonnaise:

- ¾ cup mayonnaise
- 1 tablespoon fresh lemon juice
- 1 teaspoon Cajun or Creole seasoning blend
- ¼ teaspoon hot pepper sauce

Place your burger on the 4" rack (that has been sprayed or brushed with oil) and cook on power level HI for 4 to 5 minutes per side. Place burgers on bun, add onions and top with mayonnaise.

Beefy Italian Skillet 🍴

- Slowly simmer beef round steak in an herb-packed tomato and mushroom sauce for entrée fork tender. This is great comfort food.

- 1 lb. boneless beef round steak
- 2 cups fresh mushrooms, sliced
- 1 cup onions, chopped
- 1 cup green sweet pepper, coarsely chopped
- ½ cup celery (1 stalk), chopped
- 2 cloves garlic, chopped
- 1-14½ ounce can tomatoes (un-drained and cut up)
- ½ teaspoon dried basil
- ¼ teaspoon dried oregano
- ¼ teaspoon crushed red pepper
- 8 ounces dried whole wheat or regular spaghetti
- 2 tablespoons grated Parmesan cheese

Trim the fat from meat. Cut into four even serving-size pieces. Lightly coat your 12" liner pan with non-stick cooking spray. Add meat to pan. Cook on power level HI for 5 minutes each side on the 4" rack. Add all vegetables and seasonings to meat. Remove meat and vegetables and turn rack over to 1". Cook meat and vegetables on the 1" rack on power level HI with foil for 40 minutes. While cooking meat, cook your spaghetti according to package directions. Serve meat and vegetables over spaghetti and sprinkle with Parmesan cheese.

(4 servings)

Steak with Roasted Garlic and Chili Rub 🍴

- To give your steak an Italian, instead of a Southwestern flavor, substitute equal amounts of dried basil for the chili powder and dried thyme for the cumin.

- 1½ lbs. boneless sirloin steak
- 4 large cloves of garlic, peeled
- 1 teaspoon chili powder
- 1 teaspoon ground cumin
- ½ teaspoon dried oregano
- ¼ teaspoon salt

Wrap garlic in tin foil and place on 4" rack and roast on power level HI for 15 minutes. Take softened garlic from the oven, and when cooled, mash in small bowl and add all other spices. Rub garlic and spices on both sides of the steak. Place on the 4" rack and on HI cook 6 to 7 minutes per side for medium rare. Refer to Quick and Easy Cooking Guide for recommended cooking times.

Beef and Corn Casserole with Noodles 🍴

- 1 lb ground beef
- ½ cup chopped onions
- 1 can cream-style corn (15 ounce)
- 1 can corn nibblets-drained (11 ounce)
- 1 can tomato sauce (8 ounce)
- 1 can tomato soup
- 1 package noodles (12 ounce, such as macaroni noodles)

Cook the noodles according to the package directions. Drain and rinse. Brown beef and onions until beef is browned and onions are cooked through. Add soup, tomato sauce and corn to beef mixture. Mix noodles with beef and sauce mixture. Pour into 12" liner pan. On the 1" rack, cook for 20 minutes on power level HI.

(1 pie plate)

Homestyle Meatloaf 🍴

- An old standby and still a favorite. You can use any ground meat you want, pork, turkey, veal or chicken.

- 1 tablespoon olive oil
- 1 medium onion, chopped
- 3 garlic cloves, finely chopped
- 1½ lbs. lean ground beef
- 1 large egg
- ½ cup dry bread crumbs
- ½ cup ketchup or chili sauce
- 1 tablespoon Worcestershire sauce
- 1 tablespoon Dijon mustard or any mustard
- 1 tablespoon dried Italian seasonings

In a small skillet, heat oil over medium-high heat. Add onion and garlic. Cook until soft about 3 minutes. In a large bowl, combine all of the above ingredients except the topping ingredients. Mix well. Pack into a 4" x 8" loaf pan. For topping, combine ketchup and mustard in a small bowl and spread over the top of the loaf. Place on the 1" rack and cook on power level HI for 35 minutes (if the meat starts to get too brown, loosely cover with foil). Pop in a couple baked potatoes on the 4" rack, at the same time as meatloaf and when loaf is done, add another 7 minutes to the potatoes. This will allow your meatloaf to sit and rest.



Pepper Steak (steak au poivre)

- 1-2 lbs. sirloin steak
- salt to taste
- ½ cup crushed peppercorns
- 4 ounces butter, melted
- ¼ teaspoon cayenne pepper
- 3 tablespoons Worcestershire sauce
- 1 tablespoon lemon juice
- 1 tablespoon parsley, chopped

Place the butter pepper and Worcestershire sauce in a 10" pie plate on the liner pan. Salt the meat and press the pepper into both sides of the meat and lay on the 4" rack. Cook on power level HI for 5 to 6 minutes, turn over and cook another 5 to 6 minutes. Cut into 1" strips and serve with remaining sauce.

(4-6 servings)

German Style Beef Rollups (Mock Roladen) ♥

- 1 (5 ounce) slice of sirloin pounded to ⅜" thick
- 1 tablespoon course ground mustard
- ¼ cup white part only of a scallion, thinly sliced
- 1 medium garlic pickle, sliced lengthwise in half
- ½ cup chopped carrot

Spread the mustard over the meat and lay on the vegetables. Roll up and secure with a toothpick. Spray with vegetable oil and cook on the 4" rack on power level HI for 8 minutes.

(1 serving)

Korean Style Ribs

- 2 meaty ribs from a prime roast
- 4 tablespoons Korean style barbecue sauce
(available at Asian food stores)

Place the ribs and sauce in a plastic bag and marinate for one hour. Place the ribs on the 4" rack and cook on power level HI for 5 minutes per side.

(1 serving)

Mexican Dinner

- 1 (10 ounce) flank steak, chicken, or pork
- 1 large Spanish onion
- 1 green pepper
- 1 red pepper
- 1 yellow pepper
- 1 package of taco or fajita seasoning mix
- 8 ounces package shredded Mexican or Cheddar cheese
- 1 package ready-made tortilla's favorite salsa
- salt & pepper to taste

Cut all vegetables and meats into 3" x ¼" long strips. Sprinkle or roll meats with seasoning mix. On 4" rack, place vegetables around outside and meats on inside (can be in shallow piles to fit). cook on power level HI for 8 minutes. Open the dome, turn vegetables and meats over, and place tortillas below on the liner pan wrapped well in aluminum foil. Cook on power level HI for another 8 minutes or until meats are done. Carefully open foil and place meats and vegetables on warmed tortillas. Top with cheese and salsa. Roll up the tortilla's and enjoy.

(2 servings)

Meat Loaf Italiana 💡

- 1½ lbs. ground beef
- 2 large eggs
- ¾ cup fine dry bread crumbs
- 2 tablespoons Italian style herb blend
- 1 cup spaghetti sauce
- 2 slices bacon

Mix everything, except the bacon and pat mixture into loaf shape pan and place on 1" rack. Lay the bacon on top of the mixture and cook on power level HI for 35 minutes.

Tips: Add ½ cup of Mozzarella cheese to the center of the mixture.

(6-8 servings)

Beef Brisket 💡

- 2-3 lbs. frozen brisket
- 6 bay leaves
- 10 garlic cloves
- 2 tablespoons turmeric
- 1 cup beef stock
- salt & pepper to taste

Place everything in a plastic cooking bag** and lay on the 4" rack. Cook on power level HI for 1½ hours. Carefully turn bag over and cook an additional 60 minutes or until meat is tender.

****Note:** Making slits in the cooking bag will result in juices escaping from the bag. Gather the open end of the bag, leave a thumb size opening and tie with string or ties.

(4-6 servings)

Corned Beef Brisket 💡

- 2-3 lbs. frozen brisket
- 1 cup beef stock
- 10 peppercorns*
- ⅛ teaspoon cloves*

*Add cloves and peppercorns if your corned beef does not include seasoning packet.

Rinse off the meat and place everything in a plastic cooking bag.** Lay on the 4" rack. Cook on power level HI for 1½ hours. Carefully turn bag over and cook an additional 60 minutes or until meat is tender.

****Note:** Making slits in the cooking bag will result in juices escaping from the bag. Instead gather the open end of the bag, leave a thumb size opening and tie with string or ties.

(4-6 servings)

Tips: Serve with potatoes, cabbage and rye bread for that St. Patrick's Day touch!

Classic NuWave Pot Roast

- 2½ lbs. chuck or shoulder roast
- 1 tablespoon olive oil
- fajita seasoning mix
- 2 potatoes, peeled and cut into quarters
- 1 cup small carrots
- 1 large yellow onion, peeled and cut into quarters

Brush roast with olive oil and season with fajita seasoning. Place Roast on the 1" rack, fatty side up and cook on power level HI for one hour. Brush remaining vegetables with oil and sprinkle fajita seasoning mix. Turn the roast and place the vegetables around the roast. Cook on power level 7 for 30 minutes. Let roast sit at least 10 minutes before serving and enjoy!

(4-6 servings)

Mock Chinese Casserole 🍲

- 1½ lbs. ground beef
- ½ cup celery, chopped
- 1 cup onion, chopped
- ½ cup sliced mushrooms
- 1 cup instant rice
- 1 can cream of mushroom soup
- 1 cup water
- ¼ cup soy sauce
- 1 can or small bag Chow Mein noodles

Brown ground beef and vegetables together. Drain the excess fat. Add rice, soup, water and soy sauce. Bring to a bubbling boil around edges of the pan. Place in the 10" baking pan. On the 1" rack cook for 15 minutes on power level HI Place Chow Mein noodles over the top. Cook for an additional 2 minutes on power level HI.



TIPS FOR LAMB

To use your favorite dry seasonings on frozen meat, sprinkle a little water on top of the meat and then add your seasonings. This will allow the seasonings to stick to the meat.

Brush sauces on fresh lamb so the seasonings bake right in. To save time, marinate meat in a sealed bag or container and freeze into separate servings. When ready to use, refer to the cooking guide to cook frozen meat.

Lamb is thoroughly cooked when the exterior appears crispy and dark brown in color and the meat begins to split apart. Use a meat thermometer to be sure the lamb is properly cooked.

When the lamb roast is within 41° F (5° C) of its internal temperature (see Roasting Recommendations below), remove from the oven, place an aluminum foil tent loosely over it, allowing the meat to rest for 15 to 20 minutes. As the meat rests, the internal temperature will increase by several degrees.

Roasting Recommendations

(Temperatures listed below are based on internal temperatures)

Lamb Cuts	135°-145°F (63°C)
Lamb Roasts (Boneless)	145°-150°F (66°C)
rare	120°-140°F (60°C)
medium-rare	140°-150°F (66°C)
medium-well	150°-160°F (71°C)

** Using a meat thermometer is essential for checking the internal temperature of the meat.*

Herb Stuffed Lamb Chops

- Lamb Chops are something more people should cook. The earthiness of the meat paired with the fresh herbs round this meal into a wonderful dinner. Have your butcher cut a 2" pocket into the side of the lamb. You can also cut pocket yourself. Lay meat chop side down and depending on the size of the chop cut a pocket ¾" through the side of the lamb. I love thyme or tarragon with lamb. Some people like rosemary, so use the herbs you like.

- 6 each lamb chops (2" thick)
- 1 stick soft un-salted butter
- 3 cloves garlic, minced
- 1 tablespoon fresh parsley, chopped
- 1 tablespoon fresh tarragon, chopped or 1½ teaspoons dried
- 1 large shallot, chopped
- ¼ teaspoon ground black pepper
- 1 teaspoon salt

Mix garlic, herbs, shallots, salt and pepper with the softened butter. Place butter mixture in pockets of lamb. Secure with toothpicks. Spray non-stick cooking spray on the 4" rack and place the lamb chops on the rack. Cook on power level HI for 9 minutes per side for medium rare. If you want well-done, cook for 12 minutes per side. (6 servings)

Lamb & Ham

- 6 ounces leg of lamb cut into 1" cubes
- 2 ounces smoked ham, diced
- ½ green pepper, cored and chopped
- 1 clove garlic, minced
- 2 tablespoons olive oil
- salt & pepper to taste

Mix everything in a shallow dish and place on the 4" rack. Cook on power level HI for 8 minutes, stir and cook another 8 minutes.

(1 serving)

Lamb with Pesto

- 1 (6 ounce) lamb steak from the leg (1" thick)
- 3 tablespoons pesto sauce

Place the steak on the 4" rack and spread on half the pesto sauce. Cook on power level HI for 8 minutes. Turn over and spread on the remaining sauce and cook for another 8 minutes. (1 serving)

Pesto Sauce:

- 2 cups packed fresh, basil leaves
- ⅓ cup pine nuts
- 2 cloves garlic
- ½ cup olive oil
- salt to taste

Place the basil, nuts, and garlic in your food processor or blender. With the machine running slowly pour in the oil until it forms into a thick paste. Add more oil if too thick. Season and store in a jar with a thin film of mayonnaise on top to prevent discoloration.

Lamb Kabob

- 2 lbs. leg of lamb, trimmed of fat, and cut into 2" cubes
- 1 large green bell pepper, cored and cut into 8 equal pieces
- 1 red onion quartered
- 8 large white mushrooms
- 4 Roma style tomatoes, cut in half and seeded
- barbecue sauce

Divide ingredients into four servings and slide onto metal or bamboo skewers, alternating meat and vegetables. Place on the 4" rack and brush with sauce or seasoning. Cook on power level HI for 10 minutes, then turn and brush the other side with sauce or seasoning and cook an additional 5 minutes.

(4 servings)

Moroccan Lamb Burgers 🍷❤

- I love the international flavor of this burger. With the mildly spicy North African flavors this burger is a crowd pleaser.

- 1½ lbs. ground Lamb (you can use beef or turkey)
- 1 clove garlic, minced
- 1 Jalapeno chile, seeded and minced
- 2 tablespoons fresh cilantro, chopped
- 1 large shallot
- ¾ teaspoon ground black pepper
- 1 teaspoon salt
- ½ teaspoon paprika
- ½ teaspoon ground cumin

Salsa:

- 2 tablespoons extra virgin olive oil
- 1 tablespoon fresh lemon juice
- 1 tablespoon honey
- 2 large orange, peel and pith cut away (cut oranges into ½" cubes)
- 1 cup chopped red onion
- ¼ cup chopped pitted green olives (I use Greek)

Mix all the ingredients in the lamb section and form into four 4" burgers. You can make these the day ahead, if you want. This helps to marry flavors. Spray non-stick cooking spray on the 4" rack and place burgers on the rack. Cook on power level HI for 4 to 5 minutes per side. If you want well-done, cook for 7 to 8 minutes. Place on your favorite bun (I recommend cracked wheat) and place salsa on burger along with mayonnaise.

(4 servings)

Curried Lamb ❤

- 6 ounces leg of lamb cut into 1" cubes
- ½ green pepper, sliced thick
- 2 cloves garlic, minced
- 2 tablespoons grated fresh ginger
- 2 tablespoons curry paste (available at Asian markets)
- 1 tablespoon lemon juice
- 4 tablespoons sour cream

Mix everything, except the juice and sour cream, in a shallow dish. Place on the 4" rack and cook on power level HI for 10 minutes, stir and cook for another 10 minutes. Stir in the juice and sour cream and serve.

(1 serving)

Lamb Chops with Feta and Tomatoes

- 2 tablespoons olive oil
- 1 clove garlic
- 1 tablespoon lemon juice
- 4 lamb chops, 1" thick
- 4 ounces feta cheese, crumbled
- ¼ cup chopped ripe tomatoes
- 4-6 pitted Kalamata olives
- 1 tablespoon chopped parsley
- salt & pepper to taste

In shallow dish, mix olive oil, garlic and lemon juice. Add the lamb chops and turn to coat on all sides. Place in refrigerator for 15 minutes. In a small bowl, mix feta, tomatoes, olives, and parsley. Set aside. Place lamb chops directly on 4" rack, sprinkle with salt and pepper. Cook on power level HI until done to taste, approx. 8 to 10 minutes, turning over halfway.

When chops are done, spoon equal portion of feta mixture on each chop and cook on HI for 1 to 3 minutes or until cheese melts.

(4 servings)



TIPS FOR POULTRY 💡

Poultry should be turned halfway through the cooking time for even browning.

To use your favorite dry seasonings on frozen poultry, sprinkle a little water on top of the poultry and then add your seasonings. This will allow the seasonings to stick to the poultry.

Brush sauces on fresh poultry so the seasonings bake right in.

To save time and for extra flavor, marinate poultry in a sealed bag or container and freeze into separate servings. When ready to prepare, refer to the cooking guide for appropriate cooking times.

To prevent poultry from browning too fast, place aluminum foil over the top. Be sure to secure the aluminum foil to the sides of the rack or extend the aluminum foil outside the oven to prevent the internal fan from moving the aluminum foil around during the cooking process.

Turkey Tip: Start cooking the turkey, breast side down for the first half of the cooking time. When you flip the turkey breast side up, if there are giblets in the turkey, the insides should be thawed enough to remove them at this time. During the last 20 to 30 minutes of cooking, stuff cavity with your favorite stuffing and resume cooking.



Poultry: White meat will be white; thigh meat near the bone will have no pink color, and the juices will run clear.

** Using a meat thermometer is essential for checking the internal temperature of the meat.*

Nuwave®
PRO INFRARED OVEN

Stuffed Chicken with Goat Cheese and Red Pepper Sauce 🍗

- I love this recipe for the bigger chicken breasts you can find at the market. If you want to use thinner chicken breasts, have the butcher pound the chicken breast to about a ¼" thick. This is perfect to make and freeze. I always make a couple extra dinners to have on hand. This way after a hard day you can pull out of the freezer and have a great healthy meal in no time. Remember, Nuwave cooks from a frozen state and spares no flavor or juices.

- 4 boneless chicken breasts (on the thicker side or ¼" flatten chicken breasts)
- 4 ounces mild Goat cheese
- 2 tablespoons olive oil
- 1 tablespoon fresh thyme, chopped or ½ teaspoon of dry thyme
- 1 tablespoon fresh basil, chopped or ½ teaspoon dry basil
- 2 cloves garlic, chopped
- pepper to taste

In a small bowl, add all ingredients and mix. Place chicken breast on the cutting board with breast side up and cut a 3" pocket in the side of the breast. Stuff breast with cheese mixture. Fasten the slit with toothpicks. For thinner breasts, lay the flatten breasts on the cutting board and place the cheese in the middles of the breast and roll the chicken and secure with toothpicks.



Cooking instructions for thicker chicken breasts:

Place on the 4" rack and brush with olive oil and sprinkle with paprika. Cook on power level HI for 16 minutes for thawed, larger thicker breasts. Cook for 24 minutes for a frozen breast. No need to turn the chicken.

Cooking instructions for thinner breasts:

Place on the 4" rack and brush with olive oil and sprinkle with paprika. Cook on power level HI for 12 minutes for thawed breast and 20 minutes for frozen chicken. No need to turn the Chicken.

Easy Red Pepper Sauce:

Cut 2 cups of red peppers in half. Remove seeds. Place on the 4" rack and cook on power level HI for 12 minutes. Skin will peel off. Place the peppers in the NuWave Twister or a blender and add 1 teaspoon garlic and ½ cup chicken stock; salt and pepper to taste. Blend and place in the bottom liner pan. Heat on power level HI for 3 minutes. Place the chicken on sauce and serve. The liner pan can also be served as a tray.

(6 servings)

Cilantro Garlic Chicken Breast 🍗

- This sounds like a lot of cilantro and garlic, the result is a tangy. I serve with fresh slices of tomato and cucumbers. This recipe freezes wonderfully.

- 6 boneless, skinless chicken breasts (about 6 ounce)
- 4 cloves garlic, peeled
- 1 small onion, peeled
- 1 cup loosely packed fresh cilantro leaves
- 1 tablespoon granulated sugar
- 1 tablespoon soy sauce
- 1 teaspoon black pepper
- ¼ cup lemon or lime juice

Place one chicken breast between sheets of parchment paper or on plastic wrap (I cut open a plastic bag). With a meat pounder or rolling pin, flatten chicken until about ½" thick. Place in a large plastic bag. Repeat with remaining chicken breasts. In the NuWave Twister or blender, finely chop garlic, onions and cilantro. Blend in lemon juice, sugar, soy sauce and pepper. Pour over chicken. Refrigerate for 1 to 4 hours. You can also place in the freezer and have a meal ready at any time. To cook from the frozen state arrange chicken on the 4" rack. Cook on power level HI for 8 minutes per side (if thawed out, cook on power level HI for 6 minutes per side). Keep in mind these are estimated cooking times depending on the size of the chicken breasts.

(6 servings)



Chicken and Dumpling Casserole 🍗

- This recipe is done in the 10" baking pan. It can be done in a pie dish or any oven safe dish that you would use in a conventional oven. The ease of this recipe and the taste speaks for itself.

- 4 boneless, skinless chicken breasts (5-6 ounce, ½" thick)
- 1 can cream of mushroom or celery or any soup you like
- ¾ cup white flour
- 1 teaspoon baking powder
- ¼ cup Parmesan cheese, grated
- 1 teaspoon garlic powder
- ½ teaspoon paprika
- 2 tablespoons extra virgin olive oil
- 1 large egg
- salt & pepper to taste

Wash and dry the boneless, skinless chicken breast. Baste the cream of mushroom soup over chicken. In a bowl mix the rest of the ingredients. Spread mixture over chicken and soup mixture. Place 10" baking pan (or what ever pan you are using on the 1" rack) and cook on power level HI for 16 minutes. Please keep in mind that if you're using thicker chicken breasts or chicken with bones you will have to adjust your cooking time accordingly. Let dome sit for 1 minute before opening. (4 servings)

Breaded Chicken Breast

- 1 cup seasoned bread crumbs
- 2 tablespoons butter
- 1 egg, beaten
- 1 (4-6 ounce) boneless chicken breast
- 2 tablespoons chopped parsley

Place the bread crumbs in a shallow oval dish. Dip the chicken in the egg and roll in the bread crumbs. Place the butter on top and cook on power level HI on the 4" rack for 8 minutes. Sprinkle with parsley and serve.

(1 serving)

Nut Breading Chicken Breast ♥

- 1 egg, beaten or ¼ cup egg substitute
- ½ cup ground pecans
- 1 tablespoon wheat germ
- 1 teaspoon dried Italian seasoning blend
- 1 (4-6 ounce) chicken breast
- 2 tablespoons chopped parsley
- salt & pepper to taste

Mix the nuts, wheat germ, and seasonings in a shallow oval dish. Dip the chicken in the egg and roll in the nut mixture. Place on the 4" rack and cook on power level HI for 8 minutes. Sprinkle with parsley and serve.

(1 serving)

Thai Chicken ♥

- 1 (4-6 ounce) chicken breast, cut into bite size pieces
- 2 tablespoons Thai green curry paste
- 2 tablespoons grated fresh ginger
- 2 tablespoons minced garlic
- 2 tablespoons olive oil
- ¼ cup shredded raw coconut, unsweetened

Mix everything in a shallow bowl and place on the 4" rack. Cook on power level HI for 15 minutes, stir and serve.

(1 serving)

Chicken Breast Italiano 💡

- 1 (5 ounce) boneless chicken breast
- 2 ounces pepperoni sausage, chopped
- 2 ounces shredded Mozzarella or Monterey Jack cheese
- 1 ounce grated Parmesan cheese
- ¼ cup prepared spaghetti sauce

Pound the chicken to ¾" thick and lay on the sausage and cheese. Roll into a cylinder with the skin stretched over the top and secure with a toothpick. Place on the 4" rack and cook on power level HI for 13 minutes. While chicken is cooking, heat the sauce. Place the chicken roll in a serving dish and pour the sauce over.

Tips: To heat sauce in the NuWave, place sauce in an oven safe dish, place on liner pan or 1" rack and melt on power level HI for about 3 to 4 minutes.

(1 serving)

Lemon Chicken ♥

- 4 chicken breasts or thighs
- juice of a lemon*
- 1 cup dry vermouth or white wine
- lemon pepper seasoning
- 1 tablespoon cornstarch
- salt & pepper to taste

Place the chicken in an appropriate size shallow pan on 4" rack. Pour the wine and lemon juice over the chicken. Sprinkle with the seasonings. Cook on power level HI for 35 minutes, flipping once. To make the sauce, pour juices into a bowl and stir in the cornstarch. Heat 1 to 2 minutes or until thickened.

(4 servings)

Tips: 1 lemon yields about ¼ cup of juice.

Creamy Chicken Breast with Mushrooms & Peppers

- 1 (4-6 ounce) chicken breast
- 2 large mushrooms sliced
- ½ red, yellow, or green bell pepper, cut into 1" pieces
- ½ cup cream
- salt & pepper to taste

Place the chicken in a shallow oval dish. Add mushrooms and pepper along the sides of the chicken. Pour sour cream and seasonings over all ingredients. Place dish on the 4" rack and cook on power level HI for 13 to 15 minutes.

(1 serving)

Buttery Chicken Breast

- 1 (4-6 ounce) boneless chicken breast
- 2 tablespoons butter
- 4 tablespoons chopped parsley
- salt & pepper to taste

Place the chicken in a shallow oval dish and add the remaining ingredients. Place on the 4" rack and cook on power level HI for 8 minutes.

(1 serving)

Chicken Curry ♥

- 1 (4-6 ounce) chicken breast, cut into bite size pieces
- 1 scallion, cut into ½" pieces
- ½ green bell pepper, diced
- 2 cloves garlic, minced
- 2 tablespoons fresh ginger, grated
- 1 tablespoon curry powder or paste
- ¼ cup sour cream
- 1 teaspoon coriander leaves, chopped
- salt & pepper to taste

Mix everything, except the coriander and sour cream in a small bowl. Place on the 4" rack and cook on power level HI for 15 minutes. Stir in the cream and sprinkle with coriander and serve.

(1 serving)

Rosemary Chicken ♥ 💡

- 1 (3 lb.) whole chicken
- 4 tablespoons fresh chopped rosemary or 2 tablespoons dried
- 4 large cloves garlic minced
- 4 tablespoons olive oil
- salt & pepper to taste

Loosen the skin of the chicken by running a chopstick or plastic spatula handle between the skin and flesh of the bird. Mix the rosemary, garlic and olive oil. Pour the mixture under the chicken's skin and massage to all areas of the bird. Place, breast side down, on the 1" rack and cook on power level HI for 20 minutes. Turn the bird over and baste with the juices in the liner pan and cook for another 25 minutes.

(1 serving)



Chicken Servings with Salsa ♥

- 2 chicken legs and thighs
- 1½ cups prepared salsa
- 4 cloves whole garlic
- Mexican spice blend

Place the salsa in a shallow dish with the garlic and place the chicken on top. Sprinkle seasonings and place on the 4" rack. Cook on power level HI for about 15 minutes.

(2 servings)

Lemon Caper Chicken 💡

- 4 boneless chicken breasts
- juice of a lemon
- 1 cup dry vermouth or white wine
- 3 tablespoons of capers
- lemon pepper seasoning
- 1 tablespoon cornstarch
- salt & pepper to taste

Place the chicken in an appropriate size shallow pan on 4" rack. Pour the wine and lemon juice over the chicken. Sprinkle with the seasonings. Tent with foil and cook on power level HI for 15 minutes. Flip the chicken, pour some of the sauce from the pan on the chicken including some of the capers. Tent again with foil and cook on power level HI for 15 minutes or until juices run clear. To make the sauce, pour juices into a bowl and stir in the cornstarch. Heat 1 to 2 minutes or until thickened and pour over top.

(4 servings)

Tips: Warmer lemons produce more juice. To heat lemons in the NuWave, place lemon on the 4" rack and heat on power level HI for about 2 to 3 minutes.

Oven Fried Chicken Tenders with a Wasabi Dipping Sauce 🍳♥

- This chicken allows you to feel like you're eating fried chicken but without all the fats. It gives you the nice crunch that seems to satisfy the need for the crunch factor in our diets. You can serve this with any sauce.

- 3 boneless, skinless chicken breasts (about 1 lb. each, cut crosswise into ½" strips)
- ⅔ cup white flour
- 1 teaspoon baking soda
- ½ cup Parmesan cheese
- ½ teaspoon garlic salt
- ½ teaspoon paprika
- ½ teaspoon black pepper
- 1 egg, slightly beaten
- 3 tablespoons extra virgin olive oil

Spray the 4" rack with non-stick cooking spray. In a 1 gallon food storage plastic bag, mix flour, baking soda, cheese, garlic salt, and paprika. Dip the chicken strips into egg and place into bag. Seal bag, shake and coat chicken. Place chicken on the 4" rack. Repeat until all the chickens are coated. Drizzle the olive oil over the chicken (or you could spray with non-stick olive oil spray). Cook on power level HI for 12 minutes. Turn the chicken half way through the cook time (if using thicker chicken you will need to add a few more minutes per side).

(4 servings)

Wasabi Dipping Sauce:

- ½ cup mayonnaise
 - 2 teaspoons Wasabi (found in the refrigerator section at the local market)
- Mix together.

Tips: If you like a spicier sauce, add more wasabi. I also use honey mustard and BBQ sauces. When the timer goes off, let the chicken sit in the oven with the dome on for 1 minute. This allows the meat to rest.

Low-Fat Crunchy Filled Chicken

- 4 boneless chicken breasts
- 3 ounces low-fat Cheddar cheese
- 1 tablespoon Dijon mustard
- 1 cup crushed corn flakes
- 1 teaspoon dried parsley flakes
- ½ cup non-fat buttermilk

Cut a deep 2" long slit in the side of the meaty portion of the breast. Slice cheese into 4 portions and brush with mustard. Place 1 piece of cheese into each slit and secure with wooden toothpicks. Combine cereal, seasoning, and parsley. Dip chicken into buttermilk and roll in cereal mixture. Place chicken in baking dish which has been sprayed with non-stick spray and place on 4" rack. Cook on power level HI for 45 minutes, turn over halfway thru to evenly brown.

(4 servings)

Turkey Breast Enchiladas

- 4 (6 ounce) turkey cutlets
- 4 slices Mozzarella or Mexican white cheese, (about 4 ounce)
- ½ cup prepared salsa
- ½ cup sour cream
- chopped cilantro
- Mexican style seasoning to taste

Pound the turkey cutlets to ⅜" thickness and place on top cheese and seasonings. Roll up and lay, seam side down, around the edge of a pie plate. Spray with cooking oil and place on the 4" rack and cook on power level HI for 10 minutes. Meanwhile, heat the salsa. Pour the sauce over the turkey and sprinkle with cilantro.

Tips: To heat sauce in the NuWave, place sauce in an oven safe dish, place on liner pan or 1" rack and melt on power level HI for about 3 to 4 minutes.

(4 servings)

Caraway Duck with Raspberry Sauce 💡

- 2 legs, 2 thighs, 2 wings,
- 2 breasts cut in half
- 1 tablespoon crushed caraway seed
- salt & pepper to taste

Raspberry Sauce:

- 1 pint fresh raspberries
- 1 tablespoon lime juice
- ¼ teaspoon ground ginger
- cayenne red pepper to taste
- sugar to taste

Pierce the skin of each piece of chicken several times with a fork or knife. Season on both sides of the pieces and lay on the 1" rack, skin side up. Cook on power level HI for 30 minutes each side. While duck is baking, prepare the raspberry sauce.

Raspberry Sauce. Purée raspberries in a food processor or blender. With a flexible spatula, push the berries thru a pasta strainer to remove the seeds. Mix raspberry puree, lime juice, ginger and cayenne until well blended. Taste and add sugar as desired. Simmer sauce on low and be careful not to over cook the sauce. If you cook too long it will taste more like jam. Serve immediately with duck.

(2-3 servings)





TIPS FOR PORK

For even browning, turn pork halfway through the cooking process.

To use your favorite dry seasonings on frozen pork, sprinkle a little water on top of the pork and then add your seasonings. This will allow the seasonings to stick to the pork.

Brush sauces on fresh pork so the seasonings bake right in. To save time, marinate pork in a sealed bag or container and freeze into separate servings. When ready to use, refer to the cooking guide.

Place aluminum foil over the top to prevent the pork from browning too fast. Be sure to secure the aluminum foil to the sides of the rack or extend the aluminum foil outside the oven to prevent the NuWave Pro Infrared Oven's internal fan from moving the aluminum foil around during the cooking process.



To Cook a Ham: The NuWave® Pro Infrared Oven can cook up to an 8 lb. ham without the bone, and a 14 lb. ham with the NuWave® extender ring.

Place the ham on the 1" rack. For best results, flip the ham halfway through the cooking process. Add glaze during the last 5 minutes of cooking. Baste ham with the juices right in the liner pan. If browning too fast, place aluminum foil over the top. Cook 15 minutes per pound on power level 8.

** Using a meat thermometer is essential for checking the internal temperature of the meat.*

Adobo Cutlets

- 1 (4-6 ounce) pork cutlet
- 2 tablespoons white vinegar
- adobo seasoning
(available in Mexican food stores)
- chopped radishes for garnish

Place the cutlet in a shallow dish and season with adobo mixed with the vinegar. Place the dish on the 4" rack and cook on power level HI for 15 minutes or until juices run clear. Sprinkle with radishes and serve.

(1 serving)

Pork in Mole Sauce

- 1 (4-6 ounce) pork chop or cutlet
- 2 tablespoons mole sauce
- 2 tablespoons sesame seeds

*Mole sauce is available in Mexican food stores and provides an interesting taste to pork and chicken recipes. Spread the sauce over the surface of the pork and sprinkle on the seeds. Place on the 4" rack and cook on power level HI for 10 minutes, turn over and cook for another 5 minutes or until juices run clear.

(1 serving)

Baked Ham in Cola

- This Southern style ham has become very popular in the last 20 years.

- 10 lb. ham with bone in.
- 1 can cola
- 1 cup brown sugar
- 2 teaspoon dry mustard
- 1 teaspoon freshly ground pepper
- 1½ cup bread crumbs, plain

Place the ham on the 1" rack, fat side down. Add half can of cola to cover the ham. Cook on power level HI for 15 minutes per pound; frozen ham 20 minutes per pound. Baste the ham every 15 minutes. Remember to hit PAUSE before opening the oven and START to resume cooking. Mix brown sugar, mustard, pepper and bread crumbs together and add the mixture to the ham at the last 15 minutes of cooking. Pat down on the ham and add the rest of cola. Pour slowly. Bake the ham for 15 minutes. Let rest with the dome lid on for 5 minutes.

Tips: For the better flavor, use a ham with the bone. The bone can be also used to make soup.

Asian Marinated Pork Chops with Pineapple Relish

- Use a 1 to 1½" boneless or bone-in chop. This is an excellent recipe to freeze and pull out to cook in the NuWave. I also substitute chicken, shrimp and beef.

- 4 (1 to 1½" thick) pork chops
- 1 teaspoon ground ginger
- ¼ teaspoon black pepper
- ¼ cup soy sauce
- ¼ cup extra virgin olive oil
- 3 cloves chopped garlic
- 1 tablespoon brown sugar

Mix all ingredients in a freezer safe bag and marinate in your freezer or in your refrigerator for 2 hours. Place meat on 4" rack and cook on power level HI for 12 minutes per side for frozen.

(4 servings)

Tips: Cook time frozen: 12 minutes per side. Thawed: 6 to 7 minutes per side. Please keep in mind these are estimates and depending on the size and thickness cooking time may vary.

Pineapple Relish:

- 1 cup Fresh or canned pineapple (juice drained from can)
- ¼ cup sliced red onion
- 3 tablespoons chopped flat leaf parsley
- top with pineapple relish
- salt & pepper to taste



Glazed Spareribs 🍷💡

- 1 pork spareribs cut into pieces that will fit on the 4" rack
- 1 cup melted orange marmalade
- 2 teaspoons Dijon mustard
- 1 teaspoon lemon juice
- 1 tablespoon Worcestershire sauce
- season with salt and pepper

Melt marmalade and add mustard, lemon juice and Worcestershire sauce. Baste ribs. Place on the 4" rack and cook on power level HI for 15 minutes per side (frozen is 25 minutes per side). Let the meat sit under the dome for 5 minutes.

(4 servings)

Tips: Place your bake potatoes on the 2" rack* while cooking your ribs. Medium potatoes will be done when ribs are done.



*If you don't have a 2" rack, it's available on our website: www.nuwaveoven.net.

Chilled Pork Chops 🍷

- 4 loin pork chops (1")
- 6 tablespoons extra virgin olive oil
- 2 cloves garlic, minced
- 1 teaspoon oregano
- 1 teaspoon cumin
- 1½ teaspoon salt
- 2 tablespoons chili powder
- 2 tablespoons green chilies
- 2 tablespoons fresh cilantro

Place oil and all herbs and seasonings into a bowl and mix. If you are freezing, do in plastic freezer bag. Place pork chops in mixture and for 1 hour or overnight. Place chops on your 4" rack and cook on power level HI for 5 to 6 minutes per side if thawed (10 to 12 minutes per side if frozen. Keep in mind these are estimates). When juices run clear the pork chops are cooked. Let meat rest for 5 minutes before cutting. Potatoes or vegetables are recommended as a side dish.

(4 servings)

Italian Sausage with Peppers

- 4 ounces Italian sausage
- 1 red bell pepper, cored and sliced
- 3 scallions, cut into 1" pieces
- 2 cloves garlic, minced
- 1 tablespoon olive oil

Place everything in a shallow oven safe dish and set on the 4" rack. Cook on power level HI for 5 minutes. Turn the sausage over and cook an additional 5 minutes.

(1 serving)

Thai Pork Tenderloin 🍷

- *An easy preparation for tender full-flavored tenderloin. Marinate a few of these and have ready in the freezer for a quick easy meal. Serve with broccoli and stir-fried rice. This makes wonderful leftovers for sandwiches. For a less spicy version, use 1 tablespoon of Asian chili sauce.*

- 2 each pork tenderloins (about 12 ounce each)
- 2 cloves garlic, minced
- 1 tablespoon chopped gingerroot (1 teaspoon dry gingerroot)
- 2 tablespoons chopped fresh cilantro
- 3 tablespoons Hoisin sauce
- 2 tablespoons lime or lemon juice
- 1 tablespoon soy sauce
- 1 tablespoon sesame oil
- 2 tablespoons sweet Asian chili sauce

In a small bowl, combine garlic, ginger, cilantro, Hoisin, lime juice, soy sauce, sesame oil, and chili sauce. Arrange the tenderloins in a single layer in a dish just large enough to hold the tenderloins. Pour over the meat, turning to coat. Cover and refrigerate for 1 to 4 hours. If you are freezing, do in a plastic freezer bag. Place tenderloins on your 4" rack and cook on power level HI for 12 minutes per side if thawed, cook 18 to 22 minutes per side if frozen (keep in mind these are estimates). When juices run clear the tenderloin is cooked (internal temperature of 170 degrees F). Let meat rest for 5 minutes for cutting. Slice meat on the diagonal.

(6 servings)

Pork Chops with Mustard Sauce

- 2 tablespoons butter
- 1 tablespoon prepared mustard
- 1 tablespoon cream
- ½ teaspoon dried tarragon
- 1 (4-6 ounce) pork chop
- salt & pepper to taste

Mix the first five ingredients and spread over the surface of the pork. Place the chop in a shallow dish and cook on power level HI on the 4" rack for 15 minutes or until juices run clear.

(1 serving)

Kielbasa Casserole with Rice and Vegetables

- 1 can (10¾ ounce) condensed cream of celery soup, undiluted
- ¾ cup water
- 1 tablespoon butter or margarine
- 1½ cups instant rice
- 1 lb. sausage, sliced into ½" pieces
- 1 (10 ounce) package frozen peas, thawed
- 1 (10 ounce) package frozen corn, thawed
- 1 (4 ounce) cup shredded Cheddar cheese

In a medium saucepan, combine soup, water, and butter. Bring to a boil, mixing until smooth. Stir rice into the soup mixture, cover and let stand 5 minutes. Stir in sausage, peas, and corn. Place rice mixture in oven safe dish to fit into the NuWave. Place dish on liner pan and cook on power level HI for 20 minutes. Top with cheese and cook 1 to 2 minutes more or until cheese melts.

(4-6 servings)



TIPS FOR SEAFOOD

Place fish fillets pretty side down, flipping halfway through cooking time.

To use your favorite dry seasonings on frozen fish, sprinkle a little water on top of the fish and then add your seasonings. This will allow the seasonings to stick to the fish.

To steam fish, place aluminum foil over the top of the fish. Be sure to secure the aluminum foil to the sides of the rack or extend the aluminum foil outside the oven to prevent the NuWave® Pro Infrared Oven's internal fan from moving the aluminum foil around during the cooking process.

Place lemons on the 4" rack and heat on power level HI for 2 to 3 minutes to get the most lemon juice.

Melt butter on power level HI for 4 to 6 minutes.



Steaming Recommendations

Whole Fish

Flesh should be opaque and almost ready to flake

Shrimp

Flesh turns opaque and outside shell turns pink to red

Scallops

Flesh turns opaque

Lobster Tails

Flesh turns opaque and outside shell turns to red

** Using a meat thermometer is essential for checking the internal temperature of the meat.*

Artichoke Topped Tilapia

- 4 (6-8 ounce) tilapia filets, rinsed
- 2 tablespoons olive oil
- 1 tablespoon Italian herb seasoning
- 1 teaspoon soy sauce
- 1 cup prepared artichoke antipasto from jar, drained
- ½ cup grated Parmesan cheese
- 8 pieces of parchment paper; same size of each tilapia filet

Place each tilapia filet on a piece of parchment paper. Set the remainder of parchment papers aside. Mix together the olive oil, Italian herb seasoning and soy sauce. Brush the exposed side of each filet with the olive oil mixture and place on 4" rack. Cook on power level HI for 7 minutes. Place the remaining parchment sheets over each filet and turn over each filet on the rack and discard the original 4 pieces of parchment paper. Cook on power level HI for 3 minutes more or until fish is just barely cooked. Mix the artichoke topping with the cheese. Divide this mixture in an even layer over each filet. Cook on power level HI for 2 minutes more. Serve filets on parchment paper.

(4 servings)

Snapper with a Snap

- 4 red snapper filets, about 1½ lbs.
- 4 cloves garlic, minced
- ½ teaspoon dried pepper flakes
- 1 teaspoon olive oil
- 1 teaspoon ground cumin
- juice of 1 lemon
- chopped cilantro

Place fish in single layer in shallow pan. Mix other ingredients except cilantro and pour over fish. Place dish on 4" rack and NuWave on power level HI for 10 to 12 minutes. Sprinkle with cilantro and serve.

Frozen: Cook 16 to 18 minutes

(4 servings)

Ancho Chili Crusted Salmon Tacos

- 24 ounces salmon filets
- 1 tablespoon canola oil
- 1 teaspoon ground ancho chili powder
- 1 tablespoon cumin
- 2 tablespoons brown sugar
- 1 teaspoon soy sauce
- 6 ounces shredded cabbage
- ½ cup jalapeno ranch dressing
- 8 to 12 corn tortillas

Rinse the salmon filets and drain on paper towel. Brush with the oil on both sides. Place salmon on parchment paper skin side up on 4" rack. Cook for 5 minutes on power level HI. Meanwhile stir together the chili powder, cumin and brown sugar. Turn the salmon when the 5 minutes are up and drizzle the soy sauce over the top. Sprinkle the brown sugar mixture over the top of the salmon. Cook on power level HI to desired doneness, about 8 to 10 minutes more. While the salmon is cooking, toss together the cabbage and the dressing. Warm the tortillas wrapped in foil in the bottom of the oven for the last 5 minutes while the salmon cooks. Serve the salmon with the warm tortillas and cabbage mixture.

(4 servings)

Bass with Fennel

- 6 ounces stripped or black bass, (1" thick)
- 1 teaspoon fennel seeds, crushed
- 1 tablespoon olive oil
- 1 tablespoon lemon juice
- salt & pepper to taste

Mix the ingredients except the fish. Place the fish on the 4" rack and spread on the fennel mixture. Cook on power level HI for 8 minutes.

(1 serving)

Tuna with Fresh Orange Salsa 🍴

- A penetrating, earthy cumin rub on the tuna perfectly complements the vibrant, orange and walnut salsa.

- 4 fresh or frozen tuna steaks, rinse steaks and pat dry
- 1 teaspoon orange peel, finely shredded
- 4 medium oranges, peeled, sectioned, and coarsely chopped
- 1 large tomato, seeded and chopped
- ¼ cup snipped fresh cilantro
- 2 tablespoons green onion, chopped
- 2 tablespoons walnuts, chopped
- 1 tablespoon lime juice
- ½ teaspoon ground cumin
- 1 tablespoon olive oil

In a small bowl combine cumin, ½ teaspoon of salt, and ¼ teaspoon black pepper. Brush fish with olive oil and sprinkle with cumin mixture. Place fish on the 4" rack and cook on power level HI for 4 to 5 minutes per side (if fish is thicker or thinner than an inch, refer to the Quick and Easy Cooking Guide). Fish should fork easily when tested. Spoon salsa over the fish, and serve.

(4 servings)

Salsa:

In a medium bowl combine the orange peel, chopped oranges, tomato, cilantro, green onion, walnuts, lime juice, ¼ teaspoon salt, and ¼ teaspoon black pepper. Set aside.

Nutrition facts per serving:

262 calories, 12g total fat, 2g saturated fat, 43mg cholesterol, 343mg sodium, 11g carbohydrates, 3g dietary fiber, 28g protein.

Peppered Tuna with Hoisin Sauce 🍴💡

- I love cooking with these Asian flavors. Serve as a dinner or top Wonton crisps with a slice of this tuna and a dollop of Hoisin sauce and serve on a platter as an elegant party snack.

- 4 each 5-6 ounce pieces of tuna (½" pieces)
- 1 teaspoon Szechuan
- 1 teaspoon peppercorns, crushed
- 1 teaspoon black pepper, crushed
- 2 tablespoons soy sauce
- 3 tablespoons sesame oil
- 1 tablespoon lemon juice
- mix the above spices and spread over tuna

Hoisin Sauce:

- 2 tablespoons soy sauce
- 2 tablespoons Hoisin Sauce
- 1 tablespoon honey or molasses
- 1 clove garlic, minced
- 2 tablespoons fresh lime Juice
- ½ teaspoon grated fresh ginger
- ½ teaspoon chili paste, or more to taste
- 2 tablespoons peanut oil or sesame oil

(4 servings)

In a small bowl mix ingredients in a small bowl for dipping sauce. Place tuna pieces on the 4" rack that have been spread with the oil and pepper mixture. Cook on power level HI for 4 minutes per side (if you use thicker pieces (1") it's 5 to 6 minutes per side). Place the Hoisin sauce in a small dipping bowl.

Tips: I love asparagus with this meal. Just coat them with extra virgin olive oil and sprinkle kosher salt. Place them on the 4" rack and cook on power level HI for 3 minutes (if asparagus are thicker, add an extra minute).

Cheesy Crab Melts 🍴

- This recipe can use canned tuna and is great as a sandwich. Having lived in New Orleans for 20 plus years, I always use jumbo lump crab meat. I became spoiled! You may use whatever kind of crab you want.

- 7 ounces jumbo lump crab meat
- ½ cup shredded Cheddar, Brie or Asiago cheese
- ¼ cup celery, finely chopped
- ¼ cup red bell pepper, finely chopped
- ¼ cup green onion, finely chopped
- ¼ cup mayonnaise
- 1 teaspoon Russian-style mustard or Dijon
- ½ teaspoon salt
- ¼ teaspoon black pepper
- 3 English muffins

Pick through crab to make sure there are no shells. If using crab meat that has any liquid, please squeeze out any extra liquid. Combine all other ingredients except English muffins. Gently fold all together. Cut English muffins in half horizontally. Place on the 4" rack. Spread crab mixture evenly over muffins. Bake on power level HI for 5 to 6 minutes, or until cheese is bubbly.

(6 pieces)

Sweet Chili Scallops

- 16 to 18 ounces sea scallops
- ⅓ cup olive oil
- 1 tablespoon soy sauce
- 1 tablespoon sweet chili powder
- 1 tablespoon ground cumin

Rinse the scallops and drain on paper towel. Mix together the olive oil, soy sauce, chili powder and cumin. Just prior to cooking, toss the scallops in the marinade. Place the scallops on 4" rack. Cook for 4 minutes on power level HI, turn the scallops and cook 3 more minutes on power level HI, or to desired doneness.

(4 servings)

Simple Sole ♥

- 1 (5 ounce) filet of sole
- 1 tablespoon lemon juice
- 2 tablespoons butter
- salt & pepper to taste

Place the fish in a shallow dish and add the other ingredients. Place on the 4" rack and cook on power level HI for 5 minutes.

(1 serving)

Shrimp in Spiced Beer ☺

- 1 lb** shrimp
- 4 cloves garlic, minced
- 1 cup beer
- 1 tablespoon Old Bay® seasoning

Place everything in an oven safe dish and place on 4" rack. Cook on power level HI for 8 minutes (frozen: 12 minutes).

**Cooking time may vary depending on size of shrimp. Large Shrimp: Peel and de-vein. Serve hot or cold. Small 'peel and eat' shrimp: leave shell on and serve.

(4 servings)



Shrimp with Lemon ♥

- 12 large shrimp, peeled and deveined
- juice on half lemon
- 2 tablespoons olive oil
- 1 teaspoon lemon pepper

Place everything in a shallow bowl and set on the 4" rack. Cook on power level HI for 6 minutes, stirring halfway.

(2 servings)

Shrimp Dijon Chef Jennifer's Style 🍴

- This recipe is done in the 12" liner pan and cooked on the 1" rack. I make this a day ahead if I'm having people over. It freezes great! I serve this as an entrée over rice, and as an appetizer with bread rounds or crackers. This recipe has a lot of garlic, so if you don't want that much garlic scale back. Here's a tip; if you open up the garlic bulb and it smells very strong cut back, the same goes for onions. I was taught to cook with my senses. Enjoy!

- 2 lbs. 21/25 peeled and de-veined shrimp (the below needs to be brought to a boil in saucepan or stove top)
- 5-6 cloves garlic, chopped
- 2 sticks butter
- 1 cup dry white wine
- ¼ fresh parsley, chopped
- 1 lemon, juiced
- black pepper to taste
- 1¾ Italian bread crumbs

Wash and peel and de-vein shrimp. Pat dry and place in the 12" liner pan (use already peeled and de-veined shrimp to save time). In a sauce pot, add garlic, butter, wine, parsley, lemon, and pepper. Bring to one quick boil. Reduce and simmer for 5 minutes. Remove from the heat and add bread crumbs. Mix well. Place crumb mixture on top of the shrimp. Place on the 1" rack and cook for 20 minutes on power level HI. Check for salt and add as needed.

(6 servings for dinner or 12 servings for appetizer)

Tips: When adding salt, use salted butter for better flavor. Asparagus is a good side dish.

Lemon Salmon with a Mango Salsa 🍴❤️

- This is a perfect for a quick weeknight meal. Papaya or pineapple can be used in place of mango.

- 4-6 ounces salmon fillets
- 2 tablespoons lemon juice
- 1 tablespoon olive oil
- 1 tablespoon grated lemon zest
- 2 teaspoon Dijon mustard
- ½ teaspoon black pepper

In a small bowl, whisk together lemon juice, olive oil, lemon zest, mustard and pepper. Place fish in a baking dish and pour marinade over fish. Marinate refrigerated for 20 minutes. While fish is marinating prepare salsa.

Mango Salsa:

- 1 ripe and peeled mango, diced
- 2 green onions, finely chopped
- ¼ cup red bell pepper, chopped
- 2 tablespoons fresh cilantro, chopped
- 2 tablespoons lime juice

Place salmon on the 4" rack and cook on power level HI for 5 to 6 minutes per side (cook time may vary depending on the size of the fillet. About 1" thick are recommended). Place mango salsa over the salmon and Enjoy.

(4 servings)



Lobster Tail with Crawfish Meat 🍴

- 1 (4-6 ounce) lobster tail, removed from shell and cut into 1" pieces
- 3 ounces crawfish
- 2 tablespoons butter
- 2 tablespoons dry Sherry
- 2 tablespoons grated Parmesan cheese

If cooked while frozen, cook for 5 minutes before adding other ingredients. Mix everything in a shallow dish and place on the 4" rack. Cook on power level HI for 10 minutes, stirring once.

(1 serving)



Lobster Thermidor 🍴

- 1 (4-6 ounce) lobster tail, removed from shell and cut into 1" pieces
- 2 tablespoons butter
- 2 tablespoons heavy cream
- 2 tablespoons minced shallot
- ½ teaspoon dry mustard
- chopped parsley

Mix everything in a shallow dish and place on the 4" rack. Cook on power level HI for 10 minutes, stirring once.

(1 serving)

Clams & Sausage

- 1 sausage, crumbled
- 8 littleneck clams or 1 can (8 ounces) whole clams
- 1 clove garlic, minced
- chopped cilantro
- lemon slices
- Tabasco sauce to taste

Scrub the clams in the shell and mix with the other ingredients except the lemon slices in a shallow bowl. Place on the 4" rack and cook on power level HI for 10 minutes or until the clams open and the sausage is cooked. Serve with the lemon slices.

(1 serving)

Shellfish Medley ❤️

- 4 littleneck clams
- 4 large shrimp
- 4 mussels
- 2 squid, cleaned and cut into 1" rings
- 2 cloves garlic, minced
- 2 tablespoons olive oil
- ¼ cup clam juice
- 1 tablespoon hot sauce
- dash of minced parsley

Scrub the clams and mussels. Mix everything in a pie plate and place on the 4" rack. Cook on power level HI for 15 minutes or until the clams and mussels are opened.

(2 servings)

Grilled Calamari ❤️

- 4 medium squid, cleaned
- 2 tablespoons olive oil
- 2 tablespoons butter
- 1 teaspoon parsley, chopped
- salt & pepper to taste

Mix everything in a shallow dish and place on the 4" rack. Cook on power level HI for 10 minutes, stirring once. Sprinkle with parsley and serve.

(2 servings)



TIPS FOR VEGETARIAN DISHES

Egg substitutes may be used in place of raw eggs in all recipes.

To prepare rice, place appropriate amounts of rice, hot boiling water, butter and salt in a covered dish according to directions. Place the covered dish right on the liner pan. Cook on HI for around 30 minutes until tender. For extra flavor, add $\frac{1}{2}$ onion (finely chopped) to the rice mixture.

For instant rice, use twice the amount of instant rice that the recipe calls for. Put the instant rice in a pan, bring the recipe's amount of water to a boil, pour over the rice, cover and let stand for 5 minutes. Proceed with the recipe, figuring about 30 percent less cooking time than needed. Test for doneness in the center-bottom area of the rice. This rice is the last to be cooked.

For casseroles, place the casserole dish in an oven-safe dish, cover and place on the 1" rack. Cook for about 20 percent less time than the original recipe. If melting or broiling, simply take off the foil and bake for an additional 5 to 10 minutes depending on doneness and appearance.

Casseroles cook the best when they're less than 3" deep. If they need to be cooked more than 20 minutes, cover with aluminum foil to avoid over-browning.

TVP Note: Textured Vegetable Protein (TVP) is a soy product that comes in a variety of forms and flavors. It is high in protein and has little or no carbohydrates. For breading poultry, meat or vegetables, place the TVP in a food processor or blender and grind until fine. Add 2 tablespoons of butter to 1 cup of fine TVP and cook in the NuWave for 5 to 6 minutes or until crunchy. Refrigerate until used as breading, or simply sprinkle over recipes to give a crunchy texture. TVP also comes in small dice-sized chunks that can be used as croutons in salads and soups. Keep a supply on hand and replace bread crumbs, crackers, corn flakes or other high carbohydrate breading ingredients.



Stuffed Peppers with Barley

- 1 cup reduced-sodium chicken or vegetable broth
- 1 cup sliced fresh mushrooms
- $\frac{2}{3}$ cups quick-cooking barley
- 2 large red, yellow, or green peppers (about 1lb.)
- 1 egg, beaten
- $\frac{3}{4}$ cup shredded Mozzarella cheese
- 1 large tomato, peeled, seeded, and chopped
- $\frac{1}{2}$ cup shredded zucchini
- $\frac{1}{3}$ cup soft bread crumbs
- $\frac{1}{2}$ teaspoon dried basil, crushed
- $\frac{1}{8}$ teaspoon dried rosemary, crushed
- $\frac{1}{8}$ teaspoon onion salt
- several dashes bottled hot pepper sauce

In a medium saucepan combine the broth, mushrooms, and barley. Bring to boiling; reduce heat. Simmer, covered, for 12 to 15 minutes or until barley is tender. Drain thoroughly. Cut peppers in half lengthwise; remove seeds and membranes. In a medium mixing bowl stir together the egg, $\frac{1}{2}$ cup of the cheese, the tomato, zucchini, bread crumbs, basil, rosemary, onion salt, and bottled hot pepper sauce. Stir in cooked barley mixture. Place peppers, cut side up, on the 1" rack. Spoon barley mixture into the pepper halves. Cover and bake on power level HI for 15 to 20 minutes or until filling is heated through. Sprinkle remaining cheese over the peppers. Bake on power level HI uncovered for 2 to 3 minutes.

(4 servings)

Alternative:

Try eggplant as a substitute for the peppers.



Grilled Vegetable Quesadillas

- Colorful grilled vegetables and Pepper-Jack cheese make a lively and satisfying filling for these quesadillas.

- 8 flour tortillas (6")
- 1 small zucchini, sliced lengthwise into 4 slices
- 1 small yellow squash, sliced lengthwise into 4 slices
- 1 red bell pepper seeded and cut into 8 pieces
- 1 green bell pepper, seeded and cut into 8 pieces
- 1 small red onion cut into slices
- 2 cloves garlic, sliced
- 1 cup shredded Pepper-Jack cheese
- $\frac{1}{4}$ cup cilantro, chopped
- $\frac{1}{4}$ cup olive oil
- Kosher salt and black pepper to taste

Cut the vegetables and place in the bowl. Toss them with olive oil, salt and pepper. Spread on the 4" rack and cook on power level HI for 5 minutes. Turn vegetables and cook an additional 5 minutes. Remove. Arrange the vegetables on four of the flour tortillas. Top with cheese and cilantro and the remaining tortillas. Lightly spray the tortilla tops with non-stick cooking spray. Place two tortillas at a time on the 4" rack and cook for 3 minutes or until the cheese is melted. Cook the remaining two and serve with your favorite salsa.

(4 servings)

Tomato and Olive Tart 🍷❤

- One bite of this French tart and you'll feel like you're in Provence. All the flavors of the Mediterranean - tomatoes, shallots, olives, fennel, thyme, and garlic - top sheets of flakey phyllo dough. I use plum tomatoes, because they are firm, meaty, and hold up well in cooking.

- 3 Plum tomatoes, thinly sliced
- 15 small oil-cured black olives, pitted and chopped
- 1 large shallot, minced
- 1 tablespoon thyme, minced or 1 teaspoon dried
- 1 tablespoon fennel seeds, finely crushed
- 1 tablespoon olive oil
- 4 (12" x 17") sheets phyllo (at room temperature)
- ½ cup shredded Havarti cheese
- ¼ cup basil, chopped

Place tomato slices on 2-3 layers of paper towels. Cover with more paper towels and blot gently. Let stand for 10 minutes. Combine the olives, shallot, thyme, fennel, and olive oil in a small bowl. Spray the 10" baking pan with non-stick spray, or use an 8" x 8" square pan sprayed. Lay one layer of Phyllo dough in pan and spray with olive oil. Repeat for the next three layers. Roll the edges of the phyllo in to make a rim and spray olive oil. Arrange the tomatoes across the phyllo. Sprinkle the olive mixture on top of the tomatoes evenly. Bake on the 1" rack and cook on power level HI for 10 minutes or until the edges become brown and tomatoes are soft. Sprinkle the cheese over tart and bake for 2 more minutes on power level HI. Remove and add basil. Cut tart into 6 pieces. Serve hot.

Tofu Teriyaki

- 12 ounces super firm tofu
- ¼ cup each of honey & soy sauce
- 1 teaspoon ginger powder
- hot sauce of choice, to taste
- 1 clove fresh minced garlic
- 1 tablespoon sesame oil
- 3 drops liquid smoke

Slice the tofu like a loaf of bread in about ¾" thick slices. Place the slices in a single layer on paper towel to drain. Mix together the honey, soy sauce, ginger, hot sauce, garlic, sesame oil and liquid smoke. Brush the tops of the tofu slices with the marinade. Place brushed side down on the 4" rack. Brush the tops of the slices with the marinade. Cook on power level HI for 10 minutes, turn the slices, brush again with the marinade and cook on power level HI for an additional 10 minutes.

(4-6 servings)

Taco Pie

- 2 cups prepared mashed potatoes, cooled
- 4 veggie burgers
- 1 cup salsa
- 1½ cups Mexican blend shredded cheese

Frost the inside of a 8" or 9" pie dish with the potatoes. Crumble the veggie burgers evenly over the bottom. Spoon the salsa evenly over the crumbled burgers. Sprinkle the cheese over that. Tent the dish with foil and cook on 4" rack on power level HI for 7 minutes. Remove the foil tent and cook on power level HI 3 to 5 minutes longer, until cheese is bubbling and golden brown.

(4-6 servings)

Ricotta Spinach Rolls

- 8 lasagna noodles, cooked and drained

Sauce:

- 1 medium onion, finely chopped
- 2 cloves garlic, minced
- 1 tablespoon butter
- 3 cups tomato sauce
- 1 teaspoon oregano
- ½ teaspoon thyme leaves
- ½ teaspoon basil
- ¼ cup chopped mushrooms (optional)

Filling:

- 1 (10 ounce) package frozen chopped spinach
- 1 cup Ricotta or Cottage cheese
- 2 tablespoons Parmesan cheese
- dash pepper

To prepare the Sauce:

Saute onion and garlic in butter until vegetables are tender. Add tomato sauce, seasonings, mushrooms, and simmer.

Cook spinach according to package directions. Drain and squeeze out excess water. Blend together spinach, cheeses and pepper. Spread mixture evenly along entire length of each noodle. Roll each one and place on its side in the liner pan lightly greased. Cover with sauce. Bake in NuWave on power level HI for 15 minutes or until heated through.

(4-6 servings)

Summer Fresh Peppers with Fresh Herbs and Tomatoes 🍷❤

- I love the freshness and the simple ease of this dish. If you have a garden full of peppers, make these and freeze and pull out in January and start counting the days until we will be out in our gardens again, too.

- 3 red or yellow bell peppers, halved lengthwise and seeded
- 3 medium tomatoes, cored and cut in wedges
- 1 tablespoon capers
- 3 cloves of garlic, thinly sliced
- ¼ cup fresh basil, shredded
- ½ cup dry bread crumbs
- ½ teaspoon salt
- ¼ teaspoon black pepper
- 2 tablespoons olive oil

Arrange peppers cut side up in a single layer on the 4" rack. Place tomatoes, capers and garlic in pepper cavities. Sprinkle with basil, bread crumbs, salt and pepper. Drizzle olive oil over top. Cook in your Nuwave oven on power level HI for 20 minutes. Keep in mind the cooking time could be a couple minutes more or less depending on the size of the peppers.

(6 servings)



TIPS FOR DESSERTS



Cookies can be baked right in your liner pan, and you can use the rack as a cooling rack. Depending on the cookie's size, place about 10 to 12 cookies directly on the liner pan. Bake on power level HI for 9 to 12 minutes. Remove dome and let the cookies rest on the liner pan for about 2 minutes. Place them on the rack to finish cooling.

For bottom crust pies, bake the crust only for 15 to 20 minutes. Add the pie filling and cook remaining time as directed.

If any desserts begin to brown too fast, place aluminum foil over the top. Be sure to secure the aluminum foil to the sides of the rack or extend the aluminum foil outside the oven to prevent the NuWave® Pro Infrared Oven's internal fan from moving the aluminum foil around during the cooking process.

If the recipe calls for a glaze, place it on the last 5 minutes of cooking time to prevent overcooking. For better results with desserts and breads, reduce to power level 8. Place the dish on the 1" rack. Use the original directions instead of decreasing the time by 20 percent.

Cinnamon Pecan Bites

- 2/3 cup milk
- 2 tablespoons cream
- 4 tablespoons unsalted butter, melted
- 1 cup brown sugar
- 1 small tube refrigerator cinnamon roll dough
- 1/2 cup chopped pecans

Mix together the milk, cream, butter and sugar and place in a 9" cake pan. Place pan on the 1" rack and cook on power level HI for 4 minutes. Cut the cinnamon rolls into quarters and distribute the pieces in the warm caramel in the pan leaving space in between each piece. Cook on power level HI for 10 minutes. Sprinkle the pecans over the pan and cook an additional 3 to 5 minutes. Serve warm.

(8 servings)

Pound Cake 🍷

- *This recipe comes from a friend of mine from Richland Parish, Louisiana. Pair this cake with strawberries in season and fresh whip cream and it's heaven.*

- 8 eggs, separated
- 6 tablespoons sugar
- 1 lb. butter or margarine
- 3 1/2 cups all purpose flour
- 1/2 cup light cream
- 2 1/2 cups sugar
- 1 tablespoon vanilla

Separate eggs and beat the egg whites until stiff with 6 tablespoons sugar. Set aside. Beat egg yolks in a separate bowl. Cream margarine and 2 1/2 cups sugar until well mixed. Add egg yolks that have been beaten. Add flour and cream alternately into the egg yolk mixture. Add vanilla. Fold in stiffly beaten egg whites. Bake in a large bread pan (4" x 8") that's been well greased and floured. Bake on 1" rack on power level HI for 60 to 65 minutes. Check with a toothpick for doneness. Let cool in pan for 10 minutes before removing from pan. (6 servings)

Tips: Slice some of your favorite fruits or eat plain. As I mentioned above, in season strawberries are the way to go. I whip 1 cup of whipping cream with a little sugar and beat on high until fluffy in cold metal bowl. The trick to good whip cream is no liquid in the bowl and clean beaters.

Apple Crisp 🍷

- 4 apples peeled, cored, and sliced 1/8" thick
- 1/2 cup flour
- 1/2 cup brown sugar, firmly packed
- 1/2 cup quick cooking oatmeal
- 1/4 cup butter, softened
- 1/4 cup granulated sugar
- 3/4 teaspoon cinnamon

Grease an 9" round cake pan. Place sliced apples in the pan. In a medium bowl, combine flour, brown sugar, oatmeal, and softened butter until well mixed. Set aside. In a small dish mix granulated sugar and cinnamon. Sprinkle over the apples. Pat the oatmeal mixture on top. Place on the 1" rack and cook on power level 6 for 47 minutes or until apples are tender and juices are bubbly.

(8 servings)



Baked Apples 🍏

- 4 medium apples (Honey Crisp, Washington, Gala, Golden Delicious-use any of your favorite apples)
- ¼ cup maple syrup
- ¼ cup apricot jam or your favorite jam
- ¼ cup apple juice or water
- 2 tablespoons lemon juice
- ¼ teaspoon ground nutmeg

Core apples using an apple corer or melon ball scoop. Using a sharp knife, score and peel about a third of the way down the apples (this prevents the apples from bursting). Arrange the apples in a 10" baking pan. In a small bowl combine all of the rest of the ingredients and mix. Spoon into the center of the apples, letting the remainder drizzle over. Place on the 4" rack and bake on power level HI for 15 minutes. Let cool for 5 minutes. The jelly will be very hot. Check to make sure the apples are tender (cooking times vary depending on the size of apples).

Jen's Brownies 🍫

- 4 squares unsweetened chocolate
- 4 large eggs
- ½ lb. butter or margarine (2 sticks)
- 2 cups sugar
- 1 teaspoon vanilla
- 1 cup sifted flour
- ¼ teaspoon salt
- 2 cups pecans, chopped

Melt chocolate with butter or margarine in a small saucepan. Beat eggs well in a large mixer bowl; gradually beat in sugar until mixture is fluffy and thick (this takes 10 minutes in an electric mixer). Stir vanilla into chocolate mixture and then fold in flour, salt, and nuts until blended. Pour into two 10" greased baking pans. Place baking pan on 1" rack and bake 1st cake on power level HI for 20 minutes. Brownies should be fudge like in the middle. For 8" x 8" pan, bake for 22 minutes on power level HI. Cut rounds into pie cuts. Add some powdered sugar and whipped cream and enjoy!

Lemon Drizzle Coffee Cake 🍰

- 4 tablespoons butter
- 1 cup sugar
- juice from 3 fresh lemons
- 1 teaspoon pure vanilla extract
- 8 unbaked refrigerator biscuits
- powdered sugar for dusting

In a small saucepan over medium heat, stir together the butter, sugar, lemon juice and vanilla until butter and sugar melt. Keep warm. Place ½ of the warm syrup in the bottom of a 9" cake pan and place on 1" rack. Carefully pull apart four biscuits and layer the eight split biscuit pieces in the syrup. Pour another ⅓ of the syrup over the biscuit pieces. Bake on power level 8 for 10 to 12 minutes. Pull apart the remaining biscuits into halves and place over the baked biscuits in the pan. Pour the remaining syrup over that and bake on power level 8 for an additional 10 to 12 minutes. Dust with powdered sugar and serve warm. (8 servings)

English Toffee Bars 🍪

- 2 cups flour
- ¾ cup granulated sugar
- ¾ cup butter, softened
- 1 large egg
- 1 teaspoon baking soda
- 1 teaspoon vanilla
- 1 (8 ounce) package of milk chocolate toffee bits

Mix all the ingredients together in a medium bowl until well blended. Divide the dough in half (about 1½ cups). Give the baking pan a quick spray of oil. Gently pat the dough in baking pan. Place on 1" rack and bake on power level HI. Before they cool completely, cut into bars.

For crunchy bars:

Bake for 20 minutes.

For chewier bars:

Bake for 15 minutes.

(Makes two 10" baking pan)

Lemon Squares 🍰

- 1 cup flour
- ½ cup butter, softened
- ¼ cup powdered sugar
- 2 large eggs
- ⅔ cup granulated sugar
- ½ teaspoon baking powder
- ¼ teaspoon salt
- 2 tablespoons freshly squeezed lemon juice

In a medium bowl, blend together the flour, butter and powdered sugar. Press evenly in an 8" x 8" glass pan. Place on 1" rack and bake on power level HI for 20 minutes. Meanwhile, mix together the eggs, sugar, baking powder, salt, and freshly squeezed lemon juice. Pour on top of crust. Cover pan with foil, securing the edges to prevent foil from coming off. Bake on HI for 13 minutes. Make a hole in the center of the foil and peel back a bit. Bake on HI for 8 minutes. Take off foil and bake for an additional 4 minutes. Cool completely before cutting into 16 squares. Sprinkle with powdered sugar. (8 servings)

(8 servings)



Right Side Up, Upside Down, Pineapple Cake

- 1 package yellow cake mix
- 1 (15 ounce) can pineapple rings
- ½ cup brown sugar

Mix cake as directed and fill 9" pie dish with batter. (You will have enough left over to make three cupcakes). Place on the 4" rack, cover with parchment paper and bake on power level HI for 20 minutes. Uncover, Lay pineapple over the top and cut some of the remaining rings to fit the gaps. Sprinkle the brown sugar evenly over the top and continue cooking another 20 minutes or until cake is set and sugar has caramelized.

(8 servings)



Nana's Shortbread Cookies

- My Nana was a wonderful baker. She always taught me to bake with real butter. If you're going to indulge in sweets you might as well use the real butter. As I stated all along I'm a Chef not a baker, but I always have butter on hand for those times I'm forced to bake. Baking, unlike cooking is an exact science. Therefore you have to measure everything. I cut the 10" baking pan in pie shape cookies. Reminds me of the old fashion tea biscuits.

- 1 cup un-salted butter
- ½ cup Confectioner's sugar
- ¼ teaspoon salt
- 2 cups sifted flour
- ¼ teaspoon baking powder

Cream butter until soft. Add sugar gradually and cream. Add dry ingredients and mix thoroughly. Pat into the pan size you are using. Bake at power level HI for 20 minutes for the 10" baking pan on the 1" rack. Bake at power level HI for 25 minutes for the 8" x 8" pan on the 1" rack. While still warm, sprinkle with powdered sugar.

(Makes one 10" baking pan or one 8" x 8" pan of shortbread)

Caramelized Pineapple Sundaes

- 4 (1" thick) slices fresh pineapple, trimmed leaving in the core
- ½ cup brown sugar
- ½ teaspoon cinnamon
- 2 tablespoons heavy cream
- 4 scoops vanilla bean ice cream or vanilla frozen yogurt
- 1 cup hot fudge sauce, warmed

Place the pineapple on the 4" rack. Sprinkle the tops of each slice with sugar and cinnamon. Drizzle a little cream over the tops. Cook on power level HI for 4 to 5 minutes or until sugar bubbles and turns golden. Place the pineapple slices on serving dishes and top with ice cream and warm fudge sauce.

(4 servings)

Bread Pudding with a Whiskey Sauce

- 10 slices white bread (day old)
- 4 tablespoons white sugar
- 3½ cups milk
- 4 eggs, separated
- 1 tablespoon vanilla
- 1 tablespoon salt
- 2 sticks butter
- 1 cup raisins

Break bread into the oven safe casserole dish, no bigger than 1½ qt. Soften bread with small amount of milk. Beat sugar and egg yolks. Add milk and stir well. Add vanilla and salt. Pour milk mixture over the bread. Fold in raisins. Cut butter into chunks and fold in. Place pan of bread pudding in 1" rack and bake on power level HI for 30 minutes. Check by sticking knife in center, if it comes out clean it's done.

Whiskey Sauce:

- ½ cup sugar
- ¼ cup water
- ¼ cup butter
- 1 shot glass Whiskey

Mix all the ingredients and cook until dissolved. Remove from heat and add whiskey to individual taste.

(6 servings)



Almond Tart

- 10-12 ounces ginger snaps, broken into pieces
- 1 stick unsalted butter, cut into pieces
- 12 ounces chopped almonds
- 4 eggs
- ¾ cup light corn syrup
- ¼ cup honey
- ½ cup sugar
- 1 tablespoon rum
- 1 teaspoon pure vanilla extract
- dash of salt

Process the cookie pieces and butter pieces together in the bowl of a food processor fitted with a steel blade until the crumbs begin to soften together. Press into a 9" tart pan, along the sides and bottom. Sprinkle the almonds evenly over the bottom of the crust. Beat together the eggs, corn syrup and honey until pale in color. Beat in the sugar, rum, vanilla and salt. Pour over the almonds and bake on 1" rack on power level HI for 5 minutes. Tent the tart with foil and bake on power level 8 for 30 minutes. Remove the foil tent and bake on power level 8 for an additional 15 minutes. Serve warm with sweetened whipped topping if desired.

(8 servings)

Top Crust Only Pies

- 1 (20 ounce) can apple, cherry, or blueberry pie filling
- 1 package refrigerated pie crust
- vanilla ice cream or whipped cream for topping

Put pie filling in an 8" pie plate and flute the edges. Place on 4" rack. Bake on power level HI for 20 minutes or until crust is browned. To serve, cut top crust with a knife and scoop out the crust and filling into individual plates or bowls. Top with cream.

(8 servings)

Easy Low-Fat Apple Pie

- 2 medium Golden Delicious or Granny Smith apples
- 1 low-fat Graham cracker crust
- 2 teaspoons Splenda® substitute
- 1 teaspoon cinnamon
- spray butter
- 1 can apple juice concentrate, thawed
- 2 tablespoons cornstarch
- 5 sheets low-fat Graham crackers

Peel and core apples and slice thin. Layer onto Graham cracker crust in 3 layers, sprinkling cinnamon, Splenda® and butter spray between each layer. In plastic bag, break up Graham cracker sheets in small pieces (do not crush fine) and cover apples. Thaw apple juice in 2 cup measuring cup, add cornstarch, mix well. Pour over the top of the pie slowly, moistening crackers, and filling shell to edge. Place on 1" rack, dome with tin foil (securing 4 corners so does not blow around but allowing for heat to pass through). Bake on power level HI for 25 minutes, remove foil, and continue another 20 minutes until done (total bake time about 45 minutes).

(8 servings)



Easy Low-Fat Cherry Pie

- 1 large can bing cherries (in water if possible)
- 1 low-fat Graham cracker crust
- 2 teaspoons Splenda® substitute
- 1 teaspoon cinnamon
- spray butter
- 1 can apple juice concentrate, thawed
- 2 tablespoons cornstarch
- 5 sheets low-fat Graham crackers

Drain water or syrup out of cherries, but do not crush the cherries. Pour into Graham cracker crust. Sprinkle cherries with Splenda® and cinnamon, and spray with butter spray. In plastic bag, break up Graham cracker sheets in small pieces (do not crush fine) and cover cherries. Thaw apple juice in 2 cup measuring cup, add cornstarch, mix well. Pour over the top of the pie slowly, moistening crackers, and filling shell to edge. Place on 1" rack, dome with tin foil (securing 4 corners so does not blow around but allowing for heat to pass through). Bake on power level HI for 15 minutes, remove foil, and continue another 20 minutes until done (total bake time about 35 minutes).

(8 servings)



TIPS FOR SNACKS

Nuts: Use pan on 4" rack and cook on HI.

- Pecan or almond pieces: 3-4 minutes.
- Coconut – Unsweetened and shredded: 1-2 minutes

• Whole nuts can be roasted on two layers: For example, start one layer on the liner pan for 6 minutes and then place another pan, filled with nuts, on the 4" rack and continue for another 5 minutes. This doubles the capacity!

Pumpkin seeds: Boil seeds in salt water and let dry completely. Place seeds mixed with oil and salt (or any other seasonings) directly on the liner pan and cook at power level 8 for 6 to 9 minutes, three to five times, stirring in between. If you are using sauces, such as Worcestershire sauce, rinse off the pan in between cooking times to make clean-up even easier.

To dehydrate fruit or meat, place very thinly sliced fruit or thinly sliced ($\frac{1}{8}$ " - $\frac{1}{4}$ " thick) lean meat on racks. Be sure to spread them out for good air flow. To dehydrate fruit, such as apples or pineapples, cook on power level 4 or 5 for about 3 ½ hours, depending on the thickness. To dehydrate meat, cook at power level 4 (refer to page 84).

- Each time the cooking cycle completes, immediately reset the time until food is dehydrated. Do not let the oven rest in between. This will cause excessive moisture.

- You may set the time for up to 9 hours and 59 minutes (when using power levels 1 through 9) with the digital models. However, to prevent excessive moisture, do not let the dome stay attached to the oven when dehydrating is finished.

- If too much moisture builds up in the NuWave® Pro Infrared Oven, lift the dome slightly to let some air escape. This will allow the temperature to fall and the excess moisture to escape.



Taco-Flavored Chicken Wings 🍗💡

- *These wings are a hit with the kids and adults. At a football party I serve guacamole and chips along side the wings.*

- 1 pack taco seasoning
- 3 tablespoons extra virgin olive oil
- 2 tablespoons red wine vinegar
- 2 teaspoons hot pepper sauce
- 4 lbs. chicken wings
- 1 cup guacamole or salsa

In a large resealable plastic bag, combine the taco seasoning, oil and vinegar and hot pepper sauce; add the chicken. Seal bag and turn to coat. Let the mixture sit in the refrigerator for 30 minutes. Place chicken on the 4" rack and on power level HI cook for 15 minutes per side.

Tips: The great thing about Nuwave is that you can be serving the first batch of wings and cooking the others and everything remains hot.

Serve with either guacamole or salsa.

(Makes 2½ dozen)



Chicken Nachos 🍳

- *These Nachos are done in the 12" liner pan.*

- 2 chicken breast
- ½ cup red or green peppers, chopped
- ½ cup sliced onions
- 1 large chopped tomatoes
- 1 (7 ounce) can green chilies, drained and diced
- 1 can small black olives, sliced

Place chicken breast on 4" rack and cook 7-8 minutes on power level HI per side if thawed. If frozen 10-12 minutes a side. Shred the chicken. Spray the liner pan with non-stick cooking spray. Place tortilla chips in liner pan and layer with shredded chicken, cheese and vegetables. Top with another layer of cheese. Cook on power level HI for 10 minutes or until cheese is melted. Serve with salsa.

Taco Pie Casserole

- 1 lb. ground beef
- 1 can refried beans
- 1 jar salsa
- 1 (8 ounce) shredded Cheddar cheese
- ½ bag taco chips
- ¾ cup water.
- 1 package taco seasoning

Brown ground beef; strain grease. Add 1 package of taco seasoning with ¾ cup water. Crush ½ a bag of taco chips into baking pan. Mix salsa, beans and ground beef, then layer all on top of the chips. Place shredded cheese on top of the meat and bean layer. Place on 1" rack and on power level HI cook for 10 minutes. Cheese will be bubbly.

(Makes 1 pie plate)

Pecan Hot Dip 🍳

- *This is the easiest recipe. You can substitute low-fat cheese and sour cream. Use a small casserole dish that is oven safe.*

- 1 softened cream cheese package (8 ounce)
- 2 tablespoons milk
- 1 jar sliced dried beef, cut into tiny pieces (2½ ounce)
- 1 teaspoon onion salt
- ½ cup sour cream

Topping:

- ½ cups chopped pecans
- 2 tablespoons butter

Mix all ingredients in the bowl (except for topping) and spoon into a small casserole dish. Heat and crisp pecans in 2 tablespoons of butter. Sprinkle over cheese mixture. Bake on 1" rack on power level HI for 12 to 15 minutes. These can be made the day ahead and stored, covered, in the refrigerator or held in the freezer for several days before baking. Serve with your favorite cracker or bread.

Sweet Potato Chips

- 2 lbs. sweet potatoes
- 1 teaspoon seasoning salt
- 2 tablespoons olive oil

Wash potatoes and slice them thin. Brush lightly with olive oil. Sprinkle with your favorite seasonings and place on the 4" rack in the NuWave Oven. Crack the dome to let steam escape. Cook on power level 9 for about 8 minutes. Turn potato slices over, season again if desired, and cook at power level 9 for 3 to 4 minutes or until crispy.

Zucchini Bran Muffins

- 1¾ cups flour
- 3 teaspoons baking powder
- ½ teaspoon salt
- ½ cup brown sugar
- 1 cup All-Bran® cereal
- 1 cup milk
- 1 cup grated zucchini

First mix cereal and milk, let stand until soggy. Mix all other ingredients. Grease muffin tins. Place on liner pan and bake on power level HI for about 20 minutes.

Tips: Add 2 tablespoons of cocoa powder and ½ cup chocolate chips for a sweet touch.



Hawaiian Cheese Bread 🍞

- This is another crowd pleaser. This is a great snack for football as a tailgating snack. Put all this together in the foil and pop it in the NuWave.

- 1 loaf Hawaiian sweet bread
- 1 block (8 ounce) Swiss cheese
- 1 small red onion, sliced
- ½ stick butter, melted
- 1 tablespoon garlic, minced
- 1 teaspoon salt

Cut bread diagonally into 1" slices to within 1" of bottom. Repeat in opposite direction. Cut Swiss cheese into ¼" slices; cut slices into small pieces. Insert into bread. Combine the onion, butter, garlic, and salt, then spoon over bread. Wrap in foil and place on 1" rack and on power level HI cook for 15 to 17 minutes. The cheese should be melted and onions softened.

(10-12 servings)

Sausage Balls 🍞

- This is a recipe from Bisquick. Kids love them. Better yet ... so do adults.

- 3 cups Bisquick
- 2 cups grated Cheddar cheese
- 1 lb. fresh ground pork sausage (hot or mild)

Mix all ingredients together. If not moist enough add a little water. Form into 1" balls. Place on the silicone liner or a pan that is oven safe (any pan that you use in a regular oven you can use in the Nuwave). Bake for 10 minutes on the 4" rack on power level HI. Serve warm (these freeze well before or after you bake them).

(Makes 3 dozen)

Pesto Sauce (Great with Beef, Lamb, Poultry and Seafood)

- 2 cups packed fresh, basil leaves
- ⅓ cup pine nuts
- 2 cloves garlic
- ½ cup olive oil
- salt to taste

Place the basil, nuts, and garlic in your food processor or blender. With the machine running slowly pour in the oil until it forms into a thick paste. Add more oil if too thick. Season and store in a jar with a thin film of mayonnaise on top to prevent discoloration.

Hollandaise Sauce (Great with Vegetables or Eggs)

- ¼ lb. butter, cut into 4 equal pieces
- 3 large egg yolks
- juice of half a lemon
- add white pepper, Tabasco sauce, Worcestershire sauce to taste

Heat the lemon for 4 minutes in the NuWave and you'll get almost twice the amount of juice. Mix the butter, egg yolks, and lemon juice in a 2 cup measuring cup or glass bowl. Heat and stir in 15 second increments until the sauce thickens, about 80 seconds depending on the starting temperature of the ingredients.



Dehydrated Beef

- 1 lb. lean beef sliced thin (no more than ¼" thick)
- ¼ cup soy sauce
- 3 tablespoons Worcestershire sauce
- 1 tablespoon garlic powder
- 3 tablespoons liquid smoke
- cayenne pepper to taste

Place all ingredients in plastic bag and marinate overnight. Place pieces of meat on liner pan and 4" rack (when using a 2" rack you can use 3 different levels). Do not allow meat to touch or it will slow the dehydrating. Dehydrate on power level 4 for about 3 hours (about 2 hours and 45 minutes if less than ¼" thick). Tent the dome during the last 5 minutes. Pat excess moisture with paper towel, cool, and store.

Trail Mix

- 1 cup dried cranberries
- 1 cup dried blueberries
- 1 cup dried pineapple
- 1 cup dried apple pieces
- 1 cup peanuts
- 1 cup cashews
- 1 cup almonds
- 1 cup mini marshmallows
- 1 cup chocolate chips
- 1 cup peanut butter chips
- 1 cup white chocolate chips

Use NuWave to dehydrate the fruit. Mix all ingredients together in a large bowl. Great to take along on hikes, a day in the park or on road trips.

To store, place in sandwich bags or airtight containers. ENJOY!

Spiced Pecans

- 1 package taco seasoning mix
- 5 tablespoons sugar
- 2 teaspoons cinnamon
- ¼ teaspoon cayenne pepper
- ¼ cup orange juice
- 2 cups pecan halves

Spray liner pan with oil. In small saucepan, combine 1 tablespoon of the seasoning mix, 4 tablespoons sugar, the cinnamon and ¼ teaspoon cayenne pepper; mix well. Stir in orange juice. Bring to a boil over medium heat. Remove from heat. Add pecans. Stir until the pecans are well coated. Spread evenly in liner pan. NuWave on power level HI for 7 minutes. Immediately remove dome and stir pecans. NuWave on power level HI for 2 minutes. Meanwhile, in small bowl, combine remaining seasoning mix, remaining tablespoon of sugar, and remaining ¼ teaspoon cayenne. Remove pecans from oven. Place pecans in bowl and toss. Some pecans will stick together. Gently break them apart; continue to toss. Spread out pecans over a cooling rack. Gently shake to remove any residual seasoning mixture. Store in an airtight container.



Nuwave[®]
PRO INFRARED OVEN

IMPORTANTES MEDIDAS DE SEGURIDAD

Cuando utilice productos eléctricos, especialmente cuando haya niños presentes, se deben tomar las precauciones básicas.

LEA TODAS LAS INSTRUCCIONES ANTES DE USAR EL PRODUCTO.

PELIGRO - Para reducir el riesgo de electrocución:

1. Lea todas las instrucciones antes de usar el producto.
2. Nunca colocar producto cerca donde se pueda caer en agua o otra clase de líquidos.
3. Nunca trate de salvar producto si se cae en agua desconecte rápido.
4. Nunca deja el cable, clavija o la cabeza cerca de agua o otra clase de líquidos.

AVISO - Para reducir el riesgo de quemaduras, electrocución, fuego o lesión:

1. Este electrodoméstico no deberá ser utilizado por niños. Tenga más cuidado cuando utilice el producto cerca de niños.
2. Utilice este electrodoméstico para su propósito. No utilice cualquier otro accesorio no recomendado por el fabricante. Pueden ocasionar fuego, descarga eléctrica o lesiones personales.
3. Nunca opere este electrodoméstico si tiene el cable o la clavija dañados; si no opera adecuadamente; si ha sido dañado o se ha sumergido en agua. En cualquiera de esos casos, regrese el electrodoméstico a un centro de servicio al cliente autorizado para su revisión, reparación o ajuste.
4. Mantenga el cable alejado de superficies calientes.
5. Siempre desconecte el aparato estirando la clavija. NO desconecte estirando el cable.
6. Nunca force la clavija en un enchufe.
7. No se opera al aire libre o en donde se utilicen aerosoles, así como en lugares donde se administre oxígeno.
8. No deje el cable colgando en la orilla de una mesa o una barra.
9. No colocar cerca de un calentador de gas o eléctrico o un horno caliente.
10. No mueva el electrodoméstico cuando contenga comida caliente. Tome especial precaución cuando saque una cacerola caliente o mueva la rejilla caliente.
11. Antes de desconectar el aparato apáguelo primero.
12. No utilice este electrodoméstico para otro uso que no sea para el que está planeado.
13. Revise todo el cableado y partes electrónicas. Tenga cuidado con cables o clavijas dañados.
14. Este electrodoméstico está diseñado para uso casero únicamente. No es conveniente para un uso continuo u operación comercial.

15. No desarme el producto. Las partes no sirven por sí solas.
16. No deje el electrodoméstico desatendido si está en uso.
17. Use las asas cuando levante el domo de la base.
18. No toque las superficies calientes. Utilice las asas o use guantes para hornear.
19. Detenga o pause el horno antes de quitar el domo; revisar o voltear la comida. El domo y la cabeza de potencia deberán colocarse en el sujetador del domo.
20. Siempre quite el domo lejos de usted para que el vapor que escape se mantenga alejado de su cara.
21. Si el cable está dañado, deberá ser cambiado por un cordón especial del fabricante o su agente de servicio.
22. Tenga cuidado con la grasa caliente.
23. Mantenga este manual a la mano para su fácil consulta en el futuro.

GUARDE ESTAS INSTRUCCIONES

Información Eléctrica

El largo del cable de este electrodoméstico fue seleccionado para reducir los riesgos que puedan ocurrir con un cable largo. Existen cables de extensión disponibles, los cuales pueden ser utilizados si esto se hace con cuidado. Si un cable de extensión es utilizado: (1) la clasificación eléctrica marcada deberá ser al menos tan grande como la del aparato y (2) el cable más largo deberá ser arreglado para que no se doble sobre la mesa o barra donde podría ser accidentalmente estirando o tropezarse.

Ciertos modelos de electrodomésticos pueden tener una clavija polarizada (una cuchilla es más gruesa que la otra). Esta clavija pretende ser usada en una entrada polarizada de una sola forma. Si la clavija no cabe completamente en la entrada, voltéela. Si aún así no cabe apropiadamente, contacte a un electricista capacitado. No intente modificar la clavija de ninguna manera.



ADVERTENCIA



Riesgo de descarga eléctrica. Utilicé con un sistema eléctrico adecuado. No se use si el cable o la clavija están dañados.

ADVERTENCIA: Todos los productos metálicos en el horno, como la cacerola y la rejilla, pueden calentarse mucho durante el uso. Por favor tenga cuidado cuando retire estas partes de un horno caliente. Siempre utilice guantes para hornear o agarraderas de ollas. Deje enfriar la cacerola y la rejilla por completo antes de limpiarlas. Al abrir el domo, éste se puede expandir ligeramente cuando esté caliente. En raras ocasiones, la cabeza de potencia podría separarse por sí sola del domo completamente, causando así el escape de aire caliente.

DIAGRAMA DE EL MONTAJE DE LAS PARTES

Panel de Control Digital
NuWave Pro / Digital

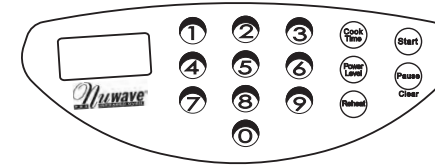

Discos de Control Manual
NuWave Analog

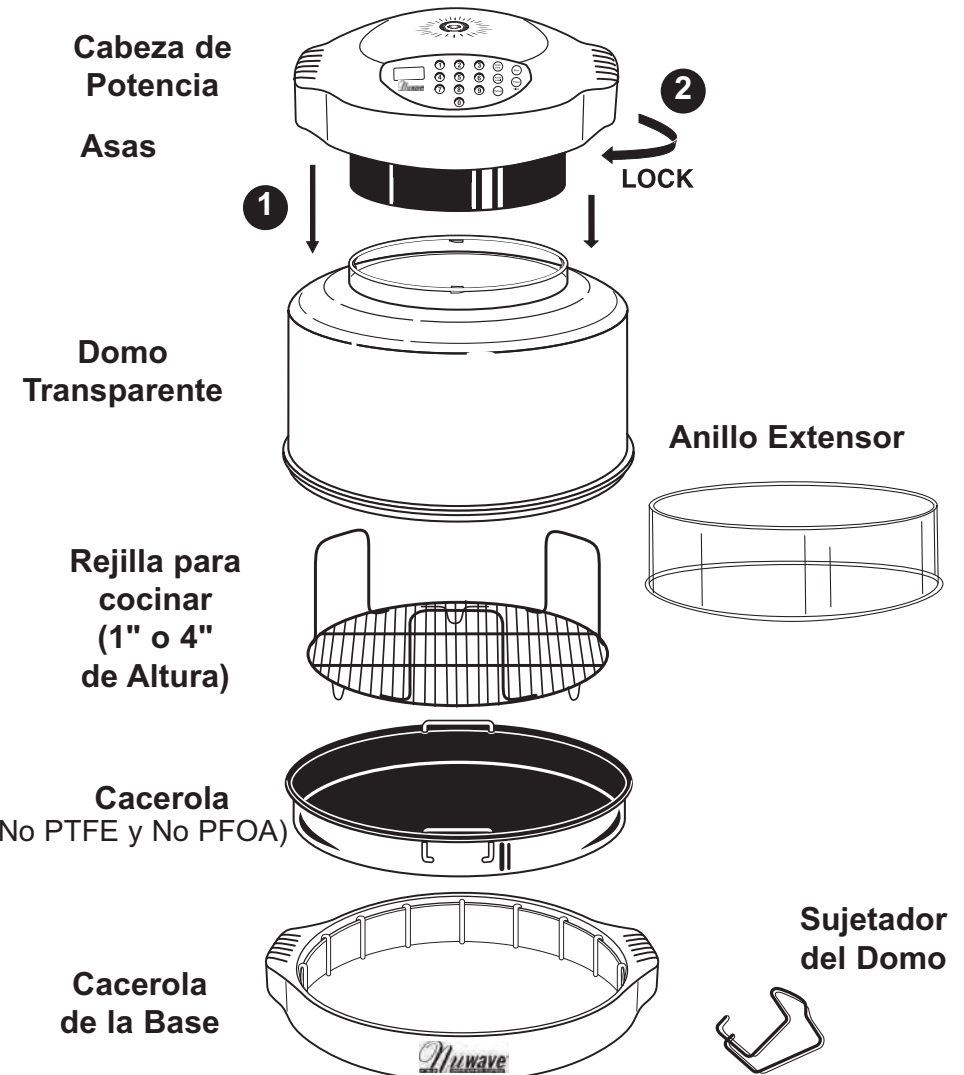
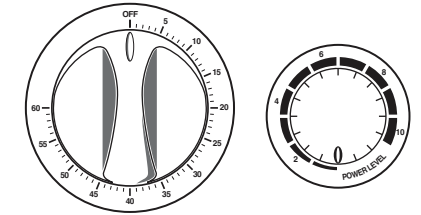

Antes de usarse:

Antes de usarse, lave el domo, la cacerola, la base y la rejilla en agua tibia con jabón o lávelos en el lavavajillas.

IMPORTANTE: NO LAVE NI SUMERJA LA CABEZA DE POTENCIA EN AGUA O EN EL LAVAVAJILLAS. LA SUPERFICIE EXTERNA PUEDE SER LIMPIADA CON UN PAÑO HÚMEDO O UNA ESPONJA.

Manera de Asamblar:

- Coloque cacerola de la base en una superficie firme y estable.
- Coloque la cacerola dentro de la base. Cuando lo haga, asegúrese de que las asas estén posicionadas hacia abajo, porque si no es así, el domo no podrá encajar adecuadamente.
- Coloque la rejilla de doble nivel sobre la cacerola de acuerdo a las instrucciones de cocinar.
- Coloque la comida sobre la rejilla.
- Coloque el domo sobre la comida y sobre la base. El domo debe encajar en la base uniformemente.
- Coloque la cabeza de potencia dentro del borde del domo y asegúrela girándola en sentido de las manecillas del reloj hasta que los seguros se enganchen.
- Establezca el tiempo para cocinar y el nivel de potencia de acuerdo a las instrucciones para cocinar.

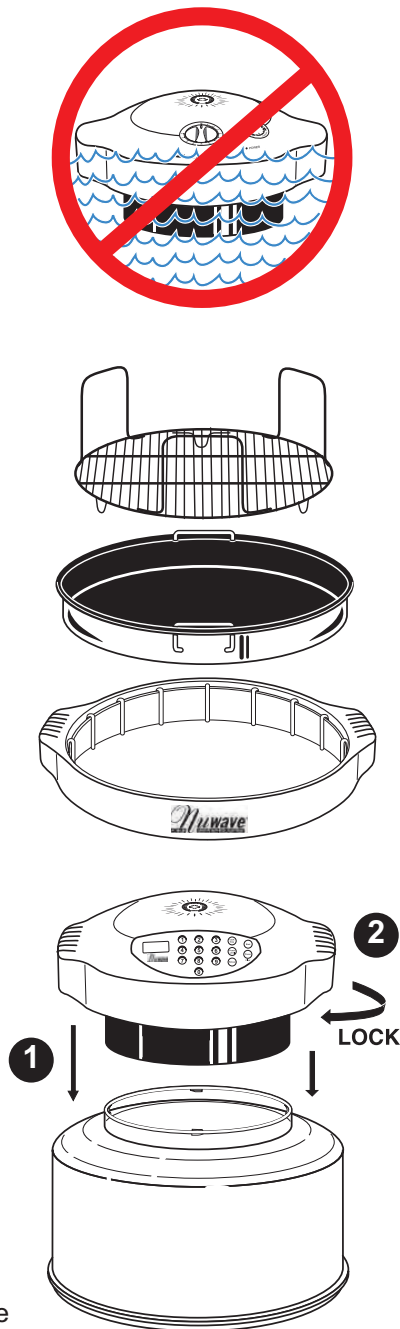

Instrucciones Generales de Uso

- Asegúrese de que la unidad esté bien conectada a una salida de tierra y que el cable no esté en contacto con ningún objeto caliente.
- Asegúrese de que la cacerola haya sido colocada dentro de la base.
- No coloque la cacerola directamente en un quemador de estufa o alguna otra fuente de calor, ya que se puede dañar.
- Los platos de vidrio o metal, cacerolas o papel aluminio, así como cualquier material que sea usado en un horno convencional pueden también ser utilizados en el horno NuWave de forma confiable.

Cómo Abrir el Ensamble de la Cabeza de Potencia y el Domo

Asegúrese de que la cabeza de potencia esté firmemente asegurada en el domo, entonces el ensamblaje completo puede ser levantado fácilmente y separado como se muestra en los pasos 1, 2 y 3. Ponga el sujetador del domo en cualquiera de los lados de las asas de la base. Asegúrese de que ambas patas del sujetador estén puestas dentro del asa y que el sujetador esté apoyado horizontalmente en una superficie plana. Después el ensamblaje de la cabeza de potencia y el domo puede ser colocado en el sujetador como se muestra en el paso 3.

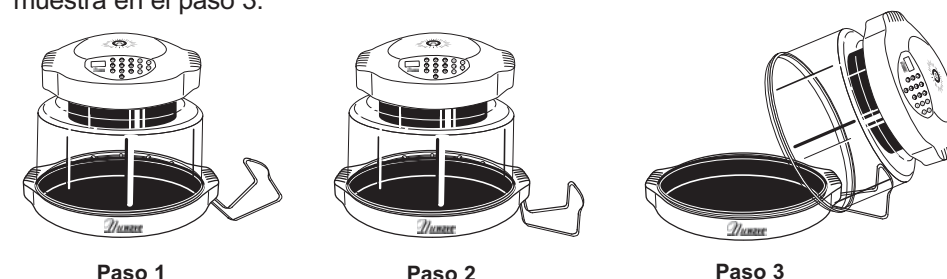

Instrucciones para Cocinar

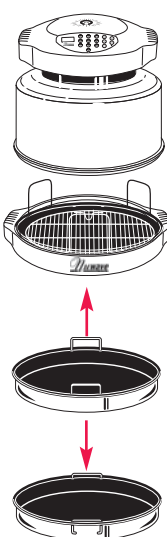

Levante el domo solamente de las asas en la cabeza de potencia. Una vez que la cabeza de potencia y el domo estén ensamblados, las asas de la cabeza de potencia le permitirán levantarlos juntos para quitarlos o revisar la comida. Cuando quite la cacerola estando todavía muy caliente, sea extremadamente cuidadoso y siempre utilice guantes para hornear. Las asas plegables sirven para ese propósito. Para mejores resultados, siga las instrucciones acerca del tiempo, potencia y altura de la rejilla proporcionadas en la tabla de preparación y las recetas.

No requiere de precalentamiento.

NOTA: El horno NuWave utiliza temperaturas para cocinar más bajas para evitar que los alimentos se quemen, al mismo tiempo que fomenta una forma de cocinar más rápida. A continuación se presenta la relación entre el nivel de potencia y la temperatura dentro del horno para su referencia.

PRECAUCIÓN	
	<p>No toque el domo u otra superficie del área de cocinar durante la operación del aparato. El aire dentro del domo puede alcanzar una temperatura de 342°F (172°C), por lo que la superficie se encuentra muy caliente y puede causar quemaduras. No abra el domo o quite la cabeza de potencia mientras esté uncionando. Gire el disco de tiempo hasta "OFF" primero para apagarlo antes de retirarlo, o si es horno digital, presione "PAUSE".</p>

Anillo Extensor:

Anillo extensor para el NuWave Oven se utilizará para manejar niveles diversos de cocinado junto con las diferentes rejillas o, para cocinar cierta comida que exceda el tamaño normal para caber en el domo regular. Generalmente, cualquier alimento (como un jamón o pavo) que sobrepase las 10 libras necesitará utilizar la Anillo extensor para un cocinado óptimo.

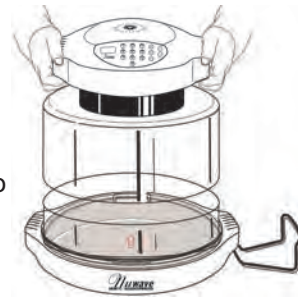

Uso y Cuidado:

Al igual que el domo original, el anillo extensor está hecho de policarbonato Lexan de alto impacto. No deberá ser limpiado con ningún cáustico agresivo pero sí se puede limpiar en lavavajillas sin problema alguno.

Instrucciones:

El anillo extensor deberá ser colocada entre el domo original y la base. Al utilizar el anillo se ampliará el espacio disponible para cocinar del NuWave Oven por alrededor de 440 pulgadas cúbicas. Cuando colóque el Anillo en el NuWave Oven, asegúrese de que embone firmemente en el domo. Cuando el Anillo es colocado debajo del domo de forma incorrecta, los bordes que deben coincidir no embonan apropiadamente. Por favor tenga precaución cuando use el extensor. Si no se utiliza apropiadamente, el calor o el vapor podrían quemar su piel o alterar el tiempo de cocinado. El anillo extensor deberá ser utilizado como un accesorio del NuWave Oven y nunca para reemplazar el domo, la base o cualquier otro componente del NuWave Oven.

Kit de Anillo Extensor:

REJILLA DE 2 PULGADAS

La Rejilla de 2 pulgadas para el Horno NuWave puede ser usada de diversas formas:



1. Puede ser la rejilla principal con o sin la el anillo extensor.
2. Con el anillo extensor, puede ser posicionada encima de la Rejilla de 4" o debajo de ella para tener más espacio para cocinar a diferentes niveles.
3. Sin el anillo extensor, la Rejilla de 2" puede también facilitar el cocinar a diferentes niveles al crear una tercera superficie entre la cacerola y la rejilla de 4".
4. Usted puede utilizar dos rejillas extras de 2" sobre y debajo de la rejilla de 4", especialmente para deshidratación.

Nota: La rejilla de 2" debe utilizarse solamente en las posiciones y para los propósitos mencionados abajo de esta pagina. Cualquier otro uso podría afectar el tiempo de cocinado y la calidad.

Uso y cuidado:

Esta rejilla puede ser lavada en lavavajillas, pero no deberá ser limpiada con ningún cáustico agresivo.

Reglas Generales:

- Coloque la comida que necesite de un largo tiempo de cocción en la rejilla más cercana al elemento caliente como papas, zanahorias, etc. y coloque vegetales suaves en las rejillas inferiores, como champiñones, tomates, etc.- O - hágalo al revés, colocando comida que se va a cocinar por más tiempo en la cacerola y, cuando esté casi lista, coloque la comida que se cocina más rápido encima y continúe hasta concluir el ciclo.
- Combine comida que requiera más o menos del mismo tiempo para cocinarse. Por ejemplo, carne de cerdo o pollo con trozos de papa; pescado con tomates dulces; o carne de res con papas al horno.
- Coloque papel aluminio debajo de cualquier comida que pudiera gotear sobre alguna otra.
- Recuerde que los rayos infrarrojos no penetran el aluminio, pero el calor circula dentro del horno.
- Si la comida de arriba queda lista antes, quite la(s) rejilla(s) superiores y continúe cocinando lo de abajo hasta que quede listo.
- Utilice platos poco profundos o cacerolitas ligeras de aluminio para cocinar.
- Para calentar el pan, colóquelo en la rejilla de abajo o en la cacerola. Para tostarlo, colóquelo en las rejilla de arriba.



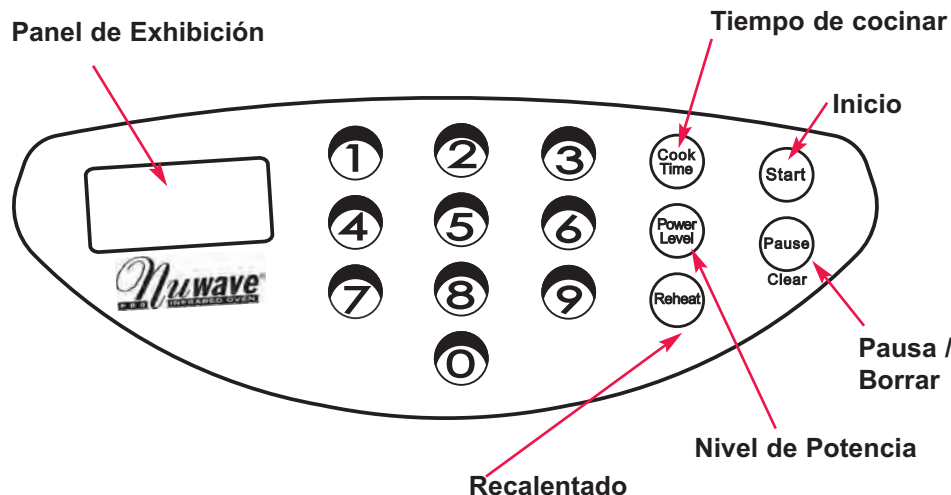

INICIO RÁPIDO:

Para comenzar a cocinar, presione el botón de **COOK TIME**, ingrese el tiempo requerido, presione **START**. Si va a cocinar a otro nivel que no sea el Alto (10), se necesitará el uso del botón de Power Level. Para instrucciones más completas vea lo siguiente:

PANEL DE CONTROL EN LA CABEZA DE POTENCIA - Debe aparecer "0" en la ventana cuando el programa esté limpio.

AJUSTE DEL TIEMPO DE COCINAR:

Presione el botón de **COOK TIME**. El indicador de MIN aparecerá en la esquina inferior derecha del panel de exhibición. Ingrese el tiempo requerido en horas y minutos presionando los números correctos. Por ejemplo, 1 hora y 30 minutos se ingresaría presionando 130. El panel de exhibición mostrará 1:30. Si el tiempo requerido es en minutos sólo necesita ingresar uno o dos números. Por ejemplo, 5 minutos sólo presione 5; 46 minutos, presione 46. Si necesita corregir los números, borre lo que ingresó presionando el botón de pause/clear dos veces. Después ingrese nuevamente los números correctos.

COMIENCE A COCINAR:

Presione **START** para comenzar a cocinar. El tiempo de cocinar restante aparecerá en el panel de exhibición y los dos puntos (:) entre las horas y los minutos parpadearán en encendido y apagado. El horno parará de cocinar cuando el tiempo se haya terminado y sonará para avisar sobre esta acción.

PAUSA / BORRAR:

Para **PAUSAR** el tiempo de cocinar, presione el botón de Pause/Clear una vez. El tiempo restante permanecerá en el panel de exhibición pero los dos puntos (:) no parpadearán. Para **BORRAR** el tiempo de cocinar, presione el botón de Pause/Clear dos veces. El tiempo restante de cocinar será borrado completamente y un "0" aparecerá. restante aparecerá entonces.

AJUSTE DEL NIVEL DE POTENCIA:

- Presione el botón de **POWER LEVEL**.
- El nivel Alto aparecerá como predeterminado en el panel de exhibición (nivel de potencia 10).
- El indicador PWR se muestra en el panel de exhibición. Para anular el determinado y cambiar el nivel de potencia, sólo presione la potencia para cocinar deseada de 1(nivel de potencia bajo) a 9 (cerca del nivel de potencia alto). La potencia se ingresa con un simple dígito como 9 ó 3. Para reajustar a Alto presione 0.
- Verifique la potencia correcta puesta en el panel de control.
- Si la potencia puesta necesita ser corregida, reingrese el número requerido.
- Para revisar el nivel de potencia mientras cocina, presione **POWER** una vez y el ajustador aparecerá en el panel de exhibición por unos segundos. El tiempo restante aparecerá entonces.

NOTA: El tiempo de cocinar **máximo** permitido para niveles de potencia **Alto es de 2 horas**, si se ingresa un tiempo más alto, el aparato volverá a 2:00 horas automáticamente. Simplemente agregue más tiempo después de que el tiempo inicial de 2 horas haya terminado. Para **ajustes de potencia bajos**, el tiempo máximo permitido es de **9 horas y 59 minutos**.

MODO DE USO DE LOS HORNO NUWAVE DIGITAL

Nivel de Potencia	Temperatura del Horno	Presionar el Boton	Panel Display
10(HI)	342°F (172°C)	0 (High)	PHI
9	325°F (163°C)	9	P90
8	300°F (149°C)	8	P80
7	275°F (135°C)	7	P70
6	250°F (121°C)	6	P60
5	225°F (107°C)	5	P50
4	175°F (79°C)	4	P40
3	150°F (66°C)	3	P30
2	116°F (47°C)	2	P20
1	106°F (41°C)	1 (Low)	P10

FUNCION DE RECALENTADO:

Este puede ser utilizado para recalentar porciones individuales de comida. Para activar la funcion de recalentado, asegurese de que el programa este borrado (pausa/boton clear). En la pantalla se leera 0. Presione el boton **REHEAT** luego presione **START**. Esta funcion programara el nivel de potencia alto por 4 minutos. Presione **START**. La alarma sonara cuando el tiempo haya terminado. Por ejemplo, si usted esta recalentando una rebanada de pizza sobrante, simplemente colóquela en la rejilla de 4 pulgadas, presione reheat y luego start. Si usted recalienta un plato de arroz o fideos, coloque una porcion individual en un plato adecuado para horno o en un pedazo de papel aluminio. Si desea el arroz o los fideos massuaves, cubra con papel aluminio y agregue un poquito de agua.

MODO DE USO DE LOS HORNOS NUWAVE DE DISCOS DE CONTROL MANUAL

AJUSTE DEL TIEMPO DE COCINAR

El disco de Tiempo de Cocinar se localiza frente a la cabeza de potencia. Usted puede girar el disco al tiempo deseado. La luz del indicador de potencia se encenderá. Cuando el tiempo caduque, el disco regresará a la posición de "OFF" (Apagado). El tiempo máximo de cocinar es de una hora. Mientras cocina, usted puede agregar o reducir tiempo girando el disco de tiempo. Así como todos los relojes mecánicos, para mayor precisión, gire el disco hasta pasar el tiempo deseado, **después gírelo nuevamente de regreso al tiempo deseado**. Por ejemplo, si el tiempo deseado es de 5 minutos, gire el disco hasta 10 minutos y luego regréselo a 5.

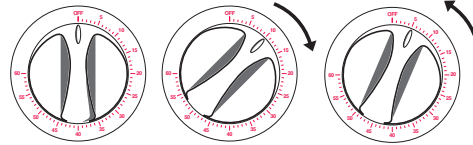

Importante: Para los modelos americanos, antes de revisar o sacar la comida, gire el disco hasta la posición "OFF" para apagar el aparato.

NO ABRA Ó quite la cabeza de potencia mientras esté funcionando.

AJUSTE DEL NIVEL DE POTENCIA

- El disco de nivel de Potencia está localizado frente a la cabeza de potencia.
- Gire el disco de nivel de potencia hasta el nivel deseado, de 1 a 10 (Alto).
- Puede regular la potencia (más alta o más baja) mientras cocina

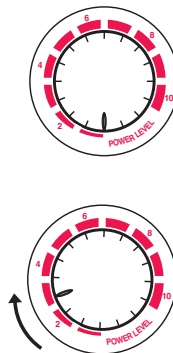

* Nivel de potencia es diferente que el horno digital

PARA COMENZAR A COCINAR

Gire el disco del tiempo de cocinar para ajustarlo al tiempo deseado. (Como con cualquier otro reloj, puede girar el disco hasta pasar el tiempo deseado y luego regresarlo para un ajuste más exacto).

PARA PAUSAR Ó TERMINAR DE COCINAR

Gire el disco de tiempo de cocinar hasta la posición "OFF", la campana sonará y el horno parará de cocinar.

Nota: Para algunos modelos, cuando la cabeza de potencia se levante y el interruptor de seguridad localizado en las asas se active, la unidad automáticamente se apagará por seguridad. Para reactivar la unidad, coloque nuevamente la cabeza de potencia en la posición correcta y gire el disco de tiempo de cocinar a la posición "OFF" primero, después ajuste al tiempo restante y se reanudará el cocinar.

INSTRUCCIONES DE CUIDADO Y LIMPIEZA

INSTRUCCIONES GENERALES:

Desconecte la unidad antes de limpiarla. El domo y todas las otras partes, excepto la cabeza de potencia se pueden lavar en un lavavajillas sin problema. Proteja las superficies de metal y plástico; no use limpiadores cáusticos ó fibras. Límpiense después de cada uso. La superficie exterior de la cabeza de potencia puede ser limpiada con un paño húmedo.

CONSEJOS IMPORTANTES:

1. Revise el contacto de electricidad para un buen funcionamiento. No opere la unidad con otros electrodomésticos más grandes en el mismo contacto. Revise el nivel de potencia si la unidad cocina demasiado lento.
2. Revise si la clavija está bien conectada en el contacto.
3. Siempre apague y desconecte el aparato antes de limpiarlo.
4. El domo se puede empañar si la comida no se retira pronto cuando el tiempo de cocinar haya terminado. El vapor y empañamiento se pueden evitar haciendo lo siguiente:
 - Saque la comida pronto después de que el tiempo de cocinar haya concluido.
 - Si desea mantener la comida caliente hasta que se sirva, reajuste el tiempo de cocinar a un nivel bajo (1 ó 2).



LA GARANTÍA DEL FABRICANTE - El sistema para cocinar mediante luz infrarroja incluye cabeza de potencia, domo, rejilla para cocinar, cacerola, base, y todos los componentes eléctricos para estar libre de defectos ó composturas bajo un uso exclusivo de casa, cuando se opera de acuerdo a las instrucciones escritas del Fabricante incluidas con cada unidad para un (1) año desde la fecha de compra. El fabricante proporcionará las partes necesarias y la mano de obra para reparar cualquier parte del sistema para cocinar mediante luz infrarroja en el Departamento de Servicio de Hearthware Home Products. Después de la fecha de caducidad de la garantía, el costo de las partes ó mano de obra será responsabilidad del dueño.

LA GARANTÍA NO CUBRE - La cubierta anti-adherible de cualquier parte del sistema. La Garantía Limitada será inválida si alguien no autorizado realiza una reparación ó la placa del número de serie es retirada ó estropeada. El deterioro normal del acabado por el uso ó la exposición no está cubierto por esta garantía. La Garantía Limitada no cubre fallas, daños ó funciones inadecuadas causadas por accidentes, fenómenos naturales (cómo relámpagos), irregularidades en la energía eléctrica, alteraciones, abuso, malversación, mal empleo, ambientes corrosivos, instalación inapropiada, falla de operación de acuerdo con las instrucciones escritas del Fabricante, uso anormal ó comercial.

PARA OBTENER EL SERVICIO- El dueño tendrá la obligación y responsabilidad de: Pagar todos los servicios y partes no cubiertas por la garantía; Prepagar el costo de envío redondo al Departamento de Servicio para cualquier parte o sistema devuelto bajo esta garantía; Empacar cuidadosamente el producto utilizando material de relleno para evitar daños durante el tránsito del mismo. El empaque original es ideal para este propósito. Incluya en este empaque el nombre del dueño, dirección, teléfono para localizarlo durante el día, una descripción detallada del problema y su "Número RGA". (Llame al **1-888-NUWAVE1 (689-2831)** o envíe un correo electrónico a servicios@hearthware.com para obtener su Número RGA (Autorización de Devolución de Productos).

Proporcione el modelo y número de serie del sistema para cocinar, así como prueba del día de compra (copia del recibo) cuando reclame bajo esta garantía.

OBLIGACIONES DEL FABRICANTE- La obligación del Fabricante bajo esta Garantía Limitada se restringe a reparar o reemplazar cualquier parte del sistema para cocinar mediante luz infrarroja expresamente cubierta por esta Garantía Limitada bajo previa revisión y detección de que el defecto surgió bajo un uso normal. La Garantía Limitada es aplicable únicamente dentro de los Estados Unidos y sólo para compradores u otros canales de distribución autorizados por el Fabricante.

LA GARANTÍA LIMITADA NO PUEDE SER ALTERADA, CAMBIADA O RENOVADA EXCEPTO QUE SE HAGA MEDIANTE UN INSTRUMENTO ESCRITO HECHO POR EL FABRICANTE. EL REMEDIO PARA REPARAR O REEMPLAZAR PROPORCIONADO POR ESTA GARANTÍA LIMITADA ES EXCLUSIVO. BAJO NINGUNA CIRCUNSTANCIA EL FABRICANTE SERÁ RESPONSABLE POR ALGUNA CONSECUENCIA O DAÑO CAUSADO A ALGUNA PERSONA, AÚN SI ESTE ES CAUSADO POR NEGLIGENCIA DEL FABRICANTE, INCLUYENDO NO LIMITES, DAÑOS POR PERDIDA DE USO, COSTOS DE SUSTITUCIÓN, DAÑOS PROPIOS O PÉRDIDA DE DINERO.

Algunos estados no permiten la exclusión o limitación de daños incidentales o consecuentes, así que la limitación arriba mencionada no puede aplicar. Esta Garantía Limitada otorga derechos legales específicos, y puede haber también otros derechos que pueden variar de acuerdo al estado.

EXCEPTO POR LO QUE SE EXPRESE DE LO CONTRARIO ARRIBA, EL FABRICANTE NO GARANTIZA ALGO QUE SURJA DE LA LEY O DE LO CONTRARIO, INCLUYE SIN LIMITACIÓN, LAS GARANTÍAS IMPLICADAS DE MERCANTILISMO Y BUENA FORMA PARA UN PROPÓSITO PARTICULAR PARA CUALQUIER OTRA PERSONA.

LEA SU MANUAL DE USUARIO. SI USTED AÚN TIENE DUDAS SOBRE LA OPERACIÓN O LA GARANTÍA DEL PRODUCTO, POR FAVOR CONTACTE A HEARTHWARE HOME PRODUCTS, INC.

At: **1-888-NUWAVE1 (689-2831)**, correo electrónico: servicios@hearthware.com



Hearthware Home Products anuncia orgullosamente que los Hornos NuWave cumplen al 100% con la norma RoHS de "restricción de uso de ciertas sustancias peligrosas en equipo electrónico". El Directivo de RoHS es efectivo desde el 1 de Julio del 2006 y prohíbe poner en el mercado estadounidense equipo electrónico que contenga más de los niveles permitidos de 6 tipos de metales pesados y químicos potencialmente dañinos como plomo, cadmio, mercurio, cromo hexavalente, polibrominato bifenil (PBB), y polibrominato difenil eter (PBDE) resistente al fuego.

Materials Restringidos por RoHS

Material & Perfil Toxicológico	Concentración Máxima
Plomo (Pb)	0.1% del peso
Mercurio (Hg)	0.1% del peso
Cadmio (Cd)	0.01% del peso
Cromo Hexavalente (Cr-VI)	0.1% del peso
Polibrominato Bifenil (PBB)	0.1% del peso
Polibrominato Difenil Eter (PBDE)	0.1% del peso

Actualmente no hay ninguna ley de ambiente que obligue a alguien en Estados Unidos a acatar este lineamiento; sin embargo, nosotros tomamos la decisión conciente, hace más de un año y medio, de seguir voluntariamente esta directriz al fabricar nuestros hornos NuWave y así hacer nuestra parte para ayudar a preservar el medio ambiente. Si desea saber más sobre el Directivo de RoHS visite: <http://en.wikipedia.org/wiki/RoHS>

EL HORNO NUWAVE

SISTEMA PARA COCINAR MEDIANTE LUZ INFRARROJA
www.NUWAVEOVEN.com www.NUWAVEOVEN.net

Para obtener el servicio de garantía, contacte nuestro departamento de servicio a su número de servicio gratuito: **1-888-NUWAVE1 (689-2831)**

Hearthware Home Products 880 Lakeside Drive, Gurnee, IL U.S.A.
www.HEARTHWARE.com

Protected under U.S. Patents : 6,201,217; 6,617,554; 6,917,017; 6,936,795; D487,670; D490,648. International Patents: EP 1 446 981

Other U.S.A. and other International Patents Pending

Model 20008 : 120V/60Hz, 1225W

Models 20201~20204, 20301~20304

Models 20221~20299, 20321~20399 : 120V/60Hz, 1500Watts

Models 20205~20210, 20305~20310 : 230V/50Hz, 1500Watts

Models 20213, 20214, 20313, 20314 : 220V/60Hz, 1500Watts



Equipo Supremo para Pizza de NuWave:

La Pinza para Pizza de acero inoxidable de NuWave El mango con resorte y fácil agarre le permite sujetar las tenazas de acero inoxidable y cerrarlas, permitiéndole voltear su pizza de forma segura, además de los calzones, quesadillas y muchos otros!

El Forro para Pizza de NuWave (Cumple con la norma FDA)

Le permite a usted hornear su costra de pizza sin cocinar de más su queso o ingredientes favoritos. La ingeniosa superficie de silicón no se pegará al queso, más bien le quitará la grasa no deseada a la pizza.

El Servidor para Pizza de acero inoxidable de NuWave Dos grandes utensilios en uno! El Servidor de Pizza NuWave con sus diferentes superficies de acero inoxidable y su mango de fácil agarre le permitirá cortar y servir su pizza con facilidad.

La 100% nueva Tabla para cortar de Bambú de NuWave Con nuestra única tabla para cortar de Bambú usted cuidará sus muebles de cocina, ahorrará dinero y ayudará también a cuidar del medio ambiente. Esta tabla es multifuncional con un lado plano para cortar pizzas y pan y el otro rugoso para usarlo con comida jugosa.

Su orden puede contener algunas cosas indicadas en la parte de arriba. Para comprar el producto llame a nuestro servicio al cliente al 1-888-689-2831 o www.nuwaveoven.net



INDICACIONES:

Asegúrese de que la rejilla reversible esté colocada como la de 4" en la cacerola del NuWave.

1. Coloque un Pizza Liner Echo de Silicón sobre la rejilla.

2. Coloque la pizza boca abajo sobre el Pizza Liner sobre la rejilla de (4 pulg). Cocine a nivel alto (HI) hasta que la costra de la pizza esté ligeramente dorada. (Por favor revise las Recomendaciones de Hornear para el tiempo)

3. Para dar uso do el Pizza Flipper. Abra la pinza y deslícela por debajo del Pizza Liner y sobre la costra.

4. Utilice la manija para cerrarla hasta que la pizza quede bien sujeta.

5. Mientras detiene la manija, gire la pizza y el Pizza Liner completamente al revés y colóquela así nuevamente en la rejilla.

Entonces la pizza quedará boca arriba ahora.

6. Quite el Pizza Liner y cocine a nivel alto (HI) por 3-5 minutos o hasta que el queso esté derretido a su gusto.

Equipo Supremo para Pizza de NuWave:

La Pinza para Pizza de acero inoxidable de NuWave

El Forro para Pizza de NuWave

El Servidor para Pizza de acero inoxidable de NuWave

La 100% nueva Tabla para cortar de Bambú de NuWave



INDICACIONES:

Para Cortar y servir su pizza con el Servidor para Pizza de acero inoxidable de NuWave.

Rebanador:

Tome el mango de tal forma que el servidor esté arriba para que usted pueda cortar la pizza.

Rebanador con dientes:

Tanto el cortador de pizza como el servidor pueden ser utilizados para rebanar alimentos como pizzas, quesadillas, sándwiches panini, quiché y otros. Rebane con un movimiento enfrente y hacia atrás para cortar los alimentos.

Servidor:

Para usar el servidor simplemente tenga el borde de la espátula separado de usted y con un movimiento de pala levante la pizza y colóquela en un plato de servir.



Uso y Cuidados:

Lave la Pinza, el Forro de Silicón, el Servidor y la tabla para cortar de Bambú a mano con agua y jabón suave. No deberán ser limpiados con ningún material corrosivo. Antes de usarse o guardarse deben estar completamente secos.

Las orillas de la espátula y el cortador pueden ser filosos. Siempre corte separado de usted. **PRECAUCIÓN**, las orillas con dientes pueden ser filosas, no utilice orillas con dientes para ayudarse.



¡ Una pizza perfecta siempre!



INTRODUCCIÓN

Bienvenido al Manual y Recetario del NuWave. Este libro contiene el Manual completo con instrucciones e imágenes para ayudarle a familiarizarse con su Horno NuWave; también se incluye nuestro Recetario, el cual está lleno de grandiosas recetas fáciles de preparar y consejos adicionales que le ayudarán a preparar deliciosas comidas gourmet en la mitad de tiempo de lo que le tomaría cocinando en un horno convencional.

Cocinar es fácil y rápido con el Horno NuWave® Pro Infrared de Hearthware Home Products®. Este versátil electrodoméstico combina el infrarrojo y el calor de conducción y convección para ahorrar tiempo, energía e incluso calorías.

El NuWave no requiere de precalentar o descongelar: Sólo coloque la comida congelada en el horno y presione los botones para programar el tiempo y Nivel de Potencia. Para su mayor comodidad el horno utiliza un sistema de cocción por capas, el cual permite cocinar diferentes alimentos al mismo tiempo sin mezclar sabores.

El Horno NuWave® Pro Infrared es también una saludable opción. No se requiere de aceite o grasa para cocinar carnes o aves en él y su diseño único drena de dos a tres veces más la cantidad de grasa que un horno convencional. Y como los vegetales son cocinados más rápido retienen los nutrientes esenciales que se consumirían cocinando en la estufa.

Visite www.nuwaveoven.net para accesorios y partes, además de consejos y más recetas compartidas por usuarios alrededor de todo el mundo!

Nuestra misión es exceder las expectativas de nuestros clientes proporcionando productos nuevos e innovadores que utilicen la tecnología más avanzada que exista hoy. Visite nuestro sitio www.hearthware.com para ver otros productos hechos para usted por los creadores del NuWave.

Esperemos que usted disfrute el usar su Horno NuWave® Pro Infrared.

	Altura de la Parrilla	Fresca	Congelada	Temperatura Interna de el Termometro
Res/Cordero:				
Trozo (½ pulgada de grueso)	4 pulg	4-5 c/lado	6-7 c/lado	150°F (65°C)
Trozo (1 pulgada de grueso)	4 pulg	6 c/lado	11 c/lado	150°F (65°C)
Bistec (1 pulgada de grueso)	4 pulg	5-6 c/lado 6-7 c/lado 7-8 c/lado 9-10 c/lado	11 c/lado 13 c/lado 14 c/lado 18 c/lado	Poco Cocido 135°-140°F (60°C) T. Medio 140°-150°F (66°C) Cocido 150°-160°F (71°C) Bien Cocido 160°-170°F (77°C)
Bistec (2 pulgada de grueso)	4 pulg	7 c/lado 9 c/lado 10 c/lado 12 c/lado	15-17 c/lado 17-19 c/lado 20-22 c/lado 23-25 c/lado	Poco Cocido 135°-140°F (60°C) T. Medio 140°-150°F (66°C) Cocido 150°-160°F (71°C) Bien Cocido 160°-170°F (77°C)
Asado 3-5 lb. Deje reposar 10 min. antes de servir	1 pulg	15 min/lb. 18 min/lb. 20 min/lb. 23 min/lb.	25 min/lb. 28 min/lb. 30 min/lb. 33 min/lb.	Poco Cocido 120°-129°F (54°C) T. Medio 130°-139°F (60°C) Cocido 140°-149°F (65°C) Bien Cocido 150°-159°F (71°C)
Puerco:				
Tocino	4 pulg	8 min.		Para más crujiente volteé y cocine por 2 minutos adicionales.
Jamón	1 pulg	15 min/lb.		Agregué el glaseado antes de los últimos 5 minutos de cocción.
Salchicas	4 pulg	4 c/lado	5 c/lado	
Trozo	4 pulg	5 c/lado	7 c/lado	165°F (74°C)
Italiano	4 pulg	5 c/lado	8 c/lado	165°F (74°C)
Chuleta	4 pulg	5 c/lado	10-12 c/lado	160°-170°F (71°-77°C)
Asada 3-7 lb.	1 pulg	20-25 min/lb.	30 min/lb.	160°-170°F (71°-77°C)
Lomo, Pequeno	4 pulg	10-12 c/lado	20 c/lado	160°-170°F (71°-77°C)
Costilla al gusto	Cualquiera	15 c/lado	25 c/lado	160°-170°F (71°-77°C)
Costilla Estilo Country	4 pulg	13 c/lado	20 c/lado	160°-170°F (71°-77°C)
Hot Dogs	4 pulg	6 c/lado	10 c/lado	150°F (65°C)
Pollo:				
Piezas: (Pachugas, piernas, muslos)	4 pulg	10 c/lado	13 c/lado	170°F (76°C)
Completo	1 pulg	15 min/lb.	23-25 min/lb.	180°F (82°C)
Pechuga sin hueso y piel	4 pulg	7-8 c/lado	10 c/lado	170°F (76°C)
Huevos:				
Hervidos	1 pulg	8-11 lado	Terminar de Cocinar, enfriar con agua fría, pelar, servir.	
Pavo:				
Completo 8-10 lb.	1 pulg	15-17 min/lb.	20-22 min/lb.	180°F (82°C)
Pechuga 5-7 lb.	1 pulg	12 min/lb.	15 min/lb.	180°F (82°C)
Piernas	1 pulg	23 c/lado	30 c/lado	180°F (82°C)
Alas	1 pulg	15 c/lado	23 c/lado	180°F (82°C)

	Altura de la Parrilla	Fresca	Congelada	Temperatura Interna de el Termometro
Poultry:				
Godomiz (1-1½ lb)	1 pulg	15-20 min/lb.	30-35 min/lb.	170°-180°F (77°-82°C)
Pato (Completo 5-6 lb)	1 pulg	12 min/lb.	24 min/lb.	170°-180°F (77°-82°C)
Mariscos:				
Pescado: Filetes (½ pulgada de grueso)	4 pulg	3-4 c/lado	5-7 c/lado	150°F (65°C)
Pescado: Filetes (1 pulgada de grueso)	4 pulg	4-5 c/lado	7-9 c/lado	150°F (65°C)
Pescado completo (3-4 pulgada grueso)	4 pulg	15 c/lado	25 c/lado	150°F (65°C)
Carmarenas Tamaño Mediano 2½	4 pulg	3-4 c/lado	4-6 c/lado	El tiempo de cocinar puede variar de acuerdo al tamaño.
Callos de Hacha de mar	4 pulg	4 c/lado	5 c/lado	La langosta y callos se cambian de color opaco cuando se termina de cocinar.
Callos de Hacha de muelle	4 pulg	3 c/lado	3-4 c/lado	
Cola de Langosta (4 onzas)	4 pulg	4 c/lado	6 c/lado	Poner la langosta en una cacerola con agua y hervir por 2 min. antes de meter en el horno.
Langosta entera	4 pulg	13-16 min/lb.		
Verduras / Frutas:				
Elote	Cualquiera	5 c/lado		También puede sazonar al gusto y envolver en papel aluminio como otra opción.
Verduras crudas	Cualquiera	20-30 min.		Cortar en cuadritos de 2 pulgada y untar el aceite. 8 onzas cada uno.
Papas, Enteras	Cualquiera	45-47 min.		
Mitad o a lo largo	Cualquiera	30 min.		
A la francesa	Cualquiera	20 min.		
Cebollas Asadas	4 pulg	20 min.		Cortar y quitar ½ pulg, de arriba y untar aceite.
Ajos Asados	4 pulg	25 min.		Varía de acuerdo a lo grueso.
Espárragos Asados	4 pulg	5-8 min.		Cortar a la mitad, quitar cáscara y semillas, colocar en un plato, untar aceite.
Calabaza	Cualquiera	30-35 min.		
Berenjena Entera	Cualquiera	30 min.		
Berenjena, rebanada (½ pulg)	4 pulg	12-15 min.		
Manzanas Horneadas	Cualquiera	18-20 min.		Quitar corazón.
Peras Horneadas	Cualquiera	20-25 min.		Cortar a la mitad, quitar corazón.
Pizza / Quesadillas:				
			Congelada	
Pan Delgada	4 pulg	15-18 min. (+)		
Pan Regular	4 pulg	18-20 min. (+)		
Pan Grueso	4 pulg	20-25 min. (+)		
Quesadilla	4 pulg	4 c/lado		
1) Coloque la pizza en el sartén de silicon en su nuwave oven. 2) Horne la maza por tiempo indicado o a su gusto. 3) Bolteé la pizza con el queso bocariba y remueva el sartén de silicon. 4) Horne la pizza 3-5 munitos más o asta su preferencia.				

CONSEJOS PARA SU HORNO NUWAVE

Hemos proporcionado recetas fáciles de preparar además de consejos útiles para obtener resultados perfectos siempre. Busque los siguientes iconos junto a las recetas para consejos adicionales, recetas saludables para el corazón y/o recetas para ahorrar aún más tiempo.



Recetas para ahorrar aún más tiempo, su tiempo de preparación será aún menor.



Estas recetas son saludables para el corazón.



Consejos para utilizar su Horno NuWave Pro Infrared.

Tocino: Cocine por 8-9 minutos en la rejilla de 4". Para un crujiente extra, voltéelo y cocine por otros 2 minutos. Espolvoree azúcar morena para un sabor dulce. Para una limpieza más fácil coloque papel aluminio en la cacerola y, una vez que la grasa se seque, retire el aluminio.

Huevos Herridos sin necesidad de agua: Coloque los huevos en la parilla de 1" y cocínelos en Nivel de Potencia No. 9 por 10 minutos. Saque los huevos pronto dejándolos enfriar por completo por 5 minutos. Páselos por agua fría o colóquelos en un tazón con agua fría para poder quitarles el cascarón fácilmente.

Para cocinar una pizza congelada coloque un trozo de papel pergamino debajo de ella, luego ponga la pizza BOCA ABAJO sobre el papel y cocine según las instrucciones. Para terminar, voltee la pizza y cocine por otros 3-5 minutos hasta que el queso se derrita.

Para cocinar pizza en el Horno NuWave Pro Infrared fácilmente, use la Pinza para Pizza para voltearla y quedará de Amoré!

Para asar o cocer al vapor: Coloque las verduras directamente debajo de la cabeza de potencia del Horno NuWave Pro Infrared para asarlas. Para cocer al vapor, coloque los vegetales envueltos en un trozo de papel aluminio, rocíelos con un poco de agua para que circule el vapor. Si los desea además con un toque asado, quite el aluminio en los últimos dos minutos del tiempo de cocción.

Para unas succulentas espinacas al vapor, colóquelas dentro de papel aluminio con 1 oz. de mantequilla, sal y pimienta, agregue un poquito de agua. Selle las orillas. Coloque en la rejilla de 1" y cocine a potencia alta (HI) por 10 minutos o hasta que queden tiernas.

Cubra la comida con papel aluminio para evitar que se dore de más. El calor circulará de todas maneras, pero podrá hacerse más lento el tiempo de cocción.

Para facilitar la limpieza del horno coloque papel aluminio en la cacerola y, una vez que la grasa se seque, retírelo y sacuda los residuos.

Recuerde, los rayos infrarrojos no penetrarán el aluminio. El calor circulará de todas maneras, pero podrá hacerse más lento el tiempo de cocción.

Consejos para Res, Aves, Cerdo y Mariscos: Siempre voltee la carne de res cuando vaya a la mitad del tiempo de cocción para que se dore mejor.

Para usar su sazónador favorito en carnes congeladas, rocíe un poco de agua y luego agregue el sazónador, esto permitirá que se pegue en la carne.

Unte sazónadores en la carne fresca para que el sazónador se hornee bien dentro de la carne.

Para ahorrar tiempo, marine la carne en una bolsa sellada o un contenedor y congele en porciones separadas. Utilice la tabla de cocción para considerar los tiempos correctos para carnes congeladas.

Utilizar un termómetro para carnes es esencial para revisar la temperatura interna de la carne. Nuestra tabla de cocción proporciona las temperaturas seguras para todo tipo de carne.

Consejo para Pavo: Comience cocinando el pavo con la pechuga boca abajo la primera mitad del tiempo. Cuando lo voltee, deberá estar lo suficientemente descongelado para sacar la menudencia. En los últimos 20-30 minutos rellene la cavidad con su relleno favorito y termine decocinar. *cada libra en el Nivel de Potencia 8.* Para cocinar un Jamón: El Horno NuWave® Pro Infrared puede cocinar un jamón de hasta 8 lb. sin hueso y uno de hasta 14 lb. con la Hornilla Extensora. Coloque el jamón en la rejilla de 1". Para mejores resultados voltee el jamón a la mitad del tiempo de cocción. Agregue salsa durante los últimos 5 minutos de cocción. Bañe el jamón con el jugo de la cacerola. Si se dora demasiado rápido, coloque papel aluminio encima. Cocine 15 minutos por cada libra en el Nivel de Potencia 8.

Las galletas pueden ser horneadas en la cacerola y puede usar la rejilla para enfriarlas. Coloque de 10 a 12 galletas en la cacerola dependiendo del tamaño. Hornee a potencia alta (HI) por 9-12 minutos. Quite el domo y deje reposar las galletas en la cacerola por dos minutos. Póngalas en la rejilla para que se terminen de enfriar.

Para los país de costra, hornee sólo la costra por sólo 15-20 minutos. Agregue el relleno y cocine el resto del tiempo como se indique.

Para mejores resultados en panes y postres reduzca el Nivel de Potencia a 8. Coloque el platillo en la rejilla de 1". Siga las instrucciones originales en lugar de reducir el tiempo en un 20%.

Para deshidratar fruta o carne coloque rebanadas muy delgadas de fruta o carne ($\frac{1}{8}$ "- $\frac{1}{4}$ " de grosor) en las rejillas. Asegúrese de esparcirlas bien para un mejor flujo de aire. Cocine en Nivel de Potencia 2 ó 3.

- Cada vez que el ciclo de cocción se complete, inmediatamente reseteé el tiempo hasta que la comida se deshidrate. No deje reposar, pues podría provocar humedad.

- Usted puede programar el tiempo hasta por 10 horas en los modelos digitales. Sin embargo, para prevenir un exceso de humedad no deje el domo colocado en el horno cuando se termine la deshidratación.

- Si se genera demasiada humedad en el Horno NuWave® Pro Infrared levante un poco el domo para dejar escapar el vapor. Así la temperatura bajará y la humedad se saldrá.

Para recalentar sobrantes de comida colóquelos en un plato apto para horno o en papel aluminio. Caliente por 4-5 minutos. Quedarán con un sabor como si estuvieran recién hechos. Si va a recalentar fideos o arroz rocíe un poco de agua en el plato y cúbralo con papel aluminio para prevenir que se sequen. Asegure el papel aluminio a las orillas de la rejilla o extiéndalo hasta afuera del horno para prevenir que produzca viento en el Horno NuWave® Pro Infrared durante el proceso de cocción.

Huevos con Chorizo

- 2 huevos grandes
- 3 onzas de chorizo
- 2 cucharadas de salsa
- 2 onzas de queso monterrey jack rayado
- salsa picante al gusto

Comprima el chorizo en las orillas de un plato. Rompa los huevos al centro y añada la salsa y el queso en la parte de arriba. Coloque el plato en la rejilla de 1" y cocine a nivel alto por 10 minutos o hasta que los huevos estén listos.

(1 porción)

Cangrejo Fundido

- 2 tazas de cangrejo cocido (atún o camarón)
- ¼ taza de mayonesa
- ½ taza de apio picado
- ¼ taza de cebollitas picadas
- 1 cucharadita de jugo de limón
- sal y pimienta al gusto
- 4 rebanadas de pan blanco ligeramente tostadas
- ½ taza de queso monterrey gratinado

Mezcle el cangrejo, la mayonesa, el apio, las cebolletas y el jugo de limón. Agregue sal y pimienta al gusto. Divida la mezcla entre las 4 rebanadas de pan y ponga también el queso encima de cada una de ellas. Coloquelas directamente en la rejilla de 4" y hornee a potencia alta (HI) por 4 minutos o hasta que se calienten bien y el queso se derrita.

(4 porciones)

Elote Estilo Mexicano

- 4 elotes
- ¼ taza de mantequilla derretida
- ¼ taza de mayonesa
- ½ taza de queso cotija rallado o queso fresco
- 4 cuartos de limón (opcional)
- chile en polvo o pimentón dulce al gusto
- sal y pimienta al gusto

Coloque los elotes en la rejilla de 4" y áselos a potencia alta (HI) por 5 minutos de cada lado. Saque los elotes e inmediatamente únteles la mantequilla y la mayonesa. Espolvoree el queso, el chile en polvo, sal y pimienta al gusto. Sirva con trozos de limón.

(2-4 porciones)

Papas a la Parnesana

- 2 papas para hornear grandes
- aceite de oliva al gusto
- sal y pimienta al gusto
- ½ taza de queso parmesano

Corte ½ pulgada a los cuatro extremos de las papas para hacerlas con forma cuadrada. Corte (a lo largo) papas de ½ pulgada y agrégueles aceite de oliva, sal y pimienta. Colóquelas en la rejilla de 4" y hornee a potencia alta (HI) por 20 minutos o hasta que queden crujientes (voltéelas a la mitad del tiempo). Antes de servir las agrégueles el queso parmesano.

(2-4 porciones)



Camarones a la Cerveza

- 1 libra de camarones crudos **
- 4 dientes de ajo machacados
- 1 taza de cerveza
- 1 cucharada de sazónador Old Bay

Coloque todos los ingredientes en un plato para pay y póngalo en la rejilla de 4". Hornee a potencia alta (HI) por 7 minutos.

Congelado: 12 minutos

** El tiempo de cocción puede variar de acuerdo al tamaño de los camarones. Camarones grandes: pelados y limpios. Sívalos calientes o fríos. Camarones pequeños para pelarse y comerse: Sin pelar, sívalos frescos.

(4 porciones)

Albóndigas

- 1 libra de carne molida
- 1 taza de crutones
- ½ taza de salsa de spaghetti preparada
- 2 dientes de ajo picados
- ½ cebolla amarilla mediana, picada
- 1 cucharada de hierbas italianas secas
- 2 huevos grandes
- ¼ taza de queso parmesano rayado

Mezcle todos los ingredientes y forma bolitas de 2". Colóquelas en la rejilla de 4" y hornee a potencia alta (HI) por 10-12 minutos (volteándolas si lo desea).

(6-8 porciones)



Cena Mexicana 💡

- 1 onzas de arrachera, pollo o cerdo
- 1 cebolla española grande
- 1 pimiento verde
- 1 pimiento rojo
- 1 pimiento amarillo
- sal y pimienta al gusto
- 1 paquete de sazónador mezclado para tacos o fajitas
- 8 onzas de queso mexicano o cheddar rayado
- 1 paquete de tortillas salsa de su elección

Corte todos los vegetales y la carne en tiras de 3" x ¼". Espolvoree la carne con el sazónador. Coloque en la rejilla de 4" los vegetales alrededor y la carne al centro, puede encimarlos un poco. Hornee a potencia alta (HI) por 8 minutos. Quite el domo y voltee las verduras y la carne. Coloque las tortillas debajo en la cacerola bien envueltas en papel aluminio. Hornee nuevamente a potencia alta (HI) por otros 8 minutos o hasta que la carne esté lista. Con cuidado abra el papel aluminio y coloque las verduras y la carne en las tortillas calientes, agregue queso y salsa. Enróllelas y disfrute.

Alternativa: Las Quesadillas se pueden preparar de forma similar: Coloque la tortilla en papel aluminio y ponga encima los ingredientes de la receta que más le gusten. Ponga otra tortilla encima y cierre el papel aluminio. Coloque en la cacerola o en la rejilla de 1" o 2" y hornee a potencia alta (HI) por 8 minutos. Si desea preparar más al mismo tiempo, vaya cambiando paquetes de tortillas en los diferentes niveles durante el tiempo de cocción.

(2 porciones)

Pollo al Romero ❤️💡

- 4 cucharadas de romero
- 4 cabezas grandes de ajo, molidas
- 4 cucharadas de mantequilla
- un pollo de 3 libras
- sal y pimienta al gusto

Afloje el pellejo utilizando un palillo chino o una espátula de plástico, introduciéndola entre la piel y la carne. Mezcle el romero, el ajo y la mantequilla hasta que se derrita. Vierta la mezcla de mantequilla debajo del pellejo y de masaje a todo el pollo. Colóquelo, con la pechuga boca abajo, en la rejilla de 1" y cocine a nivel alto por 20 minutos. Después voltee y bañe con el jugo, colóquelo en la cacerola y cocine por otros 25 minutos.

Alternativa: Para derretir mantequilla en el NuWave colóquela en un recipiente apto para hornear y póngalo en la cacerola o en la rejilla de 1". Hornee a potencia alta (HI) por alrededor de 3-4 minutos.

(4-6 porciones)

Pechuga de Pollo a la Mantequilla ❤️

- 4-6 onzas de pechuga
- 2 cucharadas de mantequilla
- 4 cucharaditas de perejil picado
- sal y pimienta al gusto

Coloque el pollo en un plato ovalado no profundo y agregue los otros ingredientes. Coloque el plato en la rejilla de 4" y cocine a nivel alto por 8 minutos.

(1 porción)

Pollo al Limón

- 4 pechugas o muslos de pollo
- jugo de un limón
- 1 taza de vermouth seco o vino blanco
- sazónador de pimienta limón
- sal y pimienta al gusto
- 1 cucharada de maizena

Coloque el pollo en un recipiente de tamaño adecuado sobre la rejilla de 4". Agregue el vino y el jugo de limón sobre él. Espolvoree con el sazónador. Hornee a potencia alta (HI) por 35 minutos volteándolo una vez. Para hacer la salsa ponga los jugos en un tazón y revuelva con la maizena. Caliente por 1-2 minutos o hasta que espese.

(4 porciones)

Muslos de Pollo Fritos

- 4 muslos grandes u 8 pequeños
- 1/3 taza de leche descremada
- 1/2 taza de pan rallado
- 2-4 cucharadas de margarina

Sumerja cada muslo en la leche y luego páselo por el pan. Colóquelos expandidos en una cacerola engrasada y rocíe con mantequilla. Coloque la cacerola en la rejilla de 1" y hornee a potencia alta (HI) por 15 minutos. Voltee el pollo y cocine por otros 15 minutos o hasta que el jugo se seque.

(4 porciones)

Camarones con Limón ❤️

- 12 camarones grandes, pelados y limpios
- jugo de medio limón
- 2 cucharadas de aceite de oliva
- 1 cucharadita de pimienta-limón

Coloque todo en un tazón y póngalo en la rejilla de 4". Cocine a nivel alto por 6 minutos, revuelva levemente.

(2 porciones)

Enchiladas de Pechuga de Pavo ❤️

- 4.4 onzas de chuletas de pechuga de pavo
- 4 rebanadas de queso mozzarella o queso blanco
- mexicano, alrededor de 4 onzas
- sazónador estilo mexicano al gusto
- 1/2 taza de salsa preparada
- 1/2 taza de crema agria
- cilantro picado

Aplane las chuletas hasta alcanzar un grosor de 3/8" y coloque sobre ellas el queso y el sazónador. Enróllelas y colóquelas, con la abertura hacia abajo, alrededor de la orilla de un plato para pay. Rocíe con aceite de cocina, coloque en la rejilla de 4" y cocine a nivel alto por 10 minutos. Mientras tanto, caliente la salsa por un minuto. Vierta la salsa sobre el pavo y espolvoree el cilantro.

(4 porciones)

Cerdo en Mole ❤️

- 1 chuleta de cerdo de 4-6 onzas
- 2 cucharadas de mole
- 2 cucharadas de semillas de ajonjolí

Puede encontrar el mole en tiendas de comida mexicana, éste da un succulento e interesante sabor a la carne de cerdo y a las recetas de pollo. Extienda el mole sobre la superficie de la chuleta y espolvoree el ajonjolí. Colóquela en la rejilla de 4" y cocine a nivel alto por 5 minutos, voltee y cocine por otros 5 minutos.

(1 porción)



Pizza Mexicana

- 1 (8-9") tortilla de harina
- 2 cucharadas de salsa de tomate
- ½ cucharadita de sazónador de tacos o mezcla de especias mexicana
- jalapeños rebanados al gusto
- ⅓ taza de cebolletas picadas
- ½ taza de queso cheddar rayado

Coloque la tortilla en la rejilla de 4". Mezcle la salsa con las especias y viértala sobre la parte superior de la tortilla. Coloque los jalapeños y las cebolletas al gusto sobre la salsa y al final ponga el queso encima. Cocine a potencia alta (HI) por 10 minutos.

(1 porción)

Calzones

- 1 tubo de masa refrigerada para pizza
- 1 taza de queso mozzarella o monterey jack rayado
- ½ taza de salsa preparada para spaghetti
- salchichas, pepperoni, brócoli, cebollas guisadas u otro ingrediente de su elección

Extienda la masa y corte discos de 2, 6". Rocíe con aceite 2 trozos cuadrados de papel aluminio de 10". Coloque los discos de masa en el aluminio y ponga cantidades iguales de ingredientes en ellos, dóblelos a la mitad para formar un medio círculo y pliegue las orillas. Envuélvalos con el papel aluminio y colóquelos en la rejilla de 1". Cocine a potencia alta (HI) por 20 minutos o hasta que estén crujientes y dorados.

(2-4 porciones)

Carnitas ♥

- 2 (4 onzas) de chuletas de cerdo o bistec de paleta
- 1 cucharadita de orégano en polvo
- 1 cucharadita de sal de ajo
- 1 cucharadita de comino en polvo

Unte las chuletas con las especias y colóquelas dentro de un plato no profundo en la rejilla de 4". Cocine a nivel alto por 15 minutos. Pase la carne a una tabla de cortar y macháquela con un mazo hasta que queden como tiritas. Regrese la carne al plato y cocine por otros 8 minutos.

(2 porciones)

Helado de Piña Caramelizado

- 4 rebanadas de piña fresca sin hueso (de 1" de grosor)
- ½ taza de azúcar morena
- ½ cucharadita de canela
- 2 cucharadas de crema espesa
- 4 bolas de helado de vainilla o de yogurt de vainilla
- 1 taza de salsa de caramelo tibia

Coloque la piña en la rejilla de 4". Espolvoree cada rebanada con azúcar y canela. Ponga un poco de crema sobre ellas. Cocine a potencia alta (HI) por 4 ó 5 minutos o hasta que el azúcar burbujee y se dore. Coloque las rebanadas en platos para servir y póngales encima el helado y la salsa de caramelo.

(4 porciones)



Manzana Crujiente

- 4 manzanas peladas, sin hueso y rebanadas a un grosor de ⅛"
- ½ taza de harina
- ½ taza de azúcar morena
- ½ taza de avena instantánea
- ¼ taza de mantequilla suavizada
- ¼ taza de azúcar granulada
- ¾ cucharadita de canela

Engrase un recipiente redondo para pastel de 9" y coloque en él las rebanadas de manzana. En un tazón mediano ponga la harina, el azúcar morena, la avena y la mantequilla y mezcle bien. Por otro lado, en otro plato pequeño mezcle el azúcar granulada y la canela y espolvoreelas sobre las manzanas. Coloque la mezcla de avena encima. Ponga el recipiente en la rejilla de 1" y hornee a nivel alto (HI) por 40 minutos o hasta que las manzanas queden suaves y el jugo esté burbujeante.

(8 porciones)



Tacos de Salmón Cubierto con Chile Ancho 🌶️

- 24 onzas de filete de salmón
- 1 cucharada de aceite canola
- 1 cucharadita de chile ancho en polvo
- 1 cucharada de comino
- 2 cucharadas de azúcar morena
- 1 cucharadita de salsa de soya
- 6 onzas de col rayada
- ½ taza de aderezo ranch con jalapeño
- 8 a 12 tortillas de maíz

Enjuague los filetes de salmón y séquelos con una toalla de papel. Cepíllelos con el aceite por ambos lados. Coloque los filetes sobre papel pergamino en la rejilla de 4" con la piel hacia arriba. Cocine por 5 minutos a potencia alta (HI). Mientras tanto, revuelva el chile en polvo con el comino y el azúcar. Voltee el salmón cuando pasen los 5 minutos y agregue la salsa de soya encima. Rocíe encima la mezcla de azúcar y cocine a potencia alta nuevamente hasta el que alcance el cocimiento que se desee, alrededor de 8 ó 10 minutos más. Mientras el salmón se cocina, mezcle la col con el aderezo. Caliente las tortillas envueltas en papel aluminio colocándolas en la parte de abajo del horno en los últimos 5 minutos de cocinado del salmón. Sirva el salmón con las tortillas y la mezcla de col.

(4 porciones)

